

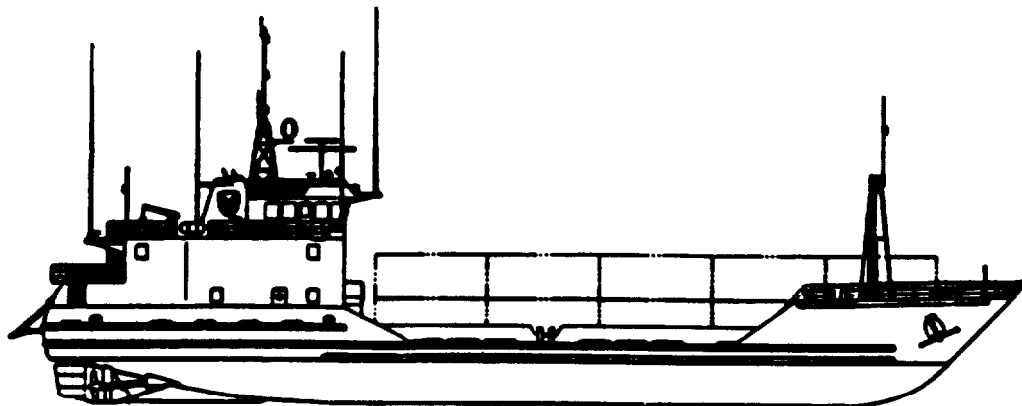
TECHNICAL MANUAL

UNIT, INTERMEDIATE DIRECT  
SUPPORT  
AND INTERMEDIATE GENERAL  
SUPPORT  
MAINTENANCE INSTRUCTIONS

LANDING CRAFT, UTILITY  
(LCU)

NSN 1905-01-154-1191

BASIC CRAFT  
(PART I)



INTRODUCTION	1-1
UNIT MAINTENANCE INSTRUCTIONS	2-1
INTERMEDIATE DIRECT SUPPORT MAINTENANCE INSTRUCTIONS	3-1
INTERMEDIATE GENERAL SUPPORT MAINTENANCE INSTRUCTIONS	4-1
APPENDIXES	A-1
ALPHABETICAL INDEX	INDEX 1
POWER DISTRIBUTION FOLDOUTS	FP-1

*Distribution Statement A: Approved for public release; distribution is unlimited*



CHANGE  
NO. 5

HEADQUARTERS  
DEPARTMENT OF THE ARMY  
WASHINGTON, D.C., 08 February 2008

**Technical Manual**  
**UNIT, INTERMEDIATE DIRECT SUPPORT AND**  
**INTERMEDIATE GENERAL SUPPORT**  
**MAINTENANCE INSTRUCTIONS**

**LANDING CRAFT, UTILITY (LCU)**  
**BASIC CRAFT (PART 1)**  
**NSN 1905-01-154-1191**

**DISTRIBUTION STATEMENT A:** Approved for public release, distribution is unlimited.

TM 55-1905-223-24-18-1, 17 January 1989, is changed as follows:

1. Remove and insert pages as indicated below. New or changed text material is indicated by a vertical bar in the margin. An illustration change is indicated by a miniature pointing hand.

Remove pages	Insert pages
A and B	A through D
i and ii	i and ii
1-1 and 1-2	1-1 and 1-2
1-5 and 1-6	1-5 and 1-6
1-13 and 1-14	1-13 and 1-14
1-19 through 1-22	1-19 through 1-22
1-27 through 1-30	1-27 through 1-30
1-41 and 1-42	1-41 and 1-42
1-47 and 1-48	1-47 and 1-48
1-51 and 1-52	1-51 and 1-52
1-61 through 1-66	1-61 through 1-64
....	(1-65 blank)/1-66
2-1 through 2-8	2-1 through 2-8
2-105 and 2-106	2-105 and 2-106
2-111 through 2-114	2-111 through 2-114
2-129 and 2-130	2-129 and 2-130
2-205 through 2-222	2-205/(2-206 blank)
2-223 and 2-224	(2-223 blank)/2-224
2-227 and 2-228	2-227 and 2-228
2-281 and 2-282	2-281 and 2-282
2-415 through 2-418	2-415 through 2-418
2-441 and 2-442	2-441 and 2-442
2-731 through 2-734	2-731 through 2-734
2-743 and 2-744	2-743 and 2-744
2-747 and 2-748	2-747 and 2-748
2-763 through 2-790	2-763 through 2-782
....	2-783/(2-784 blank)
....	2-785 through 2-790

Remove pages

2-793 and 2-794  
2-813 and 2-814  
2-821 and 2-822  
2-825 and 2-826  
.....  
2-1013 through 2-1018  
2028's


Insert pages

2-793 and 2-794  
2-813 and 2-814  
2-821 and 2-822  
2-825 and 2-826  
2-952.1 through 2-952.3/(2-952.4 blank)  
2-1013 through 2-1018  
2028's

2. Retain this sheet in front of manual for reference purposes.

By Order of the Secretary of the Army:

Official:

  
JOYCE E. MORROW  
Administrative Assistant to the  
Secretary of the Army  
0801605

GEORGE W. CASEY, JR.  
General, United States Army  
Chief of Staff

**DISTRIBUTION:**

To be distributed in accordance with IDN 254813, requirements for TM 55-1905-223-24-18-1.

**CHANGE  
No. 4**

**HEADQUARTERS  
DEPARTMENT OF THE ARMY  
WASHINGTON, D.C., 15 MAY 2002**

Unit, Intermediate Direct Support and Intermediate General Support  
Maintenance Instructions

**LANDING CRAFT, UTILITY (LCU)  
BASIC CRAFT (PART 1)  
NSN 1905-01-154-1191**

Approved for public release; Distribution is unlimited.

TM 55-1905-223-24-18-1, 17 January 1989 is changed as follows:

1. Remove and insert pages as indicated below. New or changed text material is indicated by a vertical bar in the margin. An illustration change is indicated by a miniature pointing hand.

Remove page

-----

i and ii

2-95 and 2-96

Insert page

A and B

i and ii

2-95 and 2-96

2. Retain this sheet in front of manual for reference purposes.

**By Order of the Secretary of the Army**

Official:

  
JOEL B. HUDSON

*Administrative Assistant to the  
Secretary of the Army*

0201509

ERIC K. SHINSEKI  
*General, United States Army  
Chief of Staff*

**DISTRIBUTION:**

**To be distributed in accordance with IDN 254813, requirements for TM 55-1905-223-24-18-1**



CHANGE

No. 3

HEADQUARTERS  
DEPARTMENT OF THE ARMY  
WASHINGTON, D.C., 9 NOVEMBER 1992

Unit, Intermediate Direct Support and Intermediate General Support  
Maintenance Instructions

**LANDING CRAFT, UTILITY (LCU)  
BASIC CRAFT (PART I)  
NSN 1905-01-154-1191**

Approved for public release; Distribution is unlimited

TM 55-1905-223-24-18-1,17 January 1989 is changed as follows:

1. Remove and insert pages as indicated below. New or changed text material is indicated by a vertical bar in the margin. An illustration change is indicated by a miniature pointing hand.

Remove pages

2-85 and 2-86  
2-981 and 2-982

Insert pages

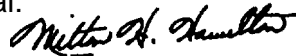
2-85and2-86  
2-981 and 2-982

2. Retain this sheet in front of manual for reference purposes.

**By Order of the Secretary of the Army:**

GORDON R. SULLIVAN  
*General, United States Army*  
*Chief of Staff*

Official:



MILTON H. HAMILTON  
*Administrative Assistant to the*  
*Secretary of the Army*  
03022

**DISTRIBUTION:**

To be distributed in accordance with DA Form 12-25-E, block no. 4813, requirements for  
TM 55-1905-223-18-1.





**CHANGE**  
**NO. 2**

HEADQUARTERS  
DEPARTMENT OF THE ARMY  
WASHINGTON, D.C., 22 May 1991

Unit, Intermediate Direct Support, and Intermediate General Support  
Maintenance Instructions

**LANDING CRAFT, UTILITY (LCU)**  
**BASIC CRAFT (PART I)**  
**NSN 1905-01-154-1191**

Approved for public release; distribution is unlimited

TM 55-1905-223-24-18-1, 17 January 1989 is changed as follows:

1. Remove and insert pages as indicated below. New or changed text material is indicated by a vertical bar in the margin. An illustration change is indicated by a miniature pointing hand.

Remove pages

2-447 and 2-448

- - - - -

Insert pages

2-447 and 2-448

2-448.1 and 2-448.2

2. Retain this sheet in front of manual for reference purposes.

**By Order of the Secretary of the Army:**

**CARL E. VUONO**  
*General, United States Army*  
*Chief of Staff*

**Official:**

**THOMAS F. SIKORA**  
*Brigadier General, United States Army*  
*The Adjutant General*

**DISTRIBUTION:**

To be distributed in accordance with DA Form 12-25E, (qty rqr block no. 4813).



CHANGE }  
NO. 1 }

HEADQUARTERS  
DEPARTMENT OF THE ARMY  
WASHINGTON, D.C., 30 July 1990

**Unit, Intermediate Direct Support,  
and Intermediate General Support  
Maintenance Instructions**

**LANDING CRAFT, UTILITY  
(LCU) BASIC CRAFT (PART 1)  
NSN 1905-01-154-1191**

**Approved for public release; distribution is unlimited.**

**TM 55-1905-223-24-18-1, 17 January 1989, is changed as follows:**

1. Remove and insert pages as indicated below. New or changed text material is indicated by a vertical bar in the margin. An illustration change is indicated by a miniature pointing hand.

Remove pages

2-201 and 2-202  
2-231 and 2-232  
2-245 through 2-248  
2-251 and 2-252  
2-255 and 2-256  
2-265 and 2-266  
2-269 through 2-276  
2-279 through 2-282  
2-287 through 2-294  
2-299 and 2-300  
2-309 and 2-310  
2-321 and 2-322  
2-327 through 2-330  
2-335 and 2-336  
2-341 through 2-348  
2-351 through 2-360  
2-365 and 2-366  
2-385 and 2-386  
2-395 and 2-396  
2-399 and 2-400  
2-409 through 2-412  
2-415 and 2-416  
2-419 and 2-420  
2-423 and 2-424  
2-427 through 2-430  
2-433 and 2-434  
2-437 and 2-438  
2-443 through 2-452  
2-501 and 2-502  
2-507 through 2-510  
2-513 through 2-518  
2-521 through 2-540  
2-545 through 2-552  
2-555 and 2-556  
2-559 and 2-560

Insert pages

2-201 and 2-202  
2-231 and 2-232  
2-245 through 2-248  
2-251 and 2-252  
2-255 and 2-256  
2-265 and 2-266  
2-269 through 2-276  
2-279 through 2-282  
2-287 through 2-294  
2-299 and 2-300  
2-309 and 2-310  
2-321 and 2-322  
2-327 through 2-330  
2-335 and 2-336  
2-341 through 2-348  
2-351 through 2-360  
2-365 and 2-366  
2-385 and 2-386  
2-395 and 2-396  
2-399 and 2-400  
2-409 through 2-412  
2-415 and 2-416  
2-419 and 2-420  
2-423 and 2-424  
2-427 through 2-430  
2-433 and 2-434  
2-437 and 2-438  
2-443 through 2-452  
2-501 and 2-502  
2-507 through 2-510  
2-513 through 2-518  
2-521 through 2-540  
2-545 through 2-552  
2-555 and 2-556  
2-559 and 2-560

Remove pages

2-563 and 2-564  
2-567 and 2-568  
2-573 through 2-578  
2-581 and 2-582  
2-593 and 2-594  
2-597 and 2-598  
2-603 through 2-612  
2-619 through 2-624  
2-629 and 2-630  
2-637 through 2-640  
2-643 through 2-670  
2-673 and 2-674  
2-679 and 2-680  
2-685 and 2-686  
2-691 and 2-692  
2-697 and 2-698  
2-703 and 2-704  
2-709 and 2-710  
2-715 and 2-716  
2-727 and 2-728  
2-733 and 2-734  
2-741 through 2-744  
2-747 and 2-748  
2-757 through 2-760  
2-763 through 2-772  
2-775 through 2-796  
2-807 through 2-818  
2-821 and 2-822  
2-827 through 2-830  
2-833 through 2-858  
2-861 and 2-862  
2-867 and 2-868  
2-873 and 2-874  
2-877 and 2-878  
2-881 through 2-884  
2-887 through 2-892  
2-895 and 2-896  
2-899 through 2-902  
2-905 and 2-906  
2-925 and 2-926  
2-933 and 2-934  
2-937 and 2-938  
2-953 and 2-954  
2-981 and 2-982

Insert pages

2-563 and 2-564  
2-567 and 2-568  
2-573 through 2-578  
2-581 and 2-582  
2-593 and 2-594  
2-597 and 2-598  
2-603 through 2-612  
2-619 through 2-624  
2-629 and 2-630  
2-637 through 2-640  
2-643 through 2-670  
2-673 and 2-674  
2-679 and 2-680  
2-685 and 2-686  
2-691 and 2-692  
2-697 and 2-698  
2-703 and 2-704  
2-709 and 2-710  
2-715 and 2-716  
2-727 and 2-728  
2-733 and 2-734  
2-741 through 2-744  
2-747 and 2-748  
2-757 through 2-760  
2-763 through 2-772  
2-775 through 2-796  
2-807 through 2-818  
2-821 and 2-822  
2-827 through 2-830  
2-833 through 2-858  
2-861 and 2-862  
2-867 and 2-868  
2-873 and 2-874  
2-877 and 2-878  
2-881 through 2-884  
2-887 through 2-892  
2-895 and 2-896  
2-899 through 2-902  
2-905 and 2-906  
2-925 and 2-926  
2-933 and 2-934  
2-937 and 2-938  
2-953 and 2-954  
2-981 and 2-982

2. Retain this sheet in front of manual for reference purposes.

By Order of the Secretary of the Army:

**CARL E. VUONO**  
*General, United States Army*  
*Chief of Staff*

Official:

**WILLIAM J. MEEHAN, II**  
*Brigadier General, United States Army*  
*The Adjutant General*

**DISTRIBUTION:**

To be distributed in accordance with DA Form 12-25A, Direct Support and General Support Maintenance requirements for Landing Craft, Utility, LUC-1466, Type III.



**INSERT LATEST CHANGED PAGES. DESTROY SUPERSEDED DATA.**

**LIST OF EFFECTIVE PAGES**

**NOTE:** The portion of text affected by the changes is indicated by a vertical line in the outer margins of the page. Changes to illustrations are indicated by miniature pointing hands. Changes to wiring diagrams are indicated by shaded areas.

Dates of issue for original and changed pages are:

Original	0	17 January 1989	Change	3	09 November 1992
Change	1	30 July 1990	Change	4	15 May 2002
Change	2	22 May 1991	Change	5	08 February 2008

**TOTAL NUMBER OF PAGES IS 1142 CONSISTING OF THE FOLLOWING:**

Page No.	*Change No.	Page No.	*Change No.
Cover.....	3	2-205/(2-206 blank).....	5
a/(blank).....	0	2-207 through 2-222 Deleted.....	5
Introduction/(blank).....	0	(2-223 blank)/2-224.....	5
i.....	5	2-225 and 2-226.....	0
ii.....	0	2-227.....	5
1-1.....	5	2-228 through 2-230.....	0
1-2 through 1-5.....	0	2-231.....	1
1-6.....	5	2-232 through 2-244.....	0
1-7 through 1-12.....	0	2-245.....	1
1-13 and 1-14.....	5	2-246 and 2-247.....	0
1-15 through 1-19.....	0	2-248.....	1
1-20 and 1-21.....	5	2-249 and 2-250.....	0
1-22 through 1-27.....	0	2-251.....	1
1-28 and 1-29.....	5	2-252 through 2-254.....	0
1-30 through 1-41.....	0	2-255.....	1
1-42.....	5	2-256 through 2-265.....	0
1-43 through 1-46.....	0	2-266.....	1
1-47.....	5	2-267 through 2-269.....	0
1-48 through 1-50.....	0	2-270.....	1
1-51.....	5	2-271.....	0
1-52 through 1-61.....	0	2-272.....	1
1-62 through 1-66.....	5	2-273.....	0
2-1.....	0	2-274.....	1
2-2 and 2-3.....	5	2-275.....	0
2-4.....	0	2-276.....	1
2-5 through 2-8.....	5	2-277 and 2-278.....	0
2-9 through 2-85.....	0	2-279.....	1
2-86.....	3	2-280.....	0
2-87 through 2-94.....	0	2-281.....	5
2-95.....	4	2-282 through 2-286.....	0
2-96 through 2-104.....	0	2-287.....	1
2-105 and 2-106.....	5	2-288.....	0
2-107 through 2-111.....	0	2-289.....	1
2-112 and 2-113.....	5	2-290.....	0
2-114 through 2-128.....	0	2-291.....	1
2-129.....	5	2-292 and 2-293.....	0
2-130 through 2-201.....	0	2-294.....	1
2-202.....	1	2-295 through 2-298.....	0
2-203 and 2-204.....	0	2-299.....	1

\* Zero in this column indicates an original page.

Page No.	*Change No.	Page No.	*Change No.
2-300 through 2-309.....	0	2-449 .....	1
2-310 .....	1	2-450 .....	0
2-311 through 2-321.....	0	2-451 .....	1
2-322 .....	1	2-452 through 2-500.....	0
2-323 through 2-326.....	0	2-501 and 2-502.....	1
2-327 .....	1	2-503 through 2-506.....	0
2-328 .....	0	2-507 .....	1
2-329 .....	1	2-508 .....	0
2-330 through 2-335.....	0	2-509 .....	1
2-336 .....	1	2-510 through 2-512.....	0
2-337 through 2-340.....	0	2-513 .....	1
2-341 and 2-342.....	1	2-514 and 2-515.....	0
2-343 .....	0	2-516 .....	1
2-344 .....	1	2-517 .....	0
2-345 .....	0	2-518 .....	1
2-346 .....	1	2-519 and 2-520.....	0
2-347 .....	0	2-521 .....	1
2-348 .....	1	2-522 .....	0
2-349 through 2-351.....	0	2-523 .....	1
2-352 .....	1	2-524 and 2-525.....	0
2-353 .....	0	2-526 .....	1
2-354 through 2-360.....	1	2-527 .....	0
2-361 through 2-365.....	0	2-528 .....	1
2-366 .....	1	2-529 .....	0
2-367 through 2-384.....	0	2-530 .....	1
2-385 .....	1	2-531 .....	0
2-386 through 2-395.....	0	2-532 .....	1
2-396 .....	1	2-533 .....	0
2-397 and 2-398.....	0	2-534 .....	1
2-399 .....	1	2-535 .....	0
2-400 through 2-408.....	0	2-536 .....	1
2-409 .....	1	2-537 .....	0
2-410 and 2-411.....	0	2-538 and 2-539.....	1
2-412 .....	1	2-540 through 2-544.....	0
2-413 through 2-415.....	0	2-545 .....	1
2-416 through 2-418.....	5	2-546 .....	0
2-419 .....	0	2-547 .....	1
2-420 .....	1	2-548 .....	0
2-421 and 2-422.....	0	2-549 through 2-551.....	1
2-423 .....	1	2-552 through 2-555.....	0
2-424 through 2-426.....	0	2-556 .....	1
2-427 .....	1	2-557 and 2-558.....	0
2-428 and 2-429.....	0	2-559 .....	1
2-430 .....	1	2-560 through 2-562.....	0
2-431 through 2-433.....	0	2-563 .....	1
2-434 .....	1	2-564 through 2-566.....	0
2-435 through 2-437.....	0	2-567 .....	1
2-438 .....	1	2-568 through 2-572.....	0
2-439 through 2-441.....	0	2-573 .....	1
2-442 .....	5	2-574 and 2-575.....	0
2-443 .....	1	2-576 and 2-577.....	1
2-444 .....	0	2-578 through 2-581.....	0
2-445 through 2-447.....	1	2-582 .....	1
2-448 .....	2	2-583 through 2-592.....	0
2-448.1 and 2-448.2.....	2	2-593 and 2-594.....	1

\* Zero in this column indicates an original page.



Page No.	*Change No.	Page No.	*Change No.
2-595 through 2-597	0	2-758 and 2-759	0
2-598	1	2-760	1
2-599 through 2-602	0	2-761 and 2-762	0
2-603	1	2-763 and 2-764	1
2-604	0	2-765 and 2-766	5
2-605 and 2-606	1	2-767 through 2-769	1
2-607	0	2-770	5
2-608 through 2-612	1	2-771	0
2-613 through 2-619	0	2-772 through 2-774	5
2-620 through 2-623	1	2-775 through 2-778	1
2-624 through 2-628	0	2-779 through 2-782	5
2-629	1	2-783/(2-784 blank)	5
2-630 through 2-636	0	2-785 through 2-788	1
2-637 through 2-639	1	2-789	5
2-640 through 2-643	0	2-790 and 2-791	0
2-644 through 2-650	1	2-792 through 2-794	1
2-651	0	2-795	0
2-652 through 2-654	1	2-796	1
2-655	0	2-797 through 2-806	0
2-656 and 2-657	1	2-807 and 2-808	1
2-658	0	2-809	0
2-659	1	2-810	1
2-660 and 2-661	0	2-811	0
2-662 through 2-669	1	2-812 through 2-818	1
2-670 through 2-673	0	2-819 and 2-820	0
2-674	1	2-821	1
2-675 through 2-679	0	2-822 through 2-826	0
2-680	1	2-827 through 2-830	1
2-681 through 2-685	0	2-831 and 2-832	0
2-686	1	2-833 through 2-857	1
2-687 through 2-690	0	2-858 and 2-860	0
2-691	1	2-861	1
2-692 through 2-696	0	2-862 through 2-866	0
2-697	1	2-867	1
2-698 through 2-702	0	2-868 through 2-873	0
2-703	1	2-874	1
2-704 through 2-708	0	2-875 through 2-877	0
2-709	1	2-878	1
2-710 through 2-714	0	2-879 and 2-880	0
2-715	1	2-881	1
2-716 through 2-726	0	2-882 and 2-883	0
2-727	1	2-884	1
2-728 through 2-730	0	2-885 and 2-886	0
2-731 through 2-733	5	2-887	1
2-734	1	2-888 and 2-889	0
2-735 through 2-740	0	2-890	1
2-741	1	2-891	0
2-742	0	2-892	1
2-743	5	2-893 and 2-894	0
2-744	1	2-895	1
2-745 and 2-746	0	2-896 through 2-898	0
2-747	5	2-897 and 2-898	0
2-748 through 2-756	0	2-899	1
2-757	1	2-900 and 2-901	0

\* Zero in this column indicates an original page.

TM 55-1905-223-24-18-1

Page No.	*Change No.	Page No.	*Change No.
2-902 .....	1	2-952.1 and 2-952.2 .....	5
2-903 and 2-904 .....	0	2-952.3/(2-952.4 blank) .....	5
2-905 .....	1	2-953 .....	1
2-906 through 2-924 .....	0	2-954 through 2-980 .....	0
2-925 .....	1	2-981 .....	3
2-926 through 2-932 .....	0	2-982 through 2-1013 .....	0
2-933 .....	1	2-1014 through 2-1018 .....	5
2-934 through 2-936 .....	0	2-1019 through 2-1074 .....	0
2-937 .....	1		
2-938 through 2-952 .....	0		

\* Zero in this column indicates an original page.

**WARNING**

**MODIFICATION HAZARD**

Unauthorized modifications, alterations or installations of or to this equipment are prohibited and are in violation of AR 750-10. Any such unauthorized modifications, alterations or installations could result in death, injury or damage to the equipment.

**HIGH PRESSURE HYDRAULIC SYSTEM HAZARDS**

Hydraulic systems can cause serious injuries if high pressure lines or equipment fail. Never work on hydraulic systems or equipment unless there is another person nearby who is familiar with the operation and hazards of the equipment, and who can give first aid. A second person should stand by controls to turn off hydraulic pumps in an emergency.

**MOVING MACHINERY HAZARDS**

Be very careful when operating or working near moving machinery. Running engines, rotating shafts, and other moving machinery parts could cause personal injury or death.

**ELECTRICAL HAZARDS**

Do not be misled by the term "low voltage." Potentials as low as 50 volts may cause death under adverse conditions. Be careful not to contact 115-Vac input connections when installing operating equipment. Whenever the nature of the operation permits, keep one hand away from the equipment to reduce the hazard of current flowing through the body.

**FLAMMABLE LIQUID AND COMBUSTIBLE VAPOR HAZARDS**

Gasoline, fuel oil, lubricating oil, grease, paint, paint thinner, cleaning solvents and other combustible liquids present a serious fire hazard. Always store combustible liquids in approved containers and in their designated compartments or deck storage locations. Ensure exhaust and ventilation fans are operating while using cleaning solvents or paint products. Never store or charge batteries in a confined space without ventilation or near operating electrical equipment.

When refueling and defueling the vessel, ensure appropriate signs are posted in visible locations and warnings are announced over the vessel's public address system. Smoking, welding and any operation which involves open flames must be prohibited throughout the vessel.

**CAUSTIC AND CORROSIVE CHEMICAL HAZARDS**

Battery acid and water purification chemicals such as bromine and chlorine can cause serious burns to eyes or exposed areas of skin. Always wear eye protection and protective clothing when working with caustic and corrosive chemicals. If chemicals accidentally contact skin or eyes, immediately flush with large quantities of water and seek medical attention.

**COMPRESSED AIR HAZARDS**

High pressure compressed air tanks, piping systems and air operated devices possess potential for serious injury to eyes and exposed areas of skin due to escaping air pressure.

**ELECTROMAGNETIC RADIATION HAZARDS**

Electromagnetic radiation from the searchlight, radar, and radio antennas has the potential for serious radiation burns. Do not stand in the path of radiation emission.

**FIRE SUPPRESSANT HAZARDS**

Fire suppressant chemicals displace oxygen and can cause suffocation. Immediately evacuate areas where they will be used.

**For Artificial Respiration, refer to FM 21-11.**



## INTRODUCTION

This manual is divided into two volumes:

Volume 1, TM 55-1905-223-24-18-1 consists of Chapters 1 and 2.

Volume 2 TM 55-1905-223-14-18-2 consists of Chapters 3 and 4, Appendixes A through D, Glossary and Index.



**UNIT, INTERMEDIATE DIRECT SUPPORT  
AND INTERMEDIATE GENERAL SUPPORT  
MAINTENANCE INSTRUCTIONS  
FOR THE  
LANDING CRAFT, UTILITY (LCU) BASIC CRAFT (PART 1)  
NSN 1905-01-154-1191**

**REPORTING ERRORS AND RECOMMENDING IMPROVEMENTS**

You can help improve this publication. If you find any mistakes or if you know of a way to improve the procedures, please let us know. Submit your DA Form 2028 (Recommended Changes to Equipment Technical Publications) through the Internet, on the Army Electronic Product Support (AEPS) website. The Internet address is <https://aeprs.ria.army.mil>. The DA Form 2028 is located under the Public Applications section in the AEPS Public Home Page. Fill out the form and click on SUBMIT. Using this form on the AEPS will enable us to respond quicker to your comments and better manage the DA Form 2028 program. You may also mail, fax or e-mail your letter or DA Form 2028 direct to: TACOM Life Cycle Management Command, ATTN: AMSTA-LC-LMPP / TECH PUBS, 1 Rock Island Arsenal, Rock Island, IL 61299-7630. The e-mail address is [ROCK-TACOM-TECH-PUBS@conus.army.mil](mailto:ROCK-TACOM-TECH-PUBS@conus.army.mil). The fax number is DSN 793-0726 or Commercial (309) 782-0726.

**DISTRIBUTION STATEMENT A:** Approved for public release; distribution is unlimited.

TABLE OF CONTENTS

	PAGE
PART I	
CHAPTER 1 INTRODUCTION.....	1-1
Section I General Information .....	1-1
Section II Equipment Data .....	1-2
Section III Principles of Operation.....	1-3
CHAPTER 2 UNIT MAINTENANCE INSTRUCTIONS.....	2-1
Section I Repair Parts, Special Tools; Test, Measurement, and Diagnostic Equipment (TMDE); and Support Equipment .....	2-1
Section II Service Upon Receipt .....	2-1
Section III Unit Preventive Maintenance Checks and Services (PMCS) .....	2-4
Section IV Unit Maintenance Troubleshooting .....	2-96
Section V Unit Maintenance Procedures.....	2-183
Section VI Preparation for Storage or Shipment .....	2-1074
PART II	
CHAPTER 3 INTERMEDIATE DIRECT SUPPORT MAINTENANCE INSTRUCTIONS .....	3-1
Section I Repair Parts, Special Tools; Test, Measurement and Diagnostic Equipment (TMDE); and Support Equipment .....	3-1
Section II Service Upon Receipt .....	3-1

TABLE OF CONTENTS - cont

	PAGE
Section III Intermediate Direct Support Preventive Maintenance Checks and Services (PMCS).....	3-2
Section IV Intermediate Direct Support Troubleshooting .....	3-20
Section V Intermediate Direct Support Maintenance Procedures .....	3-43
Section VI Preparation for Storage or Shipment .....	3-753
 CHAPTER 4 INTERMEDIATE GENERAL SUPPORT MAINTENANCE INSTRUCTIONS .....	 4-1
Section I Repair Parts, Special Tools; Test, Measurement, and Diagnostic Equipment (TMDE); and Support Equipment.....	4-1
Section II Service Upon Receipt .....	4-1
Section III Intermediate General Support Preventive Maintenance Checks and Services (PMCS) .....	4-2
Section IV Intermediate General Support Troubleshooting Procedures .....	4-2
Section V Intermediate General Support Maintenance Procedures.....	4-4
Section VI Preparation for Storage or Shipment .....	4-62
 APPENDIX A REFERENCES.....	 A-1
APPENDIX B MAINTENANCE ALLOCATION CHART.....	B-1
APPENDIX C EXPENDABLE/DURABLE SUPPLIES AND MATERIALS LIST.....	C-1
APPENDIX D TORQUE VALUES.....	D-1
GLOSSARY ABBREVIATIONS AND DEFINITIONS.....	Glossary 1
ALPHABETICAL INDEX .....	Index 1
POWER DISTRIBUTION .....	FP - 1



**CHAPTER 1  
INTRODUCTION**

	<u>Page</u>
Section I. General Information.....	1-1
Section II. Equipment Data.....	1-2
Section III. Principles of Operation .....	1-3

**SECTION I. GENERAL INFORMATION**

**1-1. Scope.** The scope of this manual is as follows:

- a. Type of Manual. Unit, Intermediate Direct Support and Intermediate General Support Maintenance manual.
- b. Model Number and Equipment Name. Refer to the individual subsystems of this TM.
- c. Purpose of Equipment. Refer to the individual subsystems of this TM and Operator's Manual TM 55-1905-223-10.

**1-2. Maintenance Forms, Records, and Reports.** Department of the Army forms and procedures used for equipment maintenance are prescribed by DA PAM 738-750, Functional Users Manual for the Army Maintenance Management System (TAMMS).

**1-3. Destruction of Army Materiel.** Refer to TM 750-244-3 for instructions covering the destruction of Army materiel to prevent enemy use.

**1-4. Reporting Equipment Improvement Recommendations (EIR).** If your Landing Craft Utility needs improvement, let us know. Send us an EIR. You, the user, are the only one who can tell us what you don't like about your equipment. Let us know why you don't like the design or performance. If you have Internet access, the easiest and fastest way to report problems or suggestions is to go to <https://aeps.ria.army.mil/aepspublic.cfm> (scroll down and choose to submit an Equipment Improvement Recommendation (EIR), a Product Quality Deficiency Report (PQDR) or a Warranty Claim Action (WCA). You may also submit your information using an SF 368 (Product Quality Deficiency Report). You can send your SF 368 via e-mail, regular mail, or facsimile using the addresses/facsimile numbers specified in DA PAM 738-750, Functional Users Manual for the Army Maintenance Management System (TAMMS). We will send you a reply.

**1-5. Preparation for Storage or Shipment.** Administrative storage of equipment issued to and used by Army activities will have preventive maintenance performed in accordance with the Preventive Maintenance Checks and Services (PMCS) charts before storing. When removing the equipment from administrative storage, the PMCS should be performed to assure operational readiness. Preparation of equipment for shipment or short term storage is covered in paragraph 2-9.

**1-6. Characteristics, Capabilities, and Features.** A very broad view of the Basic Craft Manual (TM 55-1905-223-24-18-1/2) components is covered in the Operator's Manual (TM 55-1905-223-10).

**1-7. Location and Description of Major Components.** Refer to Section II, Equipment Description of Operator's Manual (TM 55-1905-223-10).

## Section II. EQUIPMENT DATA

**1-8. Equipment Data.** Refer to the equipment data given in the Operator's Manual (TM 55-1905-223-10).

**1-9. Safety, Care, and Handling.** Safety precautions must be observed at all times while performing maintenance. General **WARNINGS** and first-aid data appear in the front of this manual. Review all safety information before starting any task. Carefully read through an entire maintenance procedure before performing any maintenance function. Make sure the task can be done safely. All **WARNINGS**, **CAUTIONS**, and **NOTES** are of great importance to your safety and the safety of the equipment.

### Section III. PRINCIPLES OF OPERATION

1-10. General. The following paragraphs provide principles of operation of the LCU systems.

1-11. Power Generation System. The power generation system provides the LCU with primary (240 Vac, 3-phase, 60Hz, 250kW) and emergency (240 Vac, 3-phase, 60Hz, 40kW) electrical power (FIGURE 1-1). Primary power is generated by one of two ship's service diesel generator (SSDG) sets, which supply the main switchboard and the emergency switchboard through a bus tie from the main switchboard. Emergency power is generated by an emergency diesel generator set, which supplies the emergency switchboard for continued operation of vital systems and equipment during loss of primary power. In port, the LCU is capable of receiving shore power (480/240 Vac) through a shore power cable terminating at a two-connection shore power box. If available shore power is 480 Vac, the power is selected at the main switchboard through a circuit breaker and stepped down to 240 Vac by three shore power transformers, prior to main switchboard entry. Shore power of 240 Vac is selected at the main switchboard by circuit breaker, and bypasses the 480 Vac transformers. Automatic bus transfer equipment, located in the emergency switchboard, isolates the emergency switchboard from the main switchboard upon loss of primary power and allows emergency power to be supplied through the emergency switchboard.

a. Ship Service Diesel Generator Engine. Two diesel generator set engines power individual ship service diesel generators, which provide primary electrical power throughout the LCU. The port ship service diesel generator engine (No. 2) is air started; the starboard ship service diesel generator engine (No. 1) is electrically started. Engine control and monitoring are provided from the engine room console and at the individual engine control panel.

b. Shin's Service Generator. Two 250 kW brushless exciter generators provide 240 Vac, three-phase, 60 Hz primary ship's service power. Each generator is capable of providing 110 percent of the necessary at sea load for the propulsion and safety of the ship under normal conditions. The generators may be operated in parallel; however, normal operation has one generator on line and the other in reserve.

c. Main Switchboard. The main switchboard (FIGURE 1-2), located in the engine room operating station, provides generator selection, shore power selection, and power distribution for ship's service 240 Vac and 120 Vac power. Distribution of 120 Vac is accomplished by ship's service 120 Vac transformers located in the engine room operating station. The emergency switchboard bus tie provides 240 Vac to the emergency switchboard. Power selection is provided by closing circuit breakers on the switchboard. Power monitoring is provided by ammeters, voltmeters, frequency meters, and synchronization meters. Controls are provided for manual and automatic generator voltage regulation and generator engine speed regulation. The switchboard bus tie also serves as an emergency 240 Vac power feedback source for the main switchboard from the emergency switchboard, to power selected equipment systems during emergency power conditions. An interlock system is incorporated into the switchboard to prevent shore power from being applied to the switchboard while generator power is applied. The interlock system also prevents the emergency switchboard emergency generator circuit breaker from being closed.

d. Emergency Switchboard. The emergency switchboard (FIGURE 1-3), located in the emergency generator room, normally receives 240 Vac primary power from the main

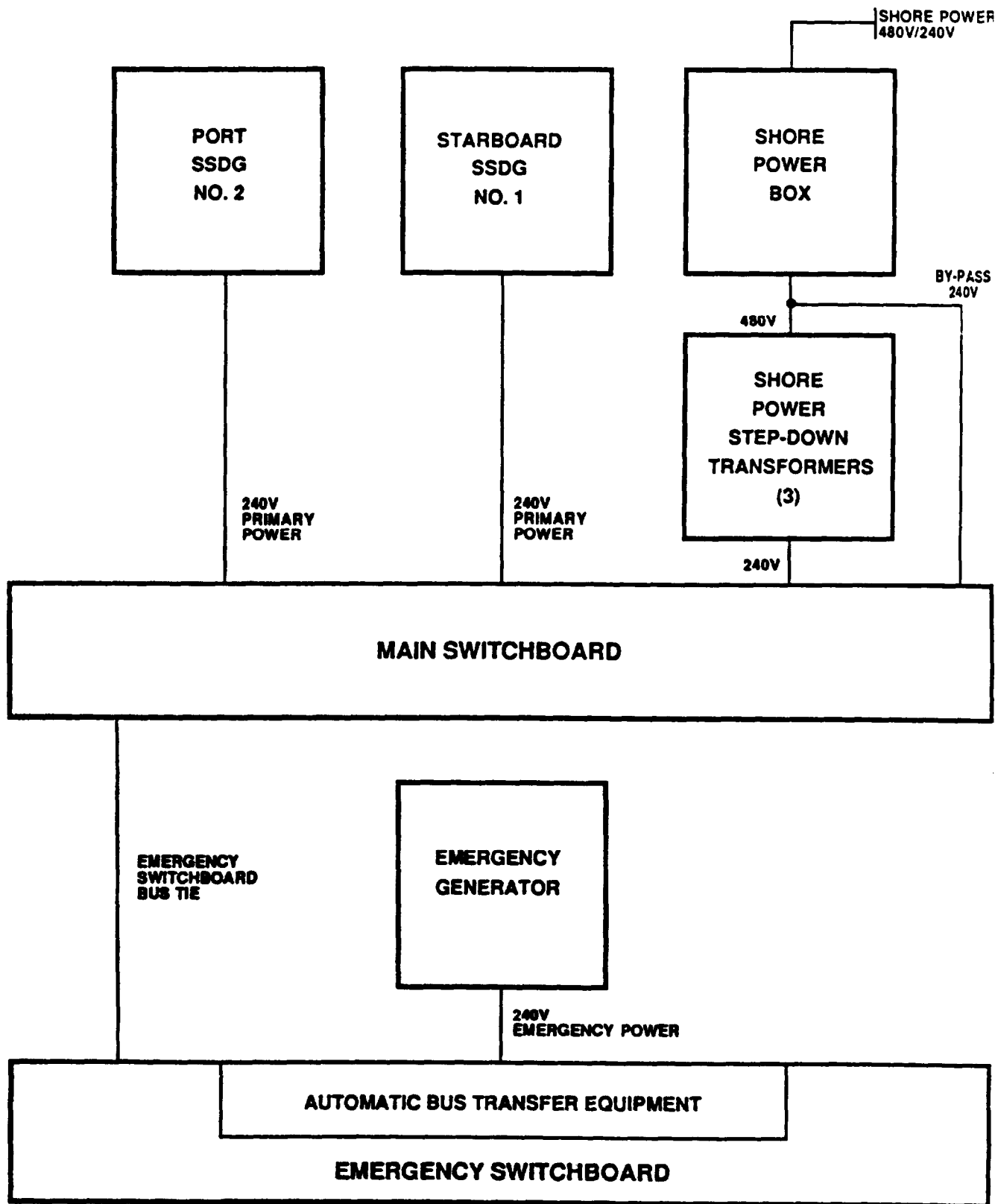


FIGURE 1-1. Power Generation System.

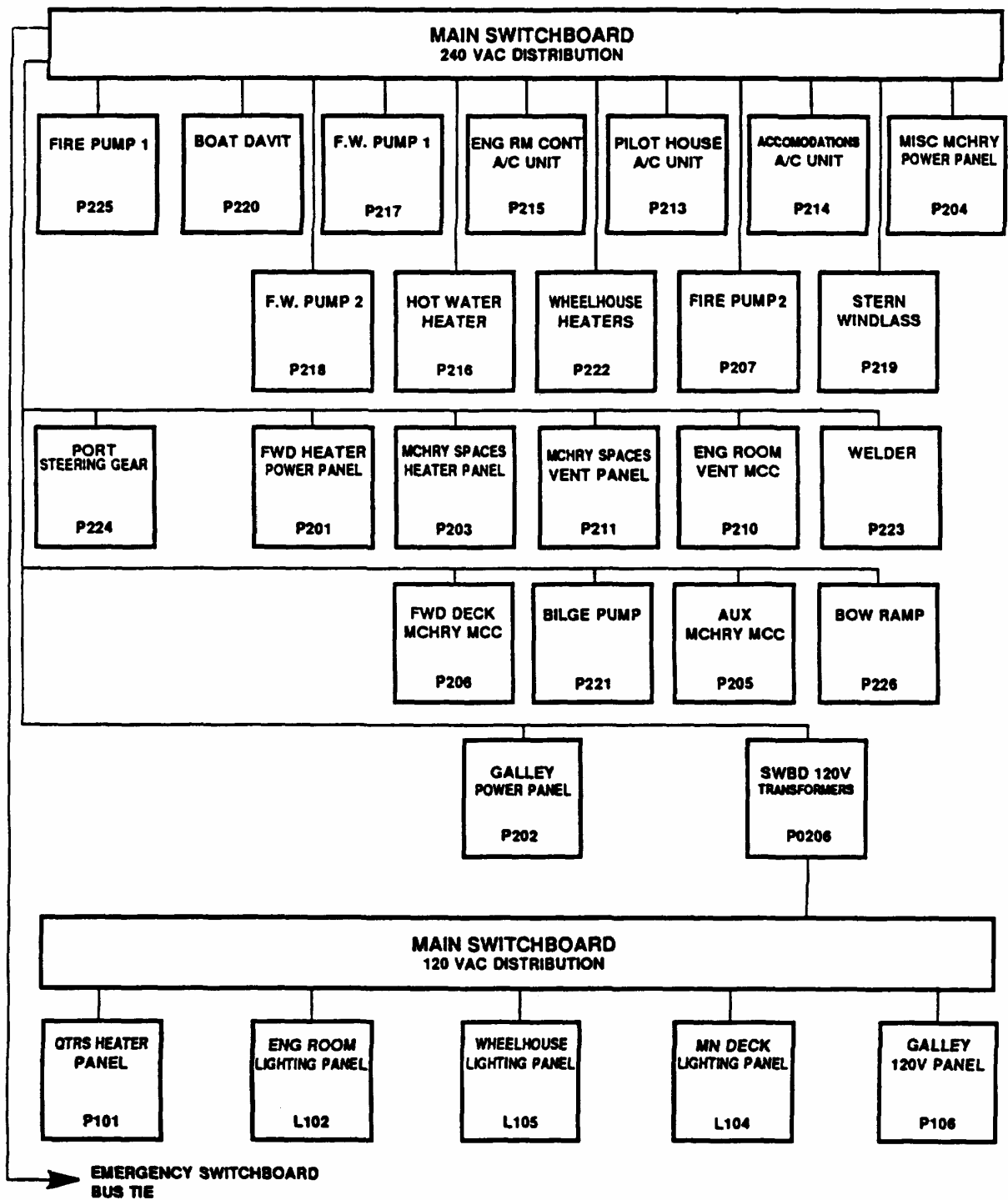


Figure 1-2. Main Switchboard.

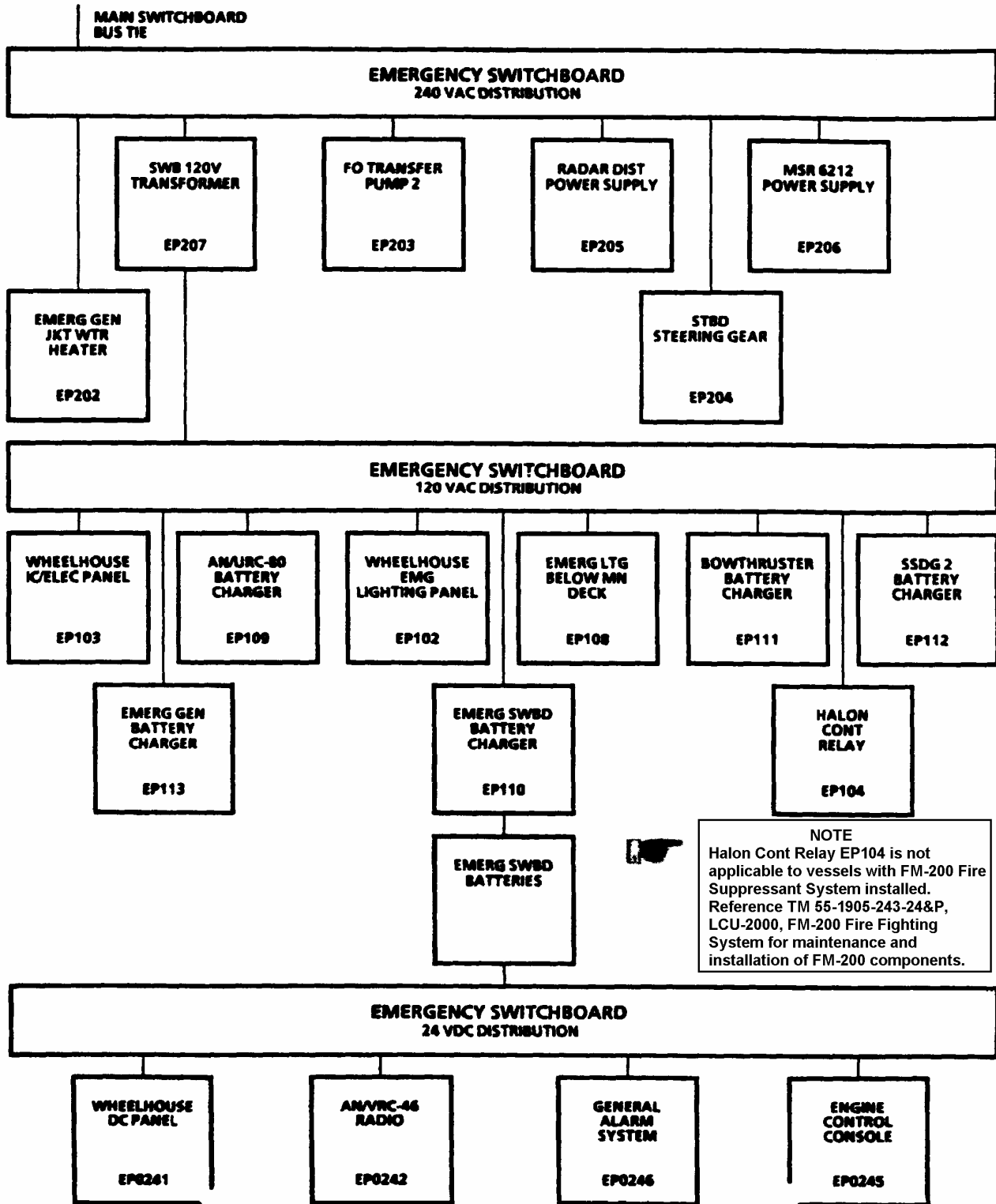


Figure 1-3. Emergency Switchboard.

switchboard through the bus tie. Upon loss of ship's service power from the main switchboard, automatic bus transfer equipment within the emergency switchboard isolates the emergency switchboard and provides for automatic or manual starting of the emergency generator. Power monitoring of the emergency generator is provided by a voltmeter, ammeter, wattmeter, and frequency meter. A voltage adjustment control for the emergency generator output is also provided. A main switchboard bus tie circuit breaker and bus tie bypass switch permit distribution of emergency power (240 Vac) to the main switchboard. The emergency generator circuit breaker is prevented from being closed by an interlock system when primary power is being provided through the bus tie. Power distribution is accomplished through circuit breakers on the switchboard 240 Vac, 120 Vac, and 24 Vdc distribution panels. A step-down transformer provides 120 Vac back to the switchboard, and a 24 Vdc battery charger and switchboard batteries provide 24 Vdc back to the switchboard for distribution.

e. Shore Power Box. The shore power box is located on the 01 level, aft exterior bulkhead. The two-connection shore power box provides a cable connection for shore power and another cable connection for providing shore power to another vessel in tandem.

1-12. Control and Monitoring System. The control and monitoring system provides for the centralization of control and monitoring functions for the main propulsion power train, selected pumps, ship's service diesel generators, and vital alarms. Pilothouse and engine room propulsion control is possible without intervention of engine room personnel. Primary control is from the pilothouse console with one soldier at the engine room console. The system permits constant automatic monitoring of vital machinery operating conditions and initiation of many functions from the engine room console. The control and monitoring system consists of the following: engine room console, pilothouse console, machinery plant monitoring and alarm system, engine order telegraph, steering control panel, dual station throttle control system, bowthruster and auxiliary fire pump control, fire detection, and bow ramp control.

a. Engine Room Console (ERC). The ERC provides a centralized engine room location for: controlling propulsion shafts direction and speed; monitoring machinery alarm conditions; acknowledging engine orders; alerting engineering personnel of assistance needed and acknowledging the dead man alarm notification from the bridge. These functions are provided to the ERC via interfaces with the machinery plant monitoring system, engine order telegraph, and dual station throttle control system.

b. Pilothouse Console (PHC). The PHC provides control and monitoring of the main propulsion power train speed and direction during usual ship operating and maneuvering conditions without intervention of engine room personnel. The PHC also provides for: machinery plant monitoring; autopilot operation; steering system selection and monitoring; bowthruster/auxiliary fire pump engine control; bowthruster control; communicating desired propulsion shaft direction and speed to the ERC; operation of blinker lights; operation of bow ramp; operation of ship's intercommunications system; and activation of ship's general alarm system. These functions are provided to the PHC via interface with the machinery plant monitoring system; autopilot; steering control panel, helm (wheel) and rudder angle indicator; dual station throttle control system, port and starboard main propulsion engine shaft tachometers; bowthruster engine shaft tachometer; bowthruster control panel; engine order telegraph; blinker light key; ship's intercommunications panel; and the general alarm contactor.

c. Dual Station Throttle Control. The dual station throttle control system provides pneumatic direction and throttle control for the main propulsion engines from the PHC and ERC, and the bowthruster/auxiliary fire pump engine from the PHC only.

(1) Main propulsion engine control. The system provides two throttle and direction control valves at both the PHC and the ERC. The ERC contains a pilot air valve for ERC control of the system or transfer of control air to the PHC. The PHC contains a pushbutton air valve for control air at the pilothouse.

(2) Bowthruster/auxiliary fire pump engine control. The PHC contains a throttle control air valve for bowthruster/auxiliary fire pump selection. Selection results in engaging the appropriate power take-off (PTO). The valve also provides throttle control for the engine.

d. Machinery Plant Monitoring System. The machinery plant monitoring system is a microcomputer based system which monitors vital machinery operating conditions. The system consists of the engine room console panel and a color video cathode ray tube (CRT) display on the engine room console and the bridge console panel and color video CRT display located on the pilot house console. The CRT displays date and time, alarm messages, and monitored status. The monitored status is presented in seven pages of displays.

(a) Page 1 - Machinery Plant Control System. Provides a table of contents for the system.

(b) Page 2 - Engine Summary. Displays oil pressure, water temperature, stack temperature, and RPM for both port and starboard main engines.

(c) Page 3 - Engine Summary. Provides oil temperature and oil differential for both port and starboard main engines and also displays left and right main engine bank temperatures for both main engines.

(d) Page 4 - Generator Summary. Displays oil pressure, water temperature, oil temperature, and stack temperature for the port and starboard SSDG engines.

(e) Page 5 - Reduction Gears. Provides oil pressure and oil temperature for the port and starboard reduction gears.

(f) Page 6 - Bowthruster Engine. Displays oil pressure and water temperature for the bowthruster engine.

(g) Page 7 - Fire Pump/Main. Provides indication of valve position for main and emergency system, control air pressure, and start air pressure for the port and starboard main engines and SSDG number 2.

(1) Engine room console panel. The engine room console panel provides a centralized engine room location for starting and stopping the bilge/ballast pump, fresh water makers, fresh water pumps, fire pumps, ship's service diesel generators, and main propulsion engines. Indicator lamps are provided for run condition display of other equipment, control station in operation (PHC or ERC), dead man alarm, and engineers-assistance-needed pushbuttons. The panel also provides controls for the CRT display and audible alarm.



(2) Bridge console panel. The bridge console panel provides controls for main propulsion engines emergency stop, bowthruster/auxiliary fire pump engine start and stop, exhaust and supply ventilator fans shutdown, fire pumps No. 1 and No. 2 start and stop, and dead man alarm illuminated pushbutton. Indicator lamps are provided for port and starboard steering motor running, control station in operation, bowthruster engine running, and fire pumps No. 1 or No. 2 running. The panel also provides controls for operating the panel and CRT display.

e. Engine Order Telegraph (EOT). The EOT communicates desired propeller shaft speed and direction from the pilothouse console to the engine room console when the bridge is not in direct control of the main engines. The system consists of drop-in panels in both the ERC and PHC. The panels contain illuminated pushbuttons and bells. The bells ring at both locations. A two-wire data connection between the panels is used to send and acknowledge orders taken or sent from either panel. Direction is monitored in ahead, astern, and stop position. Wrong direction status is visually and audibly alarmed at both stations. Each panel also alarms for order and power failures.

(1) Power group. The power group consists of two illuminated pushbuttons: PWR ON/LAMP TEST and COMM FAIL/SILENCE. The PWR ON/LAMP TEST pushbutton will apply power to that unit: a power failure of one of the two independent power supplies, fed from Wheel House DC Panel EP024-1, causes the PWR ON/LAMP TEST to flash on and off and the audible alarm to sound. Pushing the pushbutton will silence the alarm, and if one of the power supplies has failed, the PWR ON/LAMP TEST will continue to flash. If both power supplies are available, the lamp will light steady. When a unit is first turned on, or power is restored, the PWR ON/LAMP TEST lamp will flash and the audible alarms will activate. Pushing the pushbutton will silence the alarms and cause the lamp to light steady. The unit then will update itself to the other unit and display any detected faults by alarm or flashing lamps. Communication failure between EOT units will be alarmed by the flashing COMM FAIL/SILENCE illuminated pushbutton and audible alarms. Pushing the pushbutton will silence the audible alarm, and the front panel will display various types of communication failures by indicator lamps. Silencing an alarm within a unit group silences all alarms in that group.

(2) Port and starboard telegraph group. This group consists of ten port and starboard commands (orders): four ahead (AHD) orders, four astern (AST) orders, one BRIDGE CONTROL order, and one STOP order. Completed orders are displayed as steadily illuminated pushbuttons and silenced, audible alarms. A new order can be placed by pushing another pushbutton which then flashes at both stations (pilothouse and engine room consoles). At the same time, the internal horn sounds, and will continue to sound until the new order is acknowledged. The new order is acknowledged at the receiver station by pushing the flashing pushbutton, which then turns to the steady mode. The previous order is then cancelled, and all audible alarms are silenced. New orders can be changed or cancelled at the sending unit prior to acknowledgement by pushing another order pushbutton. When the BRIDGE CONTROL order is acknowledged, the AHD, STOP, and AST pushbutton lamps are turned off. When bridge control is relinquished by placing and acknowledging another order, the BRIDGE CONTROL lamp is turned off, thereby indicating engine room control.

(3) Wrong direction group. This group consists of two indicating lamps (port and starboard shafts) which alarm when a wrong direction condition exists. The wrong direction display and alarm is active after an AHD, STOP, or AST order is acknowledged. If the order has been acknowledged and the shaft direction does not

match the order (AHD-STOP-AST), the wrong direction alarm is activated (WRONG DIRECTION lamp flashes and audible alarm sounds). The flashing WRONG DIRECTION alarm lamp operates immediately but the audible alarm may be delayed to compensate for changing of direction from AHD to AST or AST to AHD. When the correct direction status is achieved, the wrong direction visual and audible alarms are cancelled. If the direction of propulsion thrust changes from the acknowledged EOT direction, then the wrong direction alarm is re-activated.

(4) Standby/finished with engines group. This group consists of three illuminated pushbuttons: STANDBY, CANCEL STANDBY, and FINISHED WITH ENGINES. Together, they function as a separate EOT group similar to the port and starboard EOT groups.

(a) A STANDBY order may be placed independently of any other order.

(b) STANDBY, whether acknowledged or not, may be cancelled by a CANCEL STANDBY order from the initiating EOT.

(c) A receiving EOT must acknowledge a STANDBY order before it can issue a CANCEL STANDBY order.

(d) If the port and/or starboard EOT are active, a FINISHED WITH ENGINES order may be initiated only if both port and starboard EOTs have acknowledged BRIDGE CONTROL or STOP orders.

f. Steering Control Panel. The steering control panel is located on the pilothouse console. The panel provides system power selection, mode of operation including full followup (FFU) using the helm, non-followup (NFU) using pushbutton switches on the panel, and AUTO (autopilot). The panel also contains an alarm panel for each steering gear pumpset, alarm test switch, and cancel switch to silence the alarm. Rudder position commands are input to the steering gear by movement of the helm or pressing pushbutton switches. These input signals operate solenoid activated hydraulic control valves in the pumpset selected. The control valves direct the flow of hydraulic fluid from the pumpset to power cylinders attached to the rudder tiller arms which position the rudder. The steering control panel contains a rudder angle indicator that displays the actual rudder position in degrees. A rudder order indicator below the panel displays a direct indication of the actual position of the helm. The pumpset status panel includes two sets of six indicators which give information on the status of each pumpset system. The green status lamps (POWER AVAILABLE, MOTOR RUN) intensity is adjustable by a DIMMER control. The remainder of the status lamps are activated-by alarm sensors and remain on after the alarm horn has been cancelled, and until the fault is cleared. The NFU pushbutton switches operate relays, which in turn operate the pumpset solenoids until released. The rudder will then remain stationary to the position commanded. When in FFU or AUTO mode, the NFU pushbuttons control the rudder to move in the direction commanded as long as the pushbuttons are depressed. Upon releasing a NFU pushbutton, steering control of the rudder will return to the control mode selected. When in FFU, steering responds to the action of the helm. The rudder will continue to move after the helm is moved to the desired position, until the rudder matches the exact position of the helm as indicated by the rudder order indicator. When in AUTO mode, the course set by the AUTOPILLOT allows hands-off steering of the vessel.

g. Bowthruster Control. The bowthruster control panel located on the pilothouse console provides control and monitoring of the bowthruster waterjet operation. Indicator lamps are provided to indicate that electrical power and hydraulic power are available, minimum hydraulic oil level in the hydraulic oil tank, and minimum lube oil level in the lube oil tank. Alarm horns accompany the visual indication of minimum hydraulic oil and lube oil tank levels. Pushbutton controls are also provided for activating the electrical power unit and hydraulic unit. A toggle switch is used for steering the waterjet nozzle to the angle of thrust desired. The angle of thrust is displayed on a meter.

h. Fire Detection. The fire control panel is located in the aft section of the pilothouse and provides the bridge with status of the vessel fire detection system. The fire control panel is the system main controller processor. It processes all incoming signals from each vessel zone and converts them to an independent output that is displayed on the panel: alarm horn, alarm and status lamps, trouble lamps, battery charger, current and voltage meters. Controls are provided for system reset and lamp testing, alarm silencing, and trouble silencing.

i. Bow Ramp Control. The bow ramp control system consists of three bow ramp control panels: pilothouse console, boatswain storeroom (bow ramp winch), and starboard forecastle deck. Controls are provided for turning the winch electric motor off and on (PHC and boatswain storeroom only) and raising and lowering the ramp. Pushbuttons are provided for starting and stopping the winch hydraulic pump and taking up tension (slack) on the wire rope. Indicator lamps provide visual display of hydraulic oil temperature (above 150°F), tension (slack wire rope), and hydraulic pump running.

j. Dead Man Alarm. The dead man alarm system is incorporated in the machinery plant monitoring engine room console panel and bridge console panel. The bridge console panel contains an illuminated pushbutton that when depressed causes the corresponding illuminated pushbutton and audible horn on the engine room console panel to be activated. If the engine room attendant does not acknowledge the dead man activation by the bridge within a specified time, alarms will sound, signifying the engine room attendant cannot acknowledge. If the engine room attendant answers the dead man alarm within the specified time, both illuminated pushbuttons will extinguish and horn will be silenced.

k. Engineer's Assistance Needed. The engineer's assistance needed system is incorporated in the machinery plant monitoring engine room console panel. The assistance needed system notifies off watch engineers that the ERC attendant needs assistance. The system is activated when the ENGINEER ASSISTANCE NEEDED illuminated pushbutton on the ERC is pushed. This action causes an audible alarm and flashing lamp to be activated at remote panels in the mess room and the chief engineer's stateroom. Pressing the illuminated pushbutton on one of the remote panels will acknowledge the assistance needed request. The system will also be activated by the dead man alarm system if the ERC attendant does not acknowledge the dead man alarm in the specified time limit.

1-13. Fire Detection System. The fire detection system (FIGURE 1-4) sounds an alarm when fire is detected via temperature rate-of-heat rise detectors located throughout the LCD. The system consists of the fire control panel located in the pilothouse, a terminal box, heat rise detectors (thermostats) located in various compartments, manual pull stations, and a 10-inch bell. The heat detectors are arranged in six zones throughout the vessel. When a fire condition is detected,

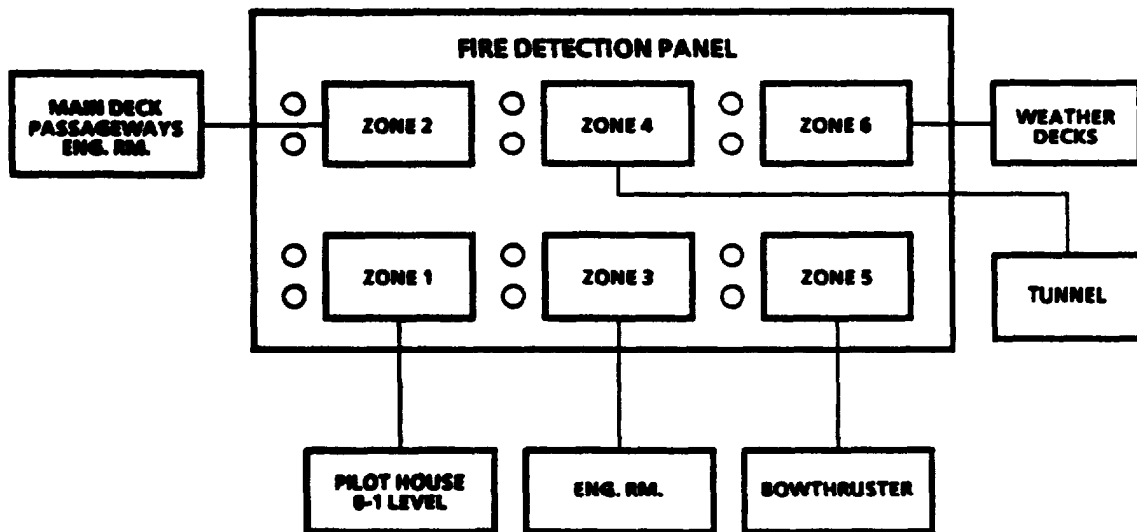


FIGURE 1-4. Fire Detection System.

the associated thermostat sends an alarm signal, via a zone module located in the fire control panel to the fire control panel indicators. When pulled, the manual fire pull box also sends an alarm signal via the zone module to the marine fire detector panel indicators.

**1-14. Main Propulsion System.** The main propulsion system is the power source for the main reduction gear and clutch system which transfers the power to the LCU's propellers. The system consists of two diesel engines. The engines counter-rotate; the port engine rotates counterclockwise, and the starboard engine rotates clockwise. The engines can be operated together or individually.

- a. Engine Instrument and Control Panel. The engine control panel contains indicators which monitor the operation of the engine. Conditions monitored by the control panel are oil temperature, oil pressure, cooling water temperature, oil differential pressure across oil filters, exhaust temperature by bank, starting air pressure, engine RPM (tachometer), and total engine operating hours. These conditions are monitored at the engine room console (ERC) and pilothouse console by the machinery plant monitoring system. The engines can be started and stopped locally at the panel and remotely from the ERC. The engine may be stopped from the PHC, utilizing the main engine emergency trip pushbuttons.
- b. Fuel System. The fuel system which is composed of a fuel pump containing a governor, is driven by the front engine gear train. Filtered fuel is supplied to the injectors via the fuel manifold and cylinder head drillings. Timing is provided by a camshaft through cam rollers and push-tubes to injector rockers which actuate the injectors at the proper time. The governor maintains the speed of the engine at a setting determined by the engine operator. An automatic shutdown feature, which is controlled from the machinery plant monitoring system, will energize a shutdown solenoid, cutting off fuel flow to the engine. This solenoid also contains a plunger for manual shutdown. The fuel system receives fuel oil from the fuel oil transfer piping system.
- c. Air Starting System. The main engine air starting system provides low pressure air to starting motors during engine startup. When energized, a solenoid valve releases air to the starting motor and the motor cranks the engine. The air starting system requires low pressure air from the compressed air piping system.
- d. Lubricating Oil System. The engine is pressure lubricated by a gear-type oil pump mounted to the block and driven by the rear crankshaft gear. The lubricating oil system receives oil from and returns oil to the engine sump. Lubricating oil is supplied to the engine sump from the external lubricating oil tank via the lube oil transfer and dirty oil discharge piping system.
- e. Cooling System. The main engine cooling system provides fresh water cooling to the engines. The cooling system receives fresh water from the fresh water cooling piping system. Fresh water is drawn into the cooling system by centrifugal pumps, pumped through the engine and discharged back to the fresh water cooling piping system. The piping system then routes the heated water through the keel cooler to cool the fresh water before it is pumped back through the engines. The cooling system also contains expansion tanks that handle cooling system overflow, seawater heating for the waste heat evaporator and a convenient point for adding coolant to the system. Two jacket water pumps are used to provide hot jacket water to the evaporators. The jacket water pumps are supplied with power from the auxiliary machinery motor control center P205 and START/STOP pushbuttons adjacent to the evaporators.

**1-15. Commissary Equipment.** Commissary equipment provides for chilled and frozen food storage, food preparation, food service, waste disposal, sanitation, and galley exhaust and fire protection. Chilled and frozen food storage units are freestanding refrigeration units. Food preparation units are freestanding steam kettle, ranges, microwave ovens, fryers, and associated equipment. Food service units include milk dispenser, coffee maker, and soft drink dispensing machine. Waste disposal and sanitation are provided by a garbage disposal, solid waste compactor, and dishwasher. The dishwasher and garbage disposal are connected to the ship's sewage piping system. Galley air exhaust is provided by an exhaust hood tied to ducting and galley exhaust fan which is part of the environmental control system.

**1-16. Laundry Equipment.** Laundry equipment is used by the LCU crew to wash, dry, and maintain uniforms and linen. Laundry equipment consists of an electric automatic washer, electric dryer, ironing board, clothes wringer, double sink, and storage cabinet. The automatic washer and double sink drain to the ship's sewage piping system.

**1-17. Fire Fighting System.** The fire fighting system provides fire stations and specialized chemical fire suppression equipment throughout the vessel. The fire fighting system consists of HALON fire suppression systems, foam proportioners, foam tank, fire stations, fire monitors, fire fighting equipment, and washdown system.

#### NOTE

**Halon 1301 Fire Suppression System is not applicable to vessels with FM-200 Fire Suppressant System installed. Reference TM 55-1905-243-24&P, LCU-2000, FM-200 Fire Fighting System for maintenance and installation of FM-200 components.**

- a. HALON 1301 Fire Suppression System. The HALON system provides fire suppression where highly flammable conditions exist. These areas are the main engine room and paint locker room. The system extinguishes fires in these spaces by totally flooding the space with HALON 1301 agent. The system may be manually actuated by pull cables or pneumatic actuators. Rate-of-rise temperature detectors, when activated, set off an alarm in the pilothouse; however, the detectors do NOT automatically start the HALON system. There is a 60-second delay during which the siren sounds, warning personnel to evacuate the protected area. Pressure switches interconnected with the electrical system of the LCU are activated during the delay for ventilation equipment and lube/fuel oil pump shutdown. Upon discharge, the HALON cylinders will release and flood the designated area in approximately 10 seconds.
- b. Foam Proportioners. The fire fighting system has the capability of inducing aqueous film forming foam (AFFF) into the fire monitors and foam stations. Liquid AFFF is induced into the system via two AFFF three-way proportioners that provide suction to the AFFF tank when water pressure is supplied from either fire pumps No. 1 or 2, auxiliary fire pump, or bilge/ballast pump through system alignment. The system has the capability to discharge sufficient foam to cover the main deck through fire monitors port and starboard (pilot house top), foam station 2 (pilot house top) and foam station 1 (engine room) with 6 inches of foam. This foam proportioning system can be aligned to supply seawater only, by closing the two AFFF tank suction valves.
- c. Fire Stations. Fire stations provide seawater for fire suppression throughout the ship. Fire stations consist of fire plugs connected to the bilge/ballast and fire main piping system. Installed at each fire station is an all-purpose nozzle with 50 feet of hose and a spanner wrench.

d. Fire Monitors. Two fire monitor stations are located on the pilot house top. The monitors provide 360-degree coverage of the main deck. Each monitor has both horizontal and vertical control. These monitors can be aligned to disperse seawater or foam. Piping for the fire monitor supply is routed out of the machinery space via risers to the 02 level (FIGURE 1-5) pilothouse top (port and starboard).

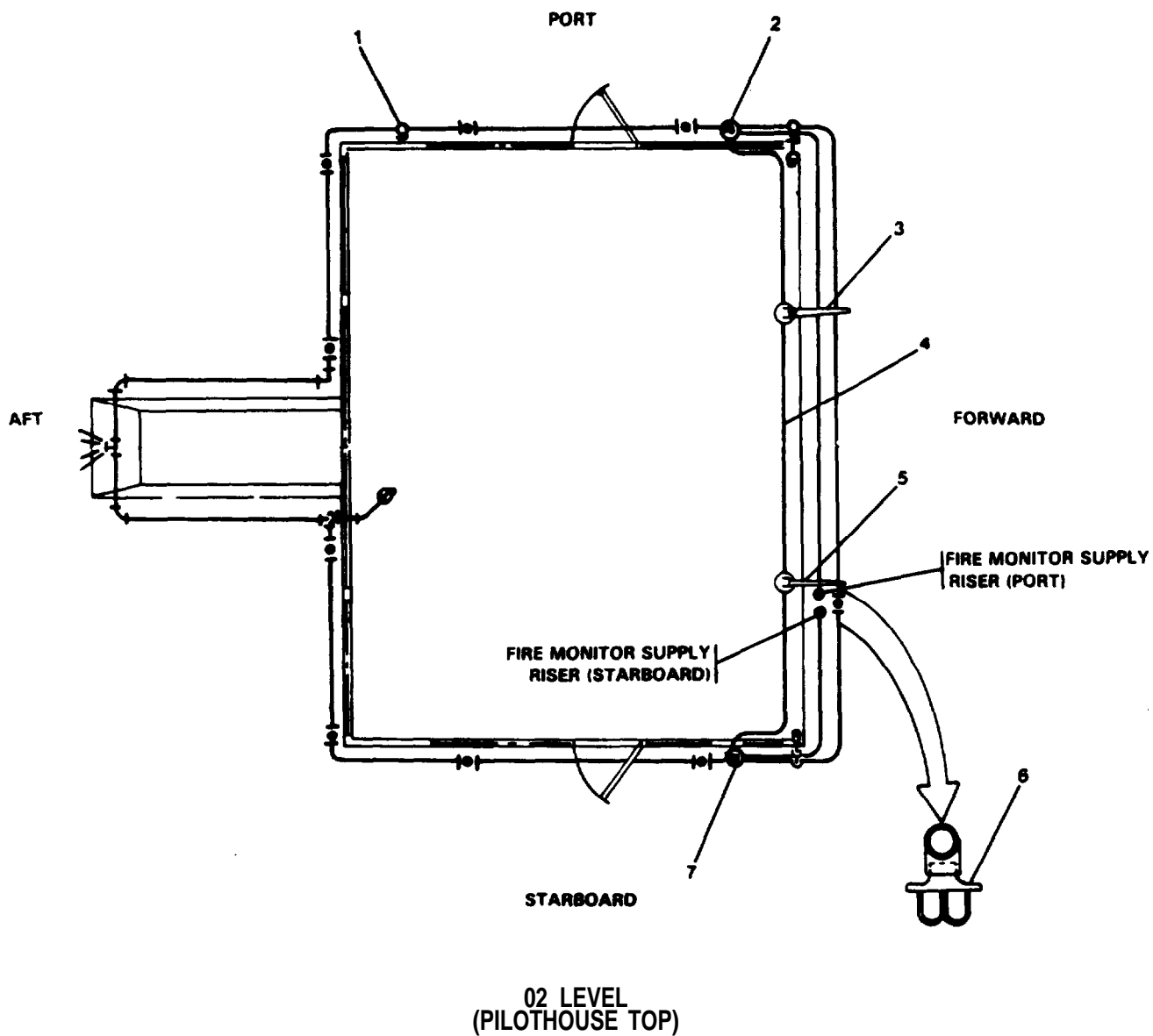
e. Countermeasure Washdown . The countermeasure washdown system (FIGURE 1-6) provides an umbrella of seawater over the superstructure to counter nuclear, biological, and chemical (NBC) attack. Seawater from the fire main is directed through washdown piping serving spray heads to wash down the superstructure. Spray heads and piping are located around the main deck (FIGURE 1-7), 01 (FIGURE 1-8) and 02 (FIGURE 1-5) levels. The system is activated by a valve in the engine room. Seawater for the system is routed out of the machinery space via a riser to the 01 level and a riser from the 01 level to the 02 level. Piping surrounding each level contains spray heads that disperse seawater. The system is activated from the fire main fire monitor and countermeasure washdown gate valve, located in the machinery space.

1-18. Autopilot. The autopilot is an automatic steering control system that uses heading information from the ship's gyrocompass to control the ship's steering gear. The autopilot energizes directional control valve solenoids, part of the ship's steering gear, in order to maintain selected heading. The autopilot heading selector combines the functions of a heading selector with a gyrocompass repeater. The heading selector contains controls that permit the selection of operating mode and desired heading. The autopilot control amplifier processes signals from the autopilot heading selector and the rudder repeatback unit to develop steering signals that are sent to the steering gear solenoids. This provides rudder control. The autopilot rudder repeatback unit sends signals from the steering gear, providing rudder position information, back to the autopilot control amplifier.

1-19. Navigation Lighting System. The navigation lighting system provides the appropriate exterior lights for safe navigation. The system is controlled from the navigation lighting panel located in the aft area of the pilothouse.

1-20. Sound Powered Telephone System. The sound powered telephone system provides voice communications throughout the ship. The system contains fixed phone stations and portable units. Since the system is powered by voice only, it is functional even with the loss of all ship's power. There are three circuits, JA, JV1, and JV2 within the sound powered telephone system.

1-21. Electrical System. The electrical system distributes 240 Vac, 120 Vac, and emergency power throughout the ship, 240 Vac, 3-phase, 60 Hz power is received from the power generation system ship's service diesel generator sets and routed via the main ship's service switchboard and the emergency switchboard via the emergency switchboard bus tie, to selected equipment and panels. 240 Vac power is also provided by the main switchboard to a stepdown transformer providing power to the 120 Vac distribution panel. This panel distributes 120 Vac power to a quarters heating panel, galley power panel, and lighting panels. Essential equipment and systems tied into the emergency switchboard normally receive power from the emergency switchboard via the bus tie. When 240 Vac power is lost, these equipments and systems receive 240 Vac power from the emergency diesel generator set through the emergency switchboard. The emergency switchboard also provides 120 Vac power through stepdown transformers to a 120 Vac distribution panel. This panel provides

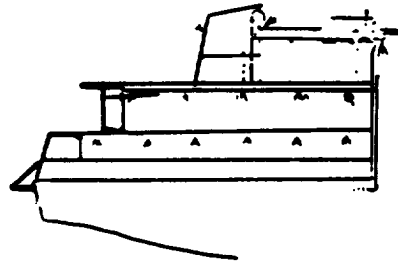


**LEGEND**

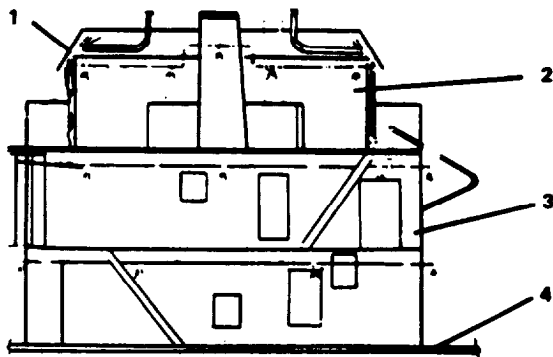
- |                                   |                                   |
|-----------------------------------|-----------------------------------|
| 1. COUNTMEASURE WASHDOWN SUPPLY   | 5. FIRE MONITOR (STARBOARD)       |
| 2. FIRE MONITOR SUPPLY FROM RISER | 6. SPRAY HEAD                     |
| 3. FIRE MONITOR (PORT)            | 7. FIRE MONITOR SUPPLY FROM RISER |
| 4. FIRE MONITOR SUPPLY LINE       |                                   |

FIGURE 1-5 Fire Monitor and Countermeasure Washdown Piping System-02 Level

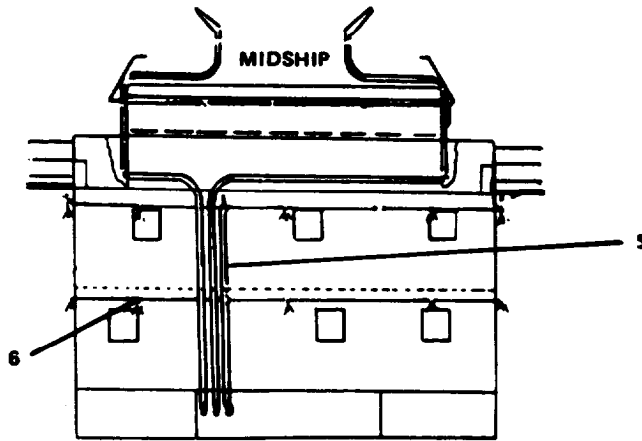




STARBOARD SIDE



AFT



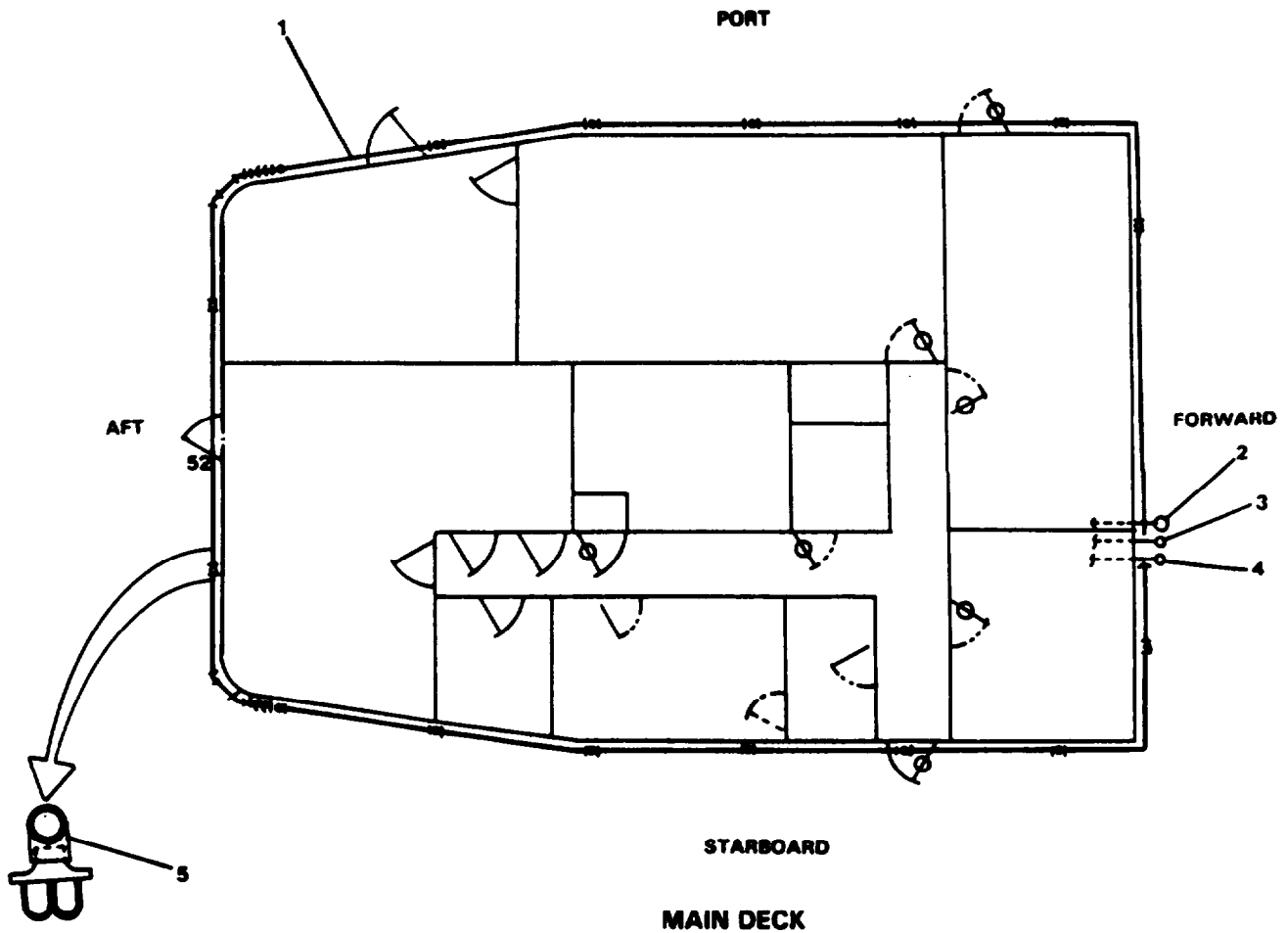
FORWARD

LEGEND

- 1. PILOT HOUSE TOP
- 2. 02 LEVEL
- 3. 01 LEVEL

- 4. MAIN DECK
- 5. WASHDOWN PIPING
- 6. SPRAY HEAD

FIGURE 1-6. Countermeasure Washdown.

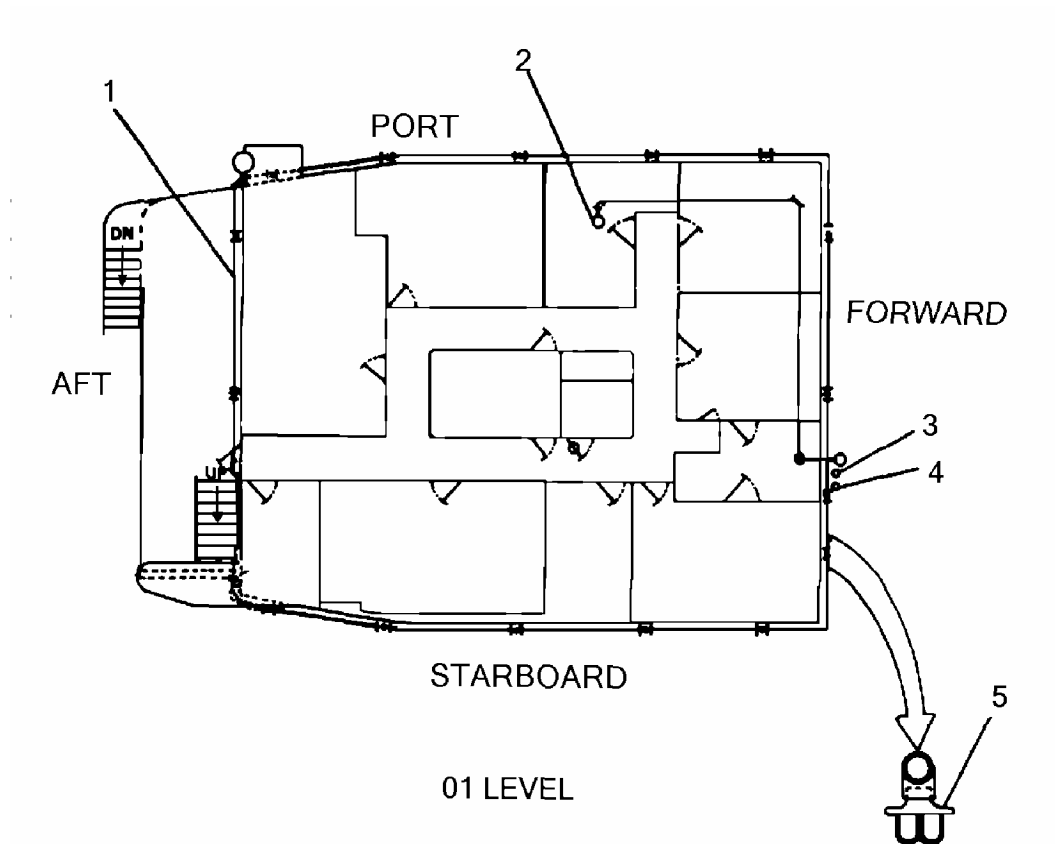


LEGEND

- 1. COUNTERMEASURE WASHDOWN SUPPLY
- 2. COUNTERMEASURE WASHDOWN SUPPLY RISER

- 3. FIRE MONITOR SUPPLY RISER (PORT)
- 4. FIRE MONITOR SUPPLY RISER (STARBOARD)
- 5. SPRAY HEAD

FIGURE 1-7. Fire Monitor and Countermeasure Washdown Piping System-Main Deck.



**LEGEND**

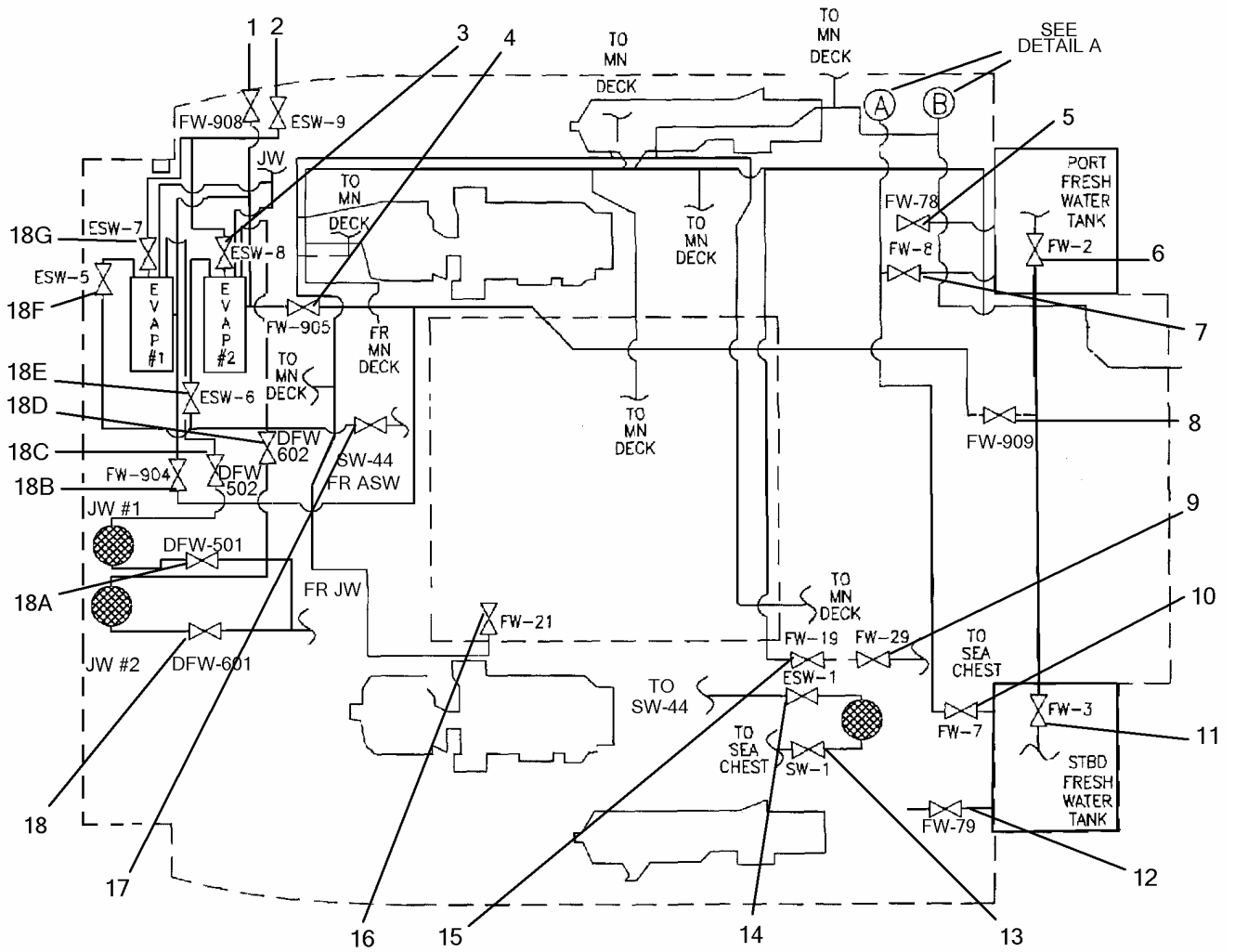
- |  |                              |
|--|------------------------------|
| 1. COUNTERMEASURE WASHDOWN SUPPLY                            | 3. FIRE MONITOR RISER (PORT) |
| 2. COUNTERMEASURE WASHDOWN SUPPLY (STARBOARD) FROM MAIN DECK | 4. FIRE MONITOR RISER        |
|  | 5. SPRAY HEAD                |

Figure 1-8. Fire Monitor and Countermeasure Washdown Piping System - 01 Level.

120 Vac power to the emergency switchboard battery charger, which charges the emergency switchboard 24 Vdc batteries, providing voltage to the 24 Vdc distribution panel. This panel provides 24 Vdc power to those systems required to maintain propulsion control, and communication. When tied to shore power through the shore power box, power distribution is the same as provided for primary power. Refer to FO-1 for electrical power distribution.

**1-22. Fresh Water Piping System.** The fresh water piping system provides cold and hot potable water throughout the LCU. System control is maintained through a combination of valves as shown in FIGURE 1-9. The system consists of two Waste Heat Evaporators (WHE), two distillate water pumps, two fresh water (FW) pumps and pressure switches, a pressure tank, hot water heater, and fresh water tank level indicator transmitters. Also included is a hot water booster pump and hot water booster heater for the Gaylord Hood. The FW tanks are filled and vented through fill and vent connections on the main weather deck. Each FW tank has a drain to the bilge. In addition to the potable water system, cold fresh water (CFW) is supplied to the fresh water cooling piping system.

- a. Waste Heat Evaporator. Two waste heat evaporators (EVAPs) take seawater from the sea chest and, through low pressure evaporation, separate dissolved solids from the seawater and supply fresh water to the port and starboard fresh water tanks. Brine is discharged overboard from the evaporators. Power is supplied to the waste heat evaporators from the MCC 227 (EVAP), and can only be started at the evaporator stations and monitored in the engine room console.
- b. FW Pumps No. 1 and No. 2. Two FW pumps draw CFW from the port and starboard FW tanks and route the CFW under pressure to the hydro pneumatic pressure tank, which maintains CFW pressure throughout the system. Power for the pumps is supplied from the main switchboard 240 Vac distribution, and controlled by start and stop pushbuttons on the engine room console and by pressure switches. One pump (main) is on line and the other (standby) is in reserve.
- c. Pressure Switches. Each FW pump pressure switch automatically turns on its respective FW pump when pressure drops below the cut-in set point (pump 1-35 psi, pump 2-30 psi). Each FW pump pressure switch automatically turns off its respective FW pump when pressure exceeds 60 psi.
- d. Pressure Tank. The hydro pneumatic pressure tank maintains CFW supply pressure for the system. Pressurized CFW is supplied from the pressure tank to various points throughout the ship and to the hot water heater.
- e. Hot Water Heater. The hot water heater heats the CFW supply and maintains its set point temperature. Power for the hot water heater is supplied from the main switchboard 240 Vac distribution panel and controlled by a disconnect switch adjacent to the heater. Hot fresh water (HFW) from the heater is supplied to the booster pump.
- f. Booster Pump. The booster pump maintains HFW pressure required for the Gaylord Hood system.
- g. Booster Heaters. Two booster heaters provide an increase in HFW temperature for use in the galley (dishwasher and hood). Both booster heaters are supplied with power from the GALLEY POWER PANEL P202.
- h. Tank Level Indicator Transmitters. Each FW tank contains a tank level indicator transmitter which sends a tank level signal to the gauge board in the engine room which indicates each FW tank level.
- i. Distillate pumps No.1 and No. 2. Two distillate pumps draw distilled water from the evaporators and route it to the FW tanks. Power for the pumps is supplied by the auxiliary machinery motor control center P205, and START/STOP pushbuttons adjacent to the evaporator.



BELOW MAIN DECK (ENGINE ROOM)

Figure 1-9. Fresh Water Piping System (Sheet 1 of 8).

DETAIL A

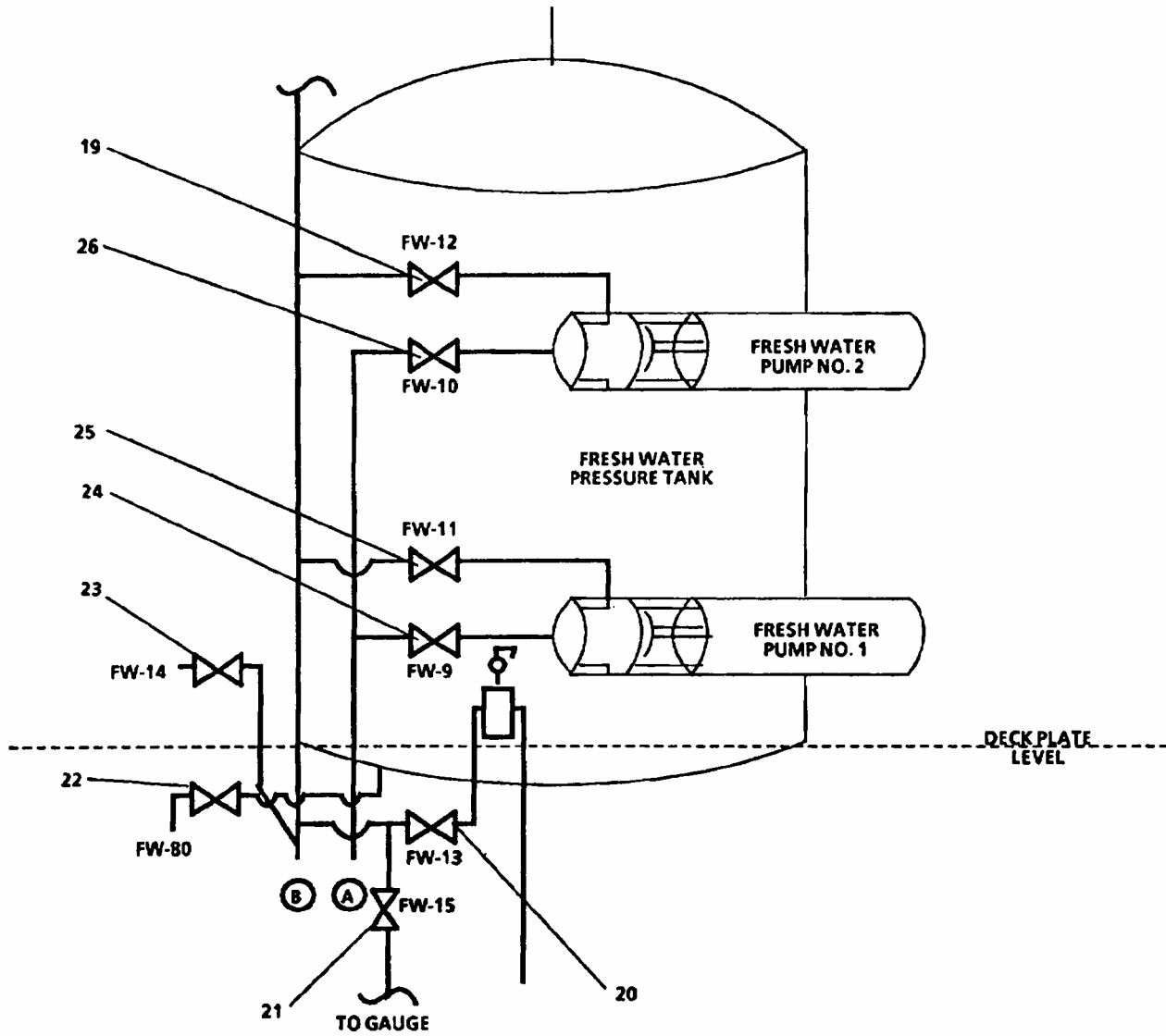


Figure 1-9. Fresh Water Piping System (Sheet 2 of 8).

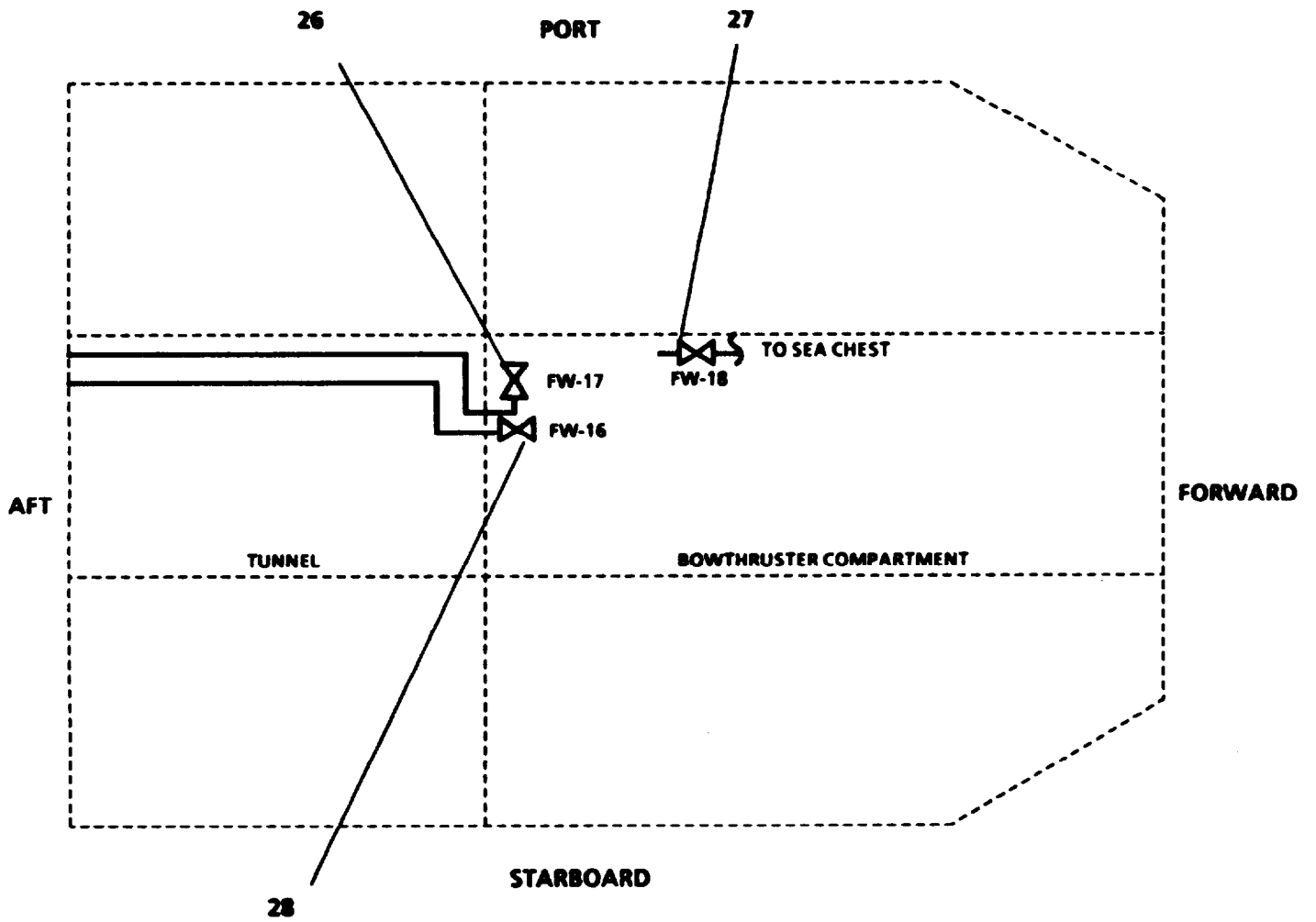


FIGURE 1-9. Fresh Water Piping System (Sheet 3 of 8) .

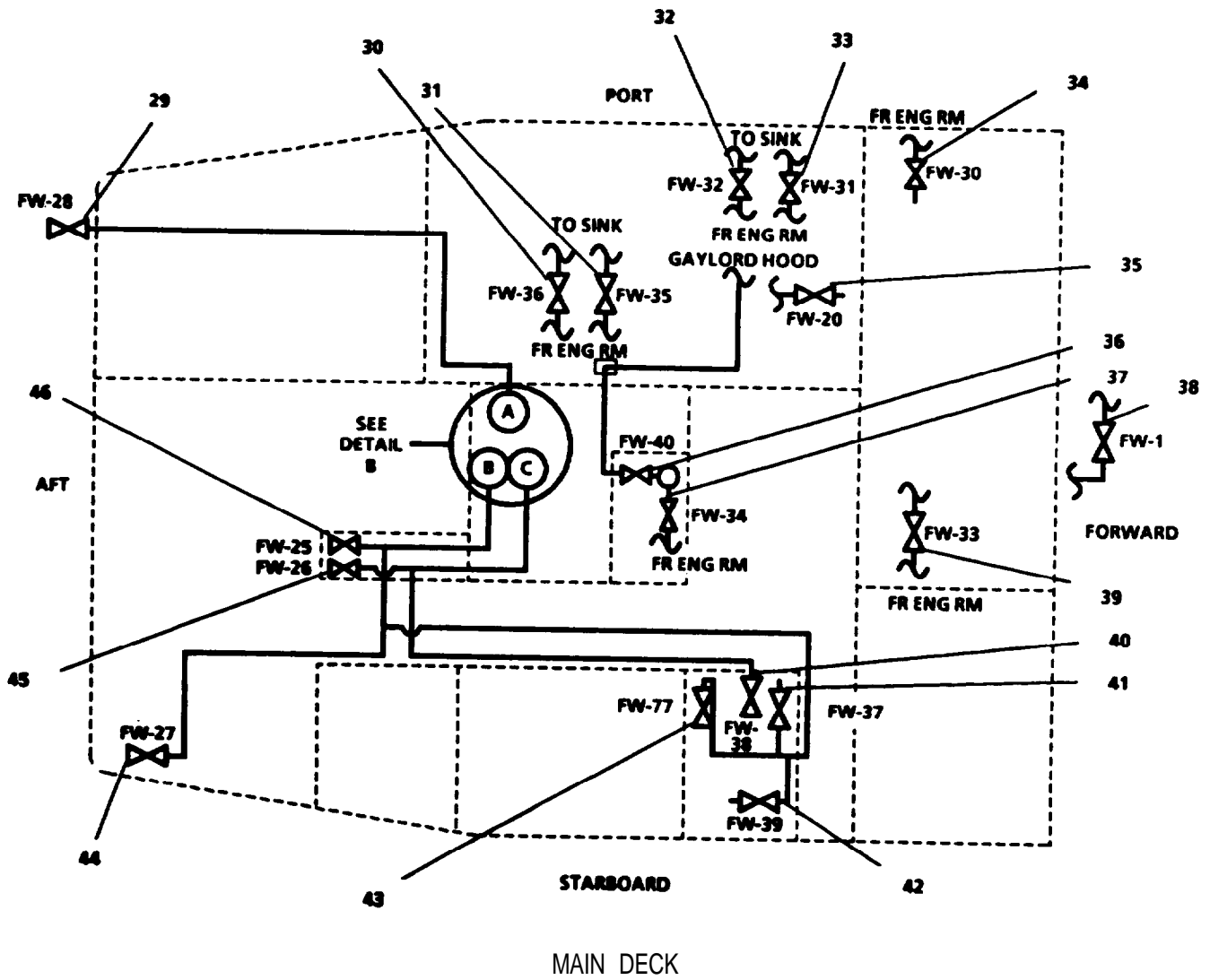


Figure 1-9. Fresh Water Piping System (Sheet 4 of 8)



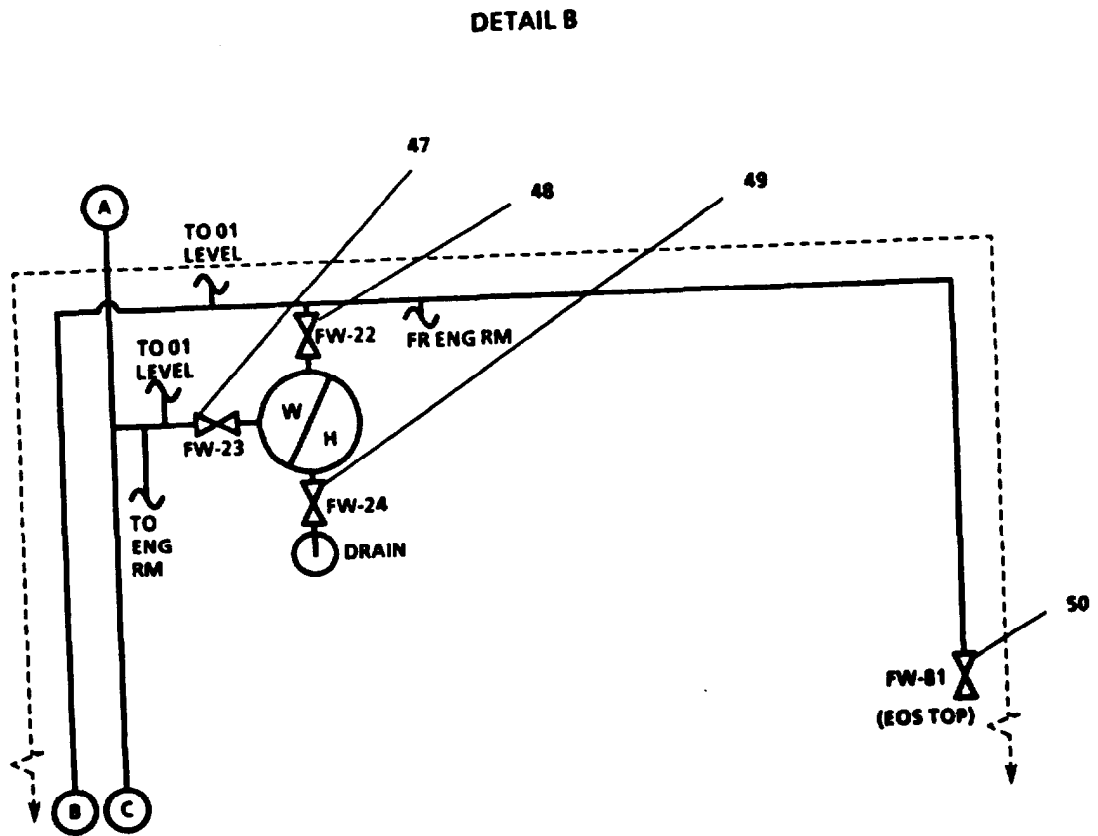


FIGURE 1-9. Fresh Water Piping System (Sheet 5 of 8).

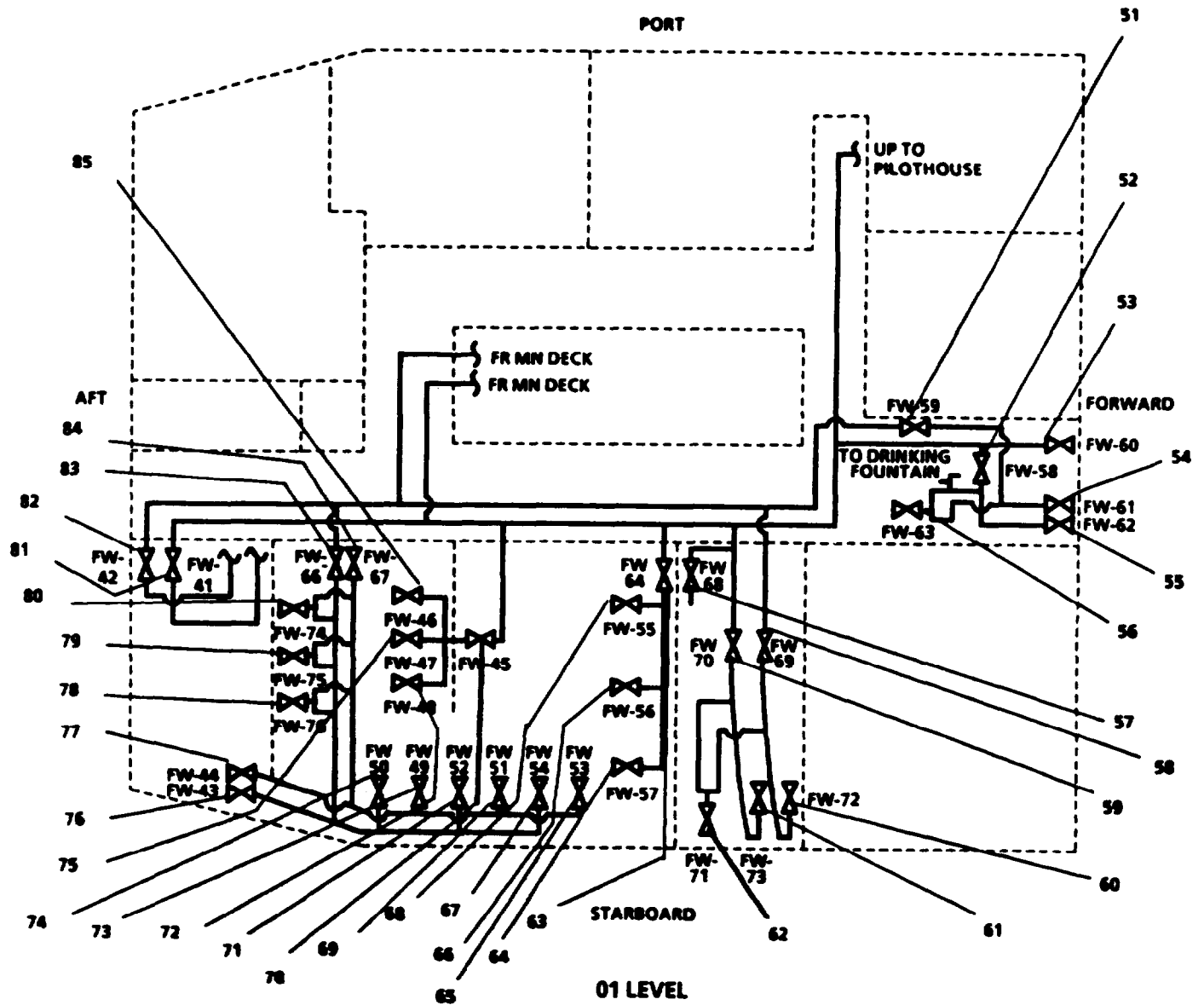


FIGURE 1-9. Fresh Water Piping System (Sheet 6 of 8).

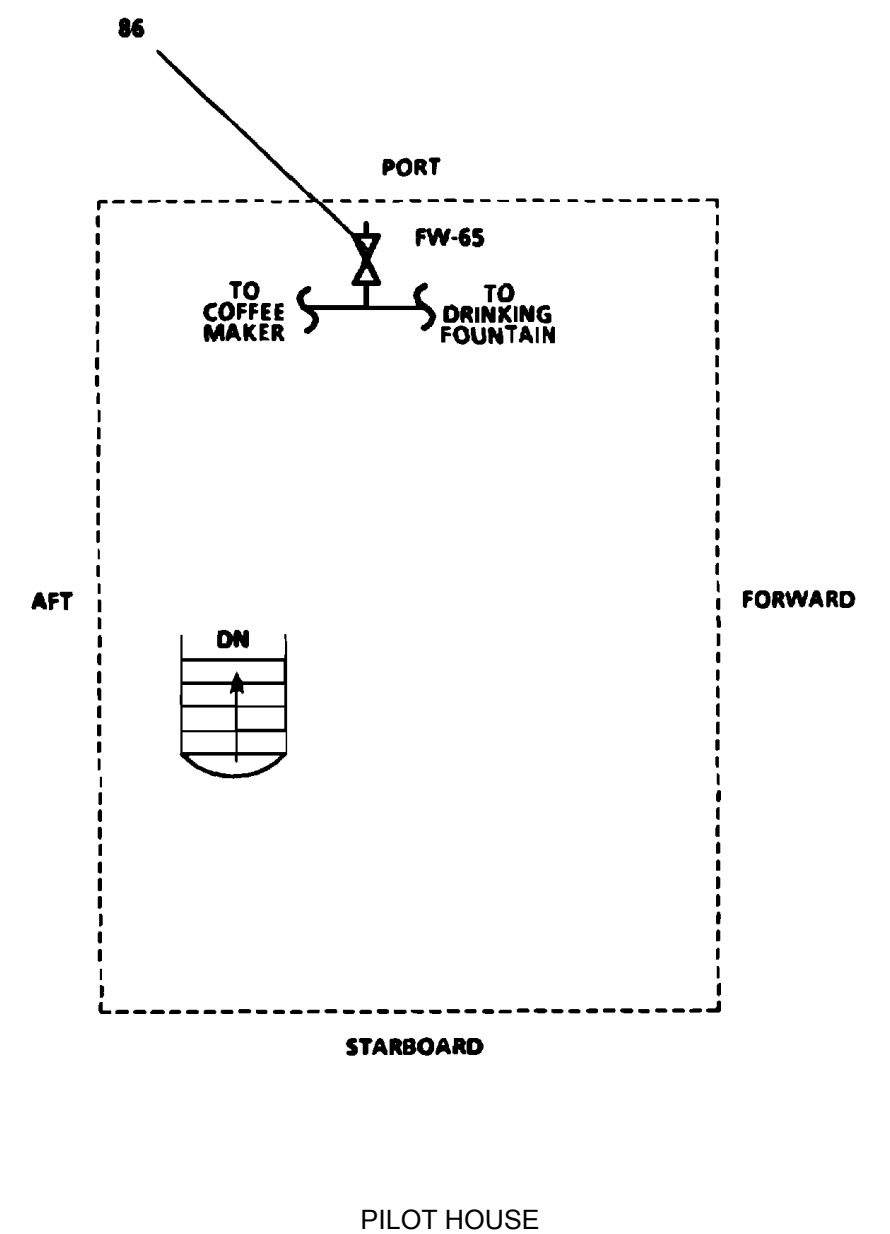


Figure 1-9. Fresh Water Piping System (Sheet 7 of 8).

LEGEND

- |   |  |
|---|--|
| <ol style="list-style-type: none"> <li>1. FW-908, WASTE DISTILLATE OVERBOARD</li> <li>2. ESW-9, EVAP BRINE OVERBOARD</li> <li>3. ESW-8, NO. 2 EVAP SEAWATER OUTLET</li> <li>4. FW-905, FW SUPPLY FROM NO. 2 EVAP</li> <li>5. FW-78, DRAIN-TK FW-6P</li> <li>6. FW-2, FILL ISLN-TK FW-6P</li> <li>7. FW-8, ISLN/SUCT-TK FW-6P</li> <li>8. FW-909, FW TO TANK FILL LINE</li> <li>9. FW-29, SEA CHEST-HOT FW CONNECTION</li> <li>10. FW-7, ISLN/SUCT-TK FW-6S</li> <li>11. FW-3, FILL ISLN-TK FW-6S</li> <li>12. FW-79, DRAIN-TK FW-6S</li> <li>13. SW-1, SUPPLY TO PUMP</li> <li>14. ESW-1, ISLN-SW SUPPLY TO FW MAKERS</li> <li>15. FW-19, HOT FW HOSE CONN</li> <li>16. FW-21, COLD FW TO DF &amp; COFFEE MAKER-<br/>ENG RM</li> <li>17. SW-44, EVAP SYS SUPPLY FROM ASW SYS</li> <li>18. DFW-601, NO. 2 JW PUMP INLET ISLN</li> <li>18A. DFW-501, NO. 1 JW PUMP INLET ISLN</li> <li>18B. FW-904, FW SUPPLY FROM NO. 1 EVAP</li> <li>18C. DFW-502, NO. 1 JW PUMP OUTLET ISLN</li> <li>18D. DFW-602, NO. 2 JW PUMP OUTLET ISLN</li> <li>18E. ESW-6, NO. 2 EVAP SEAWATER SUPPLY</li> <li>18F. ESW-5, NO. 1 EVAP SEAWATER SUPPLY</li> <li>18G. ESW-7, NO. 1 EVAP SEAWATER OUTLET</li> <li>19. FW-12, FW PUMP NO. 2 DISCH</li> <li>20. FW-13, FW PRESS TK ISLN-</li> <li>21. FW-15, CO PRESS GAGE-FW SYS</li> <li>22. FW-14, COLD FW HOSE CONN</li> <li>23. FW-9, FW PUMP NO. 1 SUCT FR FW TKS</li> <li>24. FW-11, FW PUMP NO. 1 DISCH</li> <li>25. FW-10, FW PUMP NO. 2 SUCT FR FW TKS</li> <li>26. FW-17, HOT FW HOSE CONN</li> <li>27. FW-18, SEA CHEST - HOT FW CONN</li> <li>28. FW-16, COLD FW HOSE CONN</li> <li>29. FW-20, HOT FW WASHDOWN</li> <li>30. FW-36, HOT FW TO AFT GALLEY SINK</li> <li>31. FW-35, COLD FW TO AFT GALLEY SINK</li> <li>32. FW-32, HOT FW TO FWD GALLEY SINK</li> <li>33. FW-31, COLD FW TO FWD GALLEY SINK</li> <li>34. FW-30, COLD FW TO DF (MESS DK)</li> <li>35. FW-20, HOT FW TO DISHWASHER</li> <li>36. FW-40, GAYLORD PUMP DISCH</li> <li>37. FW-34, COLD FW TO GAYLORD HOOD PUMP</li> <li>38. FW-1, FILL CONN-FW TKS</li> <li>39. FW-33, COLD FW TO BVGE &amp; COFFEE<br/>MAKER (MESS DK)</li> </ol> | <ol style="list-style-type: none"> <li>40. FW-38, HOT FW TO SICKBAY SINK</li> <li>41. FW-37, COLD FW TO SICKBAY SINK</li> <li>42. FW-39, SUPPLY TO WC</li> <li>43. FW-77, SUPPLY TO SH</li> <li>44. FW-27, COLD FW HOSE CONN</li> <li>45. FW-26, HOT FW TO CG LKR SINK</li> <li>46. FW-25, COLD FW TO CG LKR SINK</li> <li>47. FW-23, HOT FW DISCH FR WTR HTR</li> <li>48. FW-22, COLD FW TO WTR HTR</li> <li>49. FW-24, WTR HTR DRAIN</li> <li>50. FW-81, EXP TK FILL</li> <li>51. FW-59, HOT FW ISLN</li> <li>52. FW-58, COLD FW ISLN</li> <li>53. FW-60, SUPPLY TO WC</li> <li>54. FW-61, SUPPLY TO WC</li> <li>55. FW-62, COLD FW TO SINK</li> <li>56. FW-63, SUPPLY TO SH</li> <li>57. FW-68, SUPPLY TO WC</li> <li>58. FW-69, COLD FW ISLN</li> <li>59. FW-70, ISLN-HOT FW</li> <li>60. FW-72, COLD FW TO SINK</li> <li>61. FW-73, HOT FW TO SINK</li> <li>62. FW-71, SUPPLY TO SH</li> <li>63. FW-64, ISLN-WC</li> <li>64. FW-57, SUPPLY TO WC</li> <li>65. FW-53, COLD FW TO SINK</li> <li>66. FW-56, SUPPLY TO WC</li> <li>67. FW-54, HOT FW TO SINK</li> <li>68. FW-55, SUPPLY TO WC</li> <li>69. FW-51, COLD FW TO SINK</li> <li>70. FW-45, ISLN URINAL</li> <li>71. FW-52, HOT FW TO SINK</li> <li>72. FW-48, SUPPLY TO URINAL</li> <li>73. FW-49, COLD FW TO SINK</li> <li>74. FW-50, HOT FW TO SINK</li> <li>75. FW-47, SUPPLY TO URINAL</li> <li>76. FW-43, COLD FW TO WASHER</li> <li>77. FW-44, HOT FW TO WASHER</li> <li>78. FW-76, SUPPLY TO SH</li> <li>79. FW-75, SUPPLY TO SH</li> <li>80. FW-74, SUPPLY TO SH</li> <li>81. FW-41, COLD FW TO LAU SINK</li> <li>82. FW-42, HOT FW TO LAU SINK</li> <li>83. FW-66, ISLN-HOT FW</li> <li>84. FW-67, ISLN-COLD FW</li> <li>85. FW-46, SUPPLY TO URINAL</li> <li>86. FW-65, COLD FW TO DF</li> </ol> |
|---|--|

Figure 1-9. Fresh Water Piping System (Sheet 8 of 8).

**1-23. Bilge/Ballast and Firemain Piping System.** The bilge/ballast and firemain piping systems remove accumulated water from the bilges, transfers seawater to and from seawater ballast tanks, and supplies seawater to the firemain, countermeasure washdown (CMWD), and AFFF foam proportioners.

- a. **Bilge/Ballast Piping System.** The bilge/ballast piping system (FIGURE 1-10) draws bilge water from selected ship bilges and discharges it overboard. The system also draws seawater from the sea chest and distributes it to selected ballast (seawater) tanks and draws seawater from the ballast tanks and discharges it overboard, or to another ballast tank. In an extreme emergency, the bilge/ballast piping system can be aligned to supply ballast water to the firemain. System control is maintained through a combination of valves as shown in FIGURE 1-10. The system consists of the bilge/ballast pump, bilge manifold, and ballast manifold. Power for the bilge/ballast pump is supplied from the main switchboard 240 Vac distribution panel and controlled by start and stop pushbuttons on the engine room console.
- b. **Fire Main and Foam Piping System.** The fire main and foam piping system (FIGURE 1-11) draws seawater from the sea chest to pressurize the fire main, countermeasure washdown (CMWD) and AFFF foam proportioners. System control is maintained through a combination of valves as shown in FIGURE 1-11. The system consists of fire pumps No. 1 and No. 2, and an auxiliary fire pump. The fire main supplies seawater to fire stations, the countermeasure washdown station, and the AFFF foam proportioners. Power to fire pumps No. 1 and No. 2 is supplied by the main switchboard 240 Vac distribution panel. Control of the pumps is provided from start and stop pushbuttons adjacent to the pumps or from stop and start pushbuttons on the engine room console. The auxiliary fire pump will also pressurize the fire main. This pump is powered by the bow thruster/auxiliary fire pump diesel engine.

**1-24. Seawater Cooling Piping System.** The seawater cooling piping system (FIGURE 1-12) provides seawater for cooling and air conditioning units AC-1, AC-2, and AC-3. Seawater is also provided to the port and starboard stern tubes for lubrication, cooling, and flushing, the oil water separator, the waste heat evaporator (FIGURE 1-9) and the marine sanitation device. System control is maintained through a combination of valves as shown in FIGURE 1-12. The system consists of the auxiliary seawater cooling pump and a duplex strainer in the piping, drawing seawater from the sea chest. The seawater regulating valves located in the emergency generator room provide a constant air conditioner condenser cooling water pressure. The seawater cooling pump receives power through the auxiliary machinery motor control center with a RUN indicator lamp on the EOS.

**1-25. Hydraulic Oil Supply Piping System.** The hydraulic oil supply piping system (FIGURE 1-13) replenishes the hydraulic oil storage tank and supplies hydraulic oil to supply points in the following compartments: boatswain storeroom, bow thruster room, and steering gear room. The supply points provide hydraulic oil for the following:

- a. **Boatswain Storeroom.** Bow ramp winch hydraulic power pack and starboard bow anchor windlass hydraulic power pack.
- b. **Bow Thruster Room.** Port bow anchor windlass hydraulic power pack and bow thruster hydraulic power pack.
- c. **Steering Gear Room.** Port side - Steering gear hydraulic power pack and Starboard side - Stern anchor winch hydraulic power pack.

Supply points are replenished by pressurizing the supply line with the hand pump and filling containers at the supply points.

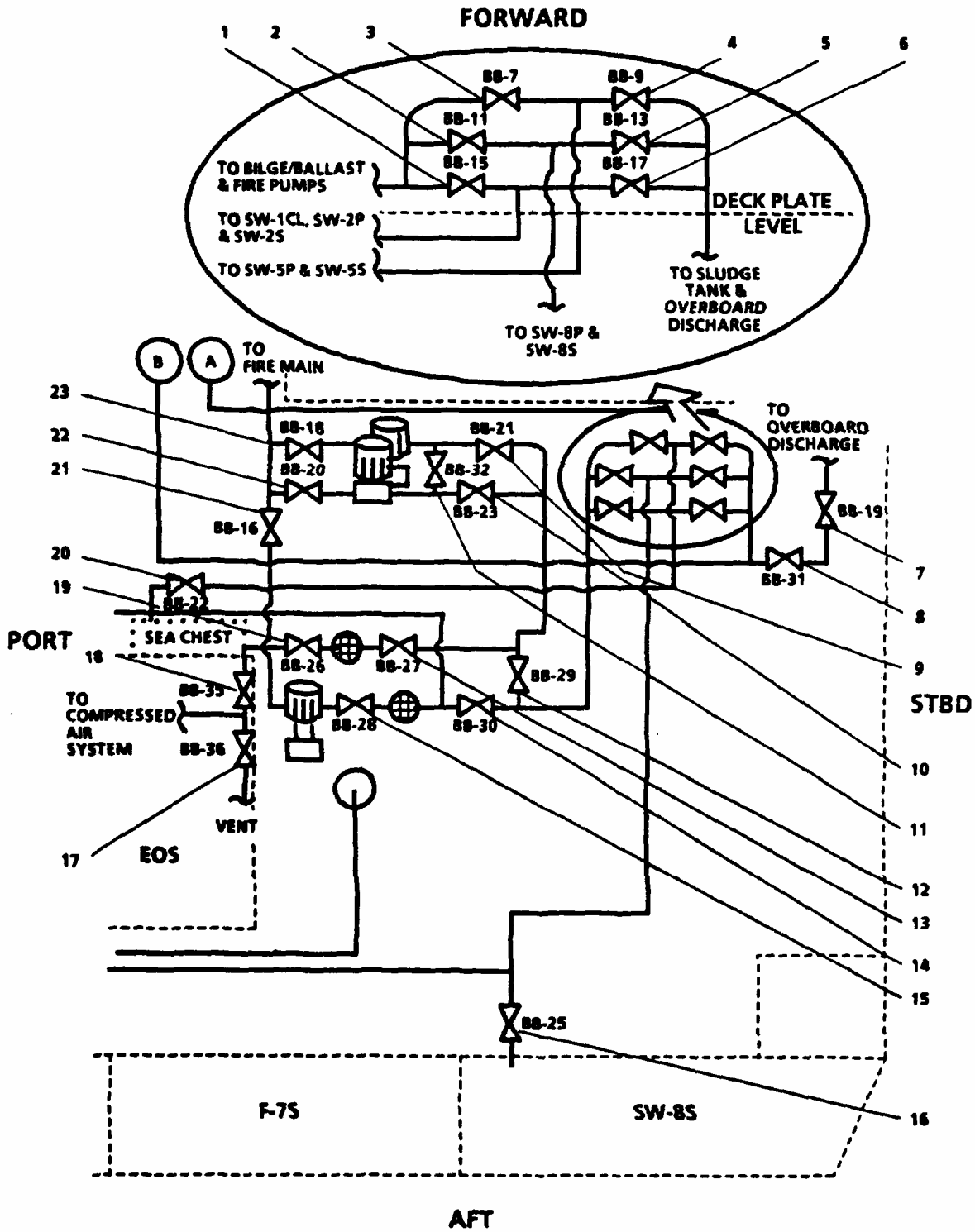


Figure 1-10. Bilge/Ballast Piping System (Sheet 1 of 4).

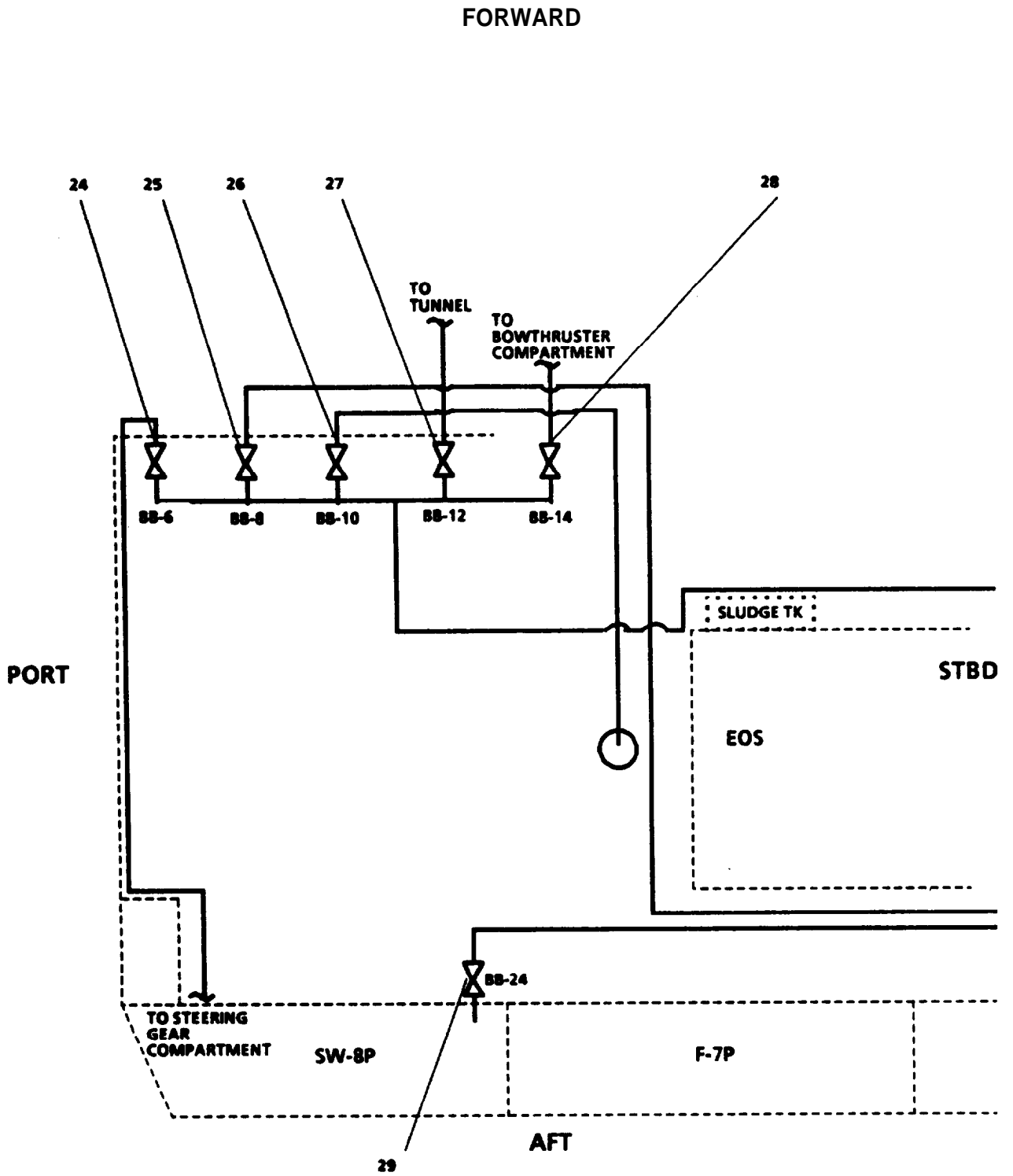


FIGURE 1-10. Bilge/Ballast Piping System (Sheet 2 of 4).

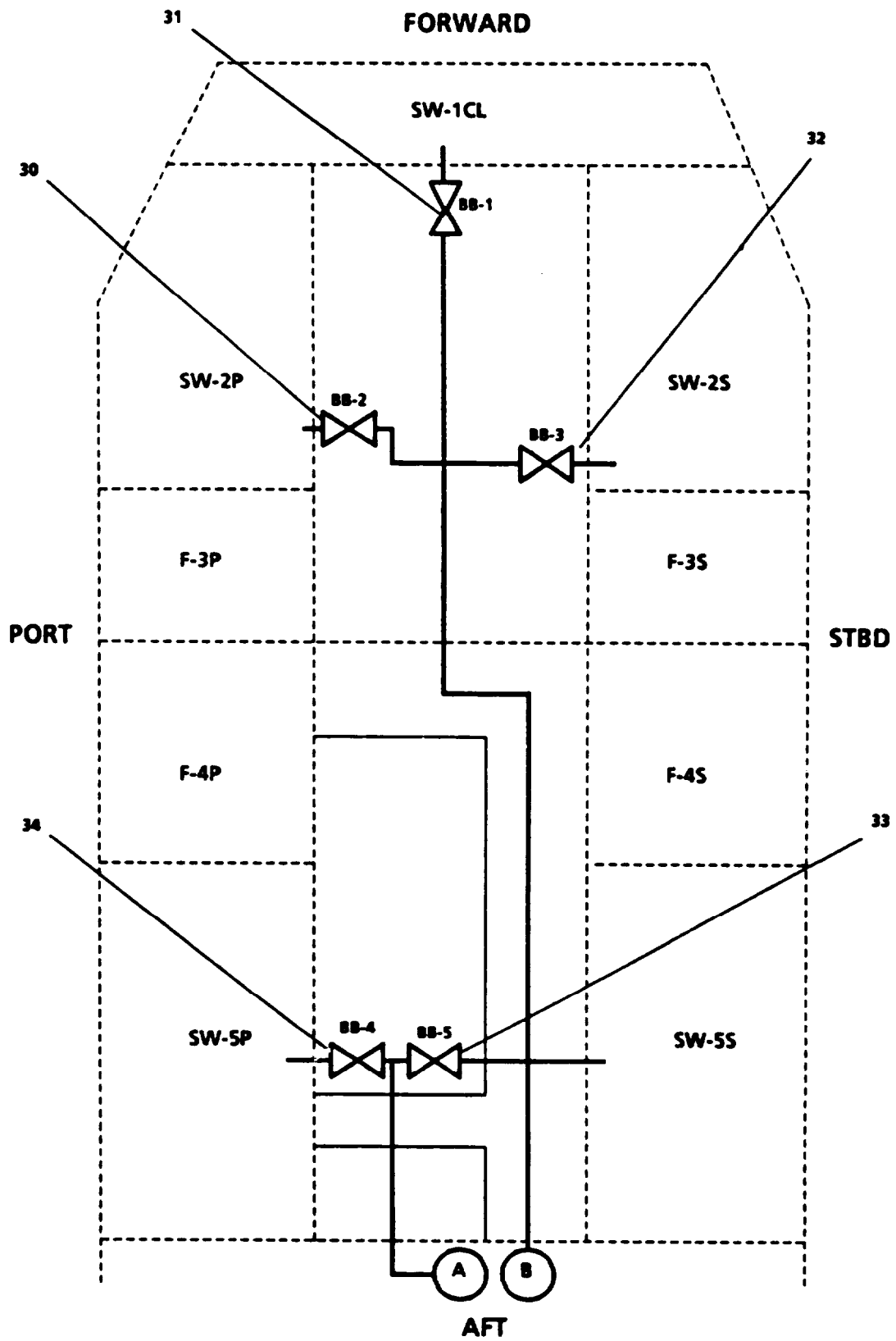
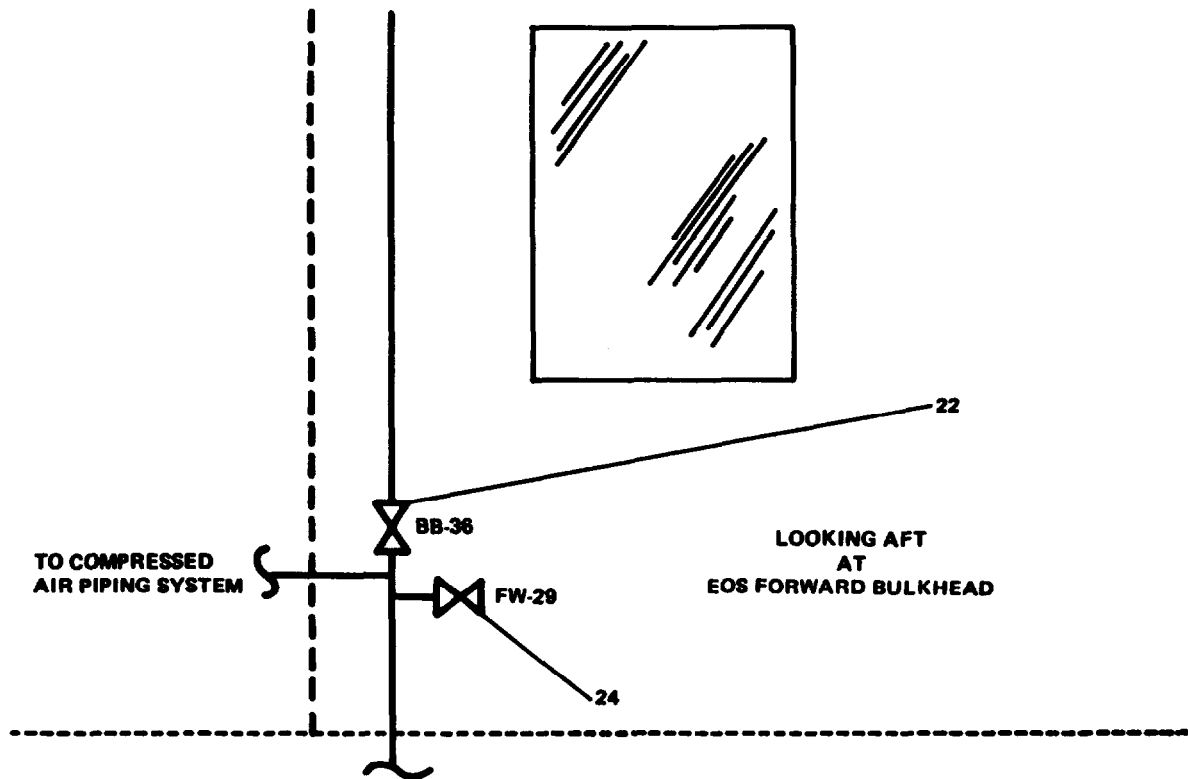


FIGURE 1-10. Bilge/Ballast Piping System (Sheet 3 of 4).



DETAIL E



LEGEND

- |   |  |
|---|--|
| 1. BB-15, SUCT FR SW-1 & SW-2S & SW-2P        | 21. BB-22, ISLN - SEA CHEST                            |
| 2. BB-11, SUCT FR SW-8S & SW-8P               | 22. BB-23, SEA CHEST SUCT                              |
| 3. BB-7, SUCT FR SW-5S & SW-5P                | 23. BB-36, SEA CHEST VENT                              |
| 4. BB-9, SUPPLY TO SW-5S & SW-5P              | 24. BB-35, SEA CHEST VENT ISOLATION                    |
| 5. BB-13, SUPPLY TO SW-8S & SW-8P             | 25. FW-29, SEA CHEST HOT FW CONN                       |
| 6. BB-17, SUPPLY TO SW-1 & SW-2S & SW-2P      | 26. BB-37, CROSS CONN TO BILGE MANIFOLD                |
| 7. BB-18, TO OVBD DISCH                       | 27. BB-38, CROSS CONN FIRE PUMP SUCT TO BILGE MANIFOLD |
| 8. BB-27, TO OVBD DISCH                       | 28. FM-13, FIREMAN & BALLAST CROSS CONN                |
| 9. PRESSURE GAUGE ISOLATION                   | 29. BB-6, BILGE SUCT-STRG GR COMPT                     |
| 10. FM-15, NO. 2 FIRE PUMP DISCH              | 30. BB-8, BILGE SUCT-ENG RM STBD                       |
| 11. FM-14, NO. 1 FIRE PUMP DISCH              | 31. BB-10, BILGE SUCT-ENG RM PORT                      |
| 12. FM-16, FIRE PUMP 1 & 2 SUCT CROSS CONN    | 32. BB-12, BILGE SUCT-TUNNEL                           |
| 13. FM-17, FIRE PUMP NO. 2 SUCT               | 33. BB-14, BILGE SUCT BOWTHRUSTER ENG RM               |
| 14. FM-26, NO. 2 FIRE PUMP STRAINER ISOLATION | 34. BB-19, DISCH TO SLUDGE TK                          |
| 15. FM-25, NO. 1 FIRE PUMP STRAINER ISOLATION | 35. BB-20, ISLN-TK SW-8P                               |
| 16. FM-18, FIRE PUMP NO. 1 SUCT               | 36. BB-2, ISLN TK SW-2P                                |
| 17. FM-27, ENG RM EMERG BILGE SUCT            | 37. BB-1, ISLN TK SW-1                                 |
| 18. BB-25, ISLN-SEA CHEST                     | 38. BB-3, ISLN TK SW-2S                                |
| 19. BB-21, ISLN-TK SW-8S                      | 39. BB-5, ISLN TK SW-5S                                |
| 20. BB-24, SUCT-BILGE/BALLAST PUMP            | 40. BB-4, ISLN TK SW-5P                                |

FIGURE 1-10. Bilge/Ballast Piping System (Sheet 4 of 4).

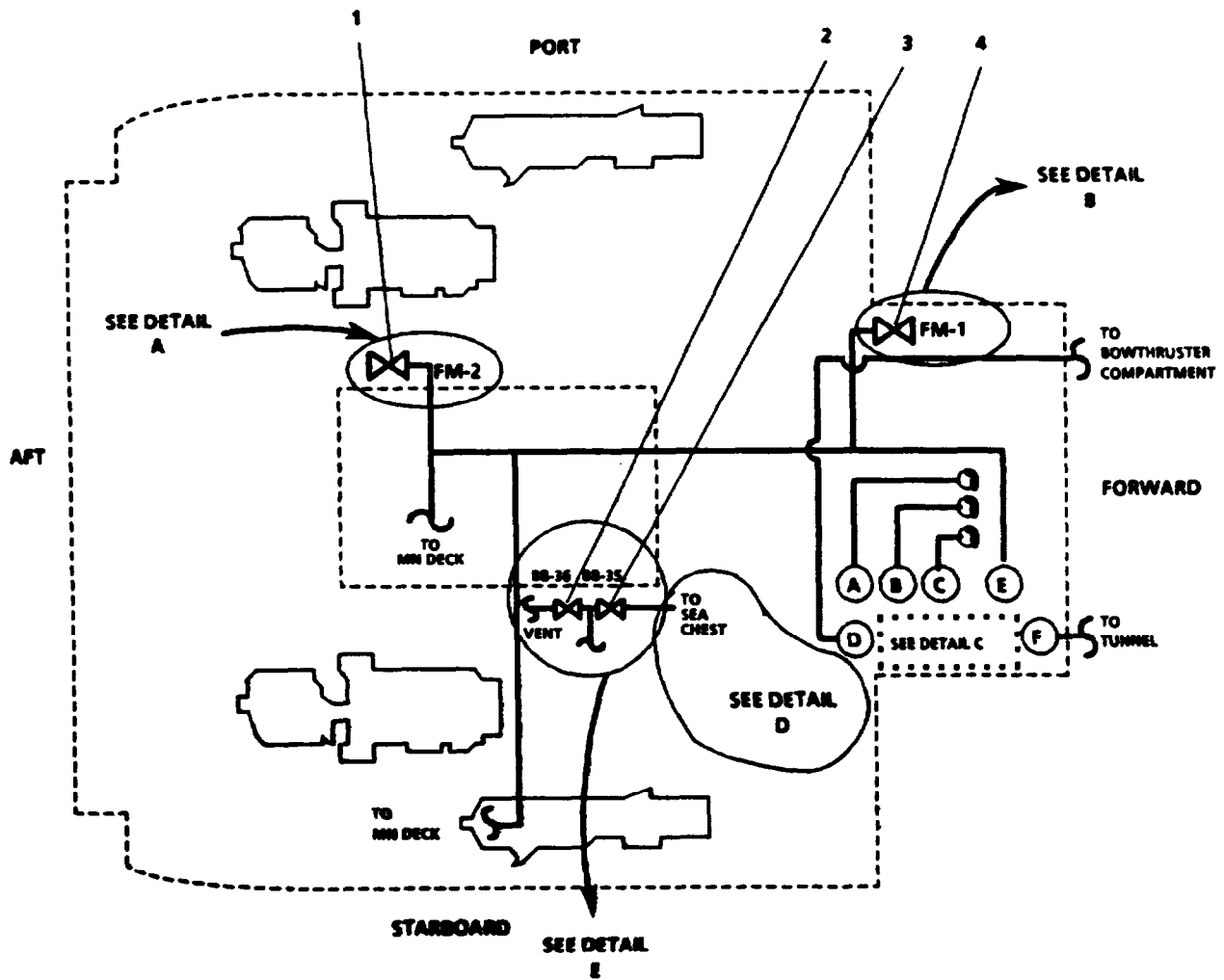


FIGURE 1-11. Fire Main and Foam Piping System (Sheet 1 of 8).

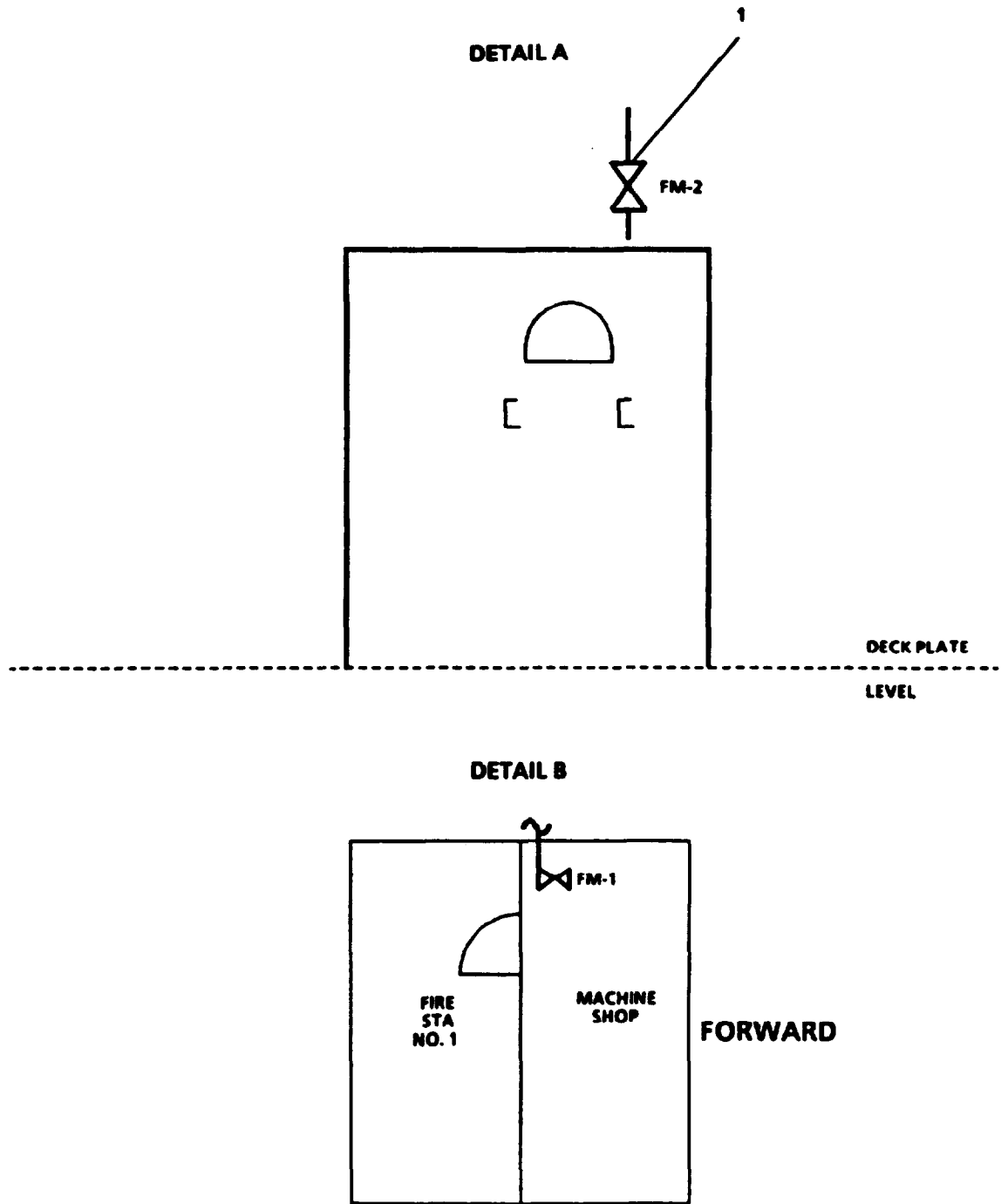
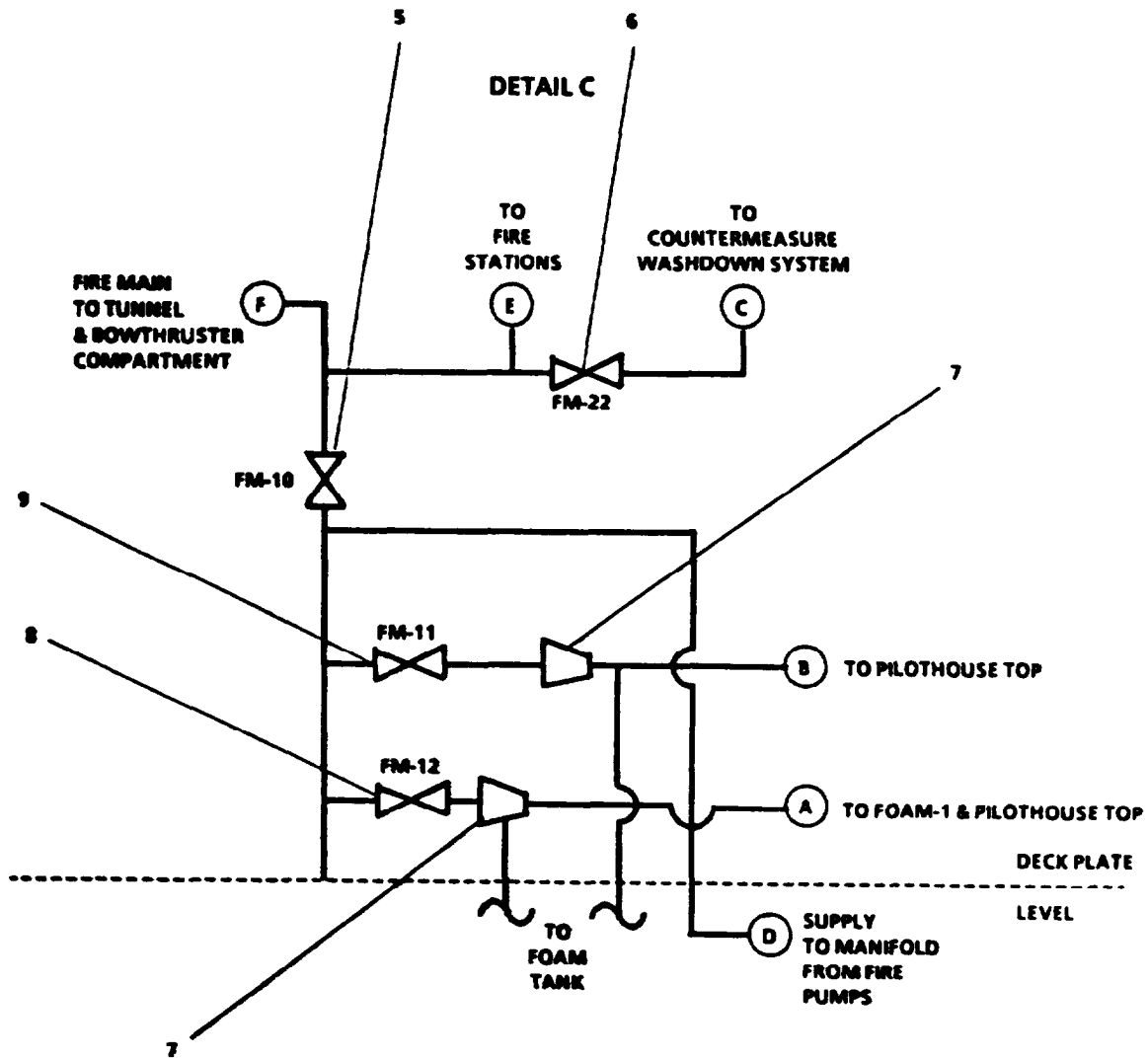


FIGURE 1-11. Fire Main and Foam Piping System (Sheet 2 of 8).



LOOKING STARBOARD AT PORT BULKHEAD OF STOREROOM

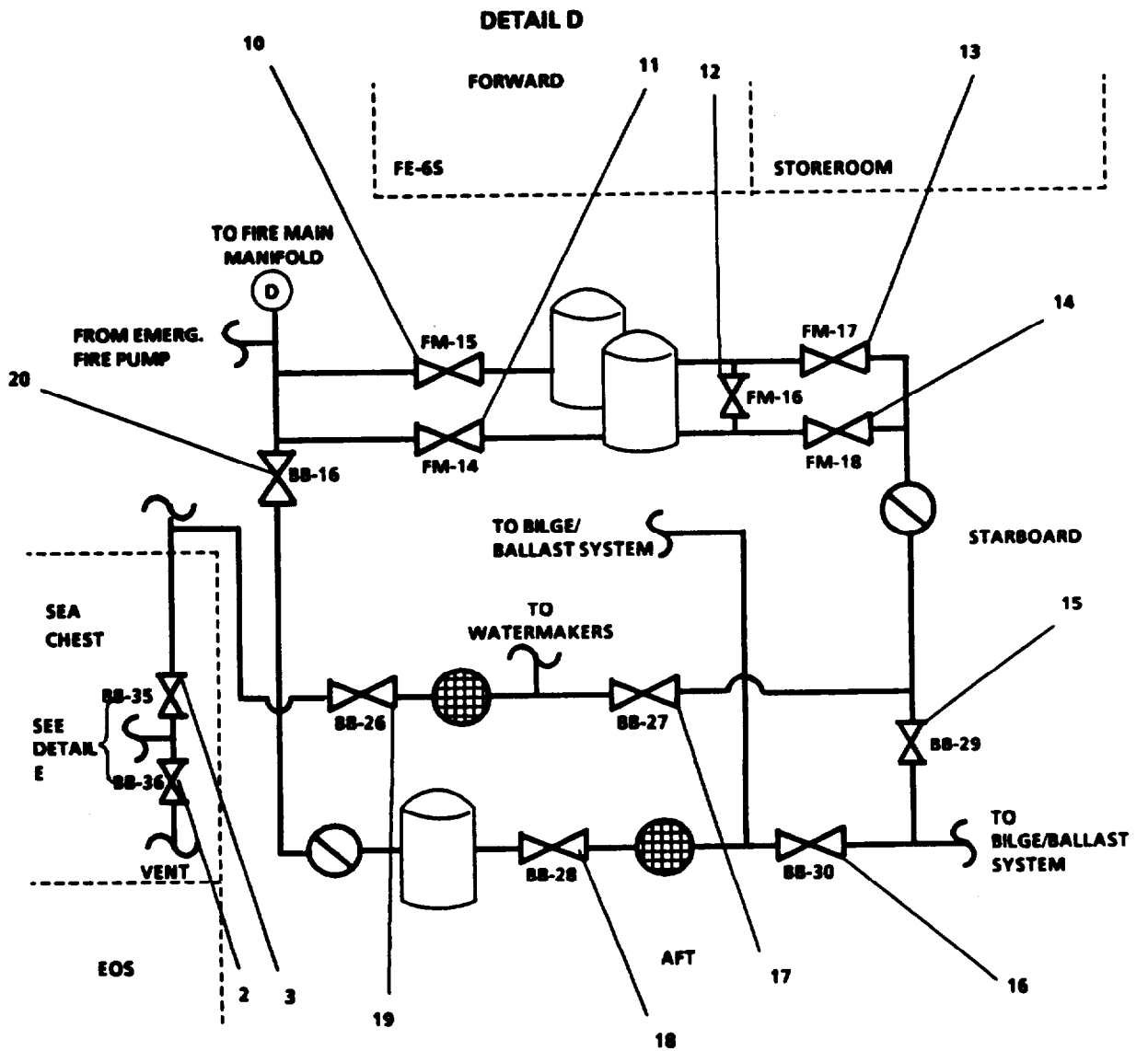
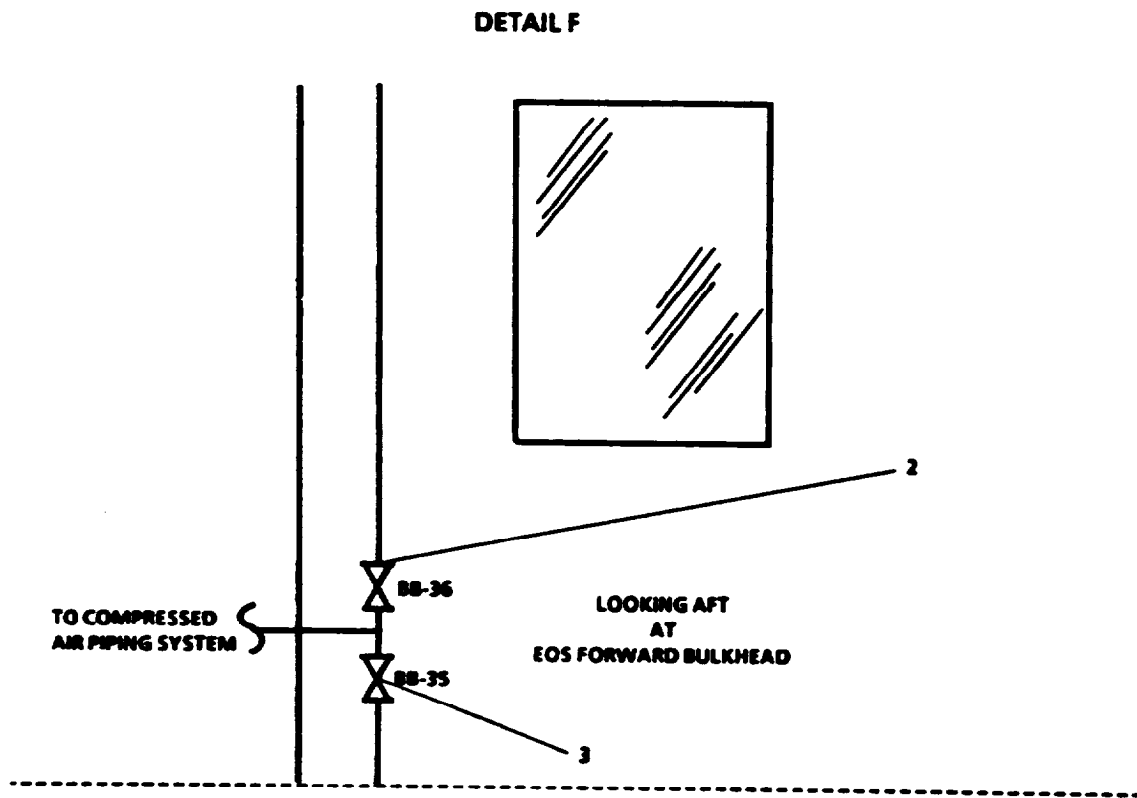


FIGURE 1-11. Fire Main and Foam Piping System (Sheet 4 of 8).



**FIGURE 1-11. Fire Main and Foam Piping System (Sheet 5 of 8).**

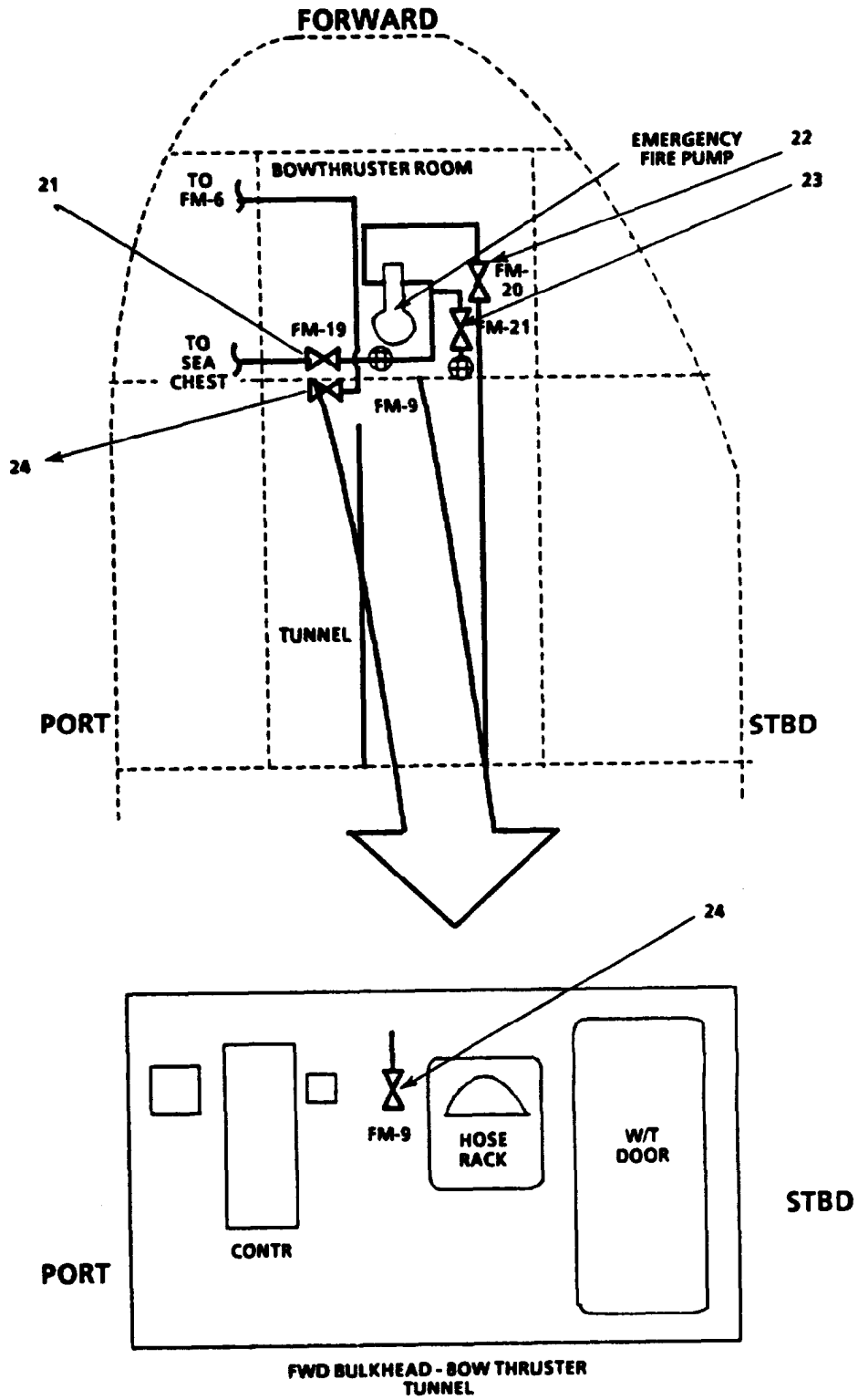


FIGURE 1-11 Fire Main and Foam Piping System (Sheet 6 of 8).

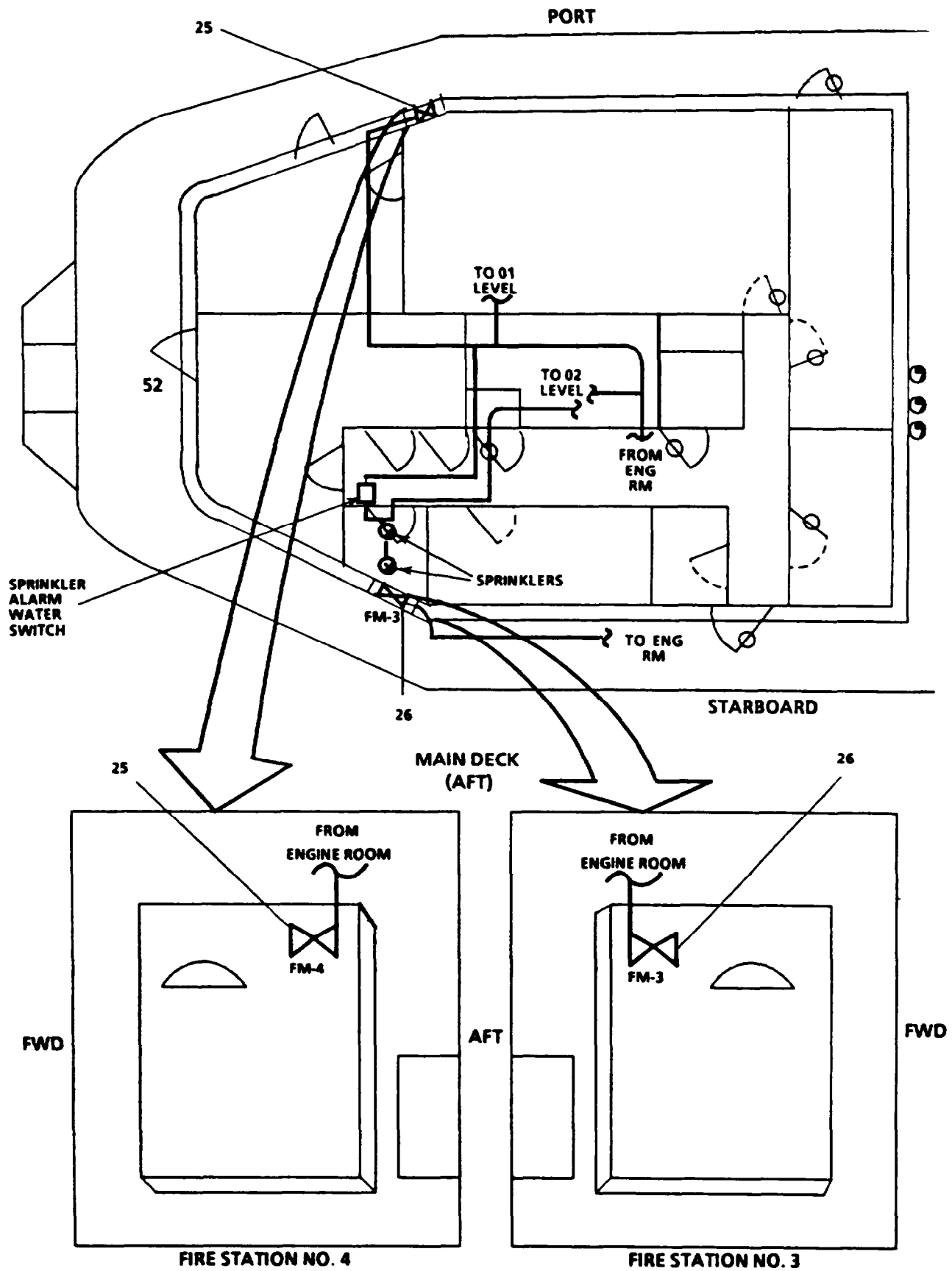


FIGURE 1-11. Fire Main and Foam Piping System (Sheet 7 of 8).



## LEGEND

1. FM-2, FIRE STA 2 ISLN
2. BB-36, SEA CHEST VENT VALVE
3. BB-35, SEA CHEST VENT ISOLATION
4. FM-1, FIRE STA 1 ISLN
5. FM-10, FIREMAIN ISLN
6. FM-22, CM WASHDOWN ISLN
7. EDUCTOR VALVE
8. FM-12, FOAM STA 1 & STBD MONITOR ISLN
9. FM-11, FOAM STA 2 & PORT MONITOR ISLN
10. FM-15, NO. 2 FIRE PUMP DISCH
11. FM-14, NO. 1 FIRE PUMP DISCH
12. FM-16, FIRE PUMP 1 & 2 SUCT CROSS CONN
13. FM-17, FIRE PUMP NO. 2 SUCT
14. FM-18, FIRE PUMP NO. 1 SUCT
15. BB-25, ISLN-SEA CHEST
16. BB-26, ISLN-STRAINER
17. BB-23, SEA CHEST
18. BB-24, SUCT-BILGE/BALLAST PUMP
19. BB-22, SEACHEST SUCT
20. BB-16, CROSS CONN TO FIREMAIN
21. FM-19, EMERG FIRE PUMP
22. FM-20, EMERG FIRE PUMP DISCH
23. FM-21, EMERG BILGE SUCT
24. FM-9, FIRE STA 9 ISLN
25. FM-4, FIRE STA 4 ISLN
26. FM-3, FIRE STA 3 ISLN
27. FM-6, FIRE STA 6 ISLN
28. FM-7, FIRE STA 7 ISLN
29. FM-8, FIRE STA 8 ISLN
30. ARMS ROOM SPRINKLER MANUAL ACTIVATION VALVE
31. FOAM-2, FOAM STA 2 ISLN
32. FM-24, PORT FOAM MONITOR ISLN
33. FM-23, STBD FOAM MONITOR ISLN

Figure 1-11. Fire Main and Foam Piping System (Sheet 8 of 8).

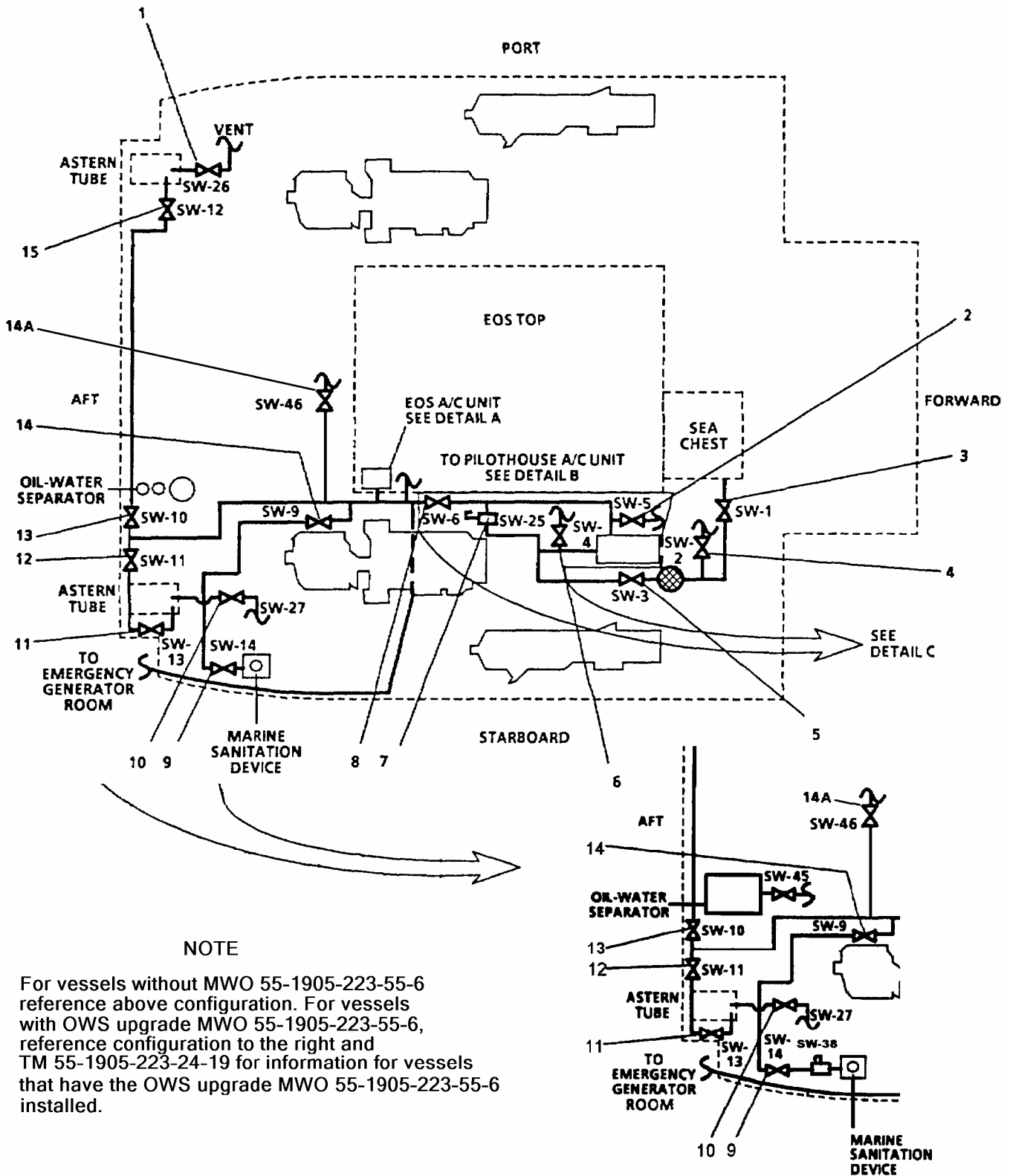


Figure 1-12. Seawater Cooling Piping System (Sheet 1 of 6).

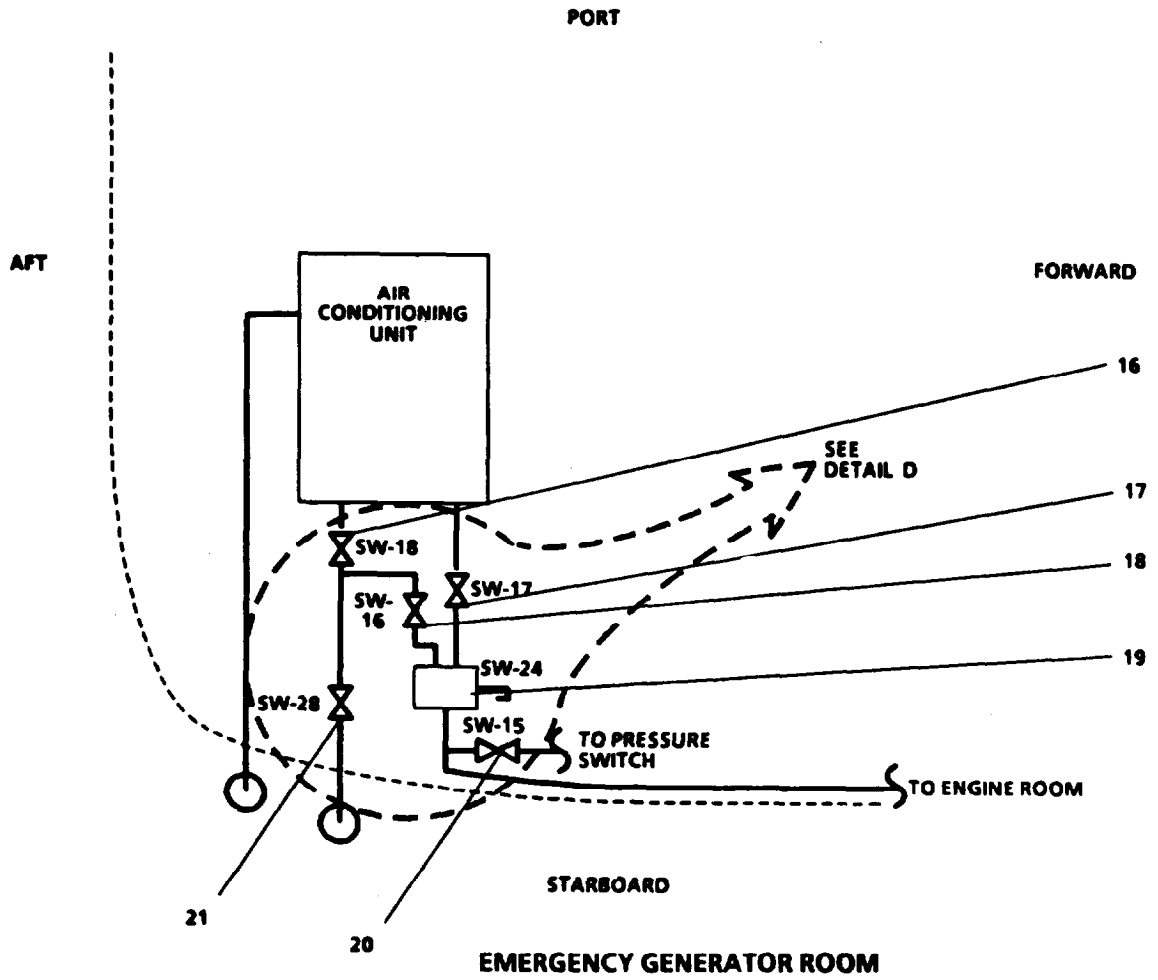


FIGURE 1-12. Seawater Cooling Piping System (Sheet 2 of 6).

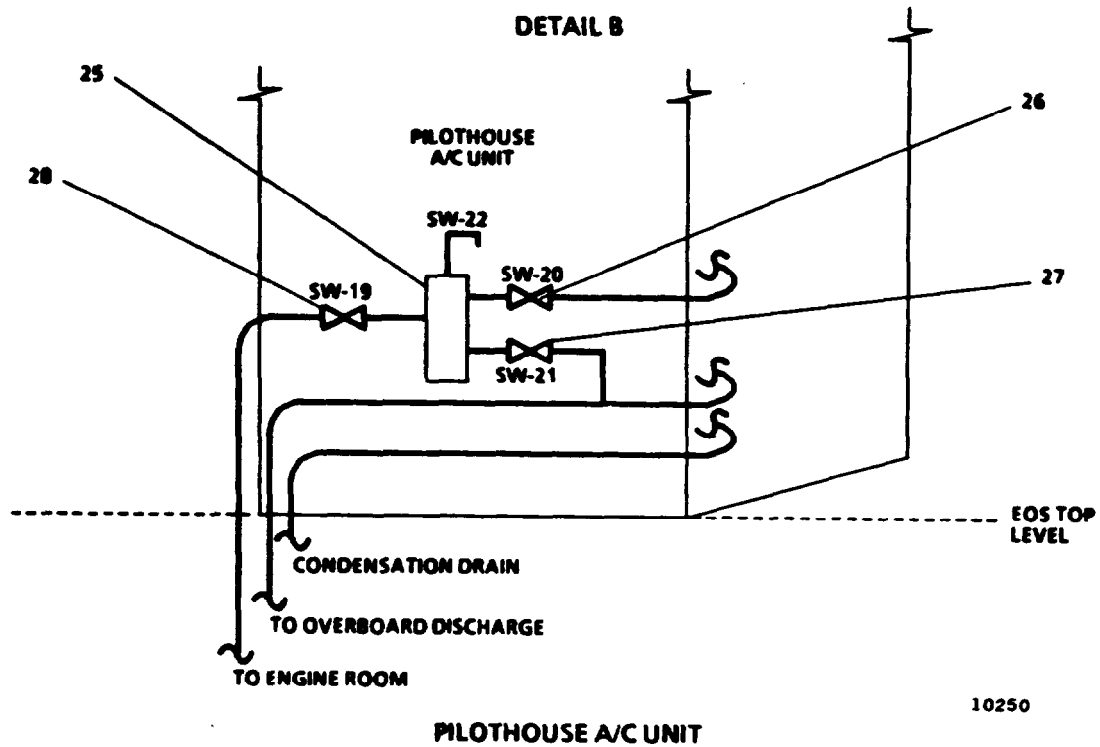
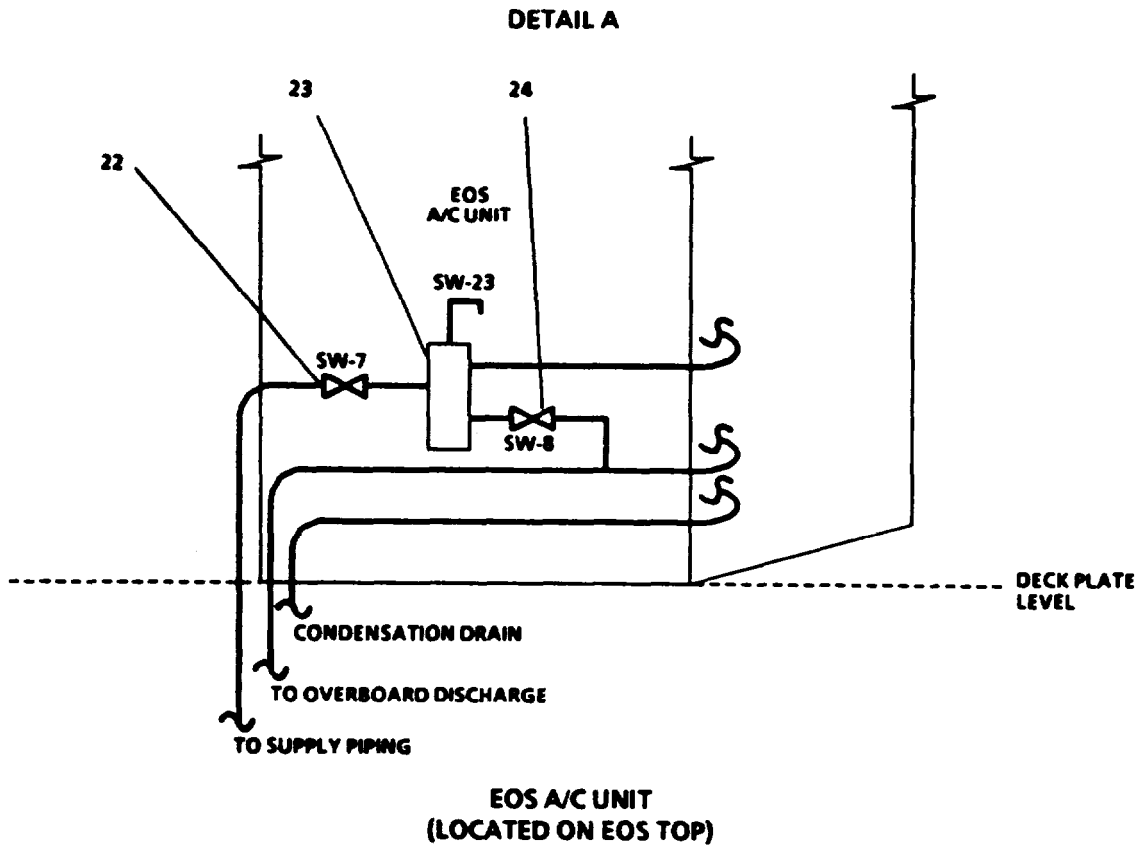


FIGURE 1-12. Seawater Cooling Piping System (Sheet 3 of 6).

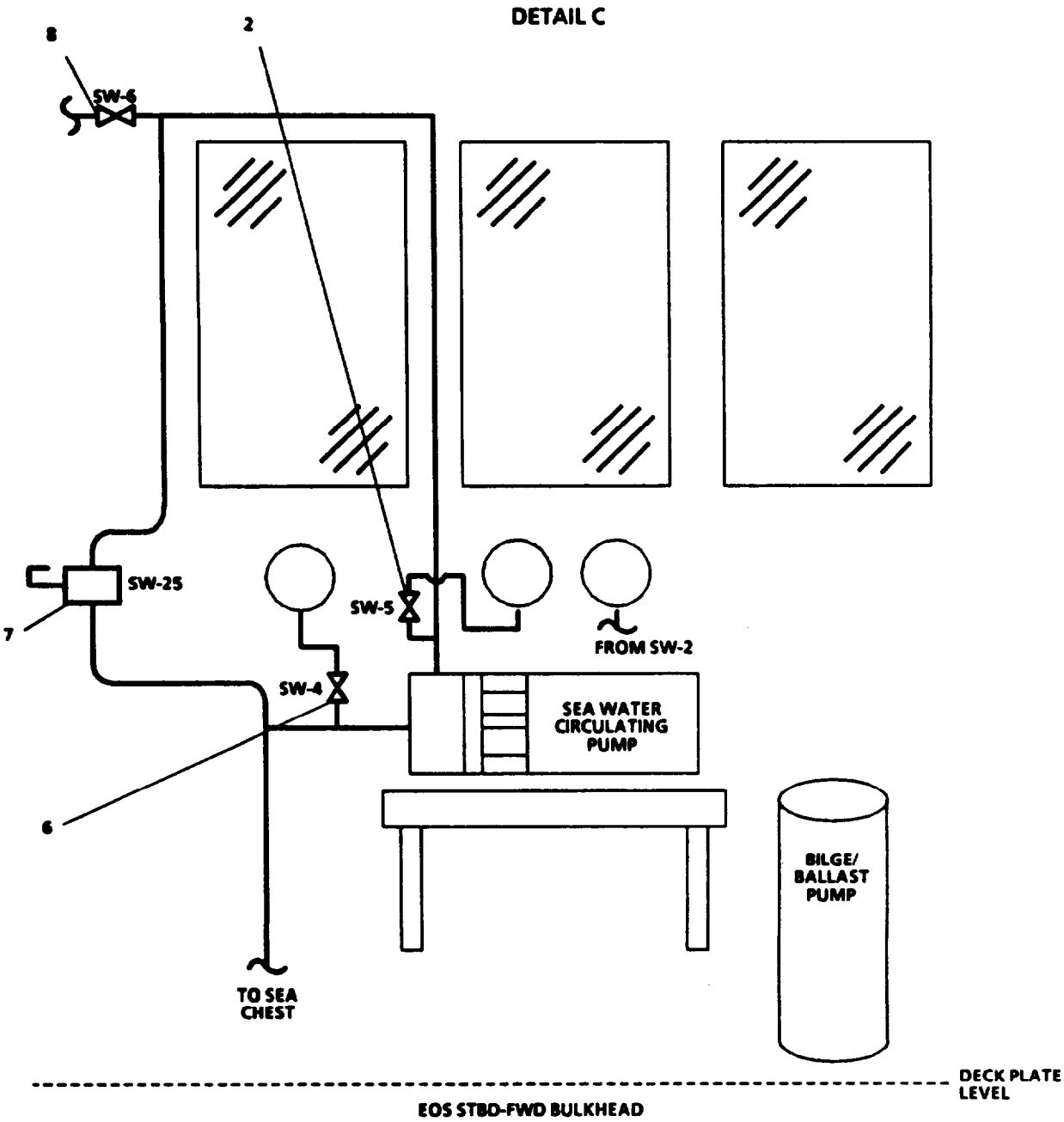


FIGURE 1-12. Seawater Cooling Piping System (Sheet 4 of 6).

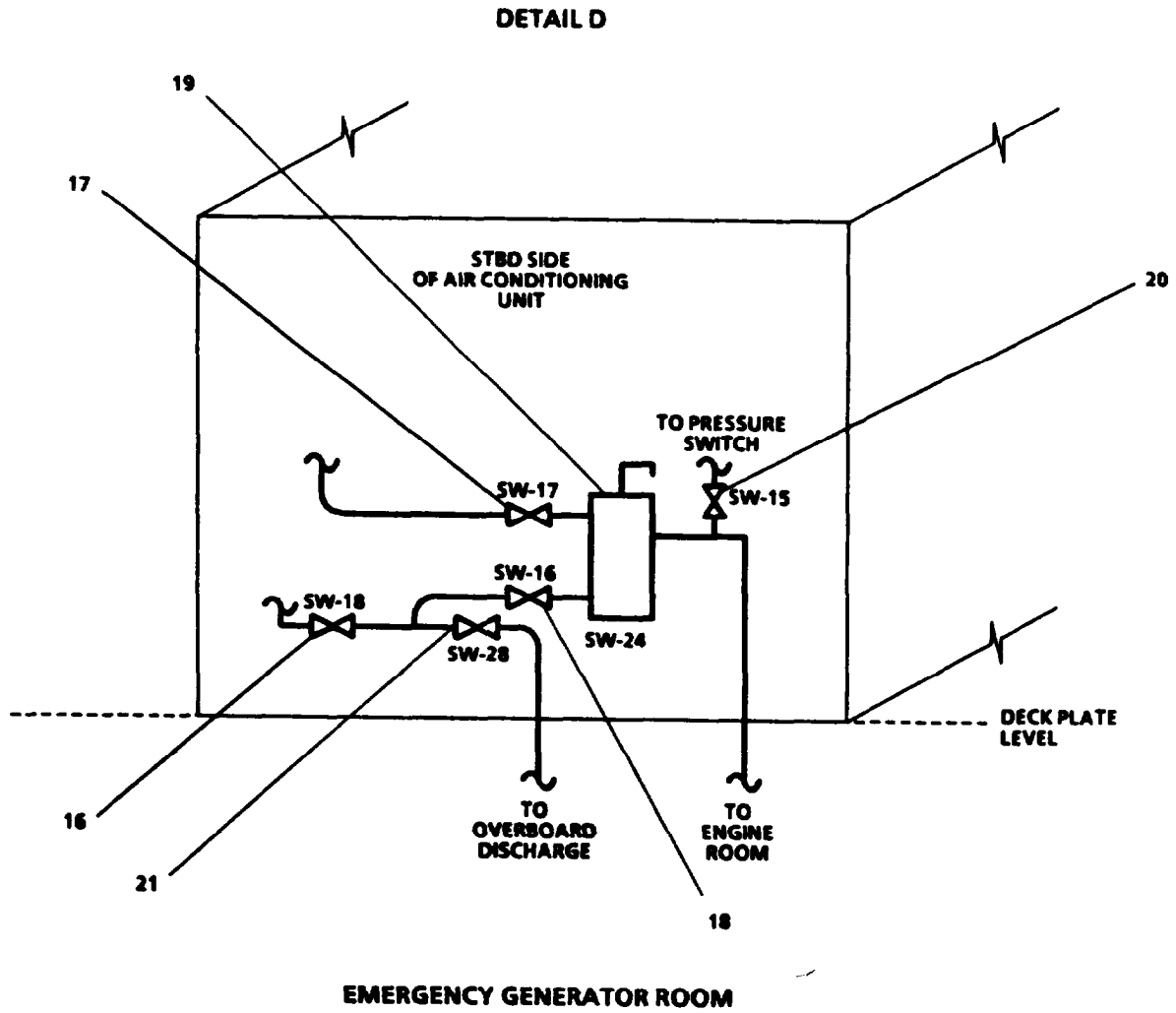
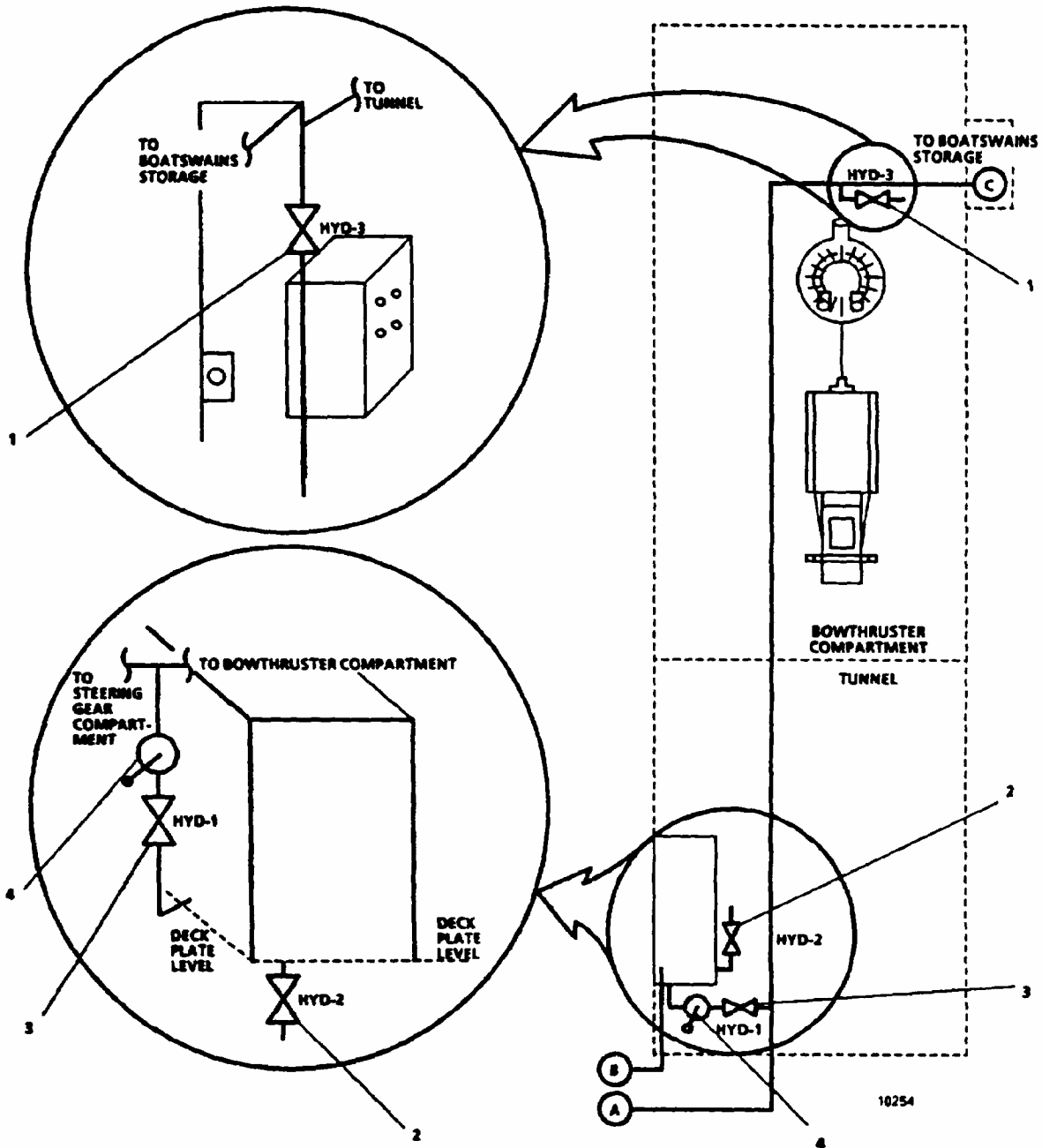


FIGURE 1-12. Seawater Cooling Piping System (Sheet 5 of 6).

## LEGEND

- |   |  |
|---|--|
| <ol style="list-style-type: none"> <li>1. SW-26, VENT-PORT STERN TUBE</li> <li>2. SW-5, PRESS GAGE PUMP DISCH</li> <li>3. SW-1, SUPPLY TO PUMP</li> <li>4. SW-2, PRESS GAGE SUPPLY TO STRAINER</li> <li>5. SW-3, PUMP SUCTION</li> <li>6. SW-4, PRESS GAGE PUMP SUCTION</li> <li>7. SW-25, RELIEF VALVE SET AT 55 PSI</li> <li>8. SW-6, PUMP DISCH</li> <li>9. SW-14, ISOLATION-MSD</li> <li>10. SW-27, VENT-STBD STERN TUBE</li> <li>11. SW-13, ISLN-STBD STERN TUBE</li> <li>12. SW-11, SUPPLY TO STBD STERN TUBE</li> <li>13. SW-10, SUPPLY TO PORT STERN TUBE</li> <li>14. SW-9, SUPPLY TO MSD</li> </ol> | <ol style="list-style-type: none"> <li>14A. SW-46, FIREMAIN/ASW CROSS CONNECT</li> <li>15. SW-12, ISLN-PORT STERN TUBE</li> <li>16. SW-18, DISCH FROM AIR COND UNIT</li> <li>17. SW-17, SUPPLY TO AIR COND UNIT</li> <li>18. SW-16, BY-PASS</li> <li>19. SW-24, REGULATING VALVE</li> <li>20. SW-15, SUPPLY TO PRESS SWITCH</li> <li>21. SW-28, OVBD DISCH FR AIR COND UNIT</li> <li>22. SW-8, BY-PASS</li> <li>23. SW-23, REGULATING VALVE</li> <li>24. SW-7, SUPPLY TO AIR COND UNIT</li> <li>25. SW-22, REGULATING VALVE</li> <li>26. SW-20, ISLN TO AIR COND UNIT</li> <li>27. SW-21, BY-PASS</li> <li>28. SW-19, SUPPLY TO AIR COND UNIT</li> </ol> |
|---|--|

Figure 1-12. Seawater Cooling Piping System (Sheet 6 of 6).

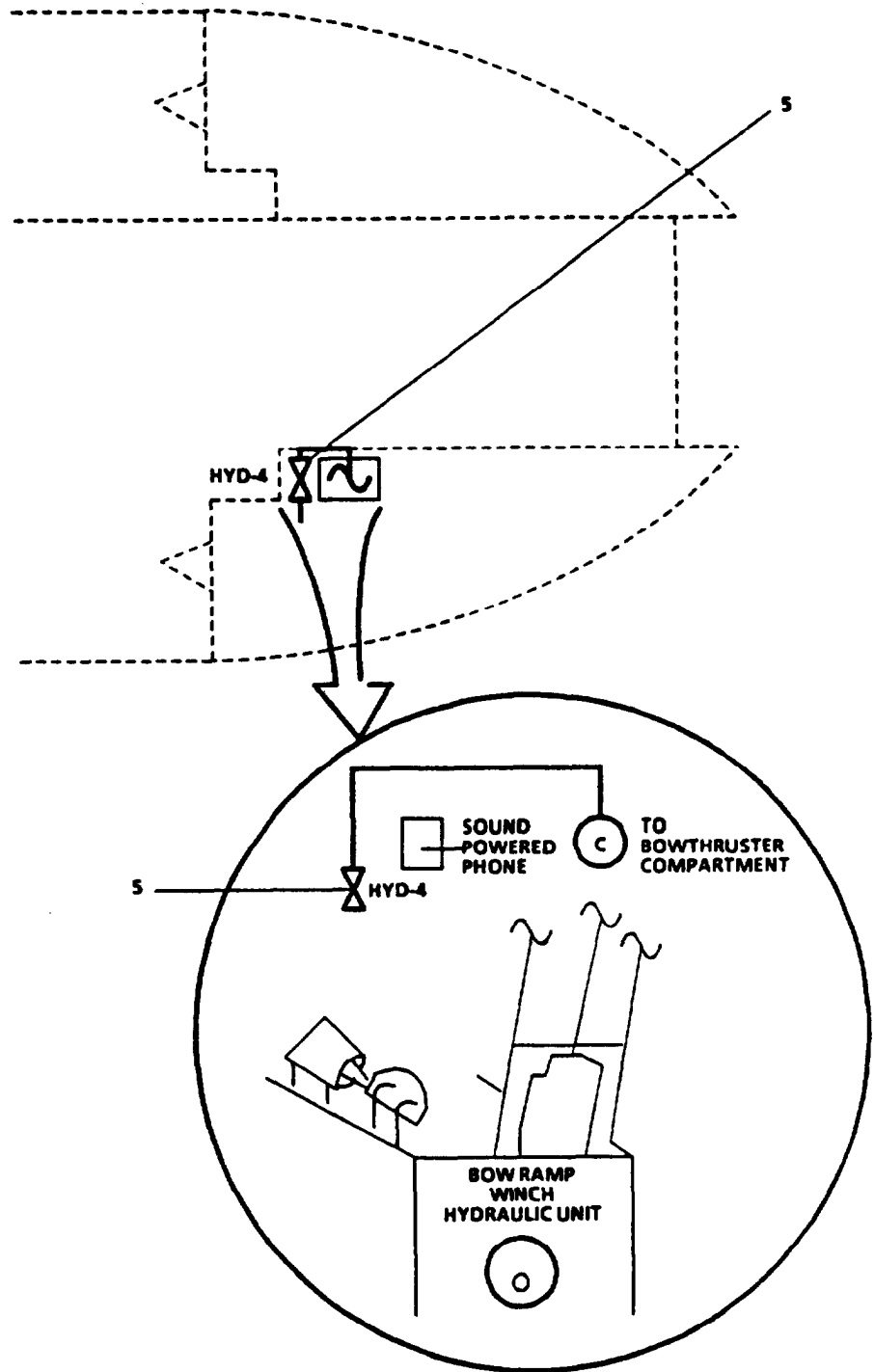


**LEGEND**

- 1. HYD-3, PWR PACK FILL
- 2. HYD-2, STORAGE TK DRAIN
- 3. HYD-1, HAND PUMP SUCT-STOR TK
- 4. HYD OIL HAND PUMP

Figure 1-13. Hydraulic Oil Supply System (Sheet 1 of 3).





**LEGEND:**  
5. HYD-4, PWR PACK FILL

FIGURE 1-13. Hydraulic Oil Supply Piping System (Sheet 2 of 3).

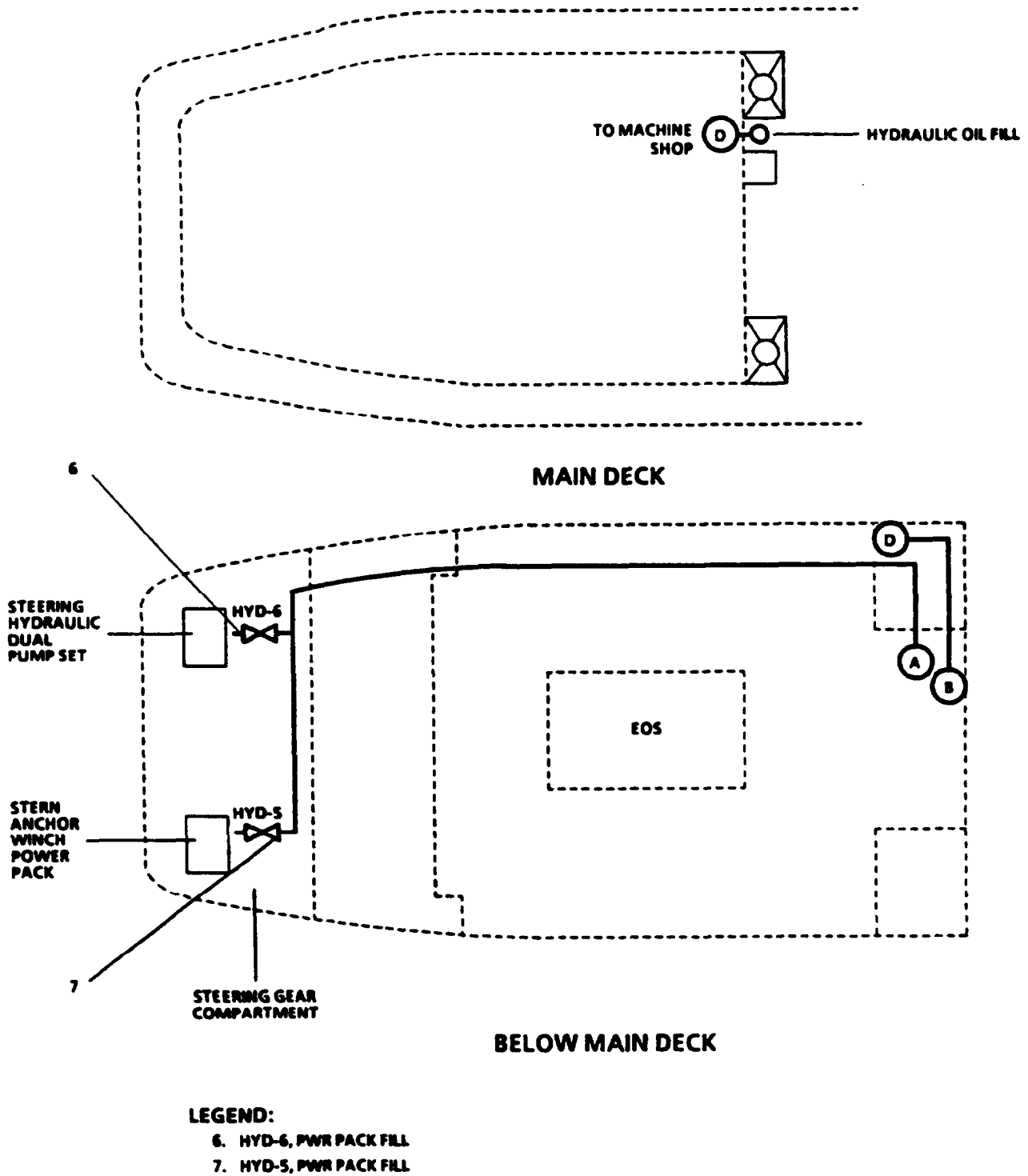


FIGURE 1-13. Hydraulic Oil Supply Piping System (Sheet 3 of 3).

**1-26. Fuel Oil Transfer Piping System.** The fuel oil transfer piping system replenishes the ship's fuel oil tanks from deck discharge/fill connections and replenishes engine and generator day tanks by transferring fuel oil from storage tanks. System control is maintained through a combination of valves as shown in FIGURE 1-14. Fuel oil can be transferred between any storage tank and day tank. No. 1 fuel oil transfer pump is supplied power from the auxiliary machinery motor control center and controlled by a START/STOP pushbutton and an emergency STOP switch at the pump. No. 2 fuel oil transfer pump is supplied power from the emergency switchboard 240 Vac distribution and controlled by a START/STOP pushbutton and an emergency stop pushbutton. Each pump has a run indicator lamp on the engine room operating station console.

#### NOTE

**Halon pressure switch is not applicable to vessels with FM-200 Fire Suppressant System installed. Reference TM 55-1905-243-24&P, LCU-2000, FM-200 Fire Fighting System for maintenance and installation of FM-200 components.**

Each pump also will be shut down upon any HALON pressure switch activation. Fuel oil purification is provided by the fuel oil filter/separator. Included in the fuel oil transfer piping system is dual fuel filters for each main engine. In an emergency, fuel may be transferred by the hand pump.

**1-27. Compressed Air Piping System.** The compressed air piping system delivers the air pressure required for starting the main engines, No. 2 SSDG (port), and other uses. System control is maintained through a combination of valves as shown in FIGURE 1-15. The compressed air piping system consists of two compressors that deliver compressed air to two 200-gallon air receivers at 200 pounds per square inch (psi) pressure. This air passes through a reducing valve, reducing the pressure to control air pressure of 125 psi, moisture separator, and an automatic dryer to points of usage. Supply air is furnished to sea chest blow down. Service air is supplied to the machine shop, bow thruster room, and above deck points. Control air is supplied to the dual throttle control system. Air pressure is controlled from individual compressor pressure switches. Compressor power is supplied by the auxiliary machinery motor control center with pushbutton START/STOP stations located at each compressor. Each compressor has a run indicator lamp on the engine room control console.

**1-28. Lubricating Oil Transfer and Piping System.** The lubricating oil transfer and piping system supplies clean lubricating oil for proper operation of the main propulsion engines. The system also transfers lubricating oil from the storage tank to the main engines and ships service diesel generator engines sumps. The system also draws lubricating oil, from the main engines sumps. Pre-lubricating the main engines after an extended shutdown period is possible with use of the pre-lube pump. The system can be aligned to transfer dirty lubricating oil from the main, SSDG, and bow thruster engines and reverse reduction gearboxes to the dirty oil tank. System alignment is maintained by a combination of valves and hand pumps as shown in FIGURE 1-16. Dirty oil and sludge are discharged from the system via the dirty oil pump to port or starboard dirty oil discharge deck connections. Power for the lube oil pre-lube pump, and dirty oil pump is supplied by the auxiliary machinery motor control center. Each has a START/STOP pushbutton adjacent to the unit and run indicator lamps on the engine room operating station engine room console panel. Containers for replenishing lubricating oil at the bow thruster engine, main reduction gears, and emergency generator diesel engine, may be filled at the storage tank container fill valve.

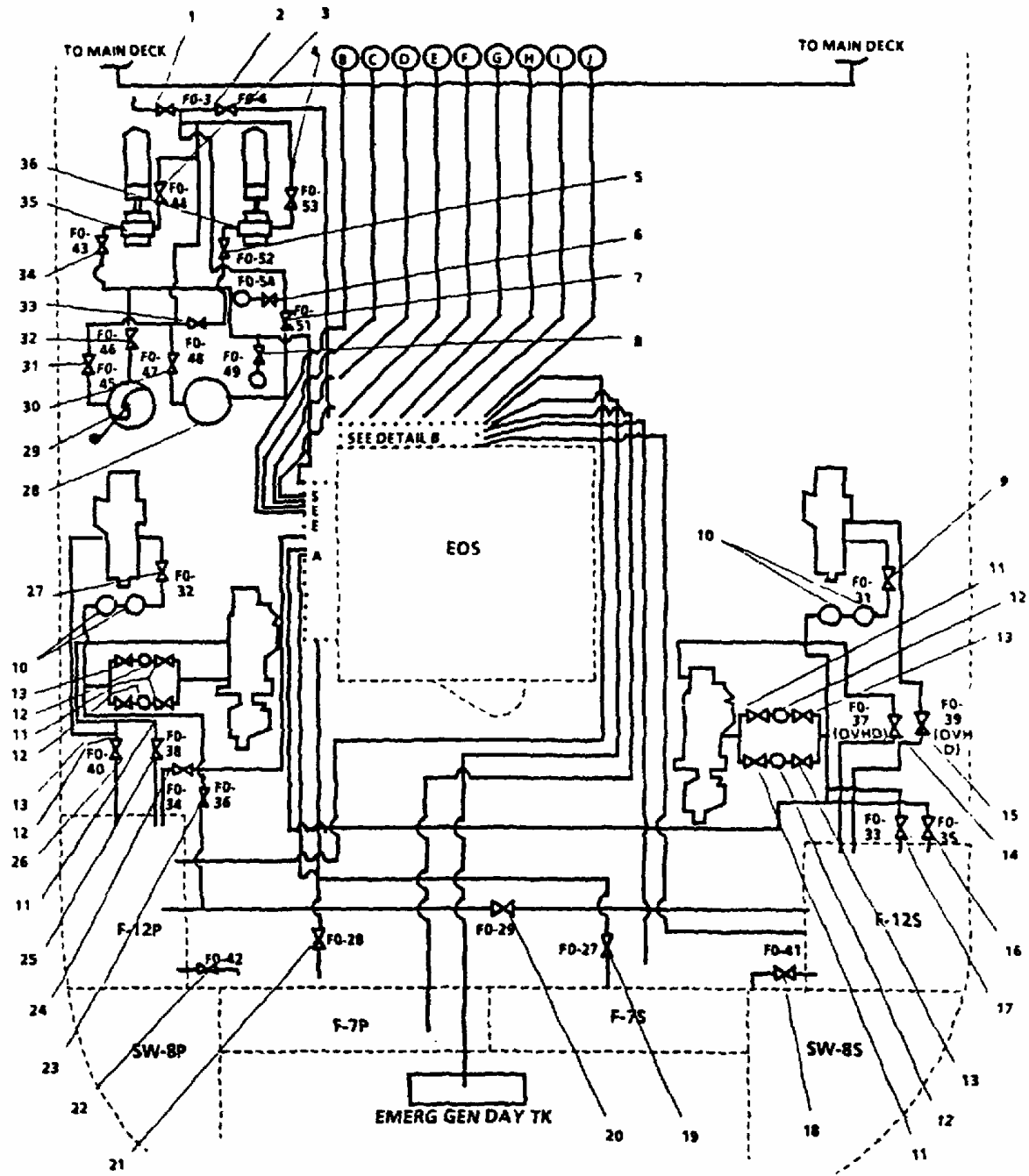


Figure 1-14. Fuel Oil Filter, Transfer and Supply Piping System (Sheet 1 of 5).

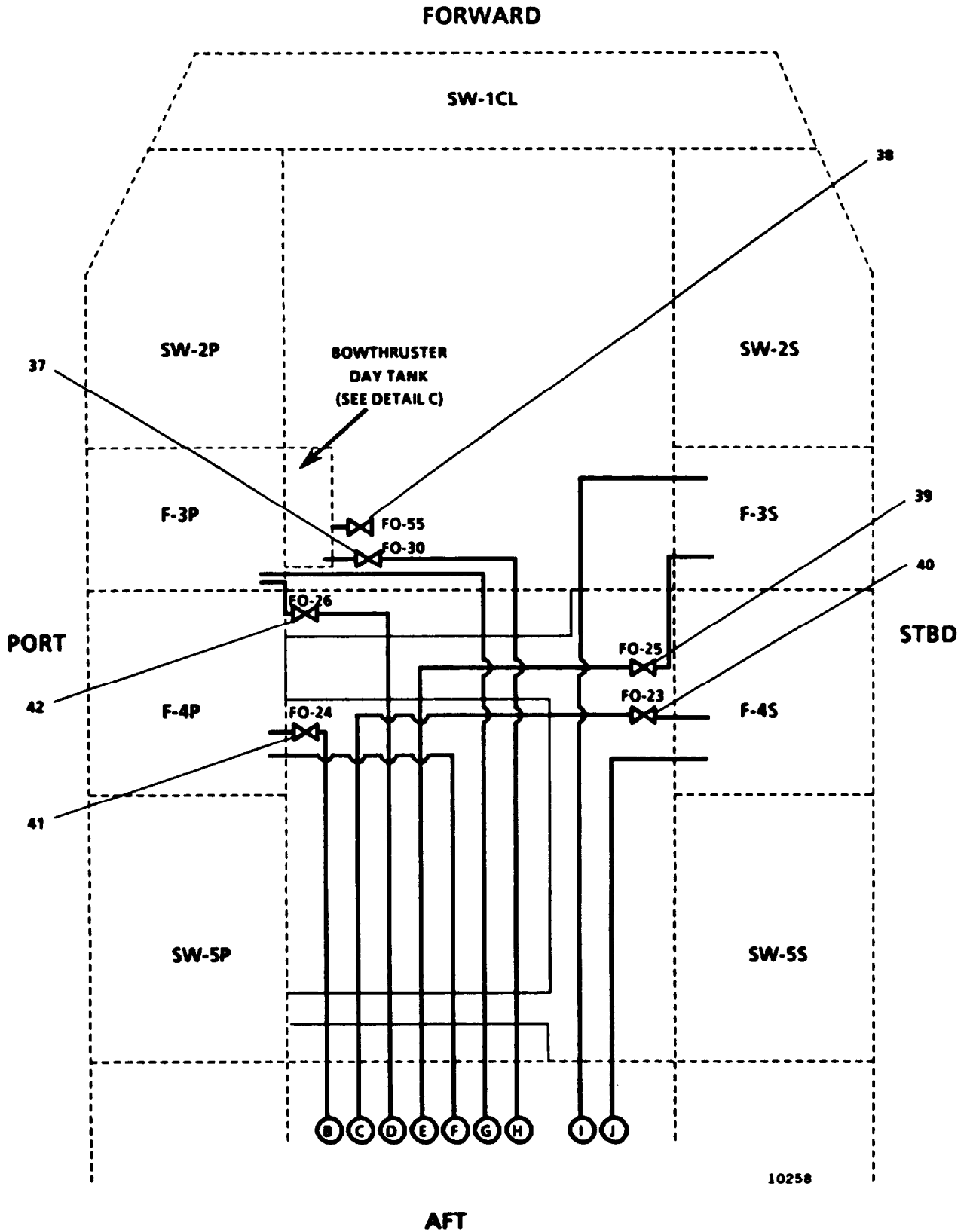


FIGURE 1-14. Fuel Oil Filter, Transfer, and Supply Piping System (Sheet 2 of 5).

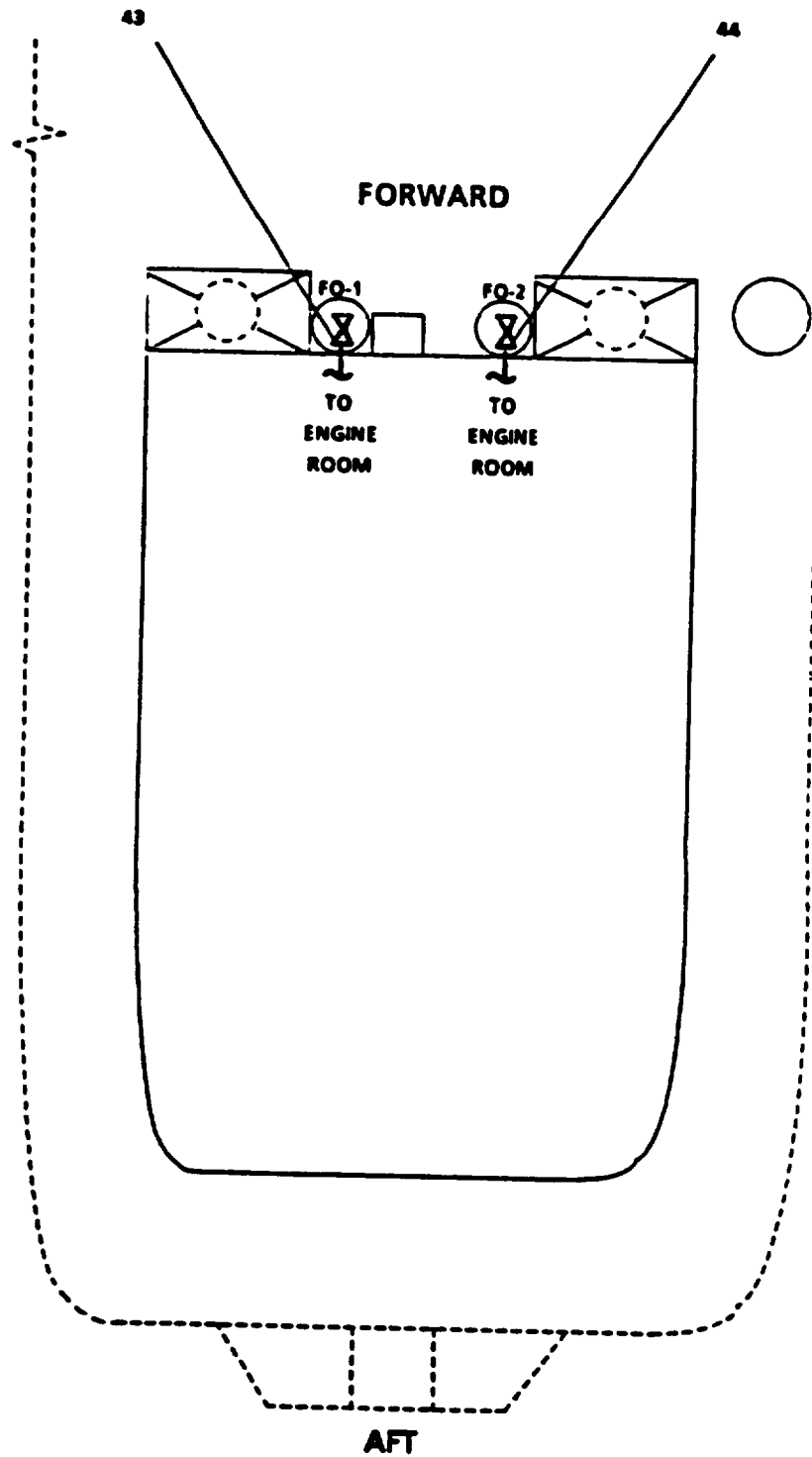


FIGURE 1-14. Fuel Oil Filter, Transfer, and Supply Piping System (Sheet 3 of 5).

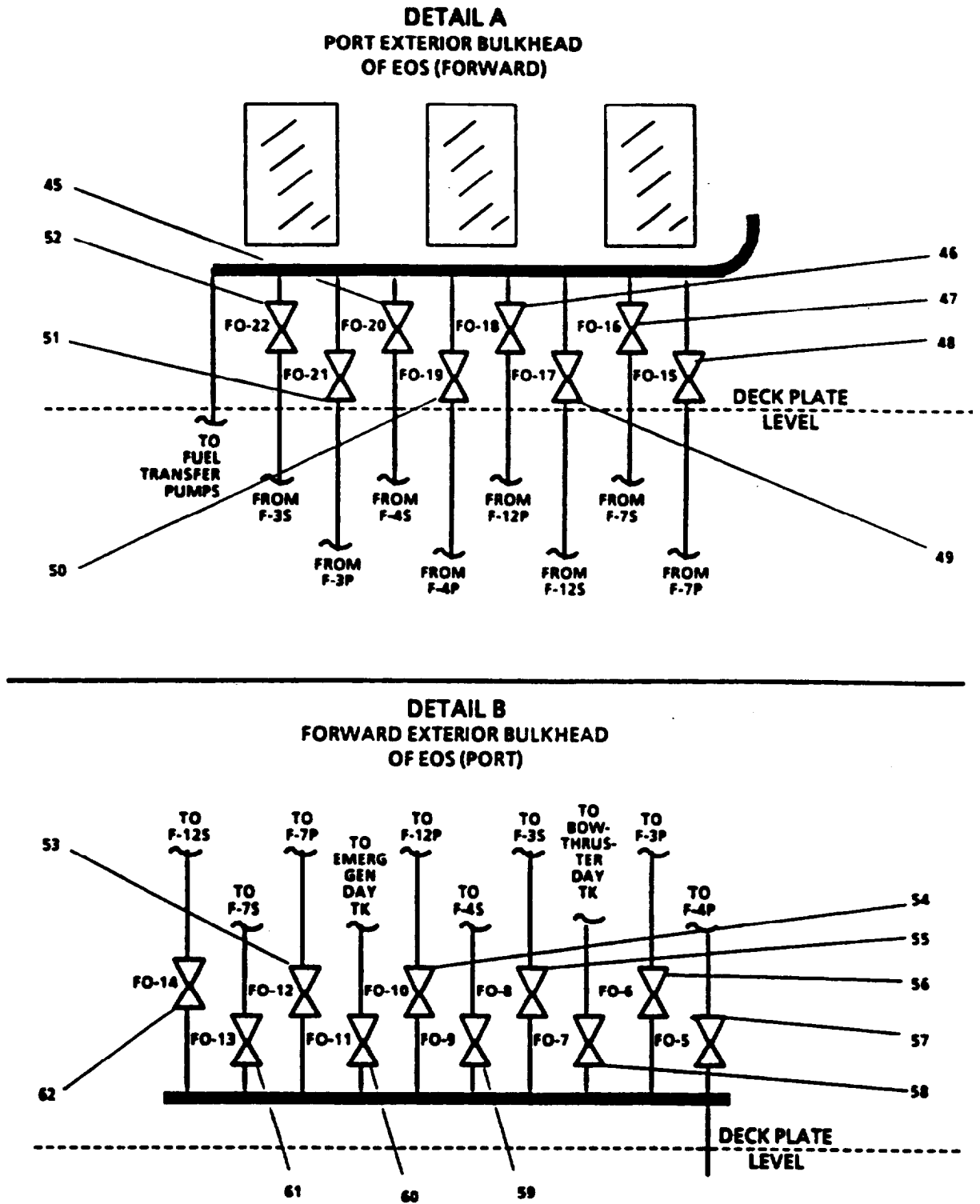


FIGURE 1-14. Fuel Oil Filter, Transfer, and Supply Piping System (Sheet 4 of 5).

LEGEND

- |   |   |
|---|---|
| 1. FO-3. ISLN. FILL/DISCH STATIONS                  | 33. FO-48, BY-PASS FILTER/SEPARATOR     |
| 2. FO-4, SUPPLY TO FO SUPPLY MANF                   | 34. FO-43, SUCT-NO. 2 XFR PUMP          |
| 3. FO-44, DISCH -NO. 2 XFR PUMP                     | 35. NO. 2 XFR PUMP                      |
| 4. FO-53, DISCH- NO. 1 XFR PUMP                     | 36. NO. 1 XFR PUMP)                     |
| 5. FO-52, SUCT-NO. 1 XFR PUMP                       | 37. FO-30. SUPPLY TO BOWTHRUSTER DAY TK |
| 6. FO-54. PUMP DISCH PRESS GAGE                     | 38. FO-55, SUPPLY TO BOWTHRUSTER ENGINE |
| 7. FO-51. FILTER/SEPARATOR OUTLET                   | 39. FO-25, SUCT FR TKF-35               |
| 8. FO-49. PUMP SUCT PRESS GAGE                      | 40. FO-23, SUCT FR TKF-45               |
| 9. FO-31. SUPPLY TO STBD SSDG                       | 41. FO-24, SUCT FR TKF-4P               |
| 10. SSDG FUEL FILTERS                               | 42. FO-26, SUCT FR TKF-3P               |
| 11. MN ENG FILTER DISCH VALVE                       | 43. FO-1, FUEL OIL FILL/DISCH           |
| 12. MN ENG FILTER                                   | 44. FO-2, FUEL OIL FILL/DISCH           |
| 13. MN ENG FILTER INLET VALVE                       | 45. FO-20, SUCT FR TK F-45              |
| 14. FO-39. RETURN FR STBD SSDG TO DAY TN F-12S      | 46. FO-18. SUCT FR TKF-12P              |
| 15. FO-37, RETURN FR STBD MN ENG TO DAY TKF-125     | 47. FO-16, SUCT FR TKF-75               |
| 16. FO-35. SUCT FR DAY TKF-12S                      | 48. FO-15. SUCT FR TKF-7P               |
| 17. FO-33, DAY TKF-125 SUPPLY TO STBD MN ENG & SSDG | 49. FO-17, SUCT FR TKF-125              |
| 18. FO-41, DRAIN FR DAY TKF F-125                   | 50. FO-19. SUCT FR TKF-4P               |
| 19. FO-27. SUCT FR TKF-7S                           | 51. FO-21, SUCT FR TKF-3P               |
| 20. FO-29. CROSS CONN -DAY TKS                      | 52. FO-22, SUCT FR TKF-35               |
| 21. FO-28, SUCT FR TK F-7P                          | 53. FO-12, SUPPLY TO TKF-7P             |
| 22. FO-42. DRAIN FR DAY TKF-12P                     | 54. FO-10, SUPPLY TODAY TKF-12P         |
| 23. FO-36, DAY TKF-12P SUPPLY TO PORT MN ENG & SSDG | 55. FO-8, SUPPLY TO TKF-35              |
| 24. FO-34. SUCT FR DAY TK F-12)                     | 56. FO-6, SUPPLY TO TN F-3P             |
| 25. FO-38. RETURN FR PORT MN ENG TO DAY TKF-12P     | 57. FO-5, SUPPLY TO TKF-4P              |
| 26. FO-40, RETURN FR PORT SSDG TO DAY TKF-12P       | 58. FO-7, SUPPLY TO BOWTHRUSTER DAY TK  |
| 27. FO-32, SUPPLY TO PORT SSDG                      | 59. FO-9, SUPPLY TO TKF-45              |
| 28. FUEL FILTER/COALESCER                           | 60. FO-11, SUPPLY TO EMER GEN DAY TK    |
| 29. FUEL TRANSFER HAND PUMP                         | 61. FO-14, SUPPLY TO TK-75              |
| 30. FO-47, FILTER/SEPERATOR INLET                   | 62. FO-14, SUPPLY TO TK-125             |
| 31. FO-45, HAND PUMP DISCH                          | 63. BOWTHRUSTER DAY TK DRAIN            |
| 32. FO-46. HAND PUMP SUCT                           |   |

**FIGURE 1-14. Fuel Oil Filter, Transfer, and Supply Piping System (Sheet 5 of 5).**



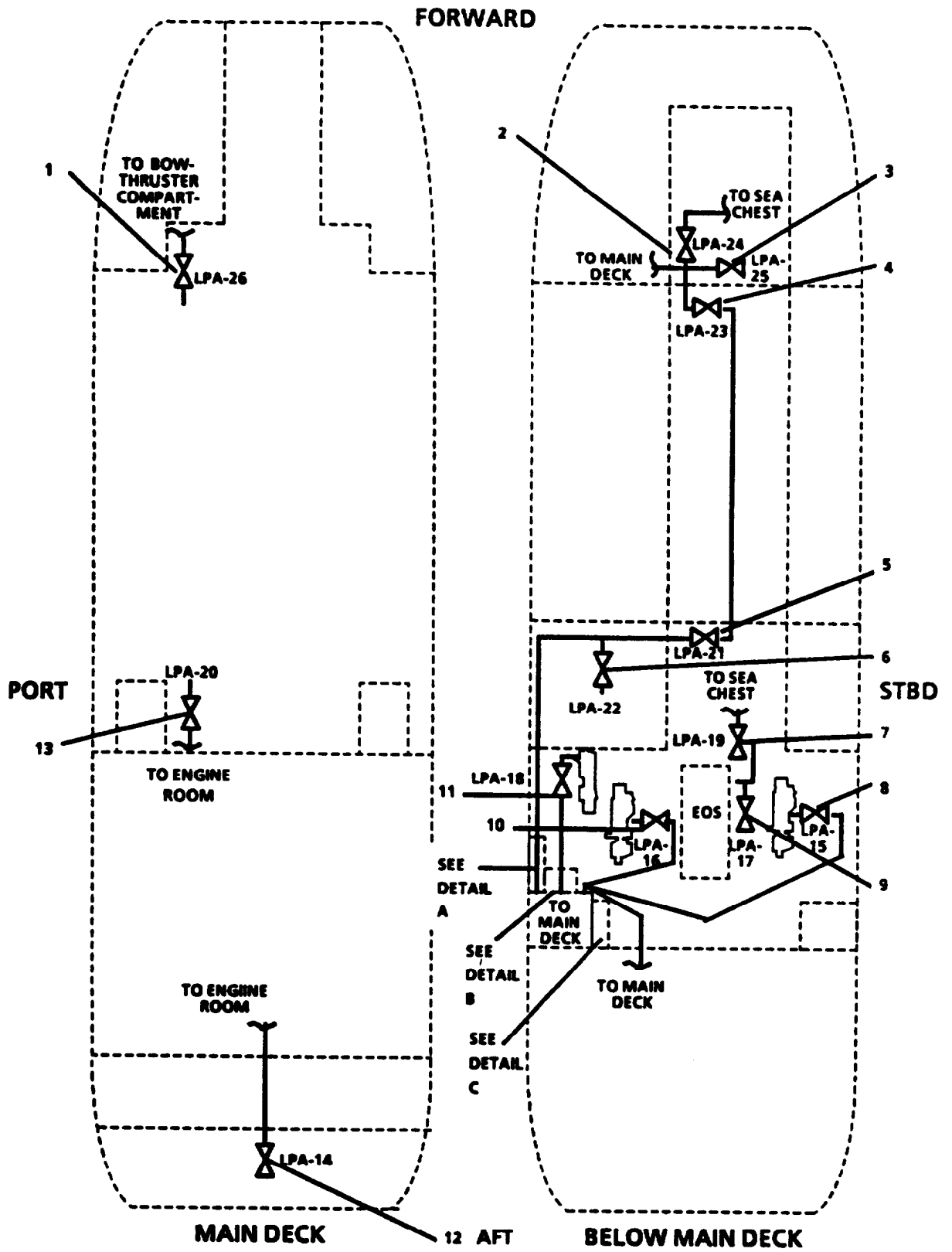


FIGURE 1-15. Compressed Air Piping (Sheet 1 of 5)

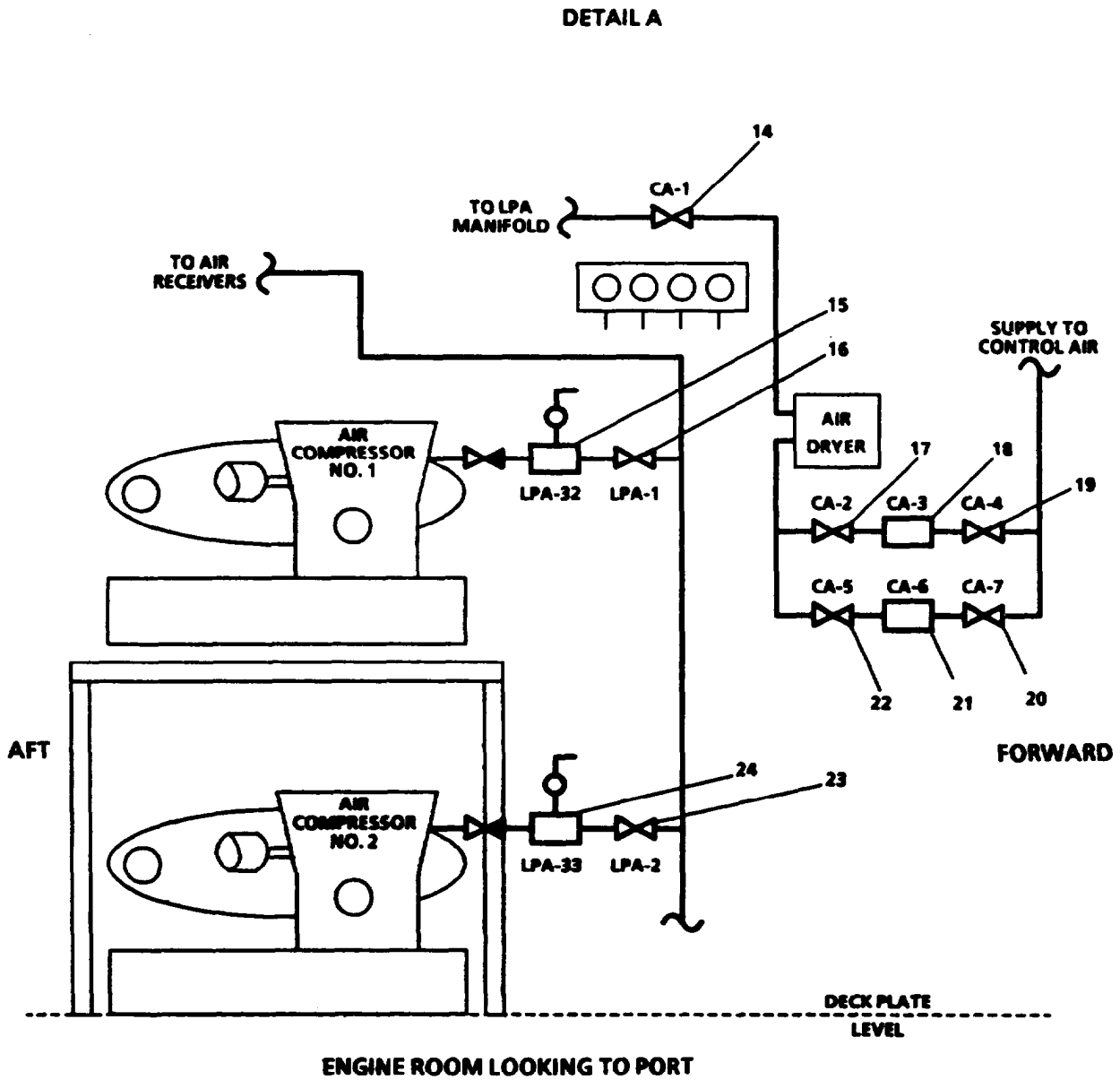


FIGURE 1-15. Compressed Air Piping System (Sheet 2 of 5)

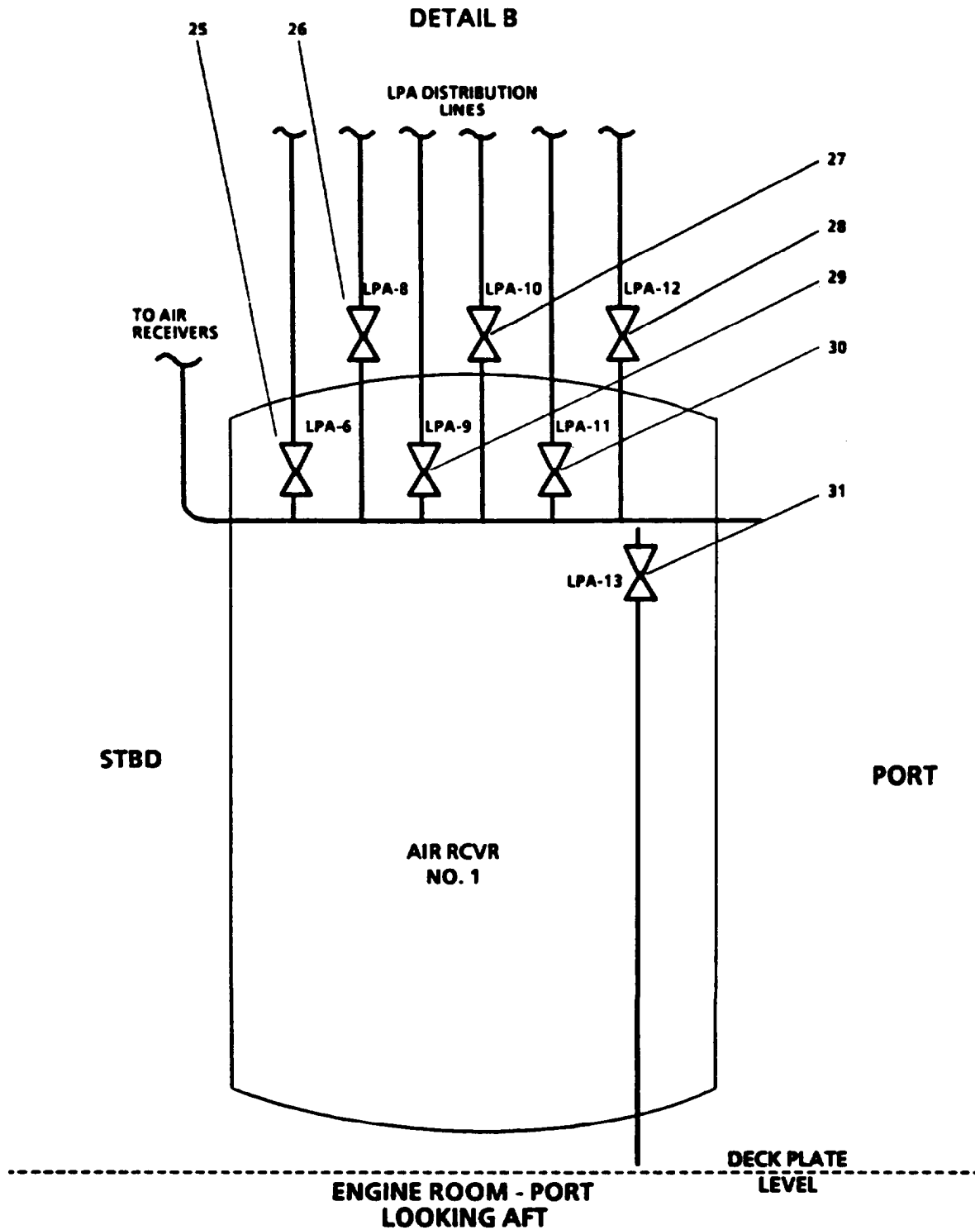


FIGURE 1-15. Compressed Air Piping System (Sheet 3 of 5).

DETAIL C

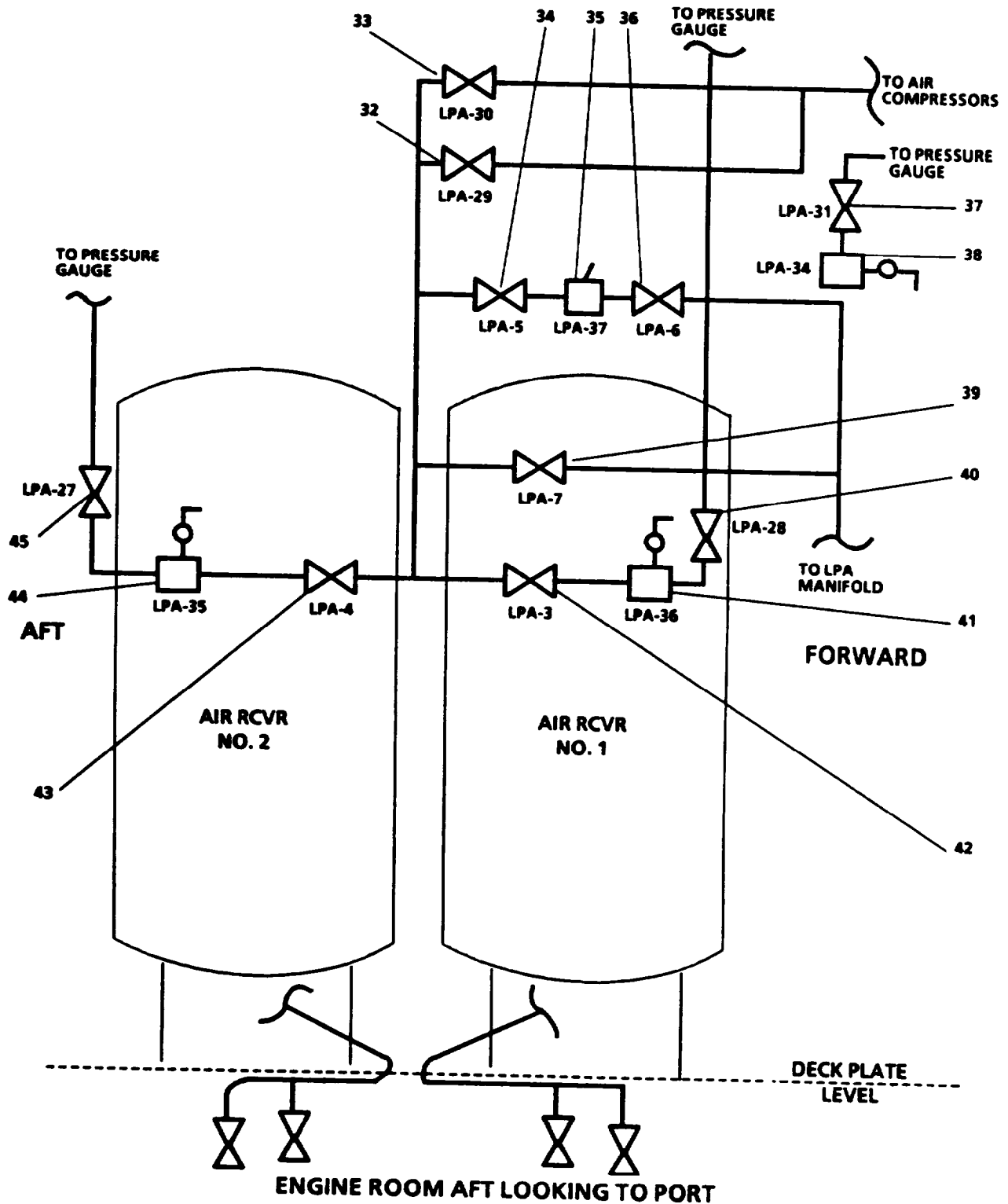


FIGURE 1-15. Compressed Air Piping System (Sheet 4 of 5).

## LEGEND

- |  |  |
|--|--|
| 1. LPA-26, SUPPLY TO SVCE AIR          | 24. LPA-33, RELIEF VLV-AIR CPRSR NO. 2 |
| 2. LPA-24, SEA CHEST BLWDN             | 25. LPA-6, SUPPLY TO MANF              |
| 3. LPA-25, SUPPLY TO SVCE AIR          | 26. LPA-8, SUPPLY TO CONTROL AIR       |
| 4. LPA-23, SUPPLY TO FWD SVCE AIR      | 27. LPA-10, SUPPLY TO MN ENG-STBD      |
| 5. LPA-21, SUPPLY TO FWD SVCE AIR      | 28. LPA-12, SUPPLY TO SSDG-PORT        |
| 6. WA-22, SUPPLY TO SVCE AIR           | 29. LPA-9, SUPPLY TO SVCE AIR          |
| 7. LPA-19, SEA CHEST BLWDN             | 30. LPA-11, SUPPLY TO MN ENG-STBD      |
| 8. LPA-15, SUPPLY TO MN ENG-STBD       | 31. LPA-13, MANIFOLD DRAIN             |
| 9. LPA-17, SUPPLY TO SVCE AIR          | 32. LPA-29, TO AIR CPRSR UNLOADERS     |
| 10. LPA-16, SUPPLY TO ENG-PORT         | 33. LPA-30, PRESS SW                   |
| 11. LPA-18, SUPPLY TO SSDG-PORT        | 34. LPA-5, SUPPLY TO PRESS RDCR        |
| 12. LPA-14, SUPPLY TO SVCE AIR         | 35. LPA-37, PRESS RDCR                 |
| 13. LPA-20, SUPPLY TO SVCE AIR         | 36. LPA-6, SUPPLY TO MANIF             |
| 14. CA-1, CONTROL AIR CUTOUT           | 37. LPA-31, PRESS GAGE                 |
| 15. LPA-32, RELIEF VLV-AIR CPRSR NO. 1 | 38. LPA-34, RELIEF VLV                 |
| 16. LPA-1, DISCH-AIR CPRSR NO. 1       | 39. LPA-7, BYPASS TO MANF              |
| 17. CA-2, ISLN-SEP/RGLTR               | 40. LPA-28, PRESS GAGE-AIR RCVR NO. 1  |
| 18. CA-3, SEP/RGLTR                    | 41. LPA-36, RELIEF VLV-AIR RCVR NO. 1  |
| 19. CA-4, SUPPLY TO CONTROL AIR        | 42. LPA-3, ISLN-AIR RCVR NO. 1         |
| 20. CA-7, SUPPLY TO CONTROL AIR        | 43. LPA-4, ISLN-AIR RCVR NO. 2         |
| 21. CA-6, SEP/RGLTR                    | 44. LPA-35, RELIEF VLV-AIR RCVR NO. 2  |
| 22. CA-5, ISLN-SEP/RGTR                | 45. LPA-27, PRESS GAGE-AIR RCVR NO. 2  |
| 23. LPA-2, DISCH-AIR CPRSR NO. 2       |  |

Figure 1-15. Compressed Air Piping System (Sheet 5 of 5).

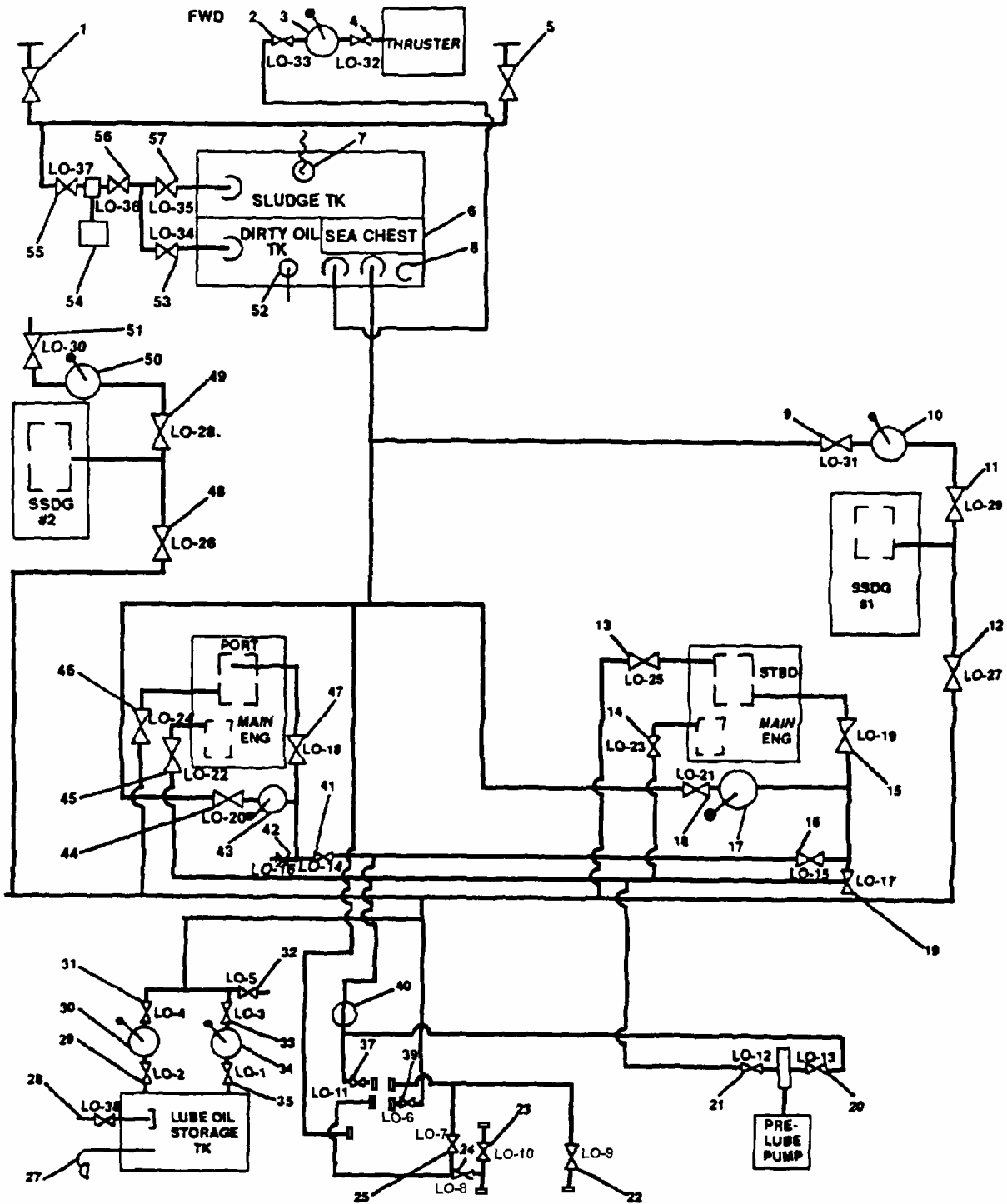


Figure 1-16. Lubricating Oil Transfer and Piping System (Sheet 1 of 2).

## LEGEND

- |                                     |                                     |
|-------------------------------------|-------------------------------------|
| 1. PORT DIRTY OIL DISCH             | 29. LO-2, STORAGE TK SUPPLY         |
| 2. LO-33, SUMP DISCH-BOW ENG        | 30. HAND PUMP NO. 2                 |
| 3. BOW ENG SUMP PUMP                | 31. LO-4, HAND PUMP NO. 2 DISCH     |
| 4. LO-32, SUMP SUCT-BOW ENG         | 32. LO-5, HAND SUPPLY               |
| 5. STBD DIRTY OIL DISCH             | 33. LO-3, HAND PUMP NO. 1 DISCH     |
| 6. SEA CHEST                        | 34. HAND PUMP NO. 1                 |
| 7. TANK LEVEL INDICATOR             | 35. LO-1, STORAGE TK SUPPLY         |
| 8. SOUNDING TUBE                    | 36. DELETED                         |
| 9. LO-31, SUMP DISCH-SSDG           | 37. LO-11, CAPPED                   |
| 10. STBD SSDG SUMP PUMP             | 38. DELETED                         |
| 11. LO-29, SUMP SUCT-SSDG           | 39. LO-6, CAPPED                    |
| 12. LO-27, SUMP SUPPLY              | 40. STRAINER                        |
| 13. LO-25, SUMP SUPPLY/RTN STBD ENG | 41. LO-14, PRE-LUBE SUCT            |
| 14. LO-23, PRE-LUBE RETURN-STBD ENG | 42. LO-16, RDCN GEAR SUCT-PORT      |
| 15. LO-19, SUMP SUCT-STBD ENG       | 43. MN ENG SUMP PUMP                |
| 16. LO-15, PRE-LUBE/SUCT            | 44. LO-20, MN ENG SUMP DISCH        |
| 17. STBD MN ENG SUMP PUMP           | 45. LO-22, PRE-LUBE RETURN-PORT ENG |
| 18. LO-21, MN ENG PUMP DISCH        | 46. LO-24, SUMP SUPPLY/RTN PORT ENG |
| 19. LO-17, RDCN GEAR SUCT-STBD      | 47. LO-18, SUMP SUCT-PORT ENG       |
| 20. LO-13, PRE-LUBE PUMP SUCT       | 48. LO-26, SUMP SUPPLY              |
| 21. LO-12, PRE-LUBE PUMP DISCH      | 49. LO-28, SUMP SUCT-SSDG           |
| 22. LO-9, CAPPED                    | 50. PORT SSDG SUMP PUMP             |
| 23. LO-10, CAPPED                   | 51. LO-30, SUMP DISCH-SSDG          |
| 24. LO-8, CAPPED                    | 52. TANK LEVEL INDICATOR            |
| 25. LO-7, CAPPED                    | 53. LO-34, DIRTY OIL TANK SUCT      |
| 26. DELETED                         | 54. DIRTY OIL PUMP                  |
| 27. VENT (LOCATED IN EMERG GEN RM)  | 55. LO-37, DIRTY OIL PUMP DISCH     |
| 28. LO-38, SSDG LUBE OIL TK         | 56. LO-36, DIRTY OIL PUMP SUCT      |

Figure 1-16. Lubricating Oil Transfer and Piping System (Sheet 2 of 2).

## NOTE

Paragraph 1-29 not applicable to vessels with OWS upgrade, MWO 55-1905-223-55-6. Reference TM 55-1905-223-24-19 for information for vessels that have the OWS upgrade MWO 55-1905-223-55-6 installed.

**1-29. Oily Water Separator Piping System.** The oily water separator piping system consists of a three-stage coalescer oil-water separator with pumps, motors and oil content alarm. The system separates and removes non-soluble oil, solids, and entrained air from the bilge water before it is discharged overboard. System control is maintained through a combination of valves as shown in FIGURE 1-17. Power for the oil-water separator is supplied by the MISC MCHRY POWER PANEL P204. A running indicator is provided on the engine room console panel.

**1-30. Sewage Piping System.** The sewage piping system collects and routes ship's sewage to the sewage treatment device and then to a through-hull overboard discharge. The sewage treatment device uses continual maceration and chlorination to decompose solids in the sewage. The decomposed chlorinated sewage is then discharged overboard. The sewage treatment device is supplied with power by the MISC MCHRY POWER PANEL P204, through a 240/120 Vac step-down transformer. Controls for the sewage treatment device are located on the unit.

**1-31. Propeller Shaft, Propeller, and Shaft Brake.** The propeller shaft transfers power provided by the main reduction gear and clutch to the propeller, which converts it to thrust required to move the vessel. The shaft brake stops and holds the propeller shaft when no torque is applied. The shaft is connected to the main reduction gear via the propeller shaft flange. The shaft is lubricated by water from the stern tube lubrication piping system. The air actuated shaft brake stops the propeller shaft rotation when torque is removed from the shaft. The brake is automatically actuated. Shaft locks allow manual locking of each shaft.

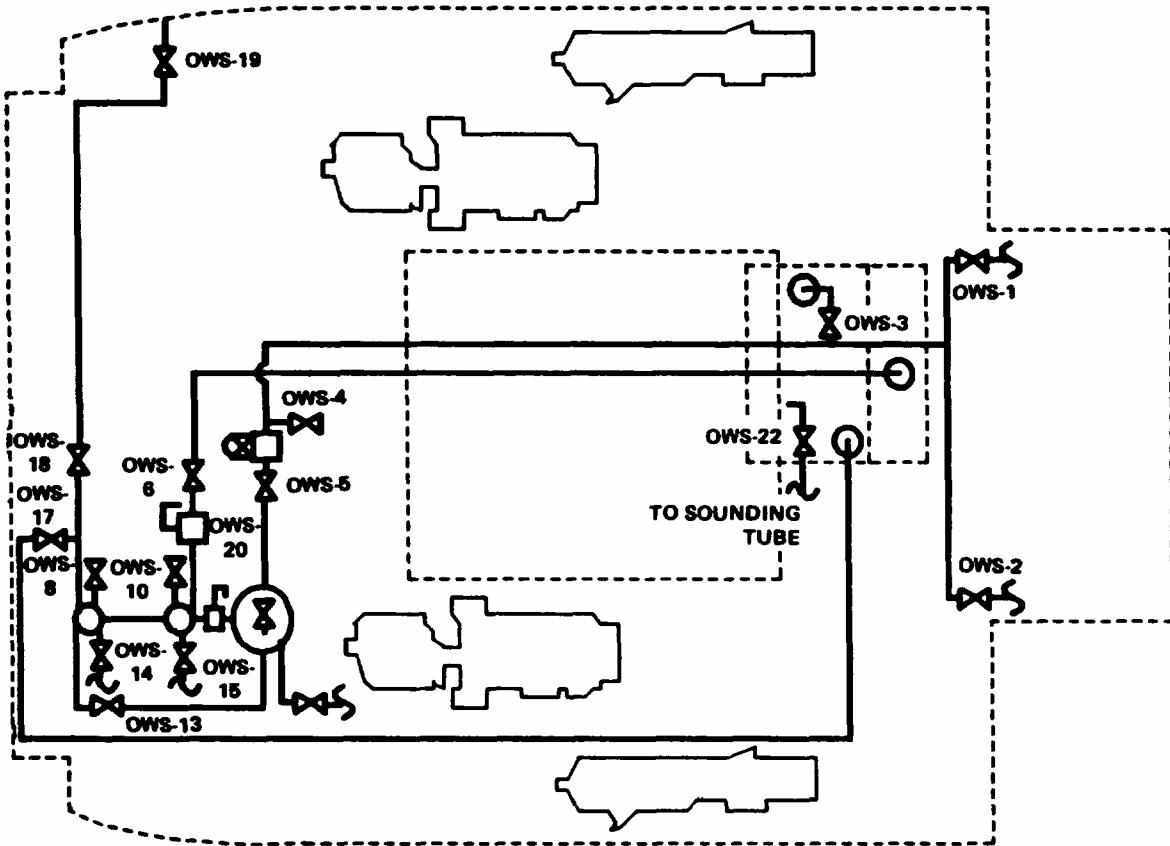
**1-32. Doors, Hatches, and Scuttles.** Doors, hatches, and scuttles provide access to spaces of either privacy, security, or watertight/fire tight integrity. Interior doors primarily provide access between above main deck interior spaces where security or watertight integrity is not a concern. Watertight doors provide access to interior spaces from weather spaces and to compartments where watertight integrity is a requirement. Hatches provide access to below main deck areas. Hatches offer watertight integrity when closed and dogged. When open, hatches allow transfer of equipment and personnel between decks. Scuttles provide emergency or restricted access to below deck engineering spaces. Dogged watertight doors are fitted to the bulkheads at each end of the tunnel. Flush access hatches are used on the cargo deck.

**1-33. Workboat/Liferafts.** The workboat functions as the utility small craft for operations such as sea rescue and personnel transport. The rigid, inflatable workboat has a 40-horsepower outboard motor. It is deployed and retrieved with an electrical winch crane. The electrical winch operates off ships power at 230 Vac, three-phase, 60 Hz. The unit is capable of 360-degree non continuous rotation. A hand crank is provided for manual slewing. The liferafts are designed for compact storage aboard ship and for quick inflation when necessary to abandon ship or for use in other emergencies. The liferaft is inflated by pulling on the "Automatic Painter." The liferaft release mechanism will automatically actuate if the ship sinks, due to pressure at 25 +/- 15 feet for the hydrostatic release and 5 to 15 feet for the release, lifesaving equipment. The container is inherently buoyant and floats to the surface.

**1-34. Airports, Fixed Lights, and Windows.** All glass onboard the LCU is heat treated and readily replaceable aboard ship. All windows, airports, fixed lights in exterior doors, glass doors, and panels (except pilothouse windows, which cause light to reflect on the structure) are provided with deadlight covers, light excluding shades, lined drapes, or other devices. Removable insert screens are provided for all air ports. Screens are designed to insert into the air ports from outside and fit air port dogs. The complete assembly is readily removable from the air port. Pilothouse front windows are slanted inward at the bottom for protection against glare.







LEGEND

- |                                    |  |
|------------------------------------|--|
| OWS-1, BILGE SUCTION               | OWS-8, 3RD STAGE EVENT                 |
| OWS-2, BILGE SUCTION               | OWS-7, 3RD STAGE PRESS GAGE            |
| OWS-12, 1ST STAGE EVENT            | OWS-17, RECIRC TO DIRTY OIL TANK       |
| OWS-16, 1ST STAGE DRAIN            | OWS-18, OVBD DISCH                     |
| OWS-11, 1ST STAGE PRESSURE GAGE    | OWS-19, OVBD DISCH                     |
| OWS-21, RELIEF VALVE SET AT 35 PSI | OWS-20, RELIEF VALVE SET AT 42 PSI     |
| OWS-15, 2ND STAGE DRAIN            | OWS-8, DISCH TO SLUGDE TK              |
| OWS-10, 2ND STAGE VENT             | OWS-5, 1ST STAGE SUCT                  |
| OWS-9, 2ND STAGE PESS GAGE         | OWS-4, FRESH WATER MKUP                |
| OWS-14, 3RD STAGE DRAIN            | OWS-3, DIRTY OIL TK SUCT               |
| OWS-13, OIL RETURN TO 1ST STAGE    | OWS-22, SNDG TUBE DIRTY OIL TK 331-O-F |

NOTE

Not applicable to vessels with OWS upgrade, MWO 55-1905-223-55-6.  
Reference TM 55-1905-223-24-19 for information for vessels that have the OWS upgrade MWO 55-1905-223-55-6 installed.

Figure 1-17. Oil-Water Separator Piping System.

CHAPTER 2

UNIT MAINTENANCE INSTRUCTIONS

	<u>Page</u>
Section I. Repair Parts, Special Tools; Test, Measurement, and Diagnostic Equipment (TMDE); and Support Equipment .....	2-1
Section II. Service Upon Receipt .....	2-1
Section III. Unit Preventive Maintenance Checks and Services (PMCS) .....	2-4
Section IV. Unit Troubleshooting .....	2-96
Section V. Unit Maintenance Procedures.....	2-183
Section VI. Preparation for Storage or Shipment .....	2-1074

**Section I. REPAIR PARTS, SPECIAL TOOLS; TEST, MEASUREMENT, AND DIAGNOSTIC EQUIPMENT (TMDE); AND SUPPORT EQUIPMENT**

**2-1. Common Tools and Equipment.** For authorized common tools and equipment, refer to the Modified Table of Organization and Equipment (MTOE), CTA 50-970, Expendable/Durable Items (Except: Medical Class V, Repair Parts, and Heraldic Items), CTA 50-909, Field and Garrison Furnishings and Equipment or CTA 8-100, Army Medical Department Expendable/Durable Items, as applicable to your unit.

**2-2. Special Tools, TMDE, and Support Equipment.** Special tools; test, measurement, and diagnostic equipment; and support equipment requirements are listed and illustrated in the Repair Parts and Special Tools List (RPSTL), TM 55-1905-223-24P. These items are also listed in the Maintenance Allocation Chart (MAC), Appendix B of this manual.

**2-3. Repair Parts.** Repair parts are listed and illustrated in the Repair Parts and Special Tools List (RPSTL), TM 55-1905-223-24P.

**Section II. SERVICE UPON RECEIPT**

**2-4. Checking Unpacked Equipment.**

- a. Inspect the equipment for damage incurred during shipment. If the equipment has been damaged, report the damage in accordance with the instructions of DA PAM 738-750.
- b. Check the equipment against the packing slip to see if the shipment is complete. Report all discrepancies in accordance with the instructions of DA PAM 738-750.
- c. Check to see whether the equipment has been modified.

**2-5. Deprocessing Equipment.**

- a. Remove protective caps, plugs, inserts, wrappings and tape when inspection/inventory is completed. Inspect piping openings for damage. Wipe off dirt, grease, or protective films at time of installation.
- b. Remove chocks from resilient mounted components.

**2-6. Preoperative Checks.** Before actual receipt of the LCU by the government, the vessel has undergone dockside trials as well as acceptance trials. All systems have been checked out during these trials. However, it is recommended that the following preoperative checks be made on the equipment before the vessel is put into normal operation.

**NOTE**

**Halon is not applicable to vessels with FM-200 Fire Suppressant System installed. Reference TM 55-1905-243-24&P, LCU-2000, FM-200 Fire Fighting System for maintenance and installation of FM-200 components.**

- a. Halon/Firefighting Equipment. Check all equipment for obvious damage. Visually inspect all halon systems and firefighting equipment for breakage, loose connections, proper stowage and ready availability for use.
- b. Furniture and Furnishings. Visually inspect all tables, chairs, beds, desks, wardrobes, safes, lockers and other furnishings for obvious breakage and proper operation.
- c. Entertainment System. Check television, video cassette recorder, video amplifier and omni-directional antenna for obvious breakage or damage. Operate equipment in accordance with TM 55-1905-223-10, Operator's Manual.
- d. Separators. Check diesel fuel oil filter/separator and oil-water separator for leaks, damage or missing components. Operate each system in accordance with TM 55-1905-223-10, Operator's Manual.
- e. Sound Powered Telephone System. Check all equipment for obvious damage, breakage and missing components. Operate all equipment in accordance with TM 55-1905-223-10, Operator's Manual.
- f. Tank Level Indicator System. As completely as practical, visually inspect all equipment and indicators for obvious damage and breakage. Operate system in accordance with TM 55-1905-223-10, Operator's Manual. Inspect all tanks for leaks, cracks or other obvious damage. Inspect voids for gear adrift and proper closures.
- g. Navigation System. Check that the searchlight, whistle, fog horn, bell and gong are in working order. Check navigation lights for breakage and obvious damage. Check all systems for proper operation in accordance with TM 55-1905-223-10, Operator's Manual.
- h. Machine Shop Equipment. Check all equipment in the Machine Shop for obvious damage or breakage. Operate all equipment in accordance with instructions in TM 55-1905-223-10, Operator's Manual.
- i. Commissary/Laundry Equipment. Check all equipment for obvious damage. Ensure all devices operate in accordance with TM 55-1905-223-10. Operator's Manual.

- j. Miscellaneous Pumps/Motors. Check the following pumps and their associated motors for obvious damage, leaks and loose connections:

Fresh water pump  
 Fresh water booster pump  
 Auxiliary seawater cooling pump  
 Fuel oil transfer pumps (2)  
 Lubricating oil standby pumps (2)  
 Lubricating oil transfer pumps (2)  
 Dirty oil pump  
 Reduction gear cooling water pumps (2)  
 Oil water separator pump  
 Distillate pumps (2)  
 Jacket water pumps (2)

Check operation in accordance with TM 55-1905-223-10, Operator's Manual.

- k. Controls Subsystems. Check for obvious damage. Ensure proper operation in accordance with TM 55-1905-223-10, Operator's Manual.
- l. Electrical Subsystems. Visually inspect all wiring runs and connection boxes for obvious damage, broken wires, stripped insulation or loose connections.
- m. Windows/Doors/Hatches. Check dogs, hinges, and locking devices for proper operation. Check gaskets for cracks, tears and missing material. Check condition of glass.
- n. Lashing Gear/Towing/Mooring Equipment. Visually check for obvious damage. Check all flush deck and raised bumper sockets for cracks or other damage.
- o. Workboat/Liferafts/Davit. Visually check for secure mounting and any obvious damage. Ensure davit and workboat operate in accordance with TM 55-1905-223-10, Operator's Manual.
- p. Control Centers/Switchboards. Visually inspect for obvious damage and loose connections.
- q. Propellers/Shafts. As far as practical, visually inspect for obvious damage or misalignment. During initial operation be alert for excessive vibration or leaks along the shaft and its connections.
- r. Valves/Strainers. Visually inspect all valves and strainers for secure connections and proper operation. Check for leaks under pressure. Ensure proper operation in accordance with TM 55-1905-223-10, Operator's Manual.
- s. Piping. Check all piping systems for leaks, damage or missing components. Operate each system in accordance with TM 55-1905-223-10, Operator's Manual.
- t. Hull/Ladders/Rails/Foundations. Visually check for obvious damage and missing components. Check security of life lines and rails. Check proper storage of portable ladders and gangways.
- 2-7. Initial Setup Procedure**. Includes operational checks and inspections that are not performed for a routine startup. Direct support maintenance personnel will perform initial setup in accordance with the TM 55-1905-223-10, Operator's Manual.

- 2-8. Normal Startup**. Refer to the TM 55-1905-223-10, Operator's Manual.

2-9. **Shutdown Procedure (Usual or Unusual).** Refer to the operator's manual, TM 55-1905-223-10.

### **Section III. UNIT PREVENTIVE MAINTENANCE CHECKS AND SERVICES (PMCS)**

2-10. **Explanation of PMCS Table.** PMCS is designed to keep the equipment in good working condition. This is accomplished by performing certain tests, inspections, and services. Table 2-1 lists items to be serviced and the procedures needed to accomplish the PMCS. The Interval listed at the top of the page tells you when to perform a check or service. If needed, PMCS may be performed more frequently than the indicated interval. The "Procedures" column tells you how to perform the required checks and services. If your equipment does not operate as required, see Table 2-2, Troubleshooting. Report any malfunctions or failures on DA Form 2404. In the Item Number column on DA Form 2404, record the appropriate Item Number from the PMCS Table.

Table 2-1. Preventive Maintenance Checks and Services

D - Daily    W - Weekly    M - Monthly    Q - Quarterly    S - Semiannually    A - Annually

Item No.	Interval						Items To Be Inspected/Service	Procedures																																																																
	D	W	M	Q	S	A																																																																		
1			•				Halon System	<p><b>NOTE</b>                      Halon Firefighting system is not applicable to vessels with FM-200 Fire Suppressant System installed. Reference TM 55-1905-243-24&amp;P, LCU-2000, FM-200 Fire Fighting System for maintenance and installation of FM-200 components.</p> <p><u>HALON FIREFIGHTING SYSTEM</u>                      Inspect system for loose components, loose connections, corrosion, breaks, and bent tubing. Tighten loose connections hand tight plus 1/4 turn.</p> <p>Use the temperature correction table listed below to determine what the correct pressure reading should be, then check readings on gauges located on halon tank valves. If pressure is below tolerance specified on name plate, notify Intermediate General Support Maintenance.</p> <p><u>Temperature Corrections</u>  <u>360 psi Nominal System</u></p> <table border="1"> <thead> <tr> <th colspan="2">Temperature</th> <th>Nominal Pressure</th> <th>Minimum Allowable Pressure</th> </tr> <tr> <th>°F</th> <th>(°c)</th> <th>psi</th> <th>psi</th> </tr> </thead> <tbody> <tr><td>0</td><td>(-18)</td><td>195</td><td>175</td></tr> <tr><td>+ 10</td><td>(-12)</td><td>212</td><td>191</td></tr> <tr><td>+ 20</td><td>(- 7)</td><td>231</td><td>208</td></tr> <tr><td>+ 30</td><td>(- 1)</td><td>253</td><td>228</td></tr> <tr><td>+ 40</td><td>(+ 4)</td><td>276</td><td>248</td></tr> <tr><td>+ 50</td><td>(+10)</td><td>301</td><td>271</td></tr> <tr><td>+ 60</td><td>(+16)</td><td>330</td><td>297</td></tr> <tr><td>+ 70</td><td>(+21)</td><td>360</td><td>324</td></tr> <tr><td>+ 80</td><td>(+27)</td><td>393</td><td>354</td></tr> <tr><td>+ 90</td><td>(+32)</td><td>429</td><td>386</td></tr> <tr><td>+100</td><td>(+38)</td><td>468</td><td>421</td></tr> <tr><td>+110</td><td>(+43)</td><td>511</td><td>460</td></tr> <tr><td>+120</td><td>(+49)</td><td>557</td><td>501</td></tr> <tr><td>+130</td><td>(+54)</td><td>607</td><td>546</td></tr> </tbody> </table>	Temperature		Nominal Pressure	Minimum Allowable Pressure	°F	(°c)	psi	psi	0	(-18)	195	175	+ 10	(-12)	212	191	+ 20	(- 7)	231	208	+ 30	(- 1)	253	228	+ 40	(+ 4)	276	248	+ 50	(+10)	301	271	+ 60	(+16)	330	297	+ 70	(+21)	360	324	+ 80	(+27)	393	354	+ 90	(+32)	429	386	+100	(+38)	468	421	+110	(+43)	511	460	+120	(+49)	557	501	+130	(+54)	607	546
Temperature		Nominal Pressure	Minimum Allowable Pressure																																																																					
°F	(°c)	psi	psi																																																																					
0	(-18)	195	175																																																																					
+ 10	(-12)	212	191																																																																					
+ 20	(- 7)	231	208																																																																					
+ 30	(- 1)	253	228																																																																					
+ 40	(+ 4)	276	248																																																																					
+ 50	(+10)	301	271																																																																					
+ 60	(+16)	330	297																																																																					
+ 70	(+21)	360	324																																																																					
+ 80	(+27)	393	354																																																																					
+ 90	(+32)	429	386																																																																					
+100	(+38)	468	421																																																																					
+110	(+43)	511	460																																																																					
+120	(+49)	557	501																																																																					
+130	(+54)	607	546																																																																					
2			•				Halon Tanks																																																																	

Change 5

2-5

TM 55-1905-223-24-18-1

Table 2-1. Preventive Maintenance Checks and Services - Cont.

D - Daily    W - Weekly    M - Monthly    Q - Quarterly    S - Semiannually    A - Annually

Item No.	Interval						Items To Be Inspected/Service	Procedures
	D	W	M	Q	S	A		
3			•				Omni Directional Antenna	<p><u>ENTERTAINMENT SYSTEM</u></p> <p>Inspect antenna elements and wiring connections for corrosion and breaks.</p> <p><u>SEPARATORS</u></p> <p><b>NOTE</b></p> <p>Item numbers 4 through 12 deleted due to Lube Oil Purifier removal from all vessels during Waste Heat Evaporator upgrade MWO 55-1905-223-55-3.</p>



Table 2-1. Preventive Maintenance Checks and Services - Cont.

D - Daily    W - Weekly    M - Monthly    Q - Quarterly    S - Semiannually    A - Annually

Item No.	Interval						Items To Be Inspected/Service	Procedures
	D	W	M	Q	S	A		
<b><u>SEPERATORS - CONT</u></b>								
13	•						Circulation Heater	Inspect circulation heater for secure mounting and for leaks.
14	•						Fuel Oil Filter Separator	Inspect exterior for obvious damage or leaks.  Replace filter once per year or when differential pressure gauge exceeds 20 psi.
15	•						Oil-Water Separator Exterior	<p style="text-align: center;"><b>NOTE</b></p> <p style="text-align: center;"><b>Item 15 not applicable to vessels with OWS upgrade, MWO 55-1905-223-55-6. Reference TM 55-1905-223-24-19 for information for vessels that have the OWS upgrade MWO 55-1905-223-55-6 installed.</b></p> Visually inspect unit for leaks, loose connections, and damage.  1 <sup>st</sup> Stage Gauge should read less than 20 psi.  2 <sup>nd</sup> Stage Gauge should read less than 10 psi.

Table 2-1. Preventive Maintenance Checks and Services - Cont.

D - Daily    W - Weekly    M - Monthly    Q - Quarterly    S - Semiannually    A - Annually

Item No.	Interval						Items To Be Inspected/Service	Procedures
	D	W	M	Q	S	A		
15	•						Oil-Water Separator Exterior - CONT	<p><u>SEPARATORS - CONT</u></p> <p>3rd Stage Gauge should read less than 10 psi.</p> <p>Outlet Gauge should read less than 40 psi.</p> <p>Differential Pressure Gauge should read less than 5 psi.</p>
16		•					Head Set - Chest Set	<p><u>SOUND POWERED TELEPHONES</u></p> <p>Visually inspect head set connections to the chest set for frayed wiring or loose connections. Inspect ear cups for tears and cleanliness. Inspect neck straps for fraying or missing fasteners. Press pushbutton on mouthpiece and release. Observe push button goes in and out. Visually inspect wire from chest set to jack plug for loose connections, cracks on damaged insulation.</p> <p>Check the two-way voice capability of the head set. Select another station on the system and conduct a two-way conversation. Transmission and receptions should be clear, undistorted and easily understood.</p>
		•					Handset Exterior	<p>Visually inspect the handset and wiring for loose connections. Tighten as necessary. Visually inspect exterior for damage or dirt buildup. Clean using a soft, clean cloth.</p>
		•					Hardware	<p>Inspect mounting hardware for tightness. Tighten as necessary.</p>

Table 2-1. Preventive Maintenance Checks and Servicer - Cont.

D - Daily W - Weekly M - Monthly Q - Quarterly S - Semiannually A - Annually

Item No.	Interval						Item To Be Inspected/ Serviced	Procedures
	D	W	N	Q	S	A		
<u>SOUND POWERED TELEPHONES - CONT</u>								
16		●					Rotary Switches  Operation	Check mechanical operation of each rotary switch. Document any worn part or incorrectly operating parts and refer to unit maintenance.  Check the two-way voice capability of the unit. Select other stations and conduct a two-way conversation.  a. Transmissions and receptions should be clear, undistorted and easily understood.  b. Check the audible and light indicators. On models SELR and SFLR the indicator lights should light along with the calling signal.
17			●				Tank Level Indicator System Lights and Lamps (5)	Inspect for security, breakage, and proper operation. Replace defective lights or lamps as specified in paragraphs 2-32 or 2-33.
18			●				Tank Level Indicator System Fuses (6)	Inspect for defective fuses. Replace defective fuses as specified in paragraphs 2-32 or 2-33.

Table 2-1. Preventive Maintenance Checks and Services - Cont.

D - Daily W - Weekly M - Monthly Q - Quarterly S - Semiannually A - Annually

Item No.	Interval						Items To Be Inspected/ Serviced	Procedures
	D	W	M	Q	S	A		
19		●					<p>Port Running Light, Star-board Running Light, Mast Head Lights, Stern Lights, Anchor Lights, Not-Under-Command Lights, Yardarm Blinker Lights</p>	<p><b><u>NAVIGATION SIGNAL AND SEARCHLIGHTS</u></b></p> <p>Inspect for broken and/or missing lens, bulbs and gaskets on light fixtures. Turn lights on and off to test lights for proper operation.</p>
20		●					XENON Searchlight	<p>Check for dents and corrosion on housing, cracked cover glass, burned out filament and damaged gaskets.</p>
21		●					XENON Searchlight, Reflector	<p><b><u>WARNING</u></b></p> <p>Lock power supply in OFF position. Eye protection must be worn.</p> <p>Clean with a soft cloth (Item 4, Appendix C). Do not use coarse scratchy material. Clean with silver polish (Item 17, Appendix C).</p>

Table 2-1. Preventive Maintenance Checks and Services - Cont.

D - Daily W - Weekly M - Monthly Q - Quarterly S - Semiannually A - Annually

Item No.	Interval						Items To Be Inspected/ Serviced	Procedures
	D	W	M	Q	S	A		
22		●					XENON Searchlight, Power Supply	<p align="center"><b><u>NAVIGATION SIGNAL AND SEARCHLIGHTS - CONT</u></b></p> <p>Turn the searchlight on and feel for air flow at exhaust opening to ensure the fan in the power supply is operating properly.</p> <p>Clean with damp, soft cloth (Item 4, Appendix C).</p> <p>Read ammeter on power supply. If necessary, adjust set screw until reading is between 24 to 26 amperes.</p> <p>Remove dust accumulation with a long fine brush (Item 18, Appendix C) or air blast.</p> <p>Inspect for cleanliness, breakage and toggle switch movement.</p> <p>Inspect electric horn, power supply, timer, panel assembly and rotary switch for cleanliness and obvious damage. Sound horn to test operation of circuits.</p>
23		●					XENON Searchlight, Power Supply Glass	
24		●					XENON Searchlight, Lamp	
25		●					XENON Searchlight, Rectifier	
26		●					Navigation Panel Lights and Switches	
27		●					Electric Horn	

Table 2-1. Preventive Maintenance Checks and Services - Cont.

D - Daily W - Weekly M - Monthly Q - Quarterly S - Semiannually A - Annually

Item No.	Interval						Items To Be Inspected/ Serviced	Procedures
	D	W	M	Q	S	A		
28	•						<p style="text-align: center;"><b><u>MACHINE SHOP EQUIPMENT</u></b></p> <p>a. Visually inspect the machinery shop for loose parts, tools or heavy objects that may fall or slide in heavy seas. Secure loose objects.</p> <p>b. Ensure decking is secure, lights are operational, shop is clean and free of salt deposits, no flammable liquids stowed in shop, shop is free of trash, and other solid flammables.</p> <p>Visually Inspect the Vise and Bench Grinder.</p> <p>(1) Look for loose connections on the grinder, excess buildup of metal residue and chips on the grinding wheels .</p> <p>(2) Rotate the vise clamp wheels and check for ease of motion.</p> <p>a, Using clean, dry, air, blow out dust and dirt.</p> <p>b. Visually inspect for fraying, broken wires, cuts and damaged insulation.</p> <p style="text-align: center;"><b><u>WARNING</u></b></p> <p>Be sure power is OFF at switchboard or serious injury could result. Power switch on welding machine does not remove all power from inside of machine.</p>	
29			•			Vise and Bench Grinder		
30			•			Arc Welding Machinery		

Table 2-1. Preventive Maintenance Checks and Services - Cont.

D - Daily W - Weekly M - Monthly Q - Quarterly S - Semiannually A - Annually

Item No.	Interval						Items To Be Inspected/ Serviced	Procedures
	D	W	M	Q	S	A		
30			●				Arc Welding Machine - CONT	<p style="text-align: center;"><b><u>MACHINERY SHOP EQUIPMENT - CONT</u></b></p> <p>c. Turn electrical power unit to OFF at the ship service switchboard. Tag switch "Out of Service - Do Not Operate." Refer to TM 55-1905-223-10.</p> <p>d. Use filler gauge to check spark gap of 0.008 inch (0.020 cm). Adjust as necessary.</p> <p>e. Remove high frequency spark gap access panel from right side panel of arc welder unit.</p> <p>f. Loosen pan head screw that secures each single spark gap assembly.</p> <p>g. Insert 0.008-inch (0.020 cm) feeler gauge between spark gap contact points.</p> <p>h. Move loosened contact point until slight drag is felt as gauge is moved between the points.</p> <p>i. Tighten the loosened pan screw to secure contact point assembly.</p> <p>j. Repeat steps b. through e. for other spark gap contact points.</p> <p>k. Install access panel.</p> <p>l. Remove tag and turn ON electrical power at the ship service switchboard.</p>

Table 2-1. Preventive Maintenance Checks and Services - Cont.

D - Daily W - Weekly M - Monthly Q - Quarterly S - Semiannually A - Annually

Item No.	Interval						Items To Be Inspected/ Serviced	Procedures
	D	W	M	Q	S	A		
31			●				<p style="text-align: center;"><b><u>MACHINERY SHOP EQUIPMENT- CONT</u></b></p> <p>Visually inspect all cables and connections for damaged insulation, cuts, broken wires, and fraying.</p>	
32	●						<p style="text-align: center;"><b><u>COMMISSARY AND LAUNDRY</u></b></p> <p>*NOTE: Performed After Every Use</p> <p>a. Clean and season griddle.</p> <p>b. Clean range top with warm soapy water.</p> <p>c. Empty grease drawer.</p>	
33	●						<p>a. Clean range cabinet and oven with warm soapy water.</p> <p>b. Clean outside cabinet with warm soapy water. Dry thoroughly.</p>	
34	●						<p>Clean mixing bowl and attachments.</p> <p>Inspect electrical connections to ensure there is good contact and wires are not frayed.</p> <p>Clean mixer with warm soap water. Dry thoroughly.</p> <p>Change transmission oil every six months or 1000 hours of operation. Use #50 heavy duty oil (Hydrol Master 500 or equivalent).</p>	



Table 2-1. Preventive Maintenance Checks and Services - Cont.

D - Daily W - Weekly M - Monthly Q - Quarterly S - Semiannually A - Annually

Item No.	Interval						Items To Be Inspected/ Serviced	Procedures
	D	W	M	Q	S	A		
35		•					Meat Slicer	<p align="center"><b><u>COMMISSARY AND LAUNDRY - CONT</u></b></p> <p>Add 2 ounces of Soilax to 1 gallon of water and thoroughly wash the entire outside of slicer. Raise. Add 2 teaspoons of Mikro-Kleen to 1 gallon of water and sanitize slicer. Allow to dry, then cover.</p>
36	•						Compactor	<p>Wipe exterior with warm soapy water.</p> <p>a. Clean inside of drawer with warm soapy water. Dry with a soft cloth.</p> <p>b. Replace air freshener.</p> <p>c. Clean ram cover with warm soapy water. Dry with a soft cloth.</p> <p>d. Vacuum inside of cabinet.</p>
37		•		•			Electric Dryer	<p>Clean lint filter.</p> <p>Clean exterior of cabinet with warm soapy water. Dry thoroughly.</p> <p>Inspect electrical connections to ensure there is good contact and wires are not frayed.</p>

Table 2-1. Preventive Maintenance Checks and Services - Cont.

D - Daily W - Weekly M - Monthly Q - Quarterly S - Semiannually A - Annually

Item No.	Interval						Items To Be Inspected/ Serviced	Procedures
	D	W	M	Q	S	A		
38		•					Refrigerators /Freezers	<p style="text-align: center;"><u>COMMISSARY AND LAUNDRY - CONT</u></p> <p>Inspect condenser coil to make sure that air flow is not hampered and that it is clear of dust and debris.</p> <ol style="list-style-type: none"> <li>a. Inspect and clean drain line.</li> <li>b. Check the liquid refrigerant sight glass to ensure system is fully charged.</li> <li>c. Wipe down the interior liner with a mild soap and warm water solution.</li> <li>d. Check condenser fan motor and evaporator fan motor to ensure that they are operational and fans are tight and secure.</li> <li>e. Wipe door gaskets and breaker strips with a damp cloth.</li> <li>f. Clean exterior with mild soap and warm water. Dry thoroughly.</li> </ol> <ol style="list-style-type: none"> <li>a. Slide condensing unit from compartment and check all fittings for signs of leaks or fatigue.</li> <li>b. Inspect electrical connectins to ensure there is good contact and wires are not frayed.</li> </ol>

Table 2-1. Preventive Maintenance Checks and Services - Cont.

D - Daily    W - Weekly    M - Monthly    Q - Quarterly    S - Semiannually    A - Annually

Item No.	Interval						Items To Be Inspected/ Serviced	Procedures
	D	W	M	Q	S	A		
39		●					Dishwasher	<p align="center"><u>COMMISSARY AND LAUNDRY - CONT</u></p> <p>Clean inside of dishwasher with warm soapy water. Clean and Inspect Lighting and Power Distribution Panels.</p> <p>(1) Deenergize power supplies to distribution panel and tag "Out of Service - Do Not Operate.</p> <p>(2) Open or remove access covers.</p> <p>(3) Test with voltage tester to ensure electrical circuits are deenergized.</p> <p>(4) Vacuum panel; use dusting brush to loosen dirt</p>
40			●				Washer Machine	<p>a. Inspect hoses for splits or cracks.</p> <p>b. Inspect drive belt for excessive wear. Clean outside cabinet with warm soapy water.</p> <p>Inspect electrical connections to ensure there is good contact and wires are not frayed.</p>

Table 2-1. Preventive Maintenance Checks and Services - Cont.

D - Daily W - Weekly M - Monthly Q - Quarterly S - Semiannually A - Annually

Item No.	Interval						Items To Be Inspected/ Serviced	Procedures
	D	W	H	Q	S	A		
41	●						<p align="center"><b><u>MISCELLANEOUS PUMPS/MOTORS</u></b></p> <p>a. Visually inspect for leaks, proper operation, and cleanliness of pump unit. When shutdown authorized, wipe pump unit with clean, dry cloth.</p> <p>b. Thoroughly inspect and clean piping system, electrical circuit breakers, distribution panel, motor controllers, and switches at end of daily operation.</p> <p>a. Check for loose connections fittings and missing hardware.</p> <p>b. Investigate unusual noises or vibrations.</p> <p>c. Check all support mounts/brackets/bolts for tightness. Tighten as needed.</p> <p>Visually inspect the panels for security, broken lens, missing parts, etc. Inspect electrical wiring for breaks, loose ends, frayed wiring and security in the wiring runs and bundles. Turn power ON and check for defective gauges, bulbs, etc.</p> <p>a. Check suction/discharge gauges for unusual indications or fluctuations. Clean, repair, replace pressure lines/gauges.</p> <p>b. Check and clean filter/traps and piping system/</p> <p>c. When shutdown authorized, repair/replace pump/motor if required.</p>	
42		●						
43		●						
44			●					

Table 2-1. Preventive Maintenance Checks and Services - Cont.

D - Daily W - Weekly M - Monthly Q - Quarterly S - Semiannually A - Annually

Item No.	Interval						Items To Be Inspected/ Serviced	Procedures
	D	W	M	Q	S	A		
45				●			<p style="text-align: center;"><u>MISCELLANEOUS PUMPS/MOTORS - CONT</u></p> <p>a. Inspect/clean pump impeller, pump casing.</p> <p>b. Check for damage and corrosion.</p> <p>c. Inspect pump/motor electrical wiring and connections.</p> <p>d. Check serviceability of START and STOP pushbuttons on engine room console panel.</p> <p>e. Check for loose connections on main switchboard 240 V distribution.</p> <p>f. Check for loose connections on engine room console panel.</p> <p>g. Check for loose connections on hydropneumatic pressure tank pressure switches.</p> <p>h. Tighten/replace connections as needed.</p>	

Table 2-1. Preventive Maintenance Checks and Services - Cont.

D - Daily W - Weekly M - Monthly Q - Quarterly S - Semiannually A - Annually

Item No.	Interval						Items To Be Inspected/ Serviced	Procedures
	D	W	M	Q	S	A		
46					●		<p style="text-align: center;"><b><u>MISCELLANEOUS PUMPS/MOTORS - CONT</u></b></p> <p>Miscellaneous Pumps and Motors</p> <ol style="list-style-type: none"> <li>a. Inspect for security, cracks, and deterioration of electrical wiring.</li> <li>b. Check for evidence of burning or overheating of wire insulation.</li> <li>c. Inspect for corrosion, chipped paint, excessive wear of electrical wiring to pump motor.</li> <li>d. Check security of cable harnesses between 240 V distribution on main switchboard, engine room console panel and pump motor.</li> <li>e. Inspect piping system for corrosion.</li> <li>f. Inspect hydropneumatic pressure tank for corrosion.</li> <li>g. Check tank for leaks, security, hatch and gasket condition, missing or broken fittings/parts.</li> <li>h. Corrective measure taken for corrosion control. Touch up painting as needed.</li> </ol>	

Table 2-1. Preventive Maintenance Checks and Services - Cont.

D - Daily W - Weekly M - Monthly Q - Quarterly S - Semiannually A - Annually

Item No.	Interval						Items To Be Inspected/ Serviced	Procedures
	D	W	M	Q	S	A		
47				●			<p style="text-align: center;"><b><u>CONTROLS SYSTEMS</u></b></p> <p>a. Inspection.</p> <p>(1) Operate the systems, observe the function for normal operational, Ahead and Astern. Recommend system supply pressure, 120 psi.</p> <p>(2) During operation, check for air leaks at tubing fittings, valves, and actuator seals by using liquid leak detector. Assure all tubing is secured and insulated from excessive vibration, check all flexible hoses for cracking, aging, or chafing.</p> <p>(3) With the system actuated Ahead, inspect for the following, then check again while actuated Astern.</p> <p>(a) The 3-position gear actuator cylinder should move freely without binding or twisting. The same is true for the governor actuator. Check all linkages and adjustments for correct alignment.</p> <p>(b) Check all pivot points for freedom of movement, excessive wear and corrosion.</p> <p>(c) Check valve indicator pins or stem positions and ensure all are in proper sequence. (Refer to trouble locator guide.)</p>	

Table 2-1. Preventive Maintenance Checks and Services - Cont.

D - Daily    W - Weekly    M - Monthly    Q - Quarterly    S - Semiannually    A - Annually

Item No.	Interval						Items To Be Inspected/ Serviced	Procedures
	D	W	M	Q	S	A		
47				●			Control Sub-systems - Cont	<p style="text-align: center;"><u><b>CONTROLS SYSTEMS - CONT</b></u></p> <p>(d) Check all operating pressures for normal settings.</p> <p>(e) Check all system components for cleanliness. Exercise care to ensure that excessive dust, dirt, and foreign objects are not allowed to build up around and/or on any system components.</p> <p>(f) Turn the system air off at the air prep unit shut-off valve. After all system air has bled out, remove the filter unit bowl, drain it, wipe it clean, inspect the filter element, and install the bowl. Be sure the auto drain float (if used) is positioned properly and lock ring is in locked position. Slowly turn on air to prevent system shock.</p> <p>b. Cleaning/Lubrication.</p> <p>(1) Turn control system air off at the air prep unit and wait for pressure to bleed off completely before proceeding.</p> <p>(2) Disconnect the component to be served and remove it from its installation. Plug or cap the air line connection removed from the component to prevent foreign objects from entering air lines.</p>



Table 2-1. Preventive Maintenance Checks and Services - Cont.

D - Daily W - Weekly M - Monthly Q - Quarterly S - Semiannually A - Annually

Item No.	Interval						Items To Be Inspected/ Serviced	Procedures
	D	W	M	Q	S	A		
47				●			Control Sub-systems - Cont	<p style="text-align: center;"><b><u>CONTROLS SYSTEMS - CONT</u></b></p> <p>(3) Disassemble the component to expose all serviceable parts. Refer to individual component assembly during disassembly and reassembly. Use a clean, well-lighted work area.</p> <p style="text-align: center;"><b>NOTE</b></p> <p>The lever assembly of the B202-1009 governor actuator does not have to be removed as bearings are prepacked. DO NOT submerge lever assembly in solvent.</p> <p>(4) Clean all parts (except rubber parts) with petroleum base solvent, mineral spirits (Stoddard solvent) or kerosene, and air dry. Clean rubber parts with soap and water, then air dry.</p> <p>(5) Ensure all parts are clean and free of residue. Check all parts for wear, corrosion or damage. Check diaphragms, "O" rings, and seals. Replace if cracked, hardened, or worn.</p> <p>(6) Replace all suspect parts. During assembly, lubricate each part using Lubriplate No. 107 (Item 6, Appendix C) on metal to metal moving surfaces and Pneumatic Grease No. 55 (Item 7, Appendix C) on all rubber parts.</p>

Table 2-1. Preventive Maintenance Checks and Services - Cont.

D - Daily    W - Weekly    M - Monthly    Q - Quarterly    S - Semiannually    A - Annually

Item No.	Interval						Items To Be Inspected/ Serviced	Procedures
	D	W	M	Q	S	A		
48	●						Bow Ramp Controls Exterior	Visually inspect exterior for obvious damage or missing parts.
49		●					Operation	Ensure bow ramp responds properly to control box.
50	●						Bowthruster Control Panel	Press LAMP CHECK pushbutton. Ensure all lamps operate.
51		●					Flood Lights	<p style="text-align: center;"><b><u>ELECTRICAL SYSTEM</u></b></p> Check for proper operation of switches and bulbs. Check for loose connections, cracked or missing lenses and secure mounting.
52		●					Fluorescent and Incandescent Lights	Check for proper operation of switches and bulbs. Check for loose connections, cracked or missing lenses and secure mounting.
53			●				Power Distribution Panels	<p style="text-align: center;"><b>NOTE</b></p> Perform this requirement monthly or when ground indicators indicate low resistance.
								a. Preliminary.
								(1) Ensure switchboard and associated system are not in operation.

Table 2-1. Preventive Maintenance Checks and Services - Cont.

D - Daily W - Weekly M - Monthly Q - Quarterly S - Semiannually A - Annually

Item No.	Interval						Items To Be Inspected/ Serviced	Procedures
	D	W	M	Q	S	A		
53			●				<p>Power Distribution Panels - CONT</p> <p>(2) Deenergize power sources to panel and tag, "Out of Service - Do Not Operate.</p> <p>(3) Position all circuit breakers on panel to OFF.</p> <p>(4) Open and/or remove access covers, as required. Lock doors in full open position.</p> <p style="text-align: center;"><u><b>WARNING</b></u></p> <p style="text-align: center;"><b>Voltage dangerous to life exists when equipment is open and energized. Do not work alone.</b></p> <p>b. Clean and inspect power panels and associated equipment.</p> <p style="text-align: center;"><b>NOTE</b></p> <p style="text-align: center;">Perform the following for each power panel.</p> <p>(1) Clean accessible areas, utilizing dusting brush (Item 18, Appendix C), and vacuum cleaner; use 1-inch paintbrush (Item 26, Appendix C) to clean hard-to-reach areas.</p>	

Table 2-1. Preventive Maintenance Checks and Services - Cont.

D - Daily W - Weekly M - Monthly Q - Quarterly S - Semiannually A - Annually

Item No.	Interval						Items To Be Inspected/ Serviced	Procedures
	D	W	M	Q	S	A		
53			●				<p style="text-align: center;"><u><b>ELECTRICAL SYSTEM - CONT</b></u></p> <p>Power Distribution Panels - CONT</p> <p>(2) Wipe accessible painted areas with a cloth; remove oil/grease stains with solvent.</p> <p>(3) Inspect interior and exterior, as appropriate, for the following:</p> <p>(a) Loose mechanical and electrical connections.</p> <p>(b) Missing hardware.</p> <p>(c) Kinks, sharp bends, or stresses in wiring.</p> <p>(d) Broken or wrinkled cable sheath.</p> <p>(e) Cracked or frayed insulation.</p> <p>(f) Foreign matter.</p> <p>(g) Damaged or missing circuit breakers, lamp assemblies, globes, and fuse carriers.</p> <p>(h) Hissing, damaged, or loose switch label plates and switch handles.</p> <p>(4) Remove, repair, or replace as necessary.</p> <p>(5) Where applicable, apply a light coat of grease to door hinges.</p>	

Table 2-1. Preventive Maintenance Checks and Services - Cont.

D - Daily W - Weekly M - Monthly Q - Quarterly S - Semiannually A - Annually

Item No.	Interval						Items To Be Inspected/ Serviced	Procedures
	D	W	M	Q	S	A		
53			●				Power Distribution Panels - CONT	<p style="text-align: center;"><b><u>ELECTRICAL SYSTEM - CONT</u></b></p> <p>(6) Close or reinstall access covers.</p> <p>(7) Remove safety tags.</p> <p>(8) Return equipment to readiness condition.</p>
54			●				Battery Storage Group	<p>a. Deenergize/disconnect battery chargers, where applicable, and tag "Out of Service - Do Not Operate."</p> <p style="text-align: center;"><b><u>WARNING</u></b></p> <p style="text-align: center;">Observe NO SMOKING regulations.</p> <p>b. Clean and Inspect Battery.</p> <p>(1) Clean battery with a lint-free towel dampened in baking soda and distilled water solution.</p> <p>(2) Rinse battery with distilled water.</p> <p>(3) Dry battery with a lint-free towel.</p> <p>(4) Inspect case for cracks and evidence of leakage.</p> <p>(5) Inspect terminal posts, cable connectors, and cell connectors for loose and broken connections.</p> <p>(6) Apply thin film of grease to terminal posts, cable connectors, and cell connectors.</p>

Table 2-1. Preventive Maintenance Checks and Services - Cont.

D - Daily W - Weekly M - Monthly Q - Quarterly S - Semiannually A - Annually

Item No.	Interval						Items To Be Inspected/ Serviced	Procedures
	D	W	M	Q	S	A		
54			●				<p>Battery Storage Group - CONT</p> <p>(7) Repeat steps a. through f. for remaining batteries.</p> <p>(8) Installations having ventilation ducting; ensure air passages are free of obstruction.</p> <p>a. Measure Portable Storage Battery Electrolyte Specific Gravity.</p> <p style="text-align: center;"><b><u>WARNING</u></b></p> <p style="text-align: center;">Observe NO SMOKING regulations.</p> <p style="text-align: center;"><b>NOTE</b></p> <p>Batteries having float indicators do not require steps a. through i.; however state of charge must be noted.</p> <p>(1) Remove battery vent and fill plugs.</p> <p>(2) Insert thermometer into one cell, ensure the thermostat bulb is completely immerse in electrolyte.</p> <p>(3) Draw electrolyte into hydrometer until float is floating freely and electrolyte in barrel is free of air bubbles.</p>	
55		●						

Table 2-1. Preventive Maintenance Checks and Services - Cont.

D - Daily W - Weekly M - Monthly Q - Quarterly S - Semiannually A - Annually

Item No.	Interval						Items to be Inspected/ Serviced	Procedures
	D	W	M	Q	S	A		
55		●					<p>Battery Storage Group - CONT</p> <p style="text-align: center;"><b><u>ELECTRICAL SYSTEM - CONT</u></b></p> <p>(4) Raise hydrometer to eye level and observe scale reading at bottom of curved surface of liquid.</p> <p>(5) Void hydrometer into cell from which electrolyte was drawn.</p> <p>(6) Observe temperature indicated on cell thermometer; correct specific gravity to 80°F. Specific gravity should not be less than 1.180.</p> <p>(7) Remove thermometer from cell.</p> <p style="text-align: center;"><b>NOTE</b></p> <p style="text-align: center;">This cell should not be selected for next temperature and specific gravity reading.</p> <p>(8) Inspect electrolyte level in each cell; fluid should be just below bottom of filling tube or approximately 3/8-inch above top of separators.</p> <p>(9) Reinstall vent and fill plugs.</p> <p>(10) Repeat steps a. through i. for remaining batteries.</p> <p>(11) Return equipment to readiness condition.</p>	

Table 2-1. Preventive Maintenance Checks and Services - Cont.

D - Daily W - Weekly M - Monthly Q - Quarterly S - Semiannually A - Annually

Item No.	Interval						Items To Be Inspected/ Serviced	Procedures
	D	W	M	Q	S	A		
55		●					Battery Storage Group - CONT	<p align="center"><b><u>ELECTRICAL SYSTEM - CONT</u></b></p> <p>b. Perform Functional Test of Engine Starting Batteries.</p> <p>(1) Verify that engine can be started in accordance with posted operating instructions.</p> <p>(2) Start engine.</p> <p>(3) Ensure batteries are capable of cranking and starting engine.</p> <p>(4) Stop engine.</p> <p>(5) If batteries are not functional:</p> <p>(a) Apply normal charge.</p> <p>(b) Repeat steps a. through d.</p> <p>(c) Replace batteries which are not functional.</p>
56				●			Power Distribution system Automatic Bus Transfer (ABT) Switching Unit	<p>a. Preliminary.</p> <p>(1) Obtain permission from engineering officer to test ABT.</p> <p>(2) Observe ship security regulations.</p>



Table 2-1. Preventive Maintenance Checks and Services

D - Daily W - Weekly M - Monthly Q - Quarterly S - Semiannually A - Annually

Item No.	Interval						Items To Be Inspected/ Serviced	Procedures
	D	W	M	Q	S	A		
56				●			<p>Power Distribution System Automatic Bus Transfer (ABT) Switching - CONT</p> <p style="text-align: center;"><u><b>ELECTRICAL SYSTEM - CONT</b></u></p> <p>(3) Notify watch standers and equipment operators that test of ABTs is being conducted and power will be momentarily interrupted.</p> <p>(4) Ensure normal and alternate/emergency power supplies are available.</p> <p>b. Test Operation of ABT.</p> <p>(1) Deenergize SSDG 1 and 2.</p> <p>(2) Ensure electrical load transfers to emergency supply.</p> <p>(3) Energize normal power supply.</p> <p>(4) Set Mode switch to MANUAL position.</p> <p>(5) Manually transfer load to normal power.</p>	

Table 2-1. Preventive Maintenance Checks and Services

D- Daily W - Weekly M - Monthly Q - Quarterly S - Semiannually A - Annually

Item No.	Interval						Items To Be Inspected/ Serviced	Procedures
	D	W	M	Q	S	A		
56				●			Power Distribution System Automatic Bus Transfer (ABT) Switching - CONT  (6) Position emergency switchboard mode switch to manual. (7) Manually transfer load to emergency power. (8) Ensure load has transferred to emergency source. (9) Set mode switch to manual position. Manually transfer power to normal. (10) Ensure power has transferred to normal source.  <p style="text-align: center;"><b>NOTE</b></p> Notify engineering officer, watch standers, and equipment operators that test of ABT is complete.  (11) Return equipment to readiness condition.	
57				●			Battery Charger  a. Deenergize circuit and tag "Out of Service - Do not Operate."  b. Disconnect battery charging cable from batteries.	

Table 2-1. Preventive Maintenance Checks and Services

D - Daily W - Weekly M - Monthly Q - Quarterly S - Semiannually A - Annually

Item No.	Interval						Items To Be Inspected/ Serviced	Procedures
	D	W	M	Q	S	A		
57				●			Battery Charger - CONT  <p style="text-align: center;"><u><b>ELECTRICAL SYSTEM - CONT</b></u></p> c. Clean and Inspect Battery Charger.  (1) Open or remove access cover.  (2) Use voltage tester to ensure electrical circuits are deenergized.  <p style="text-align: center;"><u><b>WARNING</b></u></p> High-voltage, high-capacitance components may contain voltages dangerous to life.  (3) Discharge high-voltage, high-capacitance components to electrical ground.  (4) Clean components and surface areas with vacuum cleaner; use dusting brush to clean hard-to-reach areas.  (5) Inspect components for cracked or broken parts, discoloration, or evidence of overheating.  (6) Inspect electrical and mechanical connections for tightness; use lockwashers or jamnuts to keep connections tight.	

Table 2-1. Preventive Maintenance Checks and Services

D - Daily W - Weekly M - Monthly Q - Quarterly S - Semiannually A - Annually

Item No.	Interval						Items To Be Inspected/ Serviced	Procedures
	D	W	M	Q	S	A		
57				●			Battery Charger - CONT	<p style="text-align: center;"><b><u>ELECTRICAL SYSTEM - CONT</u></b></p> <p>(7) Inspect wiring for evidence of overheating, chafing, and frayed or chipped insulation.</p> <p style="text-align: center;"><b>NOTE</b></p> <p>The brown discoloration found on silver and silver-plated contacts is harmless. Silver or silver-faced contacts should not be dressed unless sharp projections extend beyond contact surface.</p> <p>(a) Inspect battery charging cable for fraying and corrosion.</p> <p>(b) Inspect battery port connectors for deterioration.</p> <p>(c) Inspect cable plugs for corrosion, pitting, and burrs.</p>

Table 2-1. Preventive Maintenance Checks and Services

D - Daily W - Weekly M - Monthly Q - Quarterly S - Semiannually A - Annually

Item No.	Interval						Items To Be Inspected/ Serviced	Procedures
	D	W	M	Q	S	A		
57				●			<p>Battery Charger - CONT</p> <p style="text-align: center;"><b><u>ELECTRICAL SYSTEM - CONT</u></b></p> <p>d. Measure Insulation Resistance.</p> <p style="text-align: center;"><b><u>CAUTION</u></b></p> <p>Do not use a megger to measure insulation resistance of electronic control devices. Failure to observe this precaution may result in damage to rectifier units and other control elements.</p> <p>(1) Use multimeter to measure insulation resistance of charger input and output leads; minimum acceptable resistance is 1.0 megohm.</p> <p>(2) Close or reinstall access covers.</p> <p>(3) Remove safety tag; return equipment to readiness condition.</p>	

Table 2-1. Preventive Maintenance Checks and Services

D - Daily W - Weekly M - Monthly Q - Quarterly S - Semiannually A - Annually

Item No.	Interval						Items To Be Inspected/ Serviced	Procedures
	D	W	M	Q	S	A		
58						●	Distribution Panel Lighting	<p align="center"><b><u>ELECTRICAL SYSTEM - CONT</u></b></p> <p>Clean and Inspect Lighting and Power Distribution Panels.</p> <ol style="list-style-type: none"> <li>(1) Deenergize power supplies to distribution panel and tag "Out of Service - Do Not Operate."</li> <li>(2) Open or remove access covers.</li> <li>(3) Test with voltage tester to ensure electrical circuits are deenergized.</li> <li>(4) Vacuum panel; use dusting brush to loosen dirt.</li> <li>(5) Inspect electrical and mechanical fasteners; tighten loose connections. Use lockwashers or jamnuts where necessary to keep connections tight.</li> </ol> <p align="center"><b>NOTE</b></p> <p>Step (6) applies to units having spray-tight or drip-type shielding, with gasket material beneath the shield mounting bolts, to prevent the entry of liquid spray contamination within the unit.</p> <ol style="list-style-type: none"> <li>(6) Inspect the rubber/neoprene gasket material for damage, dry rot, or inadequate compression; replace if necessary.</li> </ol>

Table 2-1. Preventive Maintenance Checks and Services

D - Daily W - Weekly M - Monthly Q - Quarterly S - Semiannually A - Annually

Item No.	Interval						Items To Be Inspected/ Serviced	Procedures
	D	W	M	Q	S	A		
58						●	Distribution Panel Lighting CONT	<p align="center"><b><u>ELECTRICAL SYSTEM - CONT</u></b></p> <p>(7) Inspect fuse clips to ensure fuse retainers are in place.</p> <p>(8) Ensure overload devices are of the proper rating.</p> <p>(9) Inspect cable and component insulation for discoloration or deterioration.</p> <p>(10) Operate switches/circuit breakers to detect irregular or faulty operations.</p> <p>(11) Close or reinstall access covers.</p> <p>(12) Remove safety tags and energize power supplies.</p>
59						●	Lighting Distribution Control Centers	<p align="center"><b>NOTE</b></p> <p>Existing wiring configuration of indicating lamps or electrical interlocks on some controllers may provide a low voltage feedback circuit at auxiliary contacts when equipment power source is de-energized.</p>

Table 2-1. Preventive Maintenance Checks and Services

D - Daily W - Weekly M - Monthly Q - Quarterly S - Semiannually A - Annually

Item No.	Interval						Items To Be Inspected/ Serviced	Procedures
	D	W	M	Q	S	A		
59						●	Lighting Distribution Control Centers - CONT	<p style="text-align: center;"><b><u>ELECTRICAL SYSTEM - CONT</u></b></p> <p>Clean and Inspect Controllers.</p> <p>(1) Deenergized circuit(s) to controller and tag 'Out of Service - Do Not Operate' (Tags, Item 1, Appendix C).</p> <p>(2) Open/remove controller access cover(s).</p> <p style="text-align: center;"><b><u>WARNING</u></b></p> <p><b>Consider all electrical leads to be energized until positively proven they are deenergized.</b></p> <p>(3) Use multimeter to ensure circuits are de-energized.</p> <p>(4) Clean interior of controller with rags and dusting brush to clean hard-to-reach areas.</p> <p style="text-align: center;"><b>NOTE</b></p> <p>Where relay/contactors contacts are not accessible for visual inspection, consult supervisor to determine extent of this inspection.</p>



Table 2-1. Preventive Maintenance Checks and Services

D - Daily    W - Weekly    M - Monthly    Q - Quarterly    S - Semiannually    A - Annually

Item No.	Interval						Items To Be Inspected/ Serviced	Procedures
	D	W	M	Q	S	A		
59							<ul style="list-style-type: none"> <li>● Lighting Distribution Control Centers - CONT</li> </ul>	<p style="text-align: center;"><b><u>ELECTRICAL SYSTEM - CONT</u></b></p> <p>(5) Inspect electrical and mechanical connections for tightness.</p> <p>(6) Tighten loose connections; use jamnuts or lockwashers to keep connections tight.</p> <p>(7) Operate each manually several times; moving parts should operate freely without binding or sticking.</p> <p>(8) Close and install controller access cover(s).</p> <p>(9) Remove safety tag(s) and energize circuit(s).</p> <p>(10) Test operate controller when associated equipment can be operated.</p>

Table 2-1. Preventive Maintenance Checks and Services

D - Daily W - Weekly M - Monthly Q - Quarterly S - Semiannually A - Annually

Item No.	Interval						Items To Be Inspected/ Serviced	Procedures
	D	W	M	Q	S	A		
60						●	Automatic Bus Transfer Switch	<p align="center"><b><u>ELECTRICAL SYSTEM - CONT</u></b></p> <p>Inspect Main Control and Relay Contacts.</p> <p>(1) Obtain permission from Engineer Officer to tag ABT "Out of Service - Do Not Operate."</p> <p>(2) Notify watch standers and equipment operators involved that electric power will be secured.</p> <p>(3) Deenergize normal and alternate/emergency power supplies to ABT and timing circuit to ABT. Tag ABT "Out of Service - Do Not Operate."</p> <p>(4) Test electrical circuits; ensure they are deenergized.</p> <p>(5) Inspect main and control contacts for breaks, burns, carbonization, corrosion and pitting.</p> <p>(6) Inspect/adjust relay contacts according to component technical manual.</p> <p>(7) Remove safety tags; energize power supplies.</p> <p>(8) Test operate; inspect for proper operation.</p> <p>(9) Notify Engineer Officer, watch standers, and equipment operators ABT is in service.</p>

Table 2-1. Preventive Maintenance Checks and Services

D - Daily W - Weekly M - Monthly Q - Quarterly S - Semiannually A - Annually

Item No.	Interval						Items To Be Inspected/ Serviced	Procedures
	D	W	W	Q	S	A		
61	●						Windows	<p align="center"><b><u>DOORS, HATCHES, AND MANHOLES/WINDOWS GROUP</u></b></p> <p>a. Clean glass, using glass cleaner and soft cloths (Items 22 and 4, Appendix C).</p> <p>b. Visually inspect glass for chips or cracks.</p>
62	●						Rotary Window	<p>a. Operational Check.</p> <p>(1) Energize rotary window motor and heater.</p> <p>(2) Check for proper operation of units.</p> <p>(3) Check for plugged drain holes.</p> <p align="center"><b>NOTE</b></p> <p>If drain holes are plugged up, any leakage will remain inside the chamber and cause poor visibility, such as fogging.</p>

Table 2-1. Preventive Maintenance Checks and Services

D - Daily W - Weekly M - Monthly Q - Quarterly S - Semiannually A - Annually

Item No.	Interval						Items To Be Inspected/ Serviced	Procedures
	D	W	M	Q	S	A		
62	●						Rotary Window CONT	<p><b><u>DOORS, HATCHES, AND MANHOLES/WINDOWS GROUP</u></b></p> <p>(4) With window and heater operating, visually check to make sure that the drain holes in the bottom of the air chamber between the two glass panels are free from obstructions</p> <p>(5) If drain holes are plugged, refer to PMCS, Item 64, step a.(2) and (3).</p> <p style="text-align: center;"><b>NOTE</b></p> <p style="text-align: center;">The glass should be clean inside and out to maintain maximum visibility.</p> <p>(6) Visually check glass panels for cleanliness; if dirty see PMCS Quarterly for corrective action.</p>
63				●			Quick Action Doors	<p>a. Inspect moving parts for wear or damage.</p> <p>b. Lubricate teeth of gear sectors, racks, pinions, ratchets, pawls and cranks.</p>
64				●			Rotary Window	<p>a. Clean Glass Panels and Unplug Drain Holes.</p> <p>(1) Remove the spinning frame assembly (para. 3-194).</p> <p>(2) Using a small piece of wire, poke out any obstructions in the drain holes.</p>

Table 2-1. Preventive Maintenance Checks and Services

D - Daily W - Weekly M - Monthly Q - Quarterly S - Semiannually A - Annually

Item No.	Interval						Items To Be Inspected/ Serviced	Procedures
	D	W	M	Q	S	A		
64				●			Rotary Window - Cont	<p><b><u>DOORS, HATCHES, AND MANHOLES/WINDOWS GROUP - CONT</u></b></p> <p>(3) Be sure all the holes are completely cleaned out.</p> <p>(4) Clean glass panels with glass cleaner (Item 22, Appendix C).</p> <p>(5) Use a clean soft cloth or paper towel so as not to scratch the glass.</p> <p style="text-align: center;"><b><u>WARNING</u></b></p> <p>When assembling the unit, DO NOT bump the spinning frame assembly. This unit is dynamically balanced during manufacturing to assure proper operation and MAY SHATTER AND CAUSE INJURY if used in a damaged condition.</p> <p>(6) Assemble and install the spinning frame assembly.</p>
65					●		Watertight Doors	<p style="text-align: center;"><b>NOTE</b></p> <p>Accomplish semiannually or more frequently if necessitated by adverse conditions.</p> <p>Inspect, Clean, Lubricate, and Test Watertight Doors.</p> <p>(1) Inspect doors as indicated in steps (1)(a) through (1)(n); omit steps not applicable.</p>

Table 2-1. Preventive Maintenance Checks and Services

D - Daily W - Weekly M - Monthly Q - Quarterly S - Semiannually A - Annually

Item No.	Interval						Items To Be Inspected/ Serviced	Procedures
	D	W	M	Q	S	A		
65					●		Watertight Doors - Cont	<p><b><u>DOORS, HATCHES, AND MANHOLES/WINDOWS GROUP - CONT</u></b></p> <p>(a) Loose, missing and damaged parts, or parts showing excessive wear or corrosion.</p> <p>(b) Paint, rust, and other foreign matter on gaskets, knife-edges, wedge pads, and working parts.</p> <p>(c) Binding and difficult operation instead of smooth and positive action.</p> <p>(d) Distortion and deterioration of metal surfaces.</p> <p>(e) Hinge pin wear; ensure pins are properly secured.</p> <p>(2) Clean door assembly knife edge and gasket as indicated below:</p> <p>(a) Clean steel knife-edge, if applicable, with aluminum oxide abrasive cloth, grit number 320 (Item 24, Appendix C), only if paint or rust is present and use clean rag (Item 14, Appendix C) to remove any abrasive grit remaining on knife-edge.</p>

Table 2-1. Preventive Maintenance Checks and Services

D - Daily W - Weekly M - Monthly Q - Quarterly S - Semiannually A - Annually

Item No.	Interval						Items To Be Inspected/ Serviced	Procedures
	D	W	M	Q	S	A		
65					●		Watertight Doors CONT	<p><b><u>DOORS, HATCHES, AND MANHOLES/WINDOWS GROUP - CONT</u></b></p> <p><b><u>CAUTION</u></b></p> <p>Do not use abrasive cloth to clean aluminum knife-edges under any circumstances.</p> <p>(b) Clean (Item 28, Appendix C) any aluminum knife-edges with paint remover if paint and similar substances are present. Use clean rag to dry knife-edge after cleaning.</p> <p><b><u>CAUTION</u></b></p> <p>Under no circumstances should a wire brush or metal scraper be used to clean the rubber gasket.</p> <p>(c) Clean all paint and rust from rubber gasket by scraping with hardwood block or rubber eraser (Items 10 and 27, Appendix C); or, if gasket condition is unsatisfactory (per step (1)(f) above), accomplish steps (3) through (6) as indicated.</p>

Table 2-1. Preventive Maintenance Checks and Services

D - Daily W - Weekly M - Monthly Q - Quarterly S - Semiannually A - Annually

Item No.	Interval						Items To Be Inspected/ Serviced	Procedures
	D	W	M	Q	S	A		
65					●		Watertight Doors CONT	<p><b><u>DOORS, HATCHES, AND MANHOLES/WINDOWS GROUP - CONT</u></b></p> <p style="text-align: center;"><b>NOTE</b></p> <p>After inspection and cleaning procedures indicated above have been completed, the following restoration measures should be accomplished to the degree inspection indicates necessary.</p> <p>(3) Remove old gasket and clean gasket coaming with wire brush (Item 29, Appendix C) until bare metal is exposed.</p> <p>(4) Apply one coat of formula 150 primer and two topcoat5 of formula 151 or equivalent paint (Items 30 and 31, Appendix C). Take care not to paint knife-edges.</p> <p>(5) Install new gasket (if removed in step (3)).</p> <p style="padding-left: 20px;">(a) Measure and cut new gasket.</p>



Table 2-1. Preventive Maintenance Checks and Services

D - Daily W - Weekly M - Monthly Q - Quarterly S - Semiannually A - Annually

Item No.	Interval						Items To Be Inspected/ Serviced	Procedures
	D	W	M	Q	S	A		
65					●		Watertight Doors CONT	<p><b><u>DOORS, HATCHES, MANHOLES/WINDOWS GROUP - CONT</u></b></p> <p><b>NOTE</b></p> <p>Because gasket will shrink with age, it should be cut several inches over size (approximately 1 inch extra for every 3 feet of channel).</p> <p>(b) Install gasket in channel and let set for approximately 24 hours to allow for shrinkage.</p> <p>(c) Remove gasket and trim excess material.</p> <p><b>NOTE</b></p> <p>Allow 1 inch extra for compressing gasket in channel.</p> <p><b>NOTE</b></p> <p>A 45° joint should be used at corners in closures with square corners. Elsewhere, square butt joints are preferable. Joints should not be located in radius portions of closures. The number of gasket joints should be kept to a minimum (no more than 4). Very short strips (less than 2 feet) should not be used.</p>

Table 2-1. Preventive Maintenance Checks and Services

D - Daily W - Weekly M - Monthly Q - Quarterly S - Semiannually A - Annually

Item No.	Interval						Items To Be Inspected/ Serviced	Procedures
	D	W	M	Q	S	A		
65					●		<p>Watertight Doors CONT</p> <p>(d) Apply sealing compound (Item 32, Appendix C) to back of gasket and install gasket in channel.</p> <p>(e) Clean old grease and foreign matter from threaded and exposed working parts with cleaning solvent (Item 15A, Appendix C).</p> <p>(6) Lubrication procedures.</p> <p style="text-align: center;"><b><u>CAUTION</u></b></p> <p>Ensure oil or petroleum grease does not contact gaskets.</p> <p style="text-align: center;"><b>NOTE</b></p> <p>Operating handle or dog-spindles that penetrate through watertight closure frames or panels should not have grease fittings, in lieu of stick-packing plungers, for accomplishing packing of the spindle. A through spindle packed with general purpose grease is not watertight; therefore, grease fittings must be used only on non-penetrating spindles.</p>	

Table 2-1. Preventive Maintenance Checks and Services

D - Daily W - Weekly M - Monthly Q - Quarterly S - Semiannually A - Annually

Item No.	Interval						Items To Be Inspected/ Serviced	Procedures
	D	W	M	Q	S	A		
65					●		Watertight Doors CONT	<p><b><u>DOORS, HATCHES, AND MANHOLES GROUP - CONT</u></b></p> <p>(a) Screw packing plunger several turns to force existing lubricating stick packing out and around spindle. If stickpacking has been completely used up, the packing plunger will not screw in any further and stick packing (Item 33, Appendix C) must be replenished as follows:</p> <ol style="list-style-type: none"> <li><u>1</u> Remove packing plunger from spindle.</li> <li><u>2</u> Insert stick packing in shaft opening.</li> <li><u>3</u> Push stick packing deep into shaft opening using a 1/4-inch diameter rod.</li> <li><u>4</u> Reinsert packing plunger in packing shaft opening.</li> <li><u>5</u> Tighten plunger with a screwdriver until excess packing appears around spindle.</li> </ol> <p>(b) Inject grease (Item 34, Appendix C) through grease fittings, if installed, until grease appears around spindle of dogging mechanism that does not penetrate the watertight boundary.</p>

Table 2-1. Preventive Maintenance Checks and Services

D - Daily W - Weekly M - Monthly Q - Quarterly S - Semiannually A - Annually

Item No.	Interval						Items To Be Inspected/ Serviced	Procedures
	D	W	M	Q	S	A		
65					●		Watertight Doors CONT	<p><u>DOORS, HATCHES, AND MANHOLES/WINDOWS GROUP - CONT</u></p> <p><b>NOTE</b></p> <p>If dog or handlever shafts tend to freeze, disassemble, clean, and lubricate with a light coat of grease, replace the string packing between the coils of the compression spring on the dog spindle, reassemble and adjust. See Watertight Door Dog Diagram.</p> <p>(c) Apply a light coat of grease to threaded dogs and shaft. Turn dog nuts through entire threaded length to ensure smooth operation.</p> <p>(d) Lubricate remaining working parts and surfaces with grease, stick packing, or with a few drops of oil, as applicable.</p>

Table 2-1. Preventive Maintenance Checks and Services

D - Daily W - Weekly M - Monthly Q - Quarterly S - Semiannually A - Annually

Item No.	Interval						Items To Be Inspected/ Serviced	Procedures
	D	W	M	Q	S	A		
65					●		Watertight Doors CONT	<p><u>DOORS, HATCHES, AND MANHOLES/WINDOWS GROUP - CONT</u></p> <p>DOG SLEEVE KNIFE EDGE DOOR FRAME SET SCREW DOG LEVER PACKING PLUNGER DOOR DOG ASSEMBLY (CROSS SECTION VIEW)</p> <p>Legend:          ↑ PATH OF PACKING          ○ POINTS AT WHICH EXCESS PACKING APPEARS</p>

Watertight Door Dog Diagram.

Table 2-1. Preventive Maintenance Checks and Services

D - Daily W - Weekly M - Monthly Q - Quarterly S - Semiannually A - Annually

Item No.	Interval						Items To Be Inspected/ Serviced	Procedures
	D	W	M	Q	S	A		
65					●		Watertight Doors CONT	<p><b><u>DOORS, HATCHES, AND MANHOLES/WINDOWS GROUP - CONT</u></b></p> <p>(e) Remove excess lubricant.</p> <p>(7) Test procedure.</p> <p>(a) Use chalk test procedure for standard closures with slab-gasket/knife-edge/bevel-edge seal.</p> <p><u>1</u> Rub chalk on door knife edge.</p> <p><u>2</u> Close and dog closure tightly. The gasket should seat tightly on mating surface around entire closure.</p> <p><u>3</u> Open closure and inspect imprint of chalk on gasket. If chalk line is not continuous, closure is not watertight and requires adjustment or repair.</p> <p><b><u>CAUTION</u></b></p> <p>Compression of the gasket should not exceed 1/8-inch. Excess compression will damage the gasket.</p>

Table 2-1. Preventive Maintenance Checks and Services

D - Daily W - Weekly M - Monthly Q - Quarterly S - Semiannually A - Annually

Item No.	Interval						Items To Be Inspected/ Serviced	Procedures
	D	W	M	Q	S	A		
65					●		Watertight Doors CONT	<p><b><u>DOORS, HATCHES, AND MANHOLES/WINDOWS GROUP - CONT</u></b></p> <p><u>4</u> Increase compression on the gasket in area of no contact by adjusting nearest dog or hinge, by tightening dog spindle adjustment nuts, or hinge pin positioning set screw on an airtight door. In order to obtain satisfactory seating on airtight-doors, since they are fitted with "bound" hinges, it may be necessary to back off on tightness of hinge edge when dog edge of door is adjusted tighter.</p> <p><u>5</u> Repeat steps (7)(a)<u>1</u> through (7)(a)<u>4</u> and make the proper adjustments until chalk imprint is continuous.</p> <p><u>6</u> Apply a light coat of silicone compound to gasket.</p> <p>(b) Operate closure through full cycle of operation several times to ensure smooth and positive dogging action.</p>

Table 2-1. Preventive Maintenance Checks and Services

D - Daily W - Weekly M - Monthly Q - Quarterly S - Semiannually A - Annually

Item No.	Interval						Items To Be Inspected/ Serviced	Procedures
	D	W	M	Q	S	A		
66					●		<p><u>DOORS/HATCHES AND MANHOLES/WINDOWS GROUP - CONT</u></p> <p>a. Check for the following problems during inspection of emergency escape scuttles:</p> <ul style="list-style-type: none"> <li>(1) Jammed in closed position.</li> <li>(2) Will only partially open.</li> <li>(3) Material stacked on top of scuttle preventing opening of scuttle.</li> <li>(4) Hinge pins severely corroded and hard to operate.</li> <li>(5) Locking arm adrift or inoperative.</li> <li>(6) Scuttle will not lock in an open position.</li> <li>(7) Recessed area of scuttle is full of dirt, debris, water and miscellaneous material that blocks operation of hinge pins.</li> <li>(8) Access to scuttle blocked by furniture or jury-rigged clothing hangers.</li> <li>(9) T-wrench missing.</li> </ul> <p>b. Inspect, Clean, Lubricate, and Test Watertight Hatches and Scuttles.</p>	



Table 2-1. Preventive Maintenance Checks and Services

D - Daily W - Weekly M - Monthly Q - Quarterly S - Semiannually A - Annually

Item No.	Interval						Items To Be Inspected/ Serviced	Procedures
	D	W	M	Q	S	A		
66					●		<p><b><u>DOORS, HATCHES, AND MANHOLES/WINDOWS GROUP - CONT</u></b></p> <p>(1) Inspect hatches and scuttles for:</p> <ul style="list-style-type: none"> <li>(a) Loose, missing, and damaged parts.</li> <li>(b) Paint, rust, and other foreign matter on gaskets, knife-edges, and working parts.</li> <li>(c) Binding and difficult operation.</li> <li>(d) Distortion and deterioration of metal surfaces.</li> <li>(e) Hinge pin wear; ensure pins are properly secured.</li> <li>(f) Gasket for cracks, deterioration, hardness, permanent set over 1/8-inch deep, and gaps due to shrinkage where gasket ends meet.</li> <li>(g) Unobstructed access to escape scuttles.</li> </ul> <p>(2) Clean steel knife-edges with abrasive cloth only if paint or rust are present, use clean rags to remove any abrasive grit remaining on knife-edges.</p> <p style="text-align: center;"><b><u>CAUTION</u></b></p> <p style="text-align: center;">Do not use abrasive cloth to clean aluminum knife-edges under any circumstances.</p>	

Table 2-1. Preventive Maintenance Checks and Services

D - Daily W - Weekly M - Monthly Q - Quarterly S - Semiannually A - Annually

Item No.	Interval						Items To Be Inspected/ Serviced	Procedures
	D	W	M	Q	S	A		
66					●		Watertight Hatches and Scuttles CONT	<p><b><u>DOORS, HATCHES, AND MANHOLES/WINDOWS GROUP- CONT</u></b></p> <p>(3) Clean any aluminum knife-edges with paint remover (Item 28, Appendix C), if paint or similar substance is present. Use clean rag to dry knife edges after cleaning.</p> <p>(4) Clean gaskets by scraping with hardwood block, or rubber eraser.</p> <p>(5) Clean debris from flush hatch and scuttle recesses, if applicable.</p> <p>(6) Clean old grease and foreign matter from threaded and exposed working parts.</p> <p>(7) Remove gasket if any condition in step a.(6) exists, or if the closure panel required painting.</p> <p style="text-align: center;"><b><u>WARNING</u></b></p> <p><b>Wear safety goggles when using wire brush.</b></p> <p>(8) Using wire brush, clean corroded areas until bare metal is exposed.</p> <p>(9) Apply one coat of formula 150 primer and two topcoats of formula 151 or equivalent paint (Items 30 and 31, Appendix C). Take care not to paint knife-edges or gaskets.</p> <p>(10) Install new gasket (if removed in step (b)(7)).</p>

Table 2-1. Preventive Maintenance Checks and Services

D - Daily W - Weekly M - Monthly Q - Quarterly S - Semiannually A - Annually

Item No.	Interval						Items To Be Inspected/ Serviced	Procedures
	D	W	M	Q	S	A		
66					●		Watertight Hatches and Scuttles CONT	<p><b><u>DOORS, HATCHES, AND MANHOLES/WINDOWS GROUP - CONT</u></b></p> <p>(a) Measure and cut new gasket.</p> <p style="text-align: center;"><b>NOTE</b></p> <p>Because gasket will shrink with age, it should be cut several inches over size approximately 1 inch extra for every 3 feet of channel.</p> <p>(b) Install gasket in channel and let set for approximately 24 hours to allow for shrinkage.</p> <p>(c) Remove gasket and trim excess material.</p> <p style="text-align: center;"><b>NOTE</b></p> <p>Allow 1 inch extra for compressing gasket in channel.</p>

Table 2-1. Preventive Maintenance Checks and Services

D - Daily W - Weekly M - Monthly Q - Quarterly S - Semiannually A - Annually

Item No.	Interval						Items To Be Inspected/ Serviced	Procedures
	D	W	M	Q	S	A		
66					●		Watertight Hatches and Scuttles CONT	<p><b><u>DOORS, HATCHES, AND MANHOLES/WINDOWS GROUP - CONT</u></b></p> <p><b>NOTE</b></p> <p>A 45° joint should be used at corners in closures with square corners. Elsewhere, square butt joints are preferable. Joints should not be located in radius portions of closures. The number of gasket joints should be kept to a minimum (no more than 4). Very short strips (less than 3 feet) should not be used.</p> <p>(d) Apply sealing compound (Item 32, Appendix C) to back of gasket and install gasket in channel.</p> <p><b><u>CAUTION</u></b></p> <p>Ensure oil or grease does not contact gaskets.</p> <p>(11) Apply wire rope grease, MIL-G-18458, to the hinge blocks, brace link, and surrounding areas, if applicable.</p>

Table 2-1. Preventive Maintenance Checks and Services

D - Daily W - Weekly M - Monthly Q - Quarterly S - Semiannually A - Annually

Item No.	Interval						Items To Be Inspected/ Serviced	Procedures
	D	W	M	Q	S	A		
66					●		Watertight Hatches and Scuttles CONT	<p><b><u>DOORS, HATCHES, AND MANHOLES/WINDOWS GROUP - CONT</u></b></p> <p><b>NOTE</b></p> <p>Operating handle or dog-spindles that penetrate through watertight closure frames or panels should not have grease fittings, in lieu of stick-packing plungers, for accomplishing packing of the spindle. A through spindle packed with general purpose grease is not watertight; therefore, grease fittings must be used only on non-penetrating spindles.</p> <p>(12) Lubricate dog or handwheel shafts:</p> <p>(a) Screw packing plunger several turns to force existing lubricating stick packing out and around spindle. If stick packing has been completely used up, the packing plunger will not screw in any further and stick packing (Item 33, Appendix C) must be replenished as follows:</p> <ol style="list-style-type: none"> <li>1 Remove packing plunger from spindle.</li> <li>2 Insert stick packing in shaft opening.</li> <li>3 Push stick packing deep into shaft opening using a 1/4-inch diameter rod.</li> </ol>

Table 2-1. Preventive Maintenance Checks and Services

D - Daily W - Weekly M - Monthly Q - Quarterly S - Semiannually A - Annually

Item No.	Interval						Items To Be Inspected/ Serviced	Procedures
	D	W	M	Q	S	A		
66					●		<p><b><u>DOORS, HATCHES, AND MANHOLES/WINDOWS GROUP - CONT</u></b></p> <p>4 Reinsert packing plunger in packing shaft opening.</p> <p>5 Tighten plunger with a screwdriver until excess packing appears around spindle.</p> <p>(b) If dogging mechanism does not penetrate the watertight boundary and is equipped with grease fittings, inject grease MIL-G-23549, until grease appears around spindle.</p> <p>NOTE</p> <p>If dog, handwheel, or handlever shafts tend to freeze, disassemble, clean and lubricate with a light coat of grease, MIL-G-23549, reassemble and adjust.</p> <p>(13) Apply a light coat of grease to threaded dogs and shafts. Turn dog nuts through entire threaded length to ensure smooth operation.</p> <p>(14) Lubricate remaining working parts and surfaces through grease fittings, with stick packing, or with a few drops of oil, as applicable.</p> <p>(15) Remove excess lubricant.</p>	

Table 2-1. Preventive Maintenance Checks and Services

D - Daily W - Weekly M - Monthly Q - Quarterly S - Semiannually A - Annually

Item No.	Interval						Items To Be Inspected/ Serviced	Procedures
	D	W	M	Q	S	A		
66					●		<p>Watertight Hatches and Scuttles CONT</p> <p><b><u>DOORS, HATCHES, AND MANHOLES/WINDOWS GROUP - CONT</u></b></p> <p>(a) Rub chalk on knife-edge.</p> <p>(b) Close and dog closure tightly. The gasket should seal tightly on knife-edge around entire periphery.</p> <p style="text-align: center;"><b><u>CAUTION</u></b></p> <p>Compression of the gasket should not exceed 1/8-inch. Excess compression will damage the gasket.</p> <p>(c) Open closure and observe imprint of chalk on gasket. If chalk line is not continuous, closure is not watertight and required adjustment or repair.</p> <p>(16) Apply a light coat of silicone compound, MIL-S-8660, to gasket.</p> <p>(17) Operate closure through full cycle of operation several times to ensure smooth and positive dogging action.</p> <p>(18) Inspect safety devices for the following as applicable:</p> <p>(a) Cracked or broken welds.</p>	

Table 2-1. Preventive Maintenance Checks and Services

D - Daily W - Weekly M - Monthly Q - Quarterly S - Semiannually A - Annually

Item No.	Interval						Items To Be Inspected/ Serviced	Procedures
	D	W	M	Q	S	A		
66					●		Watertight Hatches and Scuttles CONT	<p><b><u>DOORS, HATCHES, AND MANHOLES/WINDOWS GROUP - CONT</u></b></p> <p>(b) Missing or damaged safety arms.</p> <p>(c) Proper operation and condition of safety latches.</p> <p>(d) Proper installation of toggle pin/bolts and chains.</p> <p>(e) Proper installation and condition of safety stanchions and lifelines/rails.</p>
67						●	Rotary Window	<p>Check Motor Brushes.</p> <p><b><u>WARNING</u></b></p> <ul style="list-style-type: none"> <li>● This clear-view screen is an electrically operated device. Disconnect this device from the ship's power source before servicing either the control box or the screen unit.</li> <li>● Caution should be exercised if this unit has been in continuous operation for an extended period of time. High operating temperatures could be present and burns could result.</li> </ul>



Table 2-1. Preventive Maintenance Checks and Services

D - Daily W - Weekly M - Monthly Q - Quarterly S - Semiannually A - Annually

Item No.	Interval						Items To Be Inspected/ Serviced	Procedures
	D	W	M	Q	S	A		
67						●	Rotary Window CONT	<p><u>DOORS, HATCHES, AND MANHOLES/WINDOWS GROUP - CONT</u></p> <ol style="list-style-type: none"> <li>(1) Disconnect electrical connector from top of junction box.</li> <li>(2) Remove back cover and slotted head screws. Pull cover off motor.</li> <li>(3) Unscrew brush caps located on opposite sides of motor and pull brushes out of their holders.</li> <li>(4) Replace brushes when the carbon is less than 1/4-inch long.</li> <li>(5) Wipe off all dust and residue from brushes and brush holders before reassembly.</li> <li>(6) Insert brushes into holders.</li> <li>(7) Screw in brush caps.</li> <li>(8) Install cover on motor and secure with screws.</li> <li>(9) Connect electrical connector on the top of the junction box.</li> <li>(10) Energize motor and check for proper operation.</li> </ol>

Table 2-1. Preventive Maintenance Checks and Services

D - Daily W - Weekly M - Monthly Q - Quarterly S - Semiannually A - Annually

Item No.	Interval						Items To Be Inspected/ Serviced	Procedures
	D	W	M	Q	S	A		
68		●					Toggle Assembly	<p style="text-align: center;"><u>LASHING GEAR EQUIPMENT</u></p> <p>a. Inspect toggle assembly for dirt and grease buildup.</p> <p>b. If toggle assembly is not in use operate to verify freedom of movement.</p> <p>c. If freedom of movement is restricted see PMCS monthly for corrective action.</p>
69			●				Toggle Assembly	<p>a. Clean old grease and foreign matter from exposed working parts with cleaning solvent (Item 15A, Appendix C) or kerosene.</p> <p>b. Lubricate exposed working parts with wire rope grease, MIL-G-18458.</p> <p>c. If toggle assembly is not in use, operate assembly to spread lubricant on moving parts.</p>
70	●						Workboat	<p style="text-align: center;"><u>WORKBOAT, LIFEBOATS/DAVITS</u></p> <p>Visually inspect the inflatable workboat for leaks, loose fittings, or broken and damaged parts.</p>
71	●						Outboard Motor	<p>a. Visually inspect the outboard motor, particularly the steering and throttle controls and the shift lever, for leaking fluid, loose connections, loose cowling, and broken parts. Ensure mounting clamps are secure and tightened to provide a solidly mounted motor.</p>

Table 2-1. Preventive Maintenance Checks and Services

D- Daily W - Weekly M - Monthly Q - Quarterly S - Semiannually A - Annually

Item No.	Interval						Items To Be Inspected/ Serviced	Procedures
	D	W	M	Q	S	A		
71	●						Outboard Motor CONT	<p align="center"><u>WORKBOAT, LIFEBOATS/DAVITS - CONT</u></p> <p>b. Visually inspect the canister for cracks.</p> <p>c. Drain and flush cooling system after every use.</p>
72	●						Crane	<p>a. Visually inspect the crane assembly for cracks in the base and boom. Look for loose connections to the motor assembly. Inspect the block for frayed wire rope, loose or bent plates, and wobbly sheaves.</p> <p>b. Inspect the winch assembly base for loose bolts, loose, or cracked, bent, or deformed connections.</p>
73		●					Workboat	<p>a. Check for holes, punctures or tears. Repair with repair kit.</p> <p>b. Check for cleanliness. Wash with water and normal household detergent.</p> <p>c. Hose down with fresh water.</p>
74		●					Outboard Motor	<p>a. Check exterior of motor for scratches or deformation.</p> <p>b. Check throttle grip for smooth operation.</p> <p>c. Check shift handle for smooth operation.</p> <p>d. Check tilt lever for proper operation.</p>

Table 2-1. Preventive Maintenance Checks and Services

D - Daily W - Weekly M - Monthly Q - Quarterly S - Semiannually A - Annually

Item No.	Interval						Items To Be Inspected/ Serviced	Procedures
	D	W	M	Q	S	A		
75			●				Davits	<p style="text-align: center;"><u>WORKBOAT, LIFEBOATS/DAVITS</u></p> <p>Inspect for security, corrosion and loose or frayed cable.</p>
76				●			Outboard Motor	<p>a. Clean and adjust spark plug. (Cap 0.020-0.024 in.)</p> <p>b. Remove drain plug and vent plug to drain oil. Replace plugs. Refill with two-cycle outboard motor oil.</p> <p>c. Check cooling system.</p> <p>d. Disconnect inlet and filter to pump fuel lines from fuel filter. Remove nut and washer and remove filter assembly. Clean or replace fuel filter.</p> <p>e. Clean fuel tank.</p>
77						●	Workboat	<p>a. Inspect the container for bad dents or signs of damage in the corners.</p> <p>b. Check the container lip for cracks, especially around the painter outlet and where the container bands go around.</p> <p>c. If the container is damaged badly enough to leak water or likely to leak during the next 12 months, it should be repaired or replaced.</p> <p>d. Check the condition of the nameplate and labels and replace if necessary. All printing and stamping should be legible.</p> <p>e. Inspect the condition of the container seal.</p>

Table 2-1. Preventive Maintenance Checks and Services

D - Daily W - Weekly M - Monthly Q - Quarterly S - Semiannually A - Annually

Item No.	Interval						Items To Be Inspected/ Serviced	Procedures
	D	W	M	Q	S	A		
78	●						Ship Service/Emergency Switchboard	<p align="center"><u>CONTROL CENTERS/SWITCHBOARDS</u></p> <p align="center"><b>NOTE</b></p> <p>Maintenance procedures for the Ship Service and Emergency Generator Switchboards are the same.</p> <p>Ground Detection Test.</p> <p>(1) Depress GND DETECTION TEST pushbutton.</p> <p>(2) Observe GND DETECTION LIGHTS. If any phase is grounded that lamp will extinguish and the remaining lamps will glow at full brilliance. When no phase is grounded all three lamps will glow at half brilliance.</p>
79	●						Motor Control Centers	<p align="center"><u>WARNING</u></p> <p>All compartments may contain hazardous voltages. Use CAUTION when checking equipment to prevent equipment damage, personal injury, or electrocution.</p>

Table 2-1. Preventive Maintenance Checks and Services

D - Daily W - Weekly M - Monthly Q - Quarterly S - Semiannually A - Annually

Item No.	Interval						Items To Be Inspected/ Serviced	Procedures
	D	W	M	Q	S	A		
79	●						Motor Control Centers CONT  <p style="text-align: center;"><b>CONTROL CENTERS/SWITCHBOARDS</b></p> <p style="text-align: center;"><b>NOTE</b></p> <p style="text-align: center;">Maintenance procedures for all motor control centers are the same.</p> <p>a. Visual Inspection. Look for indications of overheating, arcing, or insulation breakdown.</p> <p>b. Physical Inspection.</p> <p>(1) Feel the doors, enclosure sides, and deadfront, surfaces of switches with the palm of the hand.</p> <p>(2) Any surface with a temperature which the palm of the hand cannot stand for about 3 seconds indicates trouble.</p> <p>(3) Shut motor controller down immediately and repair or replace as necessary.</p>	
80		●					Ship Service/ Emergency Switchboard  <p style="text-align: center;"><b>NOTE</b></p> <p style="text-align: center;">Maintenance procedures for the Ship Service and Emergency Generator Switchboards are the same.</p> <p>Visual Inspection. Visually check fuses, indicating lamps, meters, wiring, terminal connections, loose or damaged components, and general interior and exterior appearance of switchboard.</p>	

Table 2-1. Preventive Maintenance Checks and Servicer

D - Daily W - Weekly M - Monthly Q - Quarterly S - Semiannually A - Annually

Item no.	Interval						Items To Be Inspected/ Serviced	Procedures
	D	W	M	Q	S	A		
81		•					<p>Motor Control Centers</p> <p style="text-align: center;"><u>CONTROL CENTERS/SWITCHBOARDS - CONT</u></p> <p style="text-align: center;">NOTE</p> <p style="text-align: center;">Maintenance procedures for all motor control centers are the same.</p> <p>a. Visual Inspection.</p> <p style="padding-left: 40px;">Visual Inspection.</p> <p style="padding-left: 80px;">(1) Inspect interlock switch handle, controller switches, and light lenses for cracks, breakage, and damage. Replace as required.</p> <p style="padding-left: 80px;">(2) Pull down switch handle and padlock.</p> <p style="padding-left: 80px;">(3) Turn panel door screws 1/4 turn counterclockwise.</p> <p style="padding-left: 80px;">(4) Swing panel door left to open.</p> <p style="padding-left: 80px;">(5) Inspect transformer for damage, loose or broken wires, and frayed or burnt wires. Replace as required.</p> <p style="padding-left: 80px;">(6) Inspect interlock switch for damage, loose or broken wires, burnt contacts or frayed or burnt wires. Replace as required.</p>	

Table 2-1. Preventive Maintenance Checks and Services

D - Daily W - Weekly M - Monthly Q - Quarterly S - Semiannually A - Annually

Item No.	Interval						Items To Be Inspected/ Serviced	Procedures
	D	W	M	Q	S	A		
81		•					Motor Control Centers CONT	<p align="center"><u>CONTROL CENTERS/SWITCHBOARDS - CONT</u></p> <p>(7) Inspect controllers for damage, loose, broken, frayed or burnt wires. Replace as required.</p> <p>(8) Inspect fuse cartridges for damage. Replace as required.</p>
82			•				Ship Service/ Emergency Switchboard	<p align="center">NOTE</p> <p>Maintenance procedures for the Ship Service and Emergency Generator Switchboards are the same.</p> <p>a. Verify Operation.</p> <p>(1) Operate switchboard in accordance with (TM 55-1905-223-10) to ensure proper function of components.</p> <p>(2) Repair or replace defective components as necessary.</p>



Table 2-1. Preventive Maintenance Checks and Services

D - Daily W - Weekly M - Monthly Q - Quarterly S - Semiannually A - Annually

Item No.	Interval						Items To Be Inspected/ Serviced	Procedures
	D	W	M	Q	S	A		
83			•				Motor Control Centers	<p style="text-align: center;"><u>CONTROL CENTERS/SWITCHBOARDS - CONT</u></p> <p style="text-align: center;">NOTE</p> <p>Maintenance procedures for all Motor Control Centers are the same.</p> <p>a. Verify Operation.</p> <p style="padding-left: 40px;">(1) Operate Motor Controller in accordance with (TM 55-1905-223-10) to ensure proper function of components.</p> <p style="padding-left: 40px;">(2) Repair or replace defective components as necessary.</p>
84			•					<p>a. Visually inspect circuit breaker, switches, and lenses for cracks, breakage, and damage. Replace as required.</p> <p>b. Visually inspect circuit breaker for damage, loose or broken wires, and frayed or burnt wires. Replace as required.</p> <p>c. Visually inspect transformer for damage, loose or broken wires, and frayed or burnt wires. Replace as required.</p> <p>d. Visually inspect fuse cartridges for damage. Replace as required.</p> <p>e. Visually inspect motor starter for damage, loose or broken wires, and frayed or burnt wires, or burnt contacts.</p>

Table 2-1. Preventive Maintenance Checks and Services

D - Daily W - Weekly M - Monthly Q - Quarterly S - Semiannually A - Annually

Item no.	Interval						Items To Be Inspected/ Serviced	Procedures
	D	W	M	Q	S	A		
85				•			<p style="text-align: center;"><u>CONTROL CENTERS/SWITCHBOARDS - CONT</u></p> <p style="text-align: center;"><u>CAUTION</u></p> <p>Circuit breaker must be "OFF" before opening door.</p> <p>a. Turn off circuit breakers.</p> <p>b. Turn panel door fasteners 1/4 turn counterclockwise.</p> <p>c. Swing panel door left to open.</p> <p>d. Remove associated circuit breaker for damage, loose or broken wires, and frayed or burnt wires. Replace as required.</p>	
86						•	<p>Ship Service/Emergency Switchboard</p> <p>a. Preliminary.</p> <p style="text-align: center;"><u>WARNING</u></p> <p>Wire air starting inlet valve shut and tag "Out of Service - Do Not Open."</p> <p>(1) Ensure SSDG supply switches are open and tag "Out of Service - Do Not Operate."</p>	

Table 2-1. Preventive Maintenance Checks and Services

D - Daily W - Weekly M - Monthly Q - Quarterly S - Semiannually A - Annually

Item No.	Interval						Items To Be Inspected/ Serviced	Procedures
	D	W	M	Q	S	A		
86							<ul style="list-style-type: none"> <li>● Ship Service/Emergency Switchboard - CONT</li> </ul>	<p align="center"><u>CONTROL CENTERS/SWITCHBOARDS - CONT</u></p> <p>(2) De-energize remote control, remote indicating light, and meter circuits on associated switchboards. Tag "Out of Service - Do Not Operate."</p> <p>(3) De-energize switchboard-mounted control switches and tag "Out of Service - Do Not Operate."</p> <p>(4) Ensure each end of bus tie circuit breakers is open and tag "Out of Service - Do Not Operate."</p> <p align="center">NOTE</p> <p>This maintenance is best performed at night in port. Rig temporary lighting.</p> <p>b. Clean and Inspect Switchboard and Switchboard Equipment, as follows:</p> <p>(1) Open or remove access covers.</p> <p align="center"><u>WARNING</u></p> <p>Wear 5000/7000-volt rubber gloves and have safety personnel standing by.</p>

Table 2-1. Preventive Maintenance Checks and Services

D - Daily W - Weekly M - Monthly Q - Quarterly S - Semiannually A - Annually

Item no.	Interval						Items To Be Inspected/ Serviced	Procedures
	D	W	M	Q	S	A		
86						•	<p>Ship Service/Emergency Switchboard - CONT</p> <p>(2) Use multimeter to test all bus bars, circuit breakers, and cable connections to ensure all power supplies are de-energized.</p> <p>(3) Vacuum all components. Use dusting brush to loosen dirt.</p> <p>(4) Wipe all components with clean, lint-free rags (NSN 7920-00-205-3570).</p> <p>(5) Inspect all electrical and mechanical fastenings and tighten loose connections. use lockwashers on jam nuts, where necessary, to keep connections tight.</p> <p>(6) Ensure that all moving parts are free to function.</p> <p>(7) Inspect all contacts for pitting, rough spots, and proper seating. Dress with sandpaper if necessary.</p> <p>(8) Inspect the support of bus bars. Ensure that these supports will prevent striking of bus bars or grounded parts during periods of shock.</p> <p>(9) Lubricate (sparingly) bearing points on circuit breakers and rheostats. Wipe off excess oil (MIL-G-23827).</p>	

Table 2-1. Preventive Maintenance Checks and Services

D - Daily W - Weekly M - Monthly Q - Quarterly S - Semiannually A - Annually

Item No.	Interval						Items To Be Inspected/ Serviced	Procedures
	D	W	M	Q	S	A		
86						•	Ship Service/Emergency Switchboard - CONT	<p align="center"><u>CONTROL CENTERS/SWITCHBOARDS - CONT</u></p> <p>(10) Inspect for frayed, chipped, cracked or burnt insulation. Touch up with air-drying varnish, where necessary (MIL-E-15090).</p> <p align="center">NOTE</p> <p align="center">Never apply varnish to a dirty surface. Avoid building up excess varnish.</p> <p>(11) Ensure no loose items are left inside switchboard.</p> <p>(12) Close or reinstall access covers.</p> <p>(13) Remove wire or reconnect starting motor, as applicable.</p> <p>(14) Remove all tags; set up switchboard and perform operational checks per TM 55-1905-223-10.</p>
87						•	Ship Service/Emergency Switchboard Draw-Out Circuit Breakers	<p>a. Preliminary.</p> <p align="center">NOTE</p> <p align="center">Maintenance procedures for Ship Service and Emergency Generator switchboards are the same.</p>

Table 2-1. Preventive Maintenance Checks and Services

D - Daily W - Weekly M - Monthly Q - Quarterly S - Semiannually A - Annually

Item No.	Interval						Items To Be Inspected/ Serviced	Procedures
	D	W	M	Q	S	A		
87							<ul style="list-style-type: none"> <li>Ship Service/Emergency Switchboard Draw-Out Circuit Breakers - CONT</li> </ul>	<p align="center"><u>CONTROL CENTERS/SWITCHBOARDS - CONT</u></p> <p>(1) Ensure that emergency generator is not in operation.</p> <p align="center"><u>WARNING</u></p> <p>Voltages dangerous to life exist when equipment is open and energized. Do not work alone.</p> <p align="center"><u>CAUTION</u></p> <p>Before inspection or any maintenance work is done, be sure that the breaker is in the open position. All electrical power, both primary and control sources, should also be disconnected.</p> <p>(2) Deenergize circuit breaker.</p> <p>(3) Periodic inspection of the circuit breaker is recommended at least once a year. More frequent inspections are recommended if severe load conditions, dust, moisture, or other unfavorable conditions exist.</p>

Table 2-1. Preventive Maintenance Checks and Services

D - Daily W - Weekly M - Monthly Q - Quarterly S - Semiannually A - Annually

Item No.	Interval						Items To Be Inspected/ Serviced	Procedures
	D	W	M	Q	S	A		
87							<ul style="list-style-type: none"> <li>● Ship Service/Emergency Switchboard Draw-Out Circuit Breakers - CONT</li> </ul>	<p style="text-align: center;"><u>CONTROL CENTERS/SWITCHBOARDS - CONT</u></p> <p>(4) If the breaker remains open or closed for a long period of time, it is recommended that arrangements be made to open and close it several times in succession, preferably under load.</p> <p>(5) At all times it is important not to permit pencil lines, paint, oil or other foreign materials to remain on the insulating surfaces of the breaker as they may cause low resistance between points of different potential and result in eventual electrical breakdown.</p> <p>(6) Always inspect the circuit breaker after.</p> <p>b. Make the following checks after the circuit breaker has been deenergized.</p> <p>(1) Manually operate the breaker several times checking for obstructions or excessive friction.</p> <p>(2) Electrically operate the breaker several times (if breaker has electrical control) to ascertain whether the electrical attachments are functioning properly.</p>

Table 2-1. Preventive Maintenance Checks and Services

D - Daily W - Weekly M - Monthly Q - Quarterly S - Semiannually A - Annually

Item No.	Interval						Items To Be Inspected/ Serviced	Procedures
	D	W	M	Q	S	A		
87							<ul style="list-style-type: none"> <li>● Ship Service/Emergency Switchboard Draw-Out Circuit Breakers - CONT</li> </ul>	<p style="text-align: center;"><u>CONTROL CENTERS/SWITCHBOARDS - CONT</u></p> <p>(S) Check contact condition and depression.</p> <p>(4) Check latch engagement.</p> <p>(5) Check operation of tripping devices, including overcurrent trip devices, making sure all have positive tripping action (discernible) movement in tripping direction beyond point of tripping),</p> <p>c. Lubrication.</p> <p>(1) Circuit breakers require very little lubrication, Bearing points and sliding surfaces should be lubricated very lightly at the regular inspection periods with a thin film of GE lubrication D50HD38 (Mobile 28). Hardened grease and dirt should be removed from latch and bearing surfaces by the use of safe cleaning solvent such as kerosene. Latch surfaces should be left clean and dry and not be lubricated.</p> <p style="text-align: center;">NOTE</p> <p style="text-align: center;">All excess lubricant should be removed with a clean cloth in order to avoid any accumulation of dirt or dust.</p> <p>d. At each maintenance period, all silver to silver friction points, such as primary disconnects, should be cleaned and given a fresh coat of GE lubricant DSOHD38.</p>



Table 2-1. Preventive Maintenance Checks and Services

D - Daily W - Weekly M - Monthly Q - Quarterly S - Semiannually A - Annually

Item No.	Interval						Items To Be Inspected/ Serviced	Procedures
	D	W	M	Q	S	A		
88							<ul style="list-style-type: none"> <li>● Ship Service/Emergency Switchboard Measuring Instruments.</li> </ul>	<p style="text-align: center;"><u>CONTROL CENTERS/SWITCHBOARDS - CONT</u></p> <p>a. Preliminary.</p> <ol style="list-style-type: none"> <li>(1) Obtain permission from engineering officer to test switchboard instruments.</li> <li>(2) Observe shipboard security regulations.</li> <li>(3) Notify watch standers and equipment operators that electrical switchboard instruments are being tested. Do not energize electrical equipment except for emergencies until further notice.</li> </ol> <p>b. Inspect the switchboard, components, and electrical measuring instruments, as follows:</p> <ol style="list-style-type: none"> <li>(1) Inspect all switchboard electrical indicating instruments for obvious damage such as broken glass or bent pointers.</li> <li>(2) Switchboard power distribution meters, i.e., frequency meter, voltmeters, ammeters and wattmeters, should be cross-checked with those meters installed on alternate or emergency switchboards. Check meters as follows:               <ol style="list-style-type: none"> <li>(a) Note the values indicated on those switchboard instruments being tested. Immediately thereafter, transfer the power load to the alternate ship service or emergency switchboard and note the values indicated on corresponding instruments.</li> </ol> </li> </ol>

Table 2-1. Preventive Maintenance Checks and Services

D - Daily W - Weekly M - Monthly Q - Quarterly S - Semiannually A - Annually

Item No.	Interval						Items To Be Inspected/ Serviced	Procedures
	D	W	M	Q	S	A		
88							<ul style="list-style-type: none"> <li>Ship Service/Emergency Switchboard Measuring Instruments - CONT</li> </ul>	<p align="center"><u>CONTROL CENTERS/SWITCHBOARDS - CONT</u></p> <p>(b) Repeat this process at least three times until it is reasonably certain that there has been no significant load change.</p>
89							<ul style="list-style-type: none"> <li>Motor Control Centers</li> </ul>	<p align="center">NOTE</p> <ul style="list-style-type: none"> <li>Maintenance procedures for all Motor Control Centers are the same.</li> <li>Existing wiring configuration of indicating lamps or electrical interlocks on some controllers may provide a low voltage feedback circuit at auxiliary contacts when equipment power source is deenergized.</li> </ul> <p>Clean and Inspect Controllers.</p> <p>(1) Deenergized circuit(s) to controller and tag "Out of Service - Do Not Operate."</p> <p>(2) Open/remove controller access cover(s).</p>

Table 2-1. Preventive Maintenance Checks and Services

D - Daily W - Weekly M - Monthly Q - Quarterly S - Semiannually A - Annually

Item No.	Interval						Items To Be Inspected/ Serviced	Procedures
	D	W	M	Q	S	A		
89						●	Motor Control Centers - CONT	<p style="text-align: center;"><u>CONTROL CENTERS/SWITCHBOARDS - CONT</u></p> <p style="text-align: center;"><u>WARNING</u></p> <p>Consider all electrical leads to be energized until positively proven they are deenergized.</p> <p>(3) Test unit with a multimeter to ensure circuits are deenergized.</p> <p>(4) Clean interior of controller with rags and dusting brush to clean hard-to-reach areas.</p> <p style="text-align: center;">NOTE</p> <p>Where relay/contactors contacts are not accessible for visual inspection, consult work center supervisor to determine extent of this inspection.</p> <p>(5) Inspect contact surfaces for sharp projections, pitting, misalignment, and overheating.</p>

Table 2-1. Preventive Maintenance Checks and Services

D - Daily W - Weekly M - Monthly Q - Quarterly S - Semiannually A - Annually

Item No.	Interval						Items To Be Inspected/ Serviced	Procedures
	D	W	M	Q	S	A		
89							<ul style="list-style-type: none"> <li>● Motor Control Centers - CONT</li> </ul>	<p style="text-align: center;"><u>CONTROL CENTERS/SWITCHBOARDS - CONT</u></p> <p style="text-align: center;">NOTE</p> <p>The brown discoloration found on silver and silver-plated contacts is harmless. Silver or silver-plated contacts that have sharp projections should be renewed.</p> <p>(6) Inspect shunts/flexible conductors for burned, corroded, broken, and frayed conductors.</p> <p>(7) Inspect wiring for burnt, chafed, frayed, or chipped insulation.</p> <p>(8) Inspect electrical and mechanical connections for tightness.</p> <p>(9) Tighten loose connections; use jamnuts or lockwashers to keep connections tight.</p> <p>(10) Operate each contactor manually several times; moving parts should operate freely without binding or sticking.</p> <p>(11) Close/reinstall controller access cover(s).</p> <p>(12) Remove safety tag(s) and energize circuit(s).</p> <p>(13) Test operate controller when associated equipment can be operated.</p>

Table 2-1. Preventive Maintenance Checks and Services

D - Daily W - Weekly M - Monthly Q - Quarterly S - Semiannually A - Annually

Item No.	Interval						Items To Be Inspected/ Serviced	Procedures
	D	W	M	Q	S	A		
90	•						<p style="text-align: center;"><u>PROPELLER SHAFT ASSEMBLY</u></p> <p>a. Inspect at close range, the full length of all accessible rubber and/or reinforced plastic covering on each shaft for deterioration, physical damage, lack adhesion or other defects. Evidence of loss of adhesion of shaft covering is characterized by one or more of the following:</p> <ol style="list-style-type: none"> <li>(1) Loss of covering, entirely or in part.</li> <li>(2) Rust stains where rust has leaked through the covering in the vicinity of a cut, joint, patch, or other flaw.</li> <li>(3) Water blisters on rubber covering which are recognized by swellings which are soft to the touch.</li> <li>(4) For plastic covering, look for rust stains in the vicinity of a cut, pinhole, area of porosity, patch joint, or other flaw. Tap the plastic covering at regular 18-inch intervals with a light hammer while holding the palm of the hand against the covering on the other side of the shaft. Any vibration, movement of covering or hollow sound is evidence of loose bonding.</li> </ol> <p>b. During operation, observe shafting for any objectionable vibrations.</p>	

Table 2-1. Preventive Maintenance Checks and Services

D - Daily W - Weekly M - Monthly Q - Quarterly S - Semiannually A - Annually

Item No.	Interval						Items To Be Inspected/ Serviced	Procedures
	D	W	M	Q	S	A		
90	•						<p>Propeller Shaft Assembly - CONT</p> <p>c. During operation, check stern tube to see if it is hot to the touch of the hand.</p> <p>d. During operation, check that a thin stream of seawater is trickling by the stuffing box assembly packing gland. If not, this indicates a problem of stern tube seawater cooling.</p>	
91		•					<p>Clean meter faces (plastic) with soapy water. Wipe dry with lintless dry cloth.</p>	
92	•						<p>Electrical Self Generating Tachometer Arbitrary Scale Meters (Wheelhouse and Engine Control Station Consoles)</p> <p><u>VALVES/STRAINERS</u></p> <p>Valves and Strainers</p> <p>Visually inspect for security, corrosion, or evidence of leakage.</p>	

Table 2-1. Preventive Maintenance Checks and Services

D - Daily W - Weekly M - Monthly Q - Quarterly S - Semiannually A - Annually

Item No.	Interval						Items To Be Inspected/ Serviced	Procedures																																				
	D	W	M	Q	S	A																																						
			●				Hot Water Heater	Open drain valve and let water run until clear.																																				
				●			Piping Systems	Check temperature and pressure relief valve (to ensure proper operating condition). Inspect piping systems for cracks, pitting, corrosion, scale, broken or thin pieces in the piping including welded joints, screwed fittings, expansion joints, and watertight bulkhead fittings.																																				
						●	Valves	a. Lubricate bearings and stem threads using a high pressure and temperature lubricant (Dow Corning Molykote G-N paste or equivalent). b. Check torque on bolted bonnet valves and gland bolts.																																				
								<table border="0"> <thead> <tr> <th><u>Valve Site</u></th> <th><u>Bolt Site</u></th> <th><u>Torque in ft-lb</u></th> </tr> </thead> <tbody> <tr> <td>1/4" - 3/8"-1/2"</td> <td>5/16 - 18</td> <td>18 - 20 *</td> </tr> <tr> <td>3/4"</td> <td>3/8 - 16</td> <td>26 - 30 *</td> </tr> <tr> <td>1"</td> <td>1/2 - 13</td> <td>65 - 75</td> </tr> <tr> <td>1-1/4" - 1-1/2"</td> <td>9/16 - 12</td> <td>100 - 115</td> </tr> <tr> <td>2"</td> <td>5/8 - 11</td> <td>140 - 150</td> </tr> <tr> <td colspan="3">Full Port - Gate Valves</td> </tr> <tr> <td>1/4" - 3/8"</td> <td>5/16 - 18</td> <td>18 - 20 *</td> </tr> <tr> <td>1/2"</td> <td>3/8 - 16</td> <td>26 - 30 *</td> </tr> <tr> <td>3/4"</td> <td>1/2 - 13</td> <td>65 - 75</td> </tr> <tr> <td>1" - 1-1/4"</td> <td>9/16 - 12</td> <td>100 - 115</td> </tr> <tr> <td>1-1/2"</td> <td>5/8 - 11</td> <td>140 - 150</td> </tr> </tbody> </table>	<u>Valve Site</u>	<u>Bolt Site</u>	<u>Torque in ft-lb</u>	1/4" - 3/8"-1/2"	5/16 - 18	18 - 20 *	3/4"	3/8 - 16	26 - 30 *	1"	1/2 - 13	65 - 75	1-1/4" - 1-1/2"	9/16 - 12	100 - 115	2"	5/8 - 11	140 - 150	Full Port - Gate Valves			1/4" - 3/8"	5/16 - 18	18 - 20 *	1/2"	3/8 - 16	26 - 30 *	3/4"	1/2 - 13	65 - 75	1" - 1-1/4"	9/16 - 12	100 - 115	1-1/2"	5/8 - 11	140 - 150
<u>Valve Site</u>	<u>Bolt Site</u>	<u>Torque in ft-lb</u>																																										
1/4" - 3/8"-1/2"	5/16 - 18	18 - 20 *																																										
3/4"	3/8 - 16	26 - 30 *																																										
1"	1/2 - 13	65 - 75																																										
1-1/4" - 1-1/2"	9/16 - 12	100 - 115																																										
2"	5/8 - 11	140 - 150																																										
Full Port - Gate Valves																																												
1/4" - 3/8"	5/16 - 18	18 - 20 *																																										
1/2"	3/8 - 16	26 - 30 *																																										
3/4"	1/2 - 13	65 - 75																																										
1" - 1-1/4"	9/16 - 12	100 - 115																																										
1-1/2"	5/8 - 11	140 - 150																																										
								* May be increased 10 ft-lb if necessary.																																				

Table 2-1. Preventive Maintenance Checks and Service

D-Daily      W-Weekly      M-Monthly      Q-Quarterly      S - Semiannually      A-Annually

Item No.	Interval						Items To Be Inspected/ <b>Serviced</b>	Procedures
	D	W	M	Q	S	A		
96				●			Rubber Expansion Joints	<p style="text-align: center;"><u>PIPING SYSTEM - CONT</u></p> Visually inspect for cuts, tears, and cracks that expose reinforcement fabric.
97						●	Hot Water Heater	Clean lime scale for elements using UN ●LIME® delimer. (Item 42, Appendix C).
97A						●	Hot Water Heater Anode	Replace
98		●					Emergency Diesel Generator Day Tank	<p style="text-align: center;">HULL/MISCELLANEOUS</p> a. Inspect day tank fuel return pipe flange, fuel fill pipe flange, fuel supply pipe flange, tank vent pipe flange, and tank drain pipe flange for signs of leakage, If leakage is observed, direct support maintenance is required. b. Inspect liquid quantity indicator for signs of leakage, breaks, or cracks. c. Inspect steel plate hardware for signs of leakage. If leakage is observed, direct support maintenance is required.
99		●					Bowthruster Engine Day Tank	a. Inspect day tank fuel return pipe flange connection, fuel fill pipe flange connection, and fuel drain pipe flange connection for signs of leakage. If leakage is observed, direct support maintenance is required. b. Inspect tank pipe flanges and liquid quantity indicator pipe flanges for signs of leakage. If leakage is observed, direct support maintenance is required. Check supply pipe flange connection for signs of leakage. If leakage is observed, direct support maintenance is required.



Table 2-1. Preventive Maintenance Checks and Services

D - Daily W - Weekly M - Monthly Q - Quarterly S - Semiannually A - Annually

Item No.	Interval						Items To Be Inspected/ Serviced	Procedures
	D	W	M	Q	S	A		
100		•					<p style="text-align: center;"><u>HULL/MISCELLANEOUS - CONT</u></p> <p>a. Inspect day tank fuel return pipe flange connection, fuel fill pipe flange connection, and fuel drain pipe flange connection for signs of leakage. If leakage is observed, direct support maintenance is required.</p> <p>b. Inspect tank pipe flanges and liquid quantity indicator pipe flanges for signs of leakage. If leakage is observed, direct support maintenance is required. supply pipe flange connection for signs of leakage. If leakage is observed, direct support maintenance is required.</p> <p>c. Inspect liquid quantity indicator for signs of leakage, breaks or cracks.</p> <p>d. Inspect day tank vent pipe flange connection and day tank fuel supply pipe flange connection for signs of leakage. If leakage is observed, direct support maintenance is required.</p> <p>e. Inspect day tank hand hole cover plate, hardware, and gasket for signs of leakage. If leakage is observed, direct support maintenance is required.</p> <p>f. Inspect day tank bottom fuel drain pipe flange connection and fuel supply pipe flange connection for signs of leakage. If leakage is observed, direct support maintenance is required.</p>	

Table 2-1. Preventive Maintenance Checks and Services

D - Daily W - Weekly M - Monthly Q - Quarterly S - Semiannually A - Annually

Item No.	Interval						Items To Be Inspected/ Serviced	Procedures
	D	W	M	Q	S	A		
101		●	●				<p style="text-align: center;"><u>HULL/MISCELLANEOUS - CONT</u></p> <p>a. Inspect for unauthorized flammable materials.</p> <p>b. Inspect the following items for damage, deterioration, proper stowage, and parts missing from designated locations, delete items not applicable to ship.</p> <p>(1) Compartment check-off list and watch quarter and station bill, if applicable.</p> <p>(2) Compartment/space label plates, numbering, and division assigned.</p> <p style="text-align: center;">NOTE</p> <p>All piping and ventilation ducts passing through watertight (WT) or airtight (AT) bulkheads must be welded to the bulkhead through which they pass. In fumetight (FT) bulkheads, welded penetrations are not mandatory, but oversize holes are unacceptable.</p> <p>(3) Piping and ventilation duct markings and bulkhead penetrations.</p> <p>(4) Fire station numbering.</p> <p>(5) Valve classification and numbering.</p> <p>(6) Doors, hatches, and scuttle classification and numbering.</p>	

Table 2-1. Preventive Maintenance Checks and Services

D - Daily W - Weekly M - Monthly Q - Quarterly S - Semiannually A - Annually

Item no.	Interval						Items To Be Inspected/ Serviced	Procedures
	D	W	M	Q	S	A		
101		•	•				<p style="text-align: center;"><u>HULL/MISCELLANEOUS - CONT</u></p> <p>(7) Frame numbering.</p> <p>(8) Tanks and voids classification and numbering.</p> <p>(9) Fire hose overboard discharge fitting classification and numbering.</p> <p>(10) Air test fitting caps.</p> <p>(11) Sounding tube fittings, classification and numbering.</p> <p>(12) First aid, decontamination, and traffic markings.</p> <p>(13) T-wrenches (various).</p> <p>(14) Porthole, hatch, and ventilation weather closure open and wrenches.</p> <p>(15) Loose or frayed wiring, lighting fixtures, shields, mounting covers, terminal box covers, receptacle covers with attached chain, and sound-powered telephone covers.</p> <p>(16) Rubber matting or dielectric sheet (rubber or vinyl) associated with electrical equipment.</p>	

Table 2-1. Preventive Maintenance Checks and Services

D - Daily W - Weekly M - Monthly Q - Quarterly S - Semiannually A - Annually

Item No.	Interval						Items To Be Inspected/ Serviced	Procedures
	D	W	M	Q	S	A		
101		•	•				<p><b>HULL/MISCELLANEOUS - CONT</b></p> <p><u>WARNING</u></p> <p>Wear electrical safety gloves while inspecting cables and stuffing tubes.</p> <p>(17) Electrical cable bulkhead penetration stuffing tubes. Push and pull on individual cables and record those that move freely. Probe unused stuffing tubes with welding rod and record all open or soft-sealed (no metal plug) stuffing tubes.</p> <p>(18) Insulation and lagging.</p> <p>(19) Floor plates and gratings.</p> <p>(20) Equipment foundation and supports.</p> <p>(21) Non-watertight doors.</p> <p>(22) Damage control shoring.</p> <p>(23) Posted safety precautions, warning signs, and operating instructions.</p> <p>(24) Posted first aid instructions.</p>	

Table 2-1. Preventive Maintenance Checks and Services

D - Daily W - Weekly M - Monthly Q - Quarterly S - Semiannually A - Annually

Item No.	Interval						Items To Be Inspected/ Serviced	Procedures
	D	W	M	Q	S	A		
101		•	•				<p>Hull Structure, General - CONT</p> <p style="text-align: center;"><u>HULL/MISCELLANEOUS - CONT</u></p> <p>(25) First aid boxes.</p> <p style="text-align: center;"><u>WARNING</u></p> <p>Exercise caution while in darkened compartment.</p> <p>(26) Turn off lights in space and inspect WT/AT/FT bulkheads for holes that admit light into space from normal lighting in adjacent compartment(s).</p> <p style="text-align: center;"><u>WARNING</u></p> <p>To prevent injury to personnel during PMCS, ensure all radiation emitting equipment has been shut down in accordance with TM 55-1905-223-10 and tagged "Out of Service - Do Not Operate."</p> <p>a. Inspect handrails, rungs, bulkhead mounting flat bars, and handrail mounting plates for corrosion, cracks, bends or breaks. If corroded, cracked, bent or broken, depot maintenance is required.</p> <p>b. Inspect flat bar posts and rails for corrosion, cracks, bends or breaks. If corroded, cracked, bent or broken, depot maintenance is required.</p>	
				•			<p>Pilothouse Top Ladders and Handrails</p>	

Table 2-1. Preventive Maintenance Checks and Services

D - Daily W - Weekly M - Monthly Q - Quarterly S - Semiannually A - Annually

Item No.	Interval						Items To Be Inspected/ Serviced	Procedures
	D	W	M	Q	S	A		
102				●			<p>Pilothouse Top Ladders and Handrail - CONT</p> <p>C. Inspect vertical ladder mounting bolts and hex nuts for security. Tighten bolts if loose. Inspect square bar steps and flat bar channels for corrosion, cracks, bends or breaks. If corroded, cracked, bent or broken, depot maintenance is required.</p> <p>d. Inspect storable gangway for corrosion, cracks, bends or breaks in structure. If corroded, cracked, bent or broken, replacement is required.</p> <p>e. Turn on "S" and "X" band radars and HF communication system to operation. Refer to TM 55-1905-223-10.</p> <p>f. Remove "Out of Service - Do not Operate" tags.</p>	
103				●			<p>02 Level Ladders and Handrails</p> <p style="text-align: center;"><u>WARNING</u></p> <p>To prevent injury to personnel, ensure bridge wings are lowered and locked in place. Refer to TM 55-1905-223-10.</p> <p>a. Inspect wire rope and snap hooks for corrosion, cracks, bends or breaks. If corroded, cracked, bent or broken depot maintenance is required.</p>	

Table 2-1. Preventive Maintenance Checks and Services

D - Daily    W - Weekly    M - Monthly    Q - Quarterly    S - Semiannually    A - Annually

Item No.	Interval						Items To Be Inspected/ Serviced	Procedures
	D	W	M	Q	S	A		
103				●			<p>02 Level Ladders and Handrails - CONT</p> <p style="text-align: center;"><u>HULL/MISCELLANEOUS - CONT</u></p> <p>b. Inspect protable stanchion metallic pipe, metallic pipe eyes, pipe footing and quick release pin for corrosion, cracks, bends or breaks. If corroded, cracked, bent or broken, depot maintenance is required.</p> <p>c. Inspect metallic chain and snap hook for corrosion, cracks, bends or breaks. If corroded, cracked, bent or broken, depot maintenance is required.</p> <p>d. Inspect handrail metallic pipe, flat bar pads, metallic pipe, self locking hex nuts and machine bolts for corrosion, cracks, bends or breaks. If corroded, cracked, bend or broken, depot maintenance is required.</p> <p>e. Inspect hinged bridge wings (port and starborad), as follows:</p> <p>(1) Inspect angle bar, turnbuckles, wire rope, thimbles, snap hooks, metallic chain, round bar, metallic pipe, anchor shackles, quick release pins, angle bar, metallic pipe, plate, self-locking hex nuts, machine bolts, metallic pipe and plates for corrosion, cracks, bends or breaks.</p> <p>(2) If any part is corroded, cracked, bent or broken, depot maintenance is required.</p>	

Table 2-1. Preventive Maintenance Checks and Services

D - Daily W - Weekly M - Monthly Q - Quarterly S - Semiannually A - Annually

Item No.	Interval						Items To Be Inspected/ Serviced	Procedures
	D	W	M	Q	S	A		
103				•			02 Level Ladders and Handrails - CONT	<p style="text-align: center;"><u>HULL/MISCELLANEOUS - CONT</u></p> <p>f. Inspect guard rail falt bar and metallic pipe rails for corrosion, cracks, bends or breaks. If corroded, cracked, bent or broken, depot maintenance is required.</p>
104							Forecastle Deck Ladders and Handrails	<p style="text-align: center;"><u>WARNING</u></p> <p>To prevent injury to personnel, ensure bow ramp winch control panels are not operated during PMCS.</p> <p>a. Inspect wire rope and snap hooks for corrosion, cracks, bends or breaks. If corroded, cracked, bent or broken, depot maintenance is required.</p> <p>b. Inspect metallis pipe handrails and supports, diamond plate steps, channels, metallic pipe, flat bar, self-locking hex nuts and machine bolts for corrosion, cracks, bends or breaks. If corroded, cracked, bent or broken, depot maintenance is required.</p> <p>c. Inspect guard rail flat bars and metallic pipe rails for corrosion, cracks, bends or breaks. If corroded, cracked, bent or broken, depot maintenance is required.</p>
105				•			Main Deck Ladders and Handrails	<p>a. Inspect main deck metallic pipe handrails, metallic pipe, flat bar, self-locking hex nuts, machine bolts, diamond plate steps and channels for corrosion, cracks, bends or breaks. If corroded, cracked, bent or broken, depot maintenance is required.</p>



**Table 2-1. Preventive Maintenance Checks and Services**

**D – Daily                  W – Weekly                  M – Monthly                  Q – Quarterly                  S – Semiannually                  A – Annually**

Item No	Interval						Items To Be Inspected/ Serviced	Procedures
	D	W	M	Q	S	A		
								<u>HULL/MISCELLANEOUS – CONT</u>
105				●			Main Deck Ladders and Handrails – cont	b. Inspect metallic bar handrails and supports channels and diamond plate steps for corrosion, cracks, bends or breaks. If corroded, cracked, bent or broken, depot maintenance is required.
106							FM-200 Fire Fighting System	REFERENCE: TM 55-1905-243-24 & P

**Section IV. UNIT TROUBLESHOOTING**

2.11. Symptom Index. Both a symptom index and a troubleshooting table are provided. The symptom index will help you locate the information you need for troubleshooting.

<b>SYMPTOM INDEX</b>		Troubleshooting Procedure (Table 2-2)
<b>BATTERY</b>		
Will not charge		Item 199
Will not hold charge		Item 200
<b>BATTERY CHARGER</b>		
No output		Item 198
<b>BILGE/BALLAST AND FIREMAN PIPING SYSTEM</b>		
Low discharge pressure		Item 217
No discharge pressure		Item 217
<b>BOWTHRUSTER/FIRE PUMP CONTROL SYSTEM</b>		
No air pressure at inlet (supply port #2) when control lever in neutral position.		Item 137
Control station does not respond when control lever in bowthruster control position.		Item 138
RPM's do not increase when control lever in bowthruster control position.		Item 139
Control station does not respond when control lever in fire pump control position.		Item 140
RPM's do not increase when control lever in fire pump control position.		Item 141
<b>BRAKE PANEL ASSEMBLY</b>		
No pressure at port #1		Item 195
No air pressure at port #2		Item 196
No (OUT) air pressure at port #3		Item 197

## SYMPTOM INDEX - CONT

Troubleshooting  
Procedure  
(Table 2-2)CENTRIFUGAL PUMP UNIT (AUXILIARY  
SEAWATER COOLING)

Low discharge pressure	Item 61
Noisy pump/motor operation	Item 63
Pump motor not running	Item 62

## CENTRIFUGAL PUMP UNIT (FRESH WATER)

Low discharge pressure	Item 55
Noisy pump/motor operation	Item 57
Pump motor not running	Item 56

CENTRIFUGAL PUMP UNIT (FRESH WATER)  
BOOSTER) AND (REDUCTION GEAR COOLING  
WATER)

Low discharge pressure	Item 58
Noisy pump/motor operation	Item 60
Pump motor not running	Item 59

## COMPRESSED AIR PIPING SYSTEM

System does not maintain pressure	Item 224
Pressure loss in piping main	Item 225
Low or no pressure at serviced equipment	Item 226
Excessive moisture in system	Item 227

## DIESEL FUEL OIL FILTER/SEPARATOR

High pressure drop indication	Item 14
Motor kicks out	Item 12
Motor won't start	Item 11
No first stage oil discharge	Item 15
No pressure drop indication	Item 13

## DRYER

Heater element cycles on/off	Item 54
Heater element does not heat	Item 52
Heater element shuts of prematurely	Item 53
Motor does not run	Item 51

## ELECTRIC FOOD MIXER

Attachments strike bottom of bowl	Item 32
Attachments strike side of bowl	Item 33
Bowl will not raise	Item 34
Bowl support hard to raise and lower	Item 36
Mixer will not start	Item 29
Motor runs but will not change speed	Item 30

SYMPTOM INDEX - CONT		Troubleshooting Procedure (Table 2-2)
ELECTRIC FOOD MIXER - Cont'd.		
Transmission operates with a skipping motion		Item 35
Unit runs hot or smokes		Item 31
ELECTRIC RANGE		
Heating surface not hot		Item 27
Oven not heating		Item 28
ELECTRICAL RECEPTACLE		
No power output		Item 204
ELECTRICAL SELF GENERATING TACHOMETER (SHAFT)		
Can't dim illumination in one meter		Item 209
No illumination on wheelhouse console scale meters		Item 208
No indications on one tachometer		Item 207
No indications on port shaft tachometer		Item 205
No indications on starboard shaft tachometer		Item 206
ENGINE ROOM CONTROL STATION		
No air pressure at inlet (supply port #2) when control lever in Neutral Standby.		Item 104
Air pressure at ahead (port #1) when control lever in Neutral Standby.		Item 105
Air pressure at astern (port #3) when control lever in Neutral Standby.		Item 106
No air pressure at inlet regulator when control lever in Neutral Standby.		Item 107
Air pressure at out regulator when control lever in Neutral Standby.		Item 108
No air pressure at inlet (supply port #2) when control lever in Ahead Throttle (Initial). Lever at least 20' in the Ahead Position from Center.		Item 109
No air pressure at ahead (port #1) when control lever in Ahead Throttle (Initial). Lever at least 20' in the Ahead Position from Center.		Item 110
Air pressure at astern (port #3) when control lever in Ahead Throttle (Initial). Lever at least 20' in the Ahead Position from Center		Item 111

## SYMPTOM INDEX - CONT

	Troubleshooting Procedure (Table 2-2)
ENGINE ROOM CONTROL STATION (Cont'd)	
No air pressure at inlet regulator when control lever in Ahead Throttle (Initial). Lever at least 20' in the Ahead Position from Center.	Item 112
No air pressure at out regulator when control lever in Ahead Throttle (Initial). Lever at least 20' in the Ahead Position from Center.	Item 113
No air pressure at inlet (supply port #2) when control lever in Ahead Throttle. Lever at least 20" in the Ahead Position from Center.	Item 114
No air pressure at ahead (port #1) when control lever in Ahead Throttle. Lever at least 20' in the Ahead Position from Center.	Item 111
Air pressure at astern (port #3) when control lever in Ahead Throttle. Lever at least 20" in the Ahead Position from Center.	Item 116
No air pressure at inlet regulator when control lever in Ahead Throttle. Lever at least 20" in the Ahead Position from Center.	Item 117
No air pressure at out regulator when control lever in Ahead Throttle lever at least 20' in the Ahead Position from Center.	Item 118
Air pressure at ahead (port #1) when control lever in Neutral-Astern Delay.	Item 119
Air pressure at astern (port #3) when control lever in Neutral-Astern Delay.	Item 120
No air pressure at inlet regulator when control lever in Neutral-Astern Delay.	Item 121
No air pressure at out regulator when control lever in Neutral-Astern Delay.	Item 122
No air pressure at inlet (supply port #2) when control lever in Astern Throttle (Initial). Lever at least 20' in the Astern Position from Center.	Item 123

SYMPTOM INDEX - CONT

Troubleshooting  
Procedure  
(Table 2-2)

	Troubleshooting Procedure (Table 2-2)
ENGINE ROOM CONTROL STATION (Cont'd)	
Air pressure at ahead (port #1) when control lever in Astern Throttle (Initial). Lever at least 20' in the Astern Position from Center.	Item 124
No air pressure at astern (port #3) when control lever in Astern Throttle (Initial). Lever at least 20" in the Astern Position from Center.	Item 125
No air pressure at inlet regulator when control lever in Astern Throttle (Initial). Lever at least 20" in the Astern Position from Center.	Item 126
No air pressure at out regulator when control lever in Astern Throttle (Initial). Lever at least 20" in the Astern Position from Center.	Item 127
No air pressure at inlet (supply port #2) when control lever in Astern Throttle. Lever at least 20' in the Astern Position from Center.	Item 128
Air pressure at head (port #1) when control lever in Astern Throttle. Lever at least 20" in the Astern Position from Center.	Item 129
No air pressure at astern (port #3) when control lever in Astern Throttle. Lever at least 20" in the Astern Position from Center.	Item 130
No air pressure at inlet regulator when control lever in Astern Throttle. Lever at least 20" in the Astern Position from Center.	Item 131
No air pressure at out regulator when control lever in Astern Throttle. Lever at least 20' in the Astern Position from Center.	Item 132
No air pressure at inlet port of station selector valve (four-way directional valve).	Item 133
No air pressure at port #1 when station selector valve is in Pilot House position.	Item 134

## SYMPTOM INDEX - CONT

	Troubleshooting Procedure (Table 2-2)
ENGINE ROOM CONTROL STATION (Cont'd)	
No air pressure at port #2 when station selector valve is in Engine Room Position.	Item 135
Station selector valve still inoperative.	Item 136
FIRE PUMP PIPING SYSTEM	
Low discharge pressure	Item 237
FOAM PROPORTIONERS (AFFF) PIPING SYSTEM	
AFFF system fails to energize when manual control valve is opened	Item 234
AFFF system is energized but only water is discharged	Item 235
No supply of AFFF concentrate	Item 236
FRESH WATER COOLING PIPING SYSTEM	
Low discharge pressure	Item 222
No discharge pressure	Item 223
FUEL OIL TRANSFER PIPING SYSTEM	
Low transfer pump discharge pressure	Item 228
Fuel oil fails to flow into tanks during filling operations	Item 229
Erroneous tank level indications	Item 231
Erratic receiving tank pressure	Item 230
GEAR ACTUATOR	
Control lever in Neutral Standby. Air pressure at Ahead port of gear actuator.	Item 179
Control lever in Neutral Standby. Air pressure at Astern port of gear actuator.	Item 180
Control lever in Ahead Throttle (Initial). No air pressure at Ahead port of gear actuator.	Item 181
Control lever in Ahead Throttle (Initial). Air pressure at Astern port of gear actuator.	Item 182
Control lever in Ahead Throttle (After Delay). No air pressure at Ahead port of gear actuator.	Item 183
Control lever in Ahead Throttle (After Delay). Air pressure at Astern port of gear actuator.	Item 184

## SYMPTOM INDEX - CONT

	Troubleshooting Procedure (Table 2-2)
GEAR ACTUATOR (Cont'd)	
Control lever in Neutral-Astern Delay. Air pressure at Ahead port of gear actuator.	Item 185
Control lever in Neutral-Astern Delay. Air pressure at Astern port of gear actuator.	Item 186
Control lever in Astern Throttle (Initial). Air pressure at Ahead port of gear actuator.	Item 187
Control lever in Astern Throttle (Initial). No air pressure at Astern port of gear actuator.	Item 188
Control lever in Astern Throttle (After Delay). Air pressure at Ahead port of gear actuator.	Item 189
Control lever in Astern Throttle (After Delay). No air pressure at Astern port of gear actuator.	Item 190
GEAR RATE CONTROL SYSTEM	
Control lever in Neutral Standby. Air pressure at ports 1, 2, 3, 4, 5, and 6 of three-way valves. Red pins at bottom of valves down or extended.	Item 142
Control lever in Ahead Throttle (Initial). No air pressure at port #1 of three-way valve. Red pin on valve #1 down or extended.	Item 143
Control lever in Ahead Throttle (Initial). Air pressure at port #2 of three-way valve. Red pin on valve #1 down or extended.	Item 144
Control lever in Ahead Throttle (Initial). Air pressure at port #3 of three-way valve. Red pin on valve #1 down or extended.	Item 145
Control lever in Ahead Throttle (Initial). No air pressure at port #4 of three-way valve. Red pin on valve #2 up or retracted.	Item 146
Control lever in Ahead Throttle (Initial). No air pressure at port #5 of three-way valve. Red pin on valve #2 up or retracted.	Item 147



## SYMPTOM INDEX - CONT

	Troubleshooting Procedure (Table 2-2)
GEAR MATE CONTROL SYSTEM (Cont'd)	
Control lever in Ahead Throttle (Initial). Air pressure at port #6 of three-way valve. Red pin on valve #2 up or retracted.	Item 148
Control lever in Ahead Throttle (After Delay). No air pressure at port #1 of three-way valve. Red pin on valve #1 down or extended.	Item 149
Control lever in Ahead Throttle (After Delay). Air pressure at port #2 of three-way valve. Red pin on valve #1 down or extended,	Item 150
Control lever in Ahead Throttle (After Delay). Air pressure at port #3 of three-way. Red pin on valve #1 down or extended.	Item 151
Control lever in Ahead Throttle (After Delay). No air pressure at port #4 of three-way valve. Red pin on valve #2 up or retracted.	Item 152
Control lever in Ahead Throttle (After Delay). No air pressure at port #5 of three-way valve. Red pin on valve #2 up or retracted.	Item 153
Control lever in Ahead Throttle (After Delay). Air pressure at port #6 of three-way valve. Red pin on valve #2 up or retracted.	Item 154
Control lever in Neutral (Astern Delay Mode). Air pressure at port #1 of three-way valve. Red pin on valve #1 down or extended.	Item 155
Control lever in Neutral (Astern Delay Mode). Air pressure at port #2 on three-way valve. Red pin on valve #1 down or extended.	Item 156
Control lever in Neutral (Astern Delay Mode). Air pressure at port #3 of three-way valve. Red pin on valve #1 down or extended.	Item 157
Control lever in Neutral (Astern Delay Mode). Air pressure at port #4 of three-way valve. Red pin on valve #2 up or retracted.	Item 158

SYMPTOM INDEX - CONT

Troubleshooting  
Procedure  
(Table 2-2)

GEAR MATE CONTROL SYSTEM (Cont'd)	
Control lever in Neutral (Astern Delay Mode). Air pressure at port #5 of three-way valve. Red pin on valve #2 up or retracted.	Item 159
Control lever in Neutral (Astern Delay Mode). Air pressure at port #6 of three-way valve. Red pin on valve #2 up or retracted.	Item 160
Control lever in Astern Throttle (Initial). Air pressure at port #1 of three-way valve. Red pin on valve #1 up or retracted.	Item 161
Control lever in Astern Throttle (Initial). No air pressure at port #2 of three-way valve. Red pin on valve #1 up or retracted.	Item 162
Control lever in Astern Throttle (Initial). No air pressure at port #3 of three-way valve. Red pin on valve #1 up or retracted.	Item 163
Control lever in Astern Throttle (Initial). Air pressure at port #4 of three-way valve. Red pin on valve #2 down or extended.	Item 164
Control lever in Astern Throttle (Initial). Air pressure at port #5 of three-way valve. Red pin on valve #2 down or extended.	Item 165
Control lever in Astern Throttle (Initial). No air pressure at port #6 of three-way valve. Red pin on valve #2 down or extended.	Item 166
Control lever in Astern Throttle (After Delay). Air pressure at port #1 of three-way valve. Red pin on valve #1 up or retracted.	Item 167
Control lever in Astern Throttle (After Delay). No air pressure at port #2 of three-way valve. Red pin on valve #1 up or retracted.	Item 168
Control lever in Astern Throttle (After Delay). No air pressure at port #3 of three-way valve. Red pin on valve #1 up or retracted.	Item 169

## SYMPTOM INDEX - CONT

	Troubleshooting Procedure (Table 2-2)
<b>GEAR MATE CONTROL SYSTEM (Cont'd)</b>	
Control lever in Astern Throttle (After Delay). Air pressure at port #4 of three-way valve. Red pin on valve #2 down or extended.	Item 170
Control lever in Astern Throttle (After Delay). Air pressure at port #5 of three-way valve. Red pin on valve #2 down or extended.	Item 171
Control lever in Astern Throttle (After Delay). No air pressure at port #6 of three-way valve. Red pin on valve #2 down or extended.	Item 172
<b>GOVERNOR ACTUATOR</b>	
Control lever in Neutral-Standby. Governor actuator in extended position.	Item 191
Control lever in Ahead Throttle (Initial). Governor actuator in retracted position.	Item 192
Control lever in Neutral-Astern Delay. Governor actuator in extended position.	Item 193
Control lever in Astern Throttle (Initial). Governor actuator in extended position.	Item 194
<b>GYRO INTERFACE ASSEMBLY</b>	
Gyro interface course reference dial moves in the opposite direction to vessel turn.	Item 67
System does not operate.	Item 68
<b>NOTE</b>	
<b>Lube Oil Purifier removed from vessels with Waste Heat Evaporator upgrade MWO 55-1905-223-55-3.</b>	
<b>MACHINERY PLANT MONITORING AND ALARM SYSTEM</b>	
Message "PROGRAMMING SENSOR, PLEASE WAIT."	Item 74
<b>MOTOR CONTROLLERS</b>	
No power	Item 201

SYMPTOM INDEX - CONT

Troubleshooting  
Procedure  
(Table 2-2)

NAVIGATION LIGHTS

Lights don't work - no power.	Item 20
Lights don't work - power ok.	Item 21
Searchlight lamp flashes internally without starting.	Item 22
Searchlight over-temp light on.	Item 23
Searchlight lamp fails to start with no internal flashing.	Item 24
High frequency output (outage).	Item 25
Auxiliary power (outage).	Item 26

**NOTE**

**OIL-WATER SEPARATOR is not applicable to vessels with OWS upgrade, MWO 55-1905-223-55-6. Reference TM 55-1905-223-24-19 for information for vessels that have the OWS upgrade MWO 55-1905-223-55-6 installed.**

OIL-WATER SEPARATOR

Discharge valve open	Item 7
Inoperative	Item 5
No discharge overboard	Item 6
Oil pump runs continually	Item 8
Pressure differential builds rapidly in second stage	Item 9
Oil level too low in second stage	Item 10

PILOTHOUSE CONTROL STATION

No pressure at inlet (supply port #2) with control lever in neutral standby position	Item 75
Air pressure at ahead (port #1) with control lever in neutral stand-by position	Item 76
Air pressure at astern (port #3) with control lever in neutral stand-by position	Item 77
No air pressure at inlet regulator with control lever in neutral standby position	Item 78
Air pressure at out regulator with control lever in neutral stand-by position	Item 79

## SYMPTOM INDEX - CONT

	Troubleshooting Procedure (Table 2-2)
PILOTHOUSE CONTROL STATION (Cont'd)	
No air pressure at inlet (supply port #2) with control lever in ahead throttle (Initial). Lever at least 20' in the ahead position from center	Item 80
No air pressure at ahead (port #1) with control lever in Ahead Throttle (Initial). Lever at least 20" in the Ahead Position from Center.	Item 81
Air pressure at astern (port #3) with control lever Ahead Throttle (Initial). Lever at least 20' in the Ahead Position from Center.	Item 82
No air pressure at inlet regulator with control lever in Ahead Throttle (Initial).	Item 83
No air pressure at out regulator with control lever in Ahead Throttle (Initial). Lever at least 20' in the Ahead Position from Center.	Item 84
No pressure at inlet (supply port #2) with control lever in Ahead Throttle. Lever at least 20' in the Ahead Position from Center.	Item 85
No air pressure at ahead (port #1) with control lever in Ahead Throttle. Lever at least 20' in the Ahead Position from Center.	Item 86
Air pressure at astern (port #3) with control lever in Ahead Throttle. Lever at least 20' in the Ahead Position from Center.	Item 87
No air pressure at inlet regulator with control lever in Ahead Throttle. Lever at least 20' in the Ahead Position from Center.	Item 88
No air pressure at out regulator with control lever in Ahead Throttle. Lever at least 20' in the Ahead Position from Center.	Item 89
Air pressure at astern (port #1) with control lever in Neutral-Astern Delay.	Item 90

SYMPTOM INDEX - CONT

Troubleshooting  
Procedure  
(Table 2-2)

	Troubleshooting Procedure (Table 2-2)
PILOTHOUSE CONTROL STATION (Cont'd)	
Air pressure at astern (port #3) with control lever in Neutral-Astern Delay.	Item 91
No air pressure at inlet regulator with control lever in Neutral-Astern Delay.	Item 92
Air pressure at out regulator with control lever in Neutral-Astern Delay.	Item 93
No air pressure at inlet (supply port #2) with control lever in Astern Throttle (Initial). Lever at least 20' in the Astern Position from Center.	Item 94
Air pressure at ahead (port #1) with control lever at Astern Throttle (Initial). Lever at least 20' in the Astern Position from Center.	Item 95
No air pressure at astern (port #3) with control lever in Astern Throttle (Initial). Lever at least 20' in the Astern Position from Center.	Item 96
No air pressure at inlet regulator with control lever in Astern Throttle (Initial). Lever at least 20' in the Astern Position from Center.	Item 97
No air pressure at out regulator with control lever in Astern Throttle (Initial). Lever at least 20' in the Astern Position from Center.	Item 98
No air pressure inlet (supply port #2) with control lever in Astern Throttle. Lever at least 20' in the Astern position from Center.	Item 99
Air pressure at ahead (port #1) with control lever in Astern Throttle. Lever at least 20' in the Astern Position from Center.	Item 100
No air pressure at astern (port #3) with control lever in Astern Throttle. Lever at least 20' in the Astern Position from Center.	Item 101

## SYMPTOM INDEX - CONT

Troubleshooting  
Procedure  
(Table 2-2)

## PILOTHOUSE CONTROL STATION (Cont'd)

No air pressure at inlet regulator with control lever in Astern Throttle. Lever at least 20" in the Astern Position from Center. Item 102

No air pressure at out regulator with control lever in Astern Throttle. Lever at least 20' in the Astern Position from Center. Item 103

## POTABLE WATER PIPING SYSTEM

Low discharge pressure Item 213

No discharge pressure Item 214

Excessive pump vibration Item 216

## POWER DISTRIBUTION PANELS

No power Item 202

Fluorescent, incandescent or floodlight does not work Item 203

## REFRIGERATORS AND FREEZERS

High head pressure Item 41

Short cycling Item 40

Unit runs continuously Item 39

Unit does not cool Item 37

Unit does not operate Item 38

ROTARY PUMP UNIT (FUEL OIL TRANSFER),  
(PRELUBE OIL TRANSFER), AND (DIRTY  
LUBE OIL).

Low discharge pressure Item 64

Noisy pump/motor operation Item 66

Pump motor not running Item 65

## RUDDER ANGLE INDICATOR (RAI)

All indicators move in the wrong direction when the rudder is turned Item 69

Dimmer does not work Item 73

One indicator of a multiple station system moves in the wrong direction when the rudder is turned Item 70

The port and starboard hard over pistons are not equal on the indicator(s) Item 71

SYMPTOM INDEX - CONT	
	Troubleshooting Procedure (Table 2-2)
<p>RUDDER ANGLE INDICATOR (RAI) (Cont'd)</p> <p>Too little or too much movement of indicator(s). (Indicator readings are variable +/- one degree)</p>	Item 72
<p>SEWAGE AND PLUMBING PIPING SYSTEM</p> <p>Liquid will not flow through drain</p> <p>Tank cannot be de-watered, eductor suction gauge indicates a vacuum and suction valve is open</p>	Item 232 Item 233
<p>SEAWATER COOLING PIPING SYSTEM</p> <p>Low discharge pressure</p> <p>No discharge pressure</p> <p>Excessive pump vibration</p>	Item 219 Item 220 Item 221
<p>SOLID WASTE COMPACTOR</p> <p>Drawer will not open</p> <p>Unit starts cycle then stops</p> <p>Unit will not operate</p>	Item 44 Item 43 Item 42
<p>SOUND POWERED TELEPHONES</p> <p>Erratic operation</p> <p>No send or receive</p> <p>Won't receive ring</p> <p>Won't send ring</p>	Item 17 Item 16 Item 19 Item 18
<p>THROTTLE INTERLOCK</p> <p>No air pressure at (IN) port of throttle interlock</p> <p>No air pressure at (OUT) port of throttle interlock</p> <p>No oil pressure at (OIL) port of throttle interlock</p> <p>No air pressure at (AIR) port of throttle interlock</p> <p>No air pressure at (VENT) port of throttle interlock</p> <p>No air at throttle</p>	Item 173 Item 174 Item 175 Item 176 Item 177 Item 178
<p>VALVES AND STRAINERS</p> <p>No flow or limited flow through strainer</p> <p>Strainer leaking</p> <p>Valve gasket leaking</p>	Item 211 Item 212 Item 210



## SYMPTOM INDEX - CONT

	Troubleshooting Procedure (Table 2-2)
WASHER MACHINE	
Excessive vibration	Item 49
No agitation	Item 45
No cold water	Item 46
No hot water	Item 47
Timer won't advance	Item 48
Water won't empty	Item 50

**2-12. Troubleshooting.** Table 2-2 lists the common fault conditions that may be found during operation or maintenance of the equipment. Look for causes and do corrective actions in the order listed. This manual cannot list every symptom that may show up, and it cannot list all of the possible causes and corrective actions. If a symptom is not listed, or if it keeps up after you have performed the corrective actions, notify your supervisor.

**Table 2-2. Troubleshooting**

---

<b>Malfunction</b>
<b>Test or Inspection</b>
<b>Corrective Action</b>

---

**Lube Oil Purifier removed from vessels with Waste Heat Evaporator upgrade  
MWO 55-1905-223-55-3.**

Table 2-2. Troubleshooting - CONT

Malfunction	Test or Inspection	Corrective Action
-------------	--------------------	-------------------

## NOTE

Malfunctions 5 through 10 are not applicable to vessels with OWS upgrade, MWO 55-1905-223-55-6. Reference TM 55-1905-223-24-19 for information for vessels that have the OWS upgrade MWO 55-1905-223-55-6 installed.

OIL-WATER SEPARATOR

5. System inoperative when pump switch and power switch turned on.
  - STEP 1. Check for blown fuse or tripped magnetic breaker in motor control box.  
Replace blown fuse or reset breaker (Paragraph 2-26).
  - STEP 2. Check for tripped circuit breaker.  
Reset circuit breaker at miscellaneous machinery power panel.
  - STEP 3. Check for loose or broken wires.  
Repair electrical wiring or tighten loose connections.
  - STEP 4. Check for excessive air in first stage vessel activating air shut down switch.  
Override shut down function of float switch by briefly placing pump switch in MAN position. Switch back to AUTOMATIC when air is evacuated.
  - STEP 5. Check for blown fuse in control module.  
Replace fuse (Paragraph 2-28).
  - STEP 6. Check for low fluid level in holding tank or bilge.  
Position pump selector switch to MAN.
6. Unable to discharge overboard due to closed water discharge valve.
  - STEP 1. Check for loss of electrical power.  
Position pump selector switch and power switch properly.
  - STEP 2. Check for broken wires or splices.  
Repair wiring.
  - STEP 3. Check for oily water.  
Re-circulate water until clean.
7. Solenoid operated water discharge valve stays open.
  - STEP 1. Use multimeter and check proper operation of solenoid.  
Replace solenoid.

Table 2-2. Troubleshooting CONT

Malfunction	Test or Inspection	Corrective Action
-------------	--------------------	-------------------

**OIL-WATER SEPARATOR - CONT.**

- 8. Oil pump operates continually, water pump remains off.
  - STEP 1. Check for suction taken from oil face in holding tank.  
Shut off system, skim excessive oil from holding tank directly to oil storage tank.
- 9. Pressure differential builds rapidly in second pre-filter stage.
  - STEP 1. Check for chemical contamination.  
Remove source of contamination and dilute with clean water.
  - STEP 2. Check for bacterial contamination.  
Avoid stale water, clean bilge tank if necessary. Treat bilge water with BioCide (bacteria killer).
- 10. Oil level too low in second stage separate (below point where probe is installed). Oil discharge valve closes before sufficient oil is discharged or remains closed.
  - STEP 1. Check for blockage in oil discharge line.  
Remove blockage.
  - STEP 2. Check for loose connections, broken wires, etc. in electrical circuit.  
Repair electrical wiring.
  - STEP 3. Check for contamination of oil by chemical or bacteria, rendering oil probe unable to register oil buildup.  
Clean probes teflon sensor. Remove contaminants and contaminated oil.  
Treat bilge water with BioCide (bacteria killer).

**DIESEL FUEL OIL FILTER/SEPARATOR**

- 11. Motor will not start.
  - STEP 1. Check for pump selector switch off.  
Turn on pump selector switch.
  - STEP 2. Check for loose wiring or bad connections.  
Repair wiring or tighten connection.

Table 2-2. Troubleshooting - CONT

## Malfunction

Test or Inspection  
Corrective Action

DIESEL FUEL OIL FILTER/SEPARATOR - CONT

12. Motor runs and thermally kicks out.
- STEP 1. Check for clogged element in second or third stage or closed discharge valve.  
Check that pump discharge pressure is not greater than 50 psi. Reset relief valve as required.
- STEP 2. Check for improper ventilation.  
Increase ventilation to motor.
- STEP 3. Check for improper wiring.  
Provide proper wiring - not less than No. 14 wire size.
13. Very low or no pressure drop indication.
- STEP 1. Check for leak past either coalescer or separator.  
Change elements (para. 2-25, 2-29, 2-30).
14. High pressure drop indication.
- STEP 1. Check for dirty coalescer and/or separator elements.  
Change elements (para. 2-25, 2-29, 2-30).
15. No oil discharge from first stage gravity separator.
- STEP 1. Check for blockage in oil discharge line.  
Remove blockage from line.

SOUND POWERED TELEPHONES

16. Telephone will not receive or transmit.
- STEP 1. Check for defective handset.  
Replace handset (para. 2-31).
17. Low or erratic transmission or reception.
- STEP 1. Check for defective handset.  
Replace handset (para. 2-31).
18. Telephone won't transmit ring to other telephones.
- STEP 1. Check for loose or broken wiring or connections.  
Tighten or replace loose or broken wiring or connections.

Table 2-2. Troubleshooting - CONT

---

Malfunction	Test or Inspection	Corrective Action
-------------	--------------------	-------------------

---

**SOUND POWERED TELEPHONES - CONT**

19. Telephone won't receive ring.

STEP 1. Check for loose or broken wiring.  
Tighten or replace loose or broken wiring.

**NAVIGATION LIGHTS**

20. Light doesn't work, no power.

STEP 1. Check for blown fuse in light panel.  
Replace fuse, (para. 2-40).

STEP 2. Use a multimeter and check for defective switch in light panel.  
Replace switch (para, 2-41).

STEP 3. Check electrical power to light panel.  
Refer to TM 55-1905-223-24-18 (Electrical systems).

21. Light doesn't work, power ok.

STEP 1. Check for defective bulb.  
Replace bulb (para. 2-36).

22. Searchlight lamp flashes internally without starting.

STEP 1. Check voltage in power supply.  
Replace power supply (para. 2-45).

23. Searchlight lamp fails to start with no internal flashing.

STEP 1. Check that door is tightly closed.  
Secure door.

24. Searchlight over-temp light on.

STEP 1. Check if fan is operating.  
Replace fan (para. 2-45).

STEP 2. Check power supply ammeter for proper reading.  
Replace power supply (para. 2-45).

25. High frequency output (outage).

STEP 1. Check panel switch setting. Must be on START or CONTINUOUS.  
Switch to correct setting.

Table 2-2. Troubleshooting - CONT

---

Malfunction	
Test or Inspection	
Corrective Action	

---

**NAVIGATION LIGHTS - CONT**

STEP 2. Spark gaps wrong.  
Check and reset (.008) (PMCS Table 2-1).

26. Auxiliary power (outage).

STEP 1. Check for component overload.  
Reduce load to 10 amperes.

**ELECTRIC RANGE**

27. Heating surface not hot.

STEP 1. Check for tripped circuit breaker.  
Reset circuit breaker at galley power panel.

STEP 2. Make sure all connections are secure.  
Tighten connections.

28. Oven not heating.

STEP 1. Check for tripped circuit breaker.  
Reset circuit breaker at galley power panel.

STEP 2. Make sure all connections are secure.  
Tighten connections.

STEP 3. Check for defective heating element.  
Replace heating element, para. 2-54.

**ELECTRIC FOOD MIXER**

29. Mixer will not start.

STEP 1. Check for tripped circuit breaker.  
Reset circuit breaker at galley power panel.

STEP 2. Push reset button.

STEP 3. Make sure all connections are secure.

30. Motor runs but will not change speeds.

STEP 1. Check for loose speed change lever.  
Remove handle, install key, replace handle and snap lock ring.

Table 2-2. Troubleshooting - CONT

---

Malfunction

Test or Inspection

Corrective Action

---

ELECTRIC FOOD MIXER - CONT

STEP 2. Check if mixer load is too great.  
Stop mixer, shift to another speed and restart mixer.

31. Unit runs hot or smokes.

STEP 1. Check for low oil in gear box.  
Drain out old oil, remove cover plate and add three pints SAE 50 oil (Item 21, Appendix C). Refer to LO 55-1905-223-12.

32. Attachments strike bottom of bowl.

STEP 1. Check if bowl support is out of adjustment.  
Replace bowl support, para. 2-59.

33. Attachments strike sides of bowl.

STEP 1. Check for bent attachments or dented bowl.  
Replace as required, para. 2-59.

34. Bowl will not raise.

STEP 1. Check for defective drag link shaft.  
Repair column and base assembly, para. 2-59.

35. Transmission operates with a skipping motion (fluctuating speed).

STEP 1. Check for overloaded unit.  
Shift to lower speed or reduce quantity of material being mixed.

36. Bowl support hard to raise and lower.

STEP 1. Check for bowl support binding on bowl slides.  
Clean bowl slides and lubricate with light grade oil (Item 20, Appendix C)  
Refer to LO 55-1905-223-12.

**REFRIGERATORS AND FREEZERS**

NOTE

Troubleshooting procedures are common to all refrigerators and freezers. Refer to Index for appropriate repair paragraphs.



Table 2-2. Troubleshooting - CONT

---

Malfunction	Test or Inspection	Corrective Action
-------------	--------------------	-------------------

---

**REFRIGERATORS AND FREEZERS - CONT**

37. Unit does not cool.

STEP 1. Check for tripped circuit breaker.  
Reset circuit breaker on galley power panel.

STEP 2. Check electrical connections.  
Tighten or repair bad connections at galley power panel.

STEP 3. Check that door is tightly closed.  
Adjust strike on door latch.

STEP 4. Check for low refrigerant charge.  
Charge unit, para. 2-69.

STEP 5. Check for dirty evaporator coil.  
Clean/replace coil as required, para. 2-70.

STEP 6. Check for defective condenser.  
Replace condenser, para. 2-69.

STEP 7. Check for defective thermostat.  
Replace evaporator coil assembly, para. 2-70.

38. Unit does not operate.

STEP 1. Check for tripped circuit breaker.  
Reset circuit breaker at galley power panel.

39. Unit runs continuously.

STEP 1. Check that door is tightly closed.  
Adjust strike on door latch.

STEP 2. Check for restricted air flow or dirty condenser.  
Clean condenser.

STEP 3. Check for restricted circulation in storage area.  
Redistribute food items to allow even air flow.

STEP 4. Check for low refrigerant charge.  
Charge unit, para. 2-69.

STEP 5. Check for defective thermostat.  
Replace evaporator coil assembly, para. 2-70.

Table 2-2. Troubleshooting - CONT

---

Malfunction  
Test or Inspection  
Corrective Action

---

**REFRIGERATOR AND FREEZERS - CONT**

40. Short cycling.

STEP 1. Electrical controls are not adjusted correctly.  
Replace condenser unit, para. 2-69.

41. High head pressure.

STEP 1. Check for blocked or dirty condenser.  
Remove blockage and clean condenser,

STEP 2. Check for refrigerant overcharge.  
Bleed off pressure, para. 2-69.

STEP 3. Check for defective compressor.  
Replace condenser unit, para. 2-69.

**SOLID WASTE COMPACTOR**

42. Unit will not operate.

STEP 1. Check for tripped circuit breaker.  
Reset circuit breaker at galley power panel.

STEP 2. Check drawer open.  
Close drawer.

43. Unit starts cycle then stops.

STEP 1. Check for tripped circuit breaker.  
Reset circuit breaker at galley power panel.

STEP 2. Check drawer open.  
Close drawer.

44. Drawer will not open. (Ram is part way down.)

STEP 1. Check for tripped circuit breaker,  
Reset circuit breaker at galley power panel.

STEP 2. Check drawer ajar.  
Close drawer firmly.

STEP 3. Check that key is turned on.  
Turn on key.

Table 2-2. Troubleshooting - CONT

---

Malfunction	Test or Inspection	Corrective Action
-------------	--------------------	-------------------

---

WASHER MACHINE

45. No agitation.

STEP 1. Check for loose or broken wires.  
Tighten or replace wires.

46. No cold water.

STEP 1. Check cold water supply valve.  
Open valve.

47. No hot water.

STEP 1. Check hot water supply valve.  
Open valve.

STEP 2. Clogged pressure hose.  
Clean hose.

STEP 3. Check for loose or broken wires.  
Tighten or replace wires.

48. Timer does not advance.

STEP 1. Timer is designed to pause during filling.  
Allow for completion of fill cycle.

STEP 2. Check water level.  
Timer pauses until water level is correct.

49. Excessive vibration.

STEP 1. Check for unbalanced load in tub.  
Redistribute load.

50. Water won't empty.

STEP 1. Check for crimped drain hose.  
Straighten hose.

STEP 2. Check for obstruction in outer tube outlet hose.  
Clean hose.

Table 2-2. Troubleshooting - CONT

---

Malfunction	Test or Inspection	Corrective Action
-------------	--------------------	-------------------

---

**WASHER MACHINE- CONT**

- STEP 3. Check pump belt.  
Adjust belt, para. 2-83.
- STEP 4. Check for defective pump.  
Replace pump, para. 2-87.

**DRYER**

- 51. Motor does not run.
  - STEP 1. Check for tripped circuit breaker.  
Reset circuit breaker at galley power panel.
  - STEP 2. Check motor push switch for lint.  
Remove lint.
- 52. Heater element does not heat.
  - STEP 1. Check for tripped circuit breaker.  
Reset circuit breaker at galley power panel.
  - STEP 2. Check for defective heater element.  
Replace heater element, para. 2-92.
- 53. Heater element shuts off prematurely.
  - STEP 1. Check exhaust system for proper installation.  
Correct as required.
- 54. Heater element cycle on/off.
  - STEP 1. Check lint filter.  
Clean lint filter.
  - STEP 2. Check for lint in internal dryer ductwork.  
Clean ductwork.
  - STEP 3. Check for lint in external exhaust system.  
Clean exhaust system.

Table 2-2. Troubleshooting - CONT

## Malfunction

Test or Inspection

Corrective Action

**CENTRIFUGAL PUMP UNIT (FRESH WATER)**

## 55. Low discharge pressure.

STEP 1. Check for liquid vortexing (cavitation) in casing.  
Release trapped air from pump casing.

STEP 2. Check for air or gas in liquid.  
Identify source and correct problem.

STEP 3. Check for low liquid level in fresh water tank.  
Shift suction to tank containing water.

STEP 4. Check for partially closed pump suction valve.  
Ensure pump suction valve fully open.

STEP 5. Check for partially closed discharge pressure gauge cutoff valve.  
Ensure discharge pressure gauge cutoff valve fully open.

STEP 6. Check for partially clogged pressure line or defective discharge pressure gauge.  
Clean pressure line. Replace pressure gauge.

STEP 7. Check for partially clogged pump casing and discharge piping.  
Flush pump casing with clean water. Clean trap/strainer in discharge piping (TM 55-1905-223-23-1819).

STEP 8. Check for air leak(s) in suction piping.  
Tighten loose connection(s) in suction piping.

STEP 9. Check hydropneumatic pressure tank for leak(s).  
Tighten loose connection(s). Replace gaskets (TM 55-1905-223-24-1813).

STEP 10. Check pump/motor for wrong direction of rotation.  
Wire motor per instructions given on motor nameplate/decal.

STEP 11. Check for defective pump.  
Replace pump, para. 2-95.

## 56. Pump motor not running.

STEP 1. Check for open pump motor circuit breaker.  
Reset circuit breaker at Main Switchboard 240 V distribution panel on main ship's service switchboard (Engine Control Station).

Table 2-2. Troubleshooting - CONT

---

Malfunction

Test or Inspection

Corrective Action

---

**CENTRAL PUMP UNIT (FRESH WATER) - CONT**

STEP 2. Check start and stop pushbuttons on engine room console panel for online (main) or (standby) pump.  
Reset pushbuttons to start either (main) or (standby) pump.

STEP 3. Check for improper control setpoint on pressure switch.  
Ensure pressure switch turn ON/OFF respective (main) or (standby) pump when tank pressure rises to and drops below the control setpoint.

STEP 4. Check for loose connection(s) or defective electrical wires/cable(s) between engine room console panel and pump motor.  
Tighten loose connection(s). Replace electrical wires/cable(s).  
(TM 55-1905-223-24-1812).

STEP 5. Check for defective motor.  
Replace motor, para. 2-95.

57. Noisy pump/motor operation.

STEP 1. Check for air or gas in liquid.  
Identify source and correct problem.

STEP 2. Check for liquid vortexing (cavitation) in casing.  
Release trapped air from pump casing.

STEP 3. Check for dry bearings.  
Grease pump/motor bearing(s) (Lo 55-1905-223-12).

STEP 4. Check for loose or broken mounting bracket and bolts.  
Tighten loose mounting bracket. Replace bracket/bolts.

STEP 5. Check for damaged pump/motor.  
Replace pump/motor, para. 2-95.

**CENTRIFUGAL PUMP UNIT (FRESH WATER BOOSTER) AND  
(REDUCTION GEAR COOLING WATER)**

58. Low discharge pressure.

STEP 1. Check for liquid vortexing (cavitation) in casing.  
Release trapped air from pump casing.

STEP 2. Check for air or gas in liquid.  
Identify source and correct problem.

Table 2-2. Troubleshooting - CONT

Malfunction

Test or Inspection

Corrective Action

**CENTRIFUGAL PUMP UNIT (FRESH WATER ROOSTER) AND  
(REDUCTION GEAR COOLING WATER) - CONT**

STEP 3. Check for partially closed pump suction valve.  
Ensure pump suction valve fully open.

STEP 4. Check for partially closed discharge pressure gauge cutoff valve.  
Ensure discharge pressure gage cutoff valve fully open.

STEP 5. Check for partially clogged pressure line or defective discharge  
pressure gauge.  
Clean pressure line. Replace pressure gauge.

STEP 6. Check for partially closed hot water heater inlet/outlet valves.  
Ensure hot water heater inlet/outlet valves fully open.

STEP 7. Check for air leak(s) in suction piping.  
Tighten loose connection(s) in suction piping.

STEP 8. Check hydropneumatic pressure tank for leak(s).  
Tighten loose connection(s).

STEP 9. Check for partially clogged pump casing and discharge piping.  
Flush pump casing with clean water. Clean trap/strainer in discharge  
piping (TM 55-1905-223-24-1819).

STEP 10. Check pump/motor for wrong direction of rotation.  
Wire motor per instructions given on motor nameplate/decal.

STEP 11. Check for defective pump.  
Replace pump, para. 2-97.

59. Pump motor not running.

STEP 1. Check for open pump motor circuit breaker.  
Reset circuit breaker for (reduction gear cooling water) pumps No. 1 and  
No. 2 at AUX MCHRY MCC.

STEP 2. Check start and stop pushbuttons on motor controllers adjacent to each  
pump motor.  
Reset pushbutton to start pump(s) as required.

STEP 3. Check for loose connection(s)/defective electrical wires/cable(s)  
between AUX MCHRY MCC.  
Tighten loose connection(s). Replace electrical wires/cable(s).  
(TM 55-1905-223-24-1812).

Table 2-2. Troubleshooting - CONT

---

Malfunction

Test or Inspection

Corrective Action

---

**CENTRIFUGAL PUMP UNIT (FRESH WATER BOOSTER) AND  
(REDUCTION GEAR COOLING WATER) - CONT**

STEP 4. Check for defective motor.  
Replace motor, para. 2-97.

60. Noisy pump/motor operation.

STEP 1. Check for air or gas in liquid.  
Identify source and correct problem.

STEP 2. Check for liquid vortexing (cavitation) in casing.  
Release trapped air from pump casing.

STEP 3. Check for dry bearings.  
Grease pump/motor bearing(s) (Lo 55-1905-223-12).

STEP 4. Check for loose or broken mounting bracket and bolts.  
Tighten loose mounting bracket. Replace bracket/bolts.

STEP 5. Check for damaged pump/motor.  
Replace pump/motor, para. 2-97.

**CENTRIFUGAL PUMP UNIT (AUXILIARY SEAWATER COOLING) - CONT**

61. Low discharge pressure.

STEP 1. Check for liquid vortexing (cavitation) in casing.  
Release trapped air from pump casing.

STEP 2. Check for air or gas in liquid.  
Identify source and correct problem.

STEP 3. Check for marine growth or other foreign matter buildup on sea chest inlet.  
Back flush sea chest using ship's compressed air system.

STEP 4. Check for partially closed seawater supply valve.  
Ensure seawater supply valve fully open.

STEP 5. Check for dirty or restricted duplex strainer.  
Clean duplex strainer (TM 55-1905-223-24-1818).

STEP 6. Check for partially closed pump suction valve.  
Ensure pump suction valve fully open.



Table 2-2. Troubleshooting - CONT

---

Malfunction

Test or Inspection

Corrective Action

---

**CENTRIFUGAL PUMP UNIT (AUXILIARY SEAWATER COOLING)- UNIT**

- STEP 7. Check for partially closed discharge pressure gauge cutoff valve.  
Ensure discharge pressure gauge cutoff valve fully open.
- STEP 8. Check for partially clogged pressure line or defective pressure gauge.  
Clean pressure line. Replace pressure gauge.
- STEP 9. Check for partially clogged pump casing.  
Remove drain plug/flush pump casing/replace drain plug.
- STEP 10. Check for air leak(s) in suction piping.  
Tighten loose connection(s) in suction piping.
- STEP 11. Check pump/motor for wrong direction of rotation.  
Wire motor per instructions given on motor nameplate/decal.
- STEP 12. Check for defective pump.  
Replace pump, para. 2-99.
62. Pump motor not running.
- STEP 1. Check for open pump motor circuit breaker.  
Reset circuit breaker for AUX MCHRY MCC.
- STEP 2. Check for loose connection(s) or defective electrical wires/cable(s)  
between AUX MCHRY MCC and pump motor.  
Tighten loose connection(s). Replace electrical wires/cable(s).  
(TM 55-1905-223-24-1812).
- STEP 3. Check for defective motor.  
Replace motor, para. 2-99.
63. Noisy pump/motor operation.
- STEP 1. Check for air or gas in liquid.  
Identify source and correct problem.
- STEP 2. Check for liquid vortexing (cavitation) in casing.  
Release trapped air from pump casing.
- STEP 3. Check for dry bearings.  
Grease pump/motor bearing(s) (Lo 55-1905-223-12).
- STEP 4. Check for loose or broken mounting bracket and bolts.  
Tighten loose mounting bracket. Replace bracket/bolts.

Table 2-2. Troubleshooting - CONT

---

Malfunction
Test or Inspection
Corrective Action

---

**CENTRIFUGAL PUMP UNIT (AUXILIARY SEAWATER COOLING) - CONT**

STEP 5. Check for damaged pump/motor.  
Replace pump/motor, para. 2-99.

**ROTARY PUMP UNIT (FUEL OIL TRANSFER)  
(PRELUBRICATING OIL TRANSFER)  
AND (DIRTY LUBRICATING OIL)**

64. Low discharge pressure.

STEP 1. Check for liquid vortexing (cavitation) in casing.  
Release trapped air from pump casing.

STEP 2. Check for air or gas in liquid.  
Identify source and correct problem.

STEP 3. Check for partially closed pump suction valve.  
Ensure pump suction valve fully open.

STEP 4. Check for partially closed discharge pressure gauge cutoff valve.  
Ensure discharge pressure gauge cutoff valve fully open.

STEP 5. Check for partially clogged pressure line or defective pressure gauge.  
Clean pressure line. Replace pressure gauge.

STEP 6. Check for air leak(s) in suction piping.  
Tighten loose connection(s) in suction piping.

STEP 7. Check pump/motor for wrong direction of rotation.  
Wire motor per instructions given on motor nameplate/decal.

STEP 8. Check for defective pump.  
Replace pump, para. 2-101.

65. Pump motor not running.

STEP 1. Check for open pump motor circuit breaker.

- a. Reset circuit breaker for No. 1 fuel oil transfer pump at AUX MCHRY MCC and START/STOP pushbutton and an emergency STOP switch at the pump.
- b. Reset circuit breaker for No. 2 fuel oil transfer pump at emergency switchboard 240 V distribution and START/STOP pushbutton controller and an emergency stop pushbutton.
- c. Reset circuit breaker for (prelubricating oil transfer) pump at AUX MCHRY MCC and START/STOP pushbutton controller adjacent to pump.

Table 2-2. Troubleshooting CONT

Malfunction	Test or Inspection	Corrective Action
-------------	--------------------	-------------------

**ROTARY PUMP UNIT (FUEL OIL TRANSFER)  
(PRELUBRICATING OIL TRANSFER)  
AND (DIRTY LUBRICATING OIL) - CONT**

- d. Reset circuit breaker for (dirty lubricating oil) pump at AUX MCHRY MCC and START/STOP pushbutton controller adjacent to pump.

**NOTE**

**Halon is not applicable to vessels with FM-200 Fire Suppressant System installed. Reference TM 55-1905-243-24&P, LCU-2000, FM-200 Fire Fighting System for maintenance and installation of FM-200 components.**

STEP 2. Fuel oil transfer pumps No. 1 and No. 2 shut down during activation of halon system. This is a normal shut down. Wait for all clear sign before proceeding with checks.

STEP 3. Check for loose connection(s) or defective electrical wires/cable(s) between AUX MCHRY MCC/emergency switchboard 240 V distribution, START/STOP pushbuttons, emergency stop pushbuttons for transfer and dirty oil pumps.

Tighten loose connection(s). Replace electrical wires/cable(s). (TM 55-1905-223-24-18-1 & 2).

66. Noisy pump/motor operation.

STEP 1. Check for air or gas in liquid.  
Identify source and correct problem.

STEP 2. Check for liquid vortexing (cavitation) in casing.  
Release trapped air from pump casing.

STEP 3. Check for dry bearings.  
Grease pump/motor bearing(s) (LO 55-1905-223-12).

STEP 4. Check for loose or broken mounting bracket and bolts.  
Tighten loose mounting bracket. Replace bracket/bolts.

STEP 5. Check for damaged pump/motor.  
Replace pump/motor, Paragraph 2-101.

**GYRO INTERFACE ASSEMBLY**

67. Gyro interface course reference dial moves in the opposite direction to vessel turn.

STEP 1. Check to see if the wiring is reversed. See gyro interface wiring diagram schematic.

- a. Synchro type inputs - reverse connections S1 and S2 on the terminal strip labeled Gyro Transmission Unit in the gyro interface unit.

Table 2-2. Troubleshooting CONT

---

Malfunction	Test or Inspection	Corrective Action
-------------	--------------------	-------------------

---

GYRO INTERFACE ASSEMBLY - CONT

- b. Stopping motor type inputs - reverse connections 1 and 2 on the terminal strip labeled Gyro Transmission Unit in the gyro interface unit.

68. System does not operate.

STEP 1. Check for incorrect or disconnected wiring.  
Recheck wiring diagram for proper connections.

STEP 2. Check for mechanical binding of gears in gyro interface.  
Disconnect stepper or synchro input to gyro interface. Rotate brass knurled knob so that course dial rotates freely through 360° rotation.  
Adjust backlash if necessary.

STEP 3. Check to see if the gyro transmission unit output switch is in the correct position.  
Turn gyro transmission switch to ON position.

Gyro Interface Wiring Diagram Schematic.

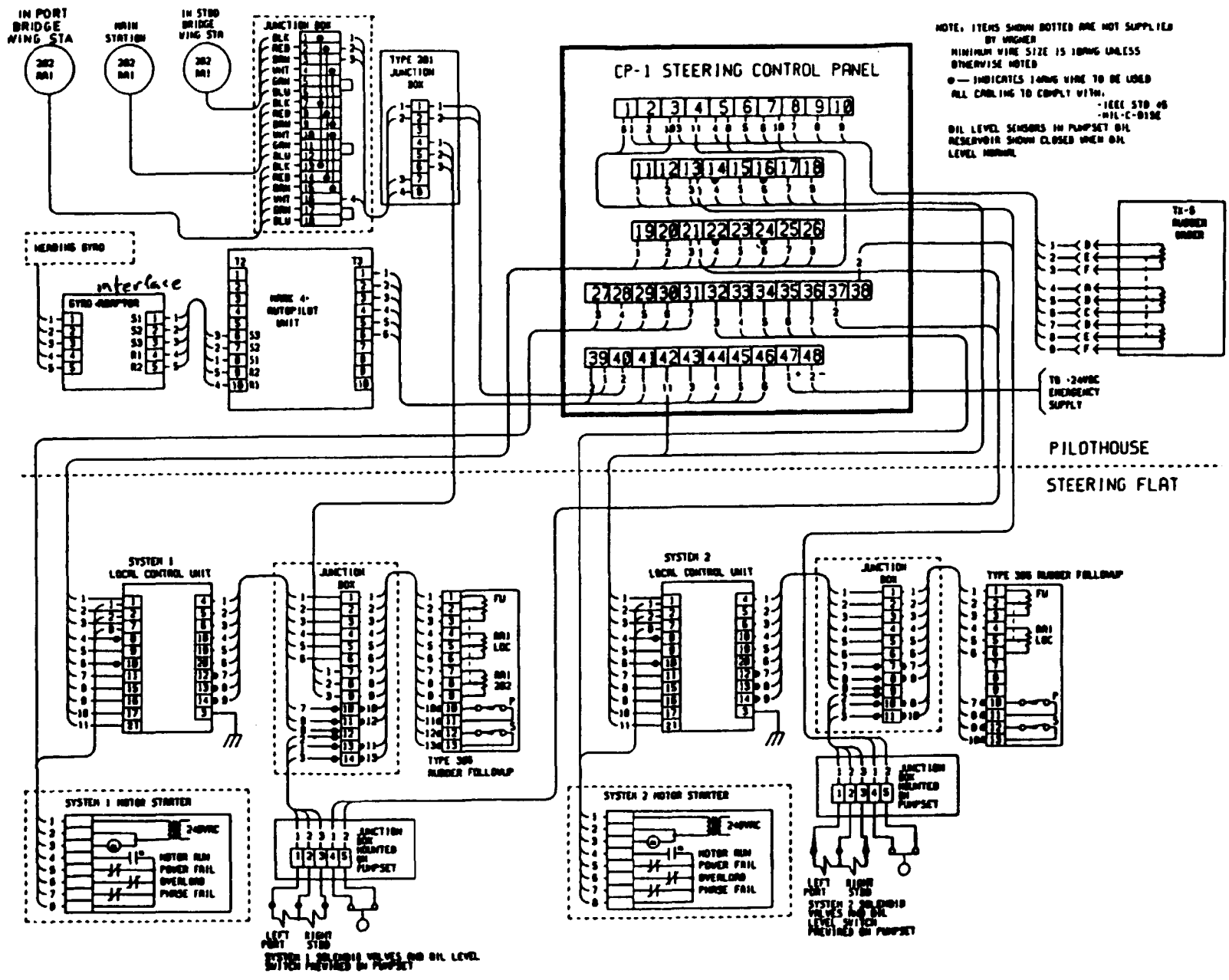


Table 2-2. Troubleshooting

Table 2-2. Troubleshooting - CONT

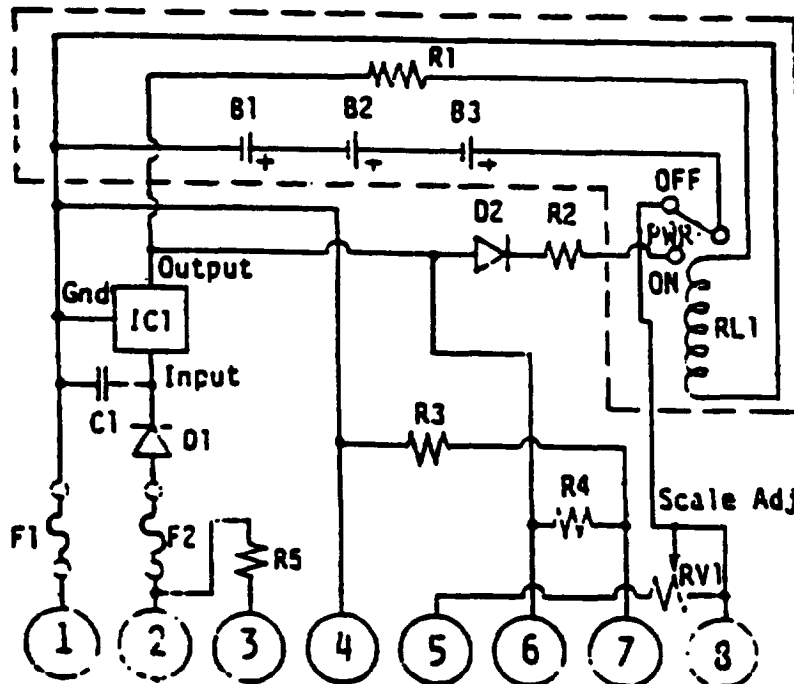
Malfunction	Test or Inspection	Corrective Action
-------------	--------------------	-------------------

**RUDDER ANGLE INDICATOR (RAI)**

69. All indicators move in the wrong direction when the rudder is turned.

STEP 1. Inspect wiring in junction box for correct connections.

Reverse connections at terminals 4 and 6 in junction box, see junction box wiring diagram.



**Junction Box Wiring Diagram**

70. One indicator of a multiple station system moves in the wrong direction when the rudder is turned.

STEP 1. Inspect wiring in indicator that moves in wrong direction of proper connections.

Reverse brown and white wires on faulty indicator. See rudder angle indicator wiring diagram.

Rudder Angle Indicator Wiring.

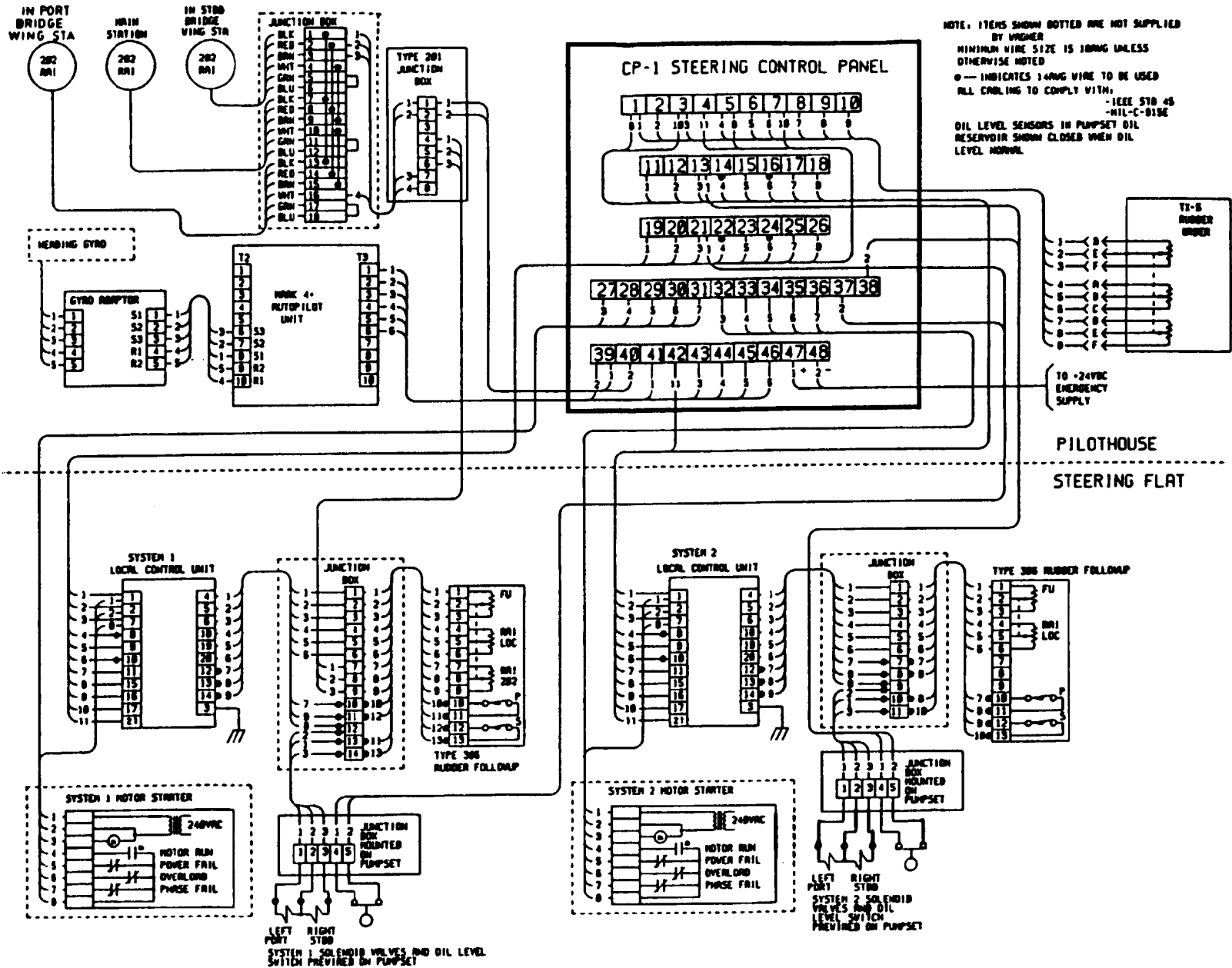


Table 2-2. Troubleshooting

Malfunction  
 Test or Inspection  
 Corrective Action

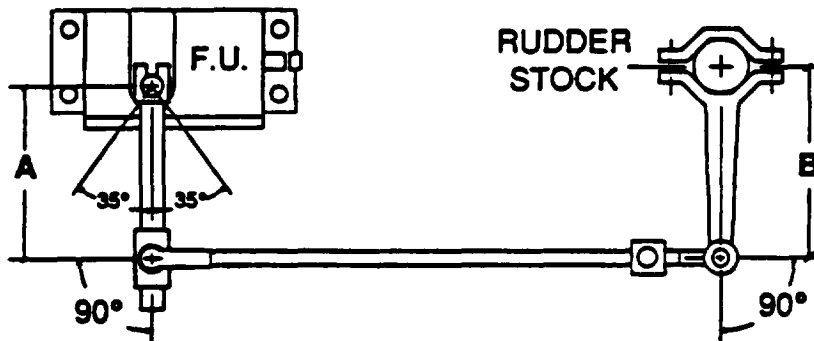
**RUDDER ANGLE INDICATOR (RAI) - CONT**

71. The port and starboard hard over pistons are not equal on the indicator(s).

STEP 1. Check to see if the follow-up linkage is hooked up according to instructions. See follow-up and linkage installation diagram.

**WARNING**

It is extremely important that all mechanical connections to the follow-up unit, including hold down bolts, linkage, and rudder stock, are tightened securely and prevented from loosening through vibration. Use positive locking devices on all connections. A loose mechanical connection can cause loss of steering control.



**OVERHEAD VIEW A=B**

Follow-Up and Linkage Installation Diagram.

72. Too little or too much movement of indicator(s). (Indicator readings are variable +/- one degree.

STEP 1. Check to see if the trimming potentiometer inside the junction box is adjusted correctly.  
 Adjust trimming potentiometer until you get a 0' deflection of the needle on the rudder indicator(s).

73. Dimmer does not work.

STEP 1. Check to see if the 1/2 amp fuse on the indicator circuit board is blown.

Replace fuse, para. 2-114.

STEP 2. Check for burned out lamp.

Replace lamp, para. 2-114.



Table 2-2. Troubleshooting - CONT

---

Malfunction  
 Test or Inspection  
 Corrective Action

---

**MACHINERY PLANT MONITORING AND ALARM SYSTEM**

**74. Message** "PROGRAMMING SENSOR, PLEASE WAIT."

STEP 1. Check for blown fuse, F1 on analog remote module board.  
 Replace fuse, para. 2-137.

**PILOTHOUSE CONTROL STATION**

**NOTE**

Refer to Figure 2-1 and Table 2-3 for normal indications.

**75. No pressure at inlet (supply port #2) with control lever in Neutral Stand-By position.**

STEP 1. Check venturi meter for correct reading (120 psi).  
 Replace venturi meter, para. 2-116.

STEP 2. Check to see if compressor is on.  
 Turn air compressor on, TM 55-1905-223-10.

STEP 3. Check to see if inlet and outlet levers on air prep system are in the on position.  
 Turn levers to on position, para. 2-121.

STEP 4. Check for defective inlet ball valves in air prep system.  
 Replace inlet ball valves, para. 2-121.

STEP 5. Check for defective safety valves in air prep system.  
 Replace safety valves, para. 2-121.

STEP 6. Check for defective venturi meter in air prep system.  
 Replace venturi meter, para. 2-121.

STEP 7. Check for defective outlet ball valves in air prep system.  
 Replace outlet ball valves, para. 2-121.

STEP 8. Defective station selector valve (four-way directional valve).  
 Replace four-way directional valve, para. 2-118.

STEP 9. Check for defective linear directional control valve (station transfer valve).  
 Replace linear directional control valve, para. 2-125.

Table 2-2. Troubleshooting - CONT

---

Malfunction	Test or Inspection	Corrective Action
-------------	--------------------	-------------------

---

**PILOTHOUSE CONTROL STATION - CONT**

76. Air pressure at ahead (port #1) with control lever in Neutral Stand-By position.  
STEP 1. Check for defective directional control rotary valve.  
Repair/replace directional control rotary valve, para. 2-117.
77. Air pressure at astern (port #3) with control lever in Neutral Stand-By position.  
STEP 1. Check for defective directional control rotary valve.  
Repair/Replace directional control rotary valve, para. 2-117.
78. No air pressure at inlet regulator with control lever in Neutral Stand-By position.  
STEP 1. Refer to Malfunction 75, STEPS 1 thru 8.
79. Air pressure at out regulator with control lever in Neutral Stand-By position.  
STEP 1. Check for defective directional control rotary valve.  
Repair/Replace direction control rotary valve, para. 2-117.
80. No air pressure at inlet (supply port #2) with control lever in Ahead Throttle (Initial). Lever at least 20° in the Ahead Position from center.  
STEP 1. Refer to Malfunction 75, STEPS 1 thru 8.
81. No air pressure at ahead (port #1) with control lever in Ahead Throttle (Initial). Lever at least 20° in the Ahead Position from Center.  
STEP 1. Check for defective directional control rotary valve  
Repair/replace directional control rotary valve, para. 2-117.
82. Air pressure at astern (port #3) with control lever in Ahead Throttle (Initial). Lever at least 20° in the Ahead Position from Center.  
STEP 1. Check for defective directional control rotary valve.  
Repair/Replace directional control rotary valve, para. 2-117.
83. No air pressure at inlet regulator with control lever in Ahead Throttle (Initial).  
STEP 1. Refer to Malfunction 75, STEPS 1 thru 8.

---

Malfunction  
Test or Inspection  
Corrective Action

---

**PILOTHOUSE CONTROL STATION - CONT**

84. No air pressure at out regulator with control lever in Ahead Throttle (Initial). Lever at least 20° in the Ahead Position from Center.
- STEP 1. Refer to Malfunction 75, STEPS 1 thru 8 and Malfunction 79, STEP 1.
85. No air pressure at inlet (supply port #2) with control lever in Ahead Throttle. Lever at least 20° in the Ahead Position from Center.
- STEP 1. Refer to Malfunction 75, STEPS 1 thru 8.
86. No air pressure at ahead (port #1) with control lever in Ahead Throttle. Lever at least 20° in the Ahead Position from Center.
- STEP 1. Check for defective directional control rotary valve.  
Repair/Replace direction control rotary valve, para. 2-117.
87. Air pressure at astern (port #3) with control lever in Ahead Throttle. Lever at least 20° in the Ahead Position from Center.
- STEP 1. Check for defective directional control rotary valve.  
Replace/Repair directional control rotary valve, para. 2-117.
88. No air pressure at inlet regulator with control lever in Ahead Throttle. Lever at least 20° in the Ahead Position from Center.
- STEP 1. Refer to Malfunction 75, STEPS 1 thru 8.
89. No air pressure at out regulator with control lever in Ahead Throttle. Lever at least 20° in the Ahead Position from Center.
- STEP 1. Refer to Malfunction 75, STEPS 1 thru 8 and Malfunction 78, STEP 1.
90. Air pressure at ahead (port #1) with control lever in Neutral-Astern Delay.
- STEP 1. Check for defective directional control rotary valve.  
Repair/replace directional control rotary valve, para. 2-117.
91. Air pressure at astern (port #3) with control lever in Neutral-Astern Delay.
- STEP 1. Check for defective directional control rotary valve.  
Repair/Replace directional control rotary valve, para. 2-117.
92. No air pressure at inlet regulator with control lever in Neutral-Astern Delay.
- STEP 1. Refer to Malfunction 75 STEPS 1 thru 8.

---

Malfunction  
Test or Inspection  
Corrective Action

---

PILOTHOUSE CONTROL STATION - CONT

93. Air pressure at out regulator with control lever in Neutral-Astern Delay.
- STEP 1. Check for defective directional control rotary valve.  
Repair/Replace direction control rotary valve, para. 2-117.
94. No air pressure at inlet supply port #2) with control lever in Astern Throttle (Initial). Lever at least 20° in the Astern Position from Center.
- STEP 1. Refer to Malfunction 75, STEPS 1 thru 8.
95. Air pressure at ahead (port #1) with control lever in Astern Throttle (Initial). lever at least 20° in the Astern Position from Center.
- STEP 1. Check for defective directional control rotary valve.  
Repair/replace directional control rotary valve, para. 2-117.
96. No air pressure at astern (port #3) with control lever in Astern Throttle (Initial). Lever at least 20° in the Astern Position from Center.
- STEP 1. Check for defective directional control rotary valve.  
Repair/Replace directional control rotary valve, para. 2-117.
97. No air pressure at inlet regulator with control lever in Astern Throttle (Initial). Lever at least 20° in the Astern Position from Center.
- STEP 1. Refer to Malfunction 75, STEPS 1 thru 8.
98. No air pressure at out regulator with control lever in Astern Throttle (Initial). Lever at least 20° in the Astern Position from Center.
- STEP 1. Refer to Malfunction 75, STEPS 1 thru 8 and Malfunction 78, STEP 1.
99. No air pressure inlet (supply port #2) with control lever in Astern Throttle. lever at least 20° in the Astern position from Center.
- STEP 1. Refer to Malfunction 75, STEPS 1 thru 8.
100. Air pressure at ahead (port #1) with control lever in Astern Throttle. Lever at least 20° in the Astern Position from Center.
- STEP 1. Check for defective directional control rotary valve.  
Repair/replace directional control rotary valve, para. 2-117.

Table 2-2. Troubleshooting - CONT

---

Malfunction	Test or Inspection	Corrective Action
-------------	--------------------	-------------------

---

**PILOTHOUSE CONTROL STATION - CONT**

101. No air pressure at astern (port #3) with control lever in Astern Throttle. Lever at least 20° in the Astern Position from Center.

STEP 1. Check for defective directional control rotary valve.  
Repair/Replace direction control rotary valve, para. 2-117.

102. No air pressure at inlet regulator with control lever in Astern Throttle. Lever at least 20° in the Astern Position from Center.

STEP 1. Refer to Malfunction 75, STEPS 1 thru 8.

103. No air pressure at out regulator with control lever in Astern Throttle. Lever at least 20° in the Astern Position from Center.

STEP 1. Refer to Malfunction 75, STEPS 1 thru 8 and Malfunction 79, STEP 1.

**ENGINE ROOM CONTROL STATION**

**NOTE**

Refer to Figure 2-1 and Table 2-3 for normal indications.

104. No air pressure at inlet (supply port #2) when control lever in Neutral Stand-By.

STEP 1. Check for defective venturi meter.  
Replace venturi meter, para. 2-117.

STEP 2. Refer to Malfunction 75, STEPS 2 thru 8.

105. Air pressure at ahead (port #1) when control lever in Neutral Stand-By.

STEP 1. Repair/replace engine room control station, para. 2-118.

106. Air pressure at astern (port #3) when control lever in Neutral Stand-By.

STEP 1. Refer to Malfunction 103, STEP 1 and Malfunction 104, STEP 1.

107. No air pressure at inlet regulator when control lever in Neutral Stand-By.

STEP 1. Refer to Malfunction 104, STEPS 1 and 2.

Table 2-2. Troubleshooting - CONT

---

Malfunction	
Test or Inspection	
Corrective Action	

---

**ENGINE ROOM CONTROL STATION - CONT**

108. Air pressure at out regulator when control lever in Neutral Stand-By.  
 STEP 1. Repair/replace engine room control station, pare. 2-118.
109. No air pressure at inlet (supply port #2) when control lever in Ahead Throttle (Initial). Lever at least 20° in the Ahead Position from Center.  
 STEP 1. Refer to Malfunction 104, STEPS 1 and 2.
110. No air pressure at ahead (port #1) when control lever in Ahead Throttle (Initial). Lever at least 20° in the Ahead Position from Center.  
 STEP 1. Refer to Malfunction 104, STEPS 1 and 2 and Malfunction 105, STEP 1.
111. Air pressure at astern (port #3) when control lever in Ahead Throttle (Initial). Lever at least 20° in the Ahead Position from Center.  
 STEP 1. Refer to Malfunction 104, STEPS 1 and 2 and Malfunction 105, STEP 1.
112. No air pressure at inlet regulator when control lever in Ahead Throttle (Initial). Lever at least 20° in the Ahead Position from Center.  
 STEP 1. Refer to Malfunction 104, STEPS 1 and 2.
113. No air pressure at out regulator when control lever in Ahead Throttle (Initial). Lever at least 20° in the Ahead Position from Center.  
 STEP 1. Refer to Malfunction 104, STEPS 1 and 2 and Malfunction 105, STEP 1.
114. No air pressure at inlet (supply port #2) when control lever in Ahead Throttle. Lever at least 20° in the Ahead Position from Center.  
 STEP 1. Refer to Malfunction 104, STEPS 1 and 2.
115. No air pressure at ahead (port #1) when control lever in Ahead Throttle. Lever at least 20° in the Ahead Position from Center.  
 STEP 1. Refer to Malfunction 104, STEPS 1 and 2 and Malfunction 105, STEP 1.
116. Air pressure at astern (port #3) when control lever in Ahead Throttle. Lever at least 20° in the Ahead Position from Center.  
 STEP 1. Refer to Malfunction 105, STEP 1 and Malfunction 104, STEPS 1 and 2.

Table 2-2. Troubleshooting - CONT

Malfunction	Test or Inspection	Corrective Action
<b><u>ENGINE ROOM CONTROL STATION - CONT</u></b>		
117. No air pressure at inlet regulator when control lever in Ahead Throttle. Lever at least 20° in the Ahead Position from Center.		STEP 1. Refer to Malfunction 104, STEPS 1 and 2.
118. No air pressure at out regulator when control lever in Ahead Throttle. Lever at least 20° in the Ahead Position from Center.		STEP 1. Refer to Malfunction 104, STEPS 1 and 2 and Malfunction 105. STEP 1.
119. Air pressure at ahead (port #1) when control lever in Neutral-Astern Delay.		STEP 1. Refer to Malfunction 104, STEPS 1 and 2 and Malfunction 105, STEP 1.
120. Air pressure at astern (port #3) when control lever in Neutral-Astern Delay.		STEP 1. Repair/replace engine room control station, para. 2-118.
121. No air pressure at inlet regulator when control lever in Neutral-Astern Delay.		STEP 1. Refer to Malfunction 75 STEPS 1 through 8.
122. No air pressure at out regulator when control lever in Neutral-Astern Delay.		STEP 1. Refer to Malfunction 105, STEP 1 and Malfunction 104, STEPS 1 and 2.
123. No air pressure at inlet (supply port #2) when control lever in Astern Throttle (Initial). Lever at least 20° in the Astern Position from Center.		STEP 1. Refer to Malfunction 104, STEPS 1 and 2.
124. Air pressure at ahead (port #1) when control lever in Astern Throttle (Initial). Lever at least 20° in the Astern Position from Center.		STEP 1. Repair/replace engine room control station, para. 2-118.
125. No air pressure at astern (port #3) when control lever in Astern Throttle (Initial). Lever at least 20° in the Astern Position from Center.		STEP 1. Repair/replace engine room control station, para. 2-118.

Table 2-2. Troubleshooting - CONT

---

Malfunction

Test or Inspection

Corrective Action

---

**ENGINE ROOM CONTROL STATION - CONT**

126. No air pressure at inlet regulator when control lever in Astern Throttle (Initial). Lever at least 20° in the Astern Position from Center.

STEP 1. Repair/replace engine room control station, para. 2-118.

127. No air pressure at out regulator when control lever in Astern Throttle (Initial). Lever at least 20° in the Astern Position from Center.

STEP 1. Refer to Malfunction 105, STEP 1 and Malfunction 104, STEPS 1 and 2.

128. No air pressure at inlet (supply port #2) when control lever in Astern Throttle. Lever at least 20° in the Astern Position from Center.

STEP 1. Refer to Malfunction 104, STEPS 1 and 2.

129. Air pressure at ahead (port #1) when control lever in Astern Throttle. Lever at least 20° in the Astern Position from Center.

STEP 1. Repair/replace engine room control station, para. 2-118.

130. No air pressure at astern (port #3) when control lever in Astern Throttle. Lever at least 20° in the Astern Position from Center.

STEP 1. Repair/replace engine room control station, para. 2-118.

131. No air pressure at inlet regulator when control lever in Astern Throttle. Lever at least 20° in the Astern Position from Center.

STEP 1. Refer to Malfunction 104, STEPS 1 and 2.

132. No air pressure at out regulator when control lever in Astern Throttle. Lever at least 20° in the Astern Position from Center.

STEP 1. Refer to Malfunction 104, STEPS 1 and 2 and Malfunction 105, STEP 1.

133. No air pressure at inlet port of station selector valve (four-way directional valve).

STEP 1. Check to see if air compressor is on.  
Turn on air compressor, TM 55-1905-223-10.

STEP 2. Check for defective air prep system.  
Repair/Replace air prep system, para. 2-121.



Table 2-2. Troubleshooting - CONT

---

Malfunction
Test or Inspection
Corrective Action

---

**ENGINE ROOM CONTROL STATION - CONT**

134. No air pressure at port # 1 when station selector valve is in Pilot House position.

STEP 1. Check to see if air compressor is on.  
Turn air compressor on, TM 55-1905-223-10.

STEP 2. Check for defective air prep system.  
Repair/Replace air prep station, para. 2-121.

STEP 3. Check for defective linear directional control valve (four-way transfer valve).  
Replace linear directional control valve, para 2-125.

STEP 4. Check for defective station selector valve (four-way directional valve).  
Replace four-way directional valve, para 2-118.

135. No air pressure at port #2 when station selector valve is in Engine Room Position.

STEP 1. Check to see if air compressor is on.  
Turn air compressor on, TM 55-1905-223-10.

STEP 2. Check for defective air prep system.  
Repair/Replace air prep station, para. 2-121.

STEP 3. Check for defective linear directional control valve (four-way transfer valve).  
Replace linear directional control valve, para. 2-125.

STEP 4. Check for defective station selector valve (four-way directional valve).  
Replace four-way directional valve, para 2-118.

136. Station selector valve still inoperative.

Replace station selector valve (four-way directional valve), para. 2-96.

**BOWTHRUSTER/FIRE PUMP CONTROL SYSTEM****NOTE**

Refer to Figure 2-1 and Table 2-3 for normal indications.

Table 2-2. Troubleshooting - CONT

---

Malfunction

Test or Inspection

Corrective Action

---

**BOWTHRUSTER/FIRE PUMP CONTROL SYSTEM- CONT**

137. No air pressure at inlet (supply port #2) when control lever in neutral position.
- STEP 1. Check to see if air compressor is on.  
Turn air compressor on. TM 55-1905-223-10.
- STEP 2. Check for defective linear directional control valve (4-way transfer valve).  
Repair/replace linear directional control valve, para. 2-125.
- STEP 3. Check for defective air prep system.  
Repair/replace air prep system, para. 2-121.
138. Control station does not respond when control lever in bowthruster control position.
- STEP 1. Check for defective roller operated valve.  
Replace roller operated valve, para. 2-126.
- STEP 2. Check for defective bowthruster cylinder.  
Repair/replace bowthruster cylinder, para. 2-126.
- STEP 3. Check for defective four-way transfer valve.  
Replace four-way transfer valve, para. 2-126.
- STEP 4. Defective control station.  
Replace control station, para 2-116.
139. RPM's do not increase when control lever in bowthruster control position.
- STEP 1. Check for defective governor actuator (throttle actuator).  
Replace governor actuator, para. 2-123.
- STEP 2. Check for defective bowthruster engine.  
Refer to Bowthruster Engine Manual, TM 55-1905-223-24-s.
140. Control station does not respond when control lever in fire pump control position.
- STEP 1. Check for defective roller operated valve.  
Replace roller operated valve, para. 2-126.
- STEP 2. Check for defective fire pump cylinder.  
Repair/replace fire pump cylinder, pare. 2-126.

Table 2-2. Troubleshooting - CONT

---

Malfunction	Test or Inspection	Corrective Action
-------------	--------------------	-------------------

---

**BOWTHRUSTER/FIRE PUMP CONTROL SYSTEM - CONT**

STEP 3. Check for defective four-way transfer valve.  
Replace four-way transfer valve, para 2-126.

STEP 4. Defective control station.  
Replace control station, para 2-116.

141. RPM's do not decrease when control lever in fire pump control position.

STEP 1. Check for defective governor actuator (throttle actuator).  
Replace governor actuator, para. 2-123.

STEP 2. Check for defective bow thruster engine.  
Refer to Bowthruster Engine Manual, TM 55-1905-223-24-S.

**GEAR MATE CONTROL SYSTEM****NOTE**

Refer to Figure 2-1 and Table 2-3 for normal indications.

142. Control lever in Neutral Stand-By. Air pressure at ports, 1, 2, 3, 4, 5, and 6 of three-way valves. Red pins at bottom of valves down or extended.

STEP 1. Check for defective directional control rotary valve.  
Repair/replace directional control rotary valve, para. 2-117.

143. Control lever in Ahead Throttle (Initial). No air pressure at port #1 of three-way valve. Red pin on valve #1 down or extended.

STEP 1. Check for defective exhaust valve.  
Replace exhaust valve, para. 2-119.

STEP 2. Check for defective shuttle valve.  
Replace shuttle valve, para. 2-119.

144. Control lever in Ahead Throttle (Initial). Air pressure at port #2 of three-way valve. Red pin on valve #1 down or extended.

STEP 1. Check for defective directional control rotary valve.  
Repair/replace directional control rotary valve, para. 2-117.

Table 2-2. Troubleshooting - CONT

---

Malfunction	Test or Inspection	Corrective Action
-------------	--------------------	-------------------

---

**GEAR MATE CONTROL SYSTEM - CONT**

145. Control lever in Ahead Throttle (Initial). Air pressure at port #3 of three-way valve. Red pin on valve #1 down or extended.

STEP 1. Check adjustment of valves.  
Adjust valves, para. 2-117.

STEP 2. Check for defective directional control rotary valve.  
Repair/replace directional control rotary valve, 2-117.

146. Control lever in Ahead Throttle (Initial). No air pressure at port #4 of three-way valve. Red pin on valve #2 up or retracted.

STEP 1. Check valves, para. 2-119.  
Adjust valves, para. 2-119.

STEP 2. Check for defective three-way valve.  
Repair/replace three-way valve, para. 2-119.

STEP 3. Check for defective directional control rotary valve.  
Repair/replace directional control rotary valve, para. 2-117.

STEP 4. Refer to Malfunction 75, STEPS 2 thru 8.

147. Control lever in Ahead Throttle (Initial). No air pressure at port #5 of three-way valve. Red pin on valve #2 up or retracted.

STEP 1. Refer to Malfunction 146, STEPS 1 and 2.

148. Control lever in Ahead Throttle (Initial). Air pressure at port #6 of three-way valve. Red pin on valve #2 up or retracted.

STEP 1. Check adjustment of valves.  
Adjust valves, para. 2-119.

STEP 2. Check for defective three-way valve.  
Repair/replace three-way valve, para. 2-119.

Table 2-2. Troubleshooting - CONT

## Malfunction

Test or Inspection  
Corrective Action

**GEAR MATE CONTROL SYSTEM - CONT**

149. Control lever in Ahead Throttle (After Delay). No air pressure at port #1 of three-way valve. Red pin on valve #1 down or extended.

STEP 1. Check for defective directional control rotary valve.  
Repair/Replace direction control rotary valve, para. 2-117.

150. Control lever in Ahead Throttle (After Delay). Air pressure at port #2 of three-way valve. Red pin on valve #1 down or extended.

STEP 1. Refer to Malfunction 144, STEPS 1 and 2.

151. Control lever in Ahead Throttle (After Delay). Air pressure at port #3 of three-way. Red pin on valve #1 down or extended.

STEP 1. Check for defective directional control rotary valve.  
Repair/Replace direction control rotary valve, para. 2-117.

152. Control lever in Ahead Throttle (After Delay). No air pressure at port #4 of three-way valve. Red pin on valve #2 up or retracted.

STEP 1. Refer to Malfunction 145, STEPS 1 and 2.

153. Control lever in Ahead Throttle (After Delay). No air pressure at port #5 of three-way valve, Red pin on valve #2 up or retracted.

STEP 1. Refer to Malfunction 146, STEP 1.

154. Control lever in Ahead Throttle (After Delay). Air pressure at port #6 of three-valve. Red pin on valve #2 up or retracted.

STEP 1. Check for defective directional control rotary valve.  
Repair/Replace direction control rotary valve, para. 2-117.

155. Control lever in Neutral (Astern Delay Mode). Air pressure at port #1 of three-way valve. Red pin on valve #1 down or extended.

STEP 1. Check adjustment of valves.  
Adjust valves, para. 2-119.

STEP 2. Check for defective three-way valves.  
Repair/replace three-way valves, para. 2-119.

STEP 3. Check for defective directional control rotary valve.  
Repair/replace directional control rotary valve, para. 2-117.

Table 2-2. Troubleshooting - CONT

---

Malfunction	Test or Inspection	Corrective Action
-------------	--------------------	-------------------

---

**GEAR MATE CONTROL SYSTEM - CONT**

156. Control lever in Neutral (Astern Delay Mode). Air pressure at port #2 of three-way valve. Red pin on valve #1 down or extended.
- STEP 1. Refer to Malfunction 145, STEPS 1 and 2.
157. Control lever in Neutral (Astern Delay Mode). Air pressure at port #3 of three-way valve. Red pin on valve #1 down or extended.
- STEP 1. Refer to Malfunction 145, STEPS 1 and 2.
158. Control lever in Neutral (Astern Delay Mode). Air pressure at port #4 of three-way valve. Red pin on valve #2 up or retracted.
- STEP 1. Refer to Malfunction 145, STEPS 1 and 2.
159. Control lever in Neutral (Astern Delay Mode). Air pressure at port #5 of three-way valve. Red pin on valve #2 up or retracted.
- STEP 1. Check for defective three-way valve.  
Replace three-way valve, para. 2-119.
- STEP 2. Check for defective directional control rotary valve.  
Replace/repair directional control rotary valve, para. 2-117.
160. Control lever in Neutral (Astern Delay Mode). Air pressure at port #6 of three-way valve. Red pin on valve #2 up or retracted.
- STEP 1. Refer to Malfunction 159, STEPS 1 and 2.
161. Control lever in Astern Throttle (Initial). Air pressure at port #1 of three-way valve. Red pin on valve #1 up or retracted.
- STEP 1. Repair/replace engine room control station, para. 2-117.
162. Control lever in Astern Throttle (Initial). No air pressure at port #2 of three-way valve. Red pin on valve #1 up or retracted.
- STEP 1. Check for defective shuttle valve.  
Replace shuttle valve, para. 2-119.
- STEP 2. Check for defective directional control rotary valve.  
Repair/replace directional control rotary valve.
- STEP 3. Refer to Malfunction 75, STEPS 1 thru 8.

Table 2-2. Troubleshooting - CONT

## Malfunction

Test or Inspection

Corrective Action

**GEAR MATE CONTROL SYSTEM - CONT**

163. Control lever in Astern Throttle (Initial). No air pressure at port #3 of three-way valve. Red pin on valve #1 up or retracted.
- STEP 1. Check adjustment of valves.  
Adjust valves, para. 2-119.
- STEP 2. Check for defective three way valve.  
Repair/replace three-way valve, para. 2-119.
164. Control lever in Astern Throttle (Initial). Air pressure at port #4 of three-way valve. Red pin on valve #2 down or extended.
- STEP 1. Check for defective three way valve.  
Repair/replace three-way valve, para. 2-119.
- STEP 2. Check for defective directional control rotary valve.  
Repair/replace directional control rotary valve, para. 2-117.
165. Control lever in Astern Throttle (Initial). Air pressure at port #5 of three-way valve. Red pin on valve #2 down or extended.
- STEP 1. Refer to Malfunction 154, STEPS 1 and 2 and Malfunction 162, STEP 2.
166. Control lever in Astern Throttle (Initial). No air pressure at port #6 of three-way valve. Red pin on valve #2 down or extended.
- STEP 1. Repair/replace engine room control station, para. 2-117.
167. Control lever in Astern Throttle (After Delay). Air pressure at port #1 of three-way valve. Red pin on valve #1 up or retracted.
- STEP 1. Repair/replace engine room control station, para. 2-117.
168. Control lever in Astern Throttle (After Delay). No air pressure at port #2 of three-way valve. Red pin on valve #1 up or retracted.
- STEP 1. Repair/replace engine room control station, para. 2-117.
169. Control lever in Astern Throttle (After Delay). No air pressure at port #3 of three-way valve. Red pin on valve #1 up or retracted.
- STEP 1. Check for defective directional control rotary valve.  
Repair/replace directional control rotary valve, para. 2-117.

Table 2-2. Troubleshooting - CONT

---

Malfunction	Test or Inspection	Corrective Action
-------------	--------------------	-------------------

---

**GEAR MATE CONTROL SYSTEM - CONT**

170. Control lever in Astern Throttle (After Delay). Air pressure at port #4 of three-way valve. Red pin on valve #2 down or extended.

STEP 1. Check for defective three-way valve.  
Repair/replace three-way valve, para. 2-119.

STEP 2. Check for defective directional control rotary valve.  
Repair/replace directional control rotary valve, para. 2-117.

171. Control lever in Astern Throttle (After Delay). Air pressure at port #5 of three-way valve. Red pin on valve #2 down or extended.

STEP 1. Refer to Malfunction 170, STEPS 1 and 2.

172. Control lever in Astern Throttle (After Delay). No air pressure at port #6 of three-way valve. Red pin on valve #2 down or extended.

STEP 1. Refer to Malfunction 170, STEPS 1 and 2.

**THROTTLE INTERLOCK**

**NOTE**

Refer to Figure 2-1 and Table 2-3 for normal indications.

173. No air pressure at (IN) port of throttle interlock.

STEP 1. Check for defective shuttle valve.  
Replace shuttle valve, para. 2-119.

STEP 2. Check for defective directional control rotary valve.  
Repair/Replace directional control rotary valve, para. 2-117.

174. No air pressure at (OUT) port of throttle interlock.

STEP 1. Check for defective throttle interlock.  
Repair/Replace throttle interlock, para. 2-119.

175. No oil pressure at (OIL) port of throttle interlock.

STEP 1. Check to see if reduction gear is in Neutral position.  
Ensure reduction gear is in Ahead or Astern position.



Table 2-2. Troubleshooting - CONT

---

Malfunction	Test or Inspection	Corrective Action
-------------	--------------------	-------------------

---

**THROTTLE INTERLOCK - CONT**

176. No air pressure at (AIR) port of throttle interlock.

STEP 1. Check for defective shuttle valve.  
Replace shuttle valve, para. 2-119.

STEP 2. Check for defective three-way valve.  
Repair/Replace three-way valve, para. 2-119.

STEP 3. Check for defective directional control rotary valve.  
Repair/Replace directional control rotary valve, para. 2-117.

STEP 4. Refer to Malfunction 75, STEPS 2 thru 8).

177. No air pressure at (VENT) port of throttle interlock.

STEP 1. Check for defective throttle interlock.  
Repair/Replace throttle interlock, para. 2-119.

178. No air at throttle actuator.

STEP 1. Check that reduction gear is engaged.  
Refer to TM 55-1905-223-10.

STEP 2. Check for defective throttle interlock.  
Repair/replace throttle interlock, para. 2-119.

STEP 3. Check for defective shuttle valve.  
Replace shuttle valve, para. 2-119.

STEP 4. Check for defective three-way valve.  
Repair/replace three-way valve, para. 2-119.

**GEAR ACTUATOR****NOTE**

Refer to Figure 2-1 and Table 2-3 for normal indications.

179. Control lever in Neutral Stand-By. Air pressure at Ahead port of gear actuator.

STEP 1. Check for defective directional control rotary valve.  
Repair/Replace directional control rotary valve, para. 2-117.

Table 2-2. Troubleshooting - CONT

---

Malfunction

Test or Inspection  
Corrective Action

---

**GEAR ACTUATOR- CONT**

180. Control lever in Neutral Stand-By. Air pressure at Astern port of gear actuator.
- STEP 1. Check for defective shuttle valve.  
Replace shuttle valve, para. 2-119.
- STEP 2. Check for defective three-way valve.  
Repair/replace three-way valve, para. 2-119.
- STEP 3. Check for defective directional control rotary valve.  
Repair/replace directional control rotary valve, para. 2-117.
181. Control lever in Ahead Throttle (Initial). No air pressure at Ahead port of gear actuator.
- STEP 1. Check for defective three-way valve.  
Repair/Replace three-way valve, para. 2-119.
- STEP 2. Check for defective shuttle valve.  
Replace shuttle valve, para. 2-119.
- STEP 3. Check for defective directional control rotary valve.  
Repair/replace directional control rotary valve, para. 2-117.
- STEP 4. Refer to Malfunction 75, STEPS 2 thru 8.
182. Control lever in Ahead Throttle (Initial). Air pressure at Astern port of gear actuator.
- STEP 1. Refer to Halffunction 180, STEPS 1 thru 3.
183. Control lever in Ahead Throttle (After Delay). No air pressure at Ahead port of gear actuator.
- STEP 1. Refer to Malfunction 181, STEPS 1 thru 4.
184. Control lever in Ahead Throttle (After Delay). Air pressure at Astern port of gear actuator.
- STEP 1. Refer to Malfunction 180, STEPS 1 thru 3.

Table 2-2. Troubleshooting - CONT

---

Malfunction	Test or Inspection	Corrective Action
-------------	--------------------	-------------------

---

**GEAR ACTUATOR - CONT**

185. Control lever in Neutral-Astern Delay. Air pressure at Ahead port of gear actuator.  
STEP 1. Refer to Malfunction 180, STEPS 1 thru 3.
186. Control lever in Neutral-Astern Delay. Air pressure at Astern port of gear actuator.  
STEP 1. Refer to Malfunction 180, STEPS 1 thru 3.
187. Control lever in Astern Throttle (Initial). Air pressure at Ahead port of gear actuator.  
STEP 1. Refer to Malfunction 180, STEPS 1 thru 3.
188. Control lever in Astern Throttle (Initial). No air pressure at Astern port of gear actuator.  
STEP 1. Refer to Malfunction 181, STEPS 1 thru 4.
189. Control lever in Astern Throttle (After Delay). Air pressure at Ahead port of gear actuator.  
STEP 1. Refer to Malfunction 180, STEPS 1 thru 3.
190. Control lever in Astern Throttle (After Delay). No air pressure at Astern port of gear actuator.  
STEP 1. Refer to Malfunction 181, STEPS 1 thru 4.

**GOVERNOR ACTUATOR**

**NOTE**

Refer to Figure 2-1 and Table 2-3 for normal indications.

191. Control lever in Neutral Stand-By. Governor actuator in extended position.  
STEP 1. Check for defective throttle interlock.  
Repair/Replace throttle interlock. para. 2-119.

Table 2-2. Troubleshooting - CONT

---

Malfunction

Test or Inspection

Corrective Action

---

**GOVERNOR ACTUATOR - CONT**

STEP 2. Check for defective governor actuator.

Repair governor actuator, para. 2-123.

192. Control lever in Ahead Throttle (Initial). Governor actuator in retracted position.

STEP 1. Check for defective governor actuator.

Repair/replace governor actuator, para. 2-123.

STEP 2. Check for defective throttle interlock.

Repair/replace throttle interlock, para. 2-119.

STEP 3. Check for defective three-way valve.

Repair/replace three-way valve, para. 2-119.

STEP 4. Check for defective directional control rotary valve.

Repair/replace directional control rotary valve, para. 2-117.

193. Control lever in Neutral-Astern Delay. Governor actuator in extended position.

STEP 1. Refer to Malfunction 191, STEPS 1 and 2.

194. Control lever in Astern Throttle (Initial). Governor actuator in extended position.

STEP 1. Refer to Malfunction 191, STEPS 1 and 2.

**BRAKE PANEL ASSEMBLY**

**NOTE**

Refer to Figure 2-1 and Table 2-3 for normal indications.

195. No pressure at port #1 of brake panel.

STEP 1. Check to see if air compressor is on.

Turn on air compressor, TM 55-1905-223-10.

STEP 2. Check for defective air prep system.

Repair/Replace air prep system, para. 2-121.

Table 2-2. Troubleshooting - CONT

---

Malfunction	Test or Inspection	Corrective Action
-------------	--------------------	-------------------

---

### BRAKE PANEL ASSEMBLY - CONT

196. No air pressure at port #2 of brake panel.
- STEP 1. Check for defective shuttle valve.  
Replace shuttle valve, para. 2-119.
- STEP 2. Refer to Gear Mate Control System Troubleshooting procedures.
197. No (OUT) air pressure at port #3 of break panel.
- STEP 1. Check for defective brake panel assembly.  
Repair/Replace brake panel assembly, para. 2-122.

### BATTERY CHARGER

198. No output.
- STEP 1. Check fuse.  
Replace fuse, para. 2-195.
- STEP 2. Check electrical cables.  
Tighten or repair/replace.
- STEP 3. Check for defective battery charger.  
Replace battery charger, para. 2-195.

### BATTERY

199. Battery will not charge.
- STEP 1. Check terminals.  
Clean terminals.
- STEP 2. Check electrolyte.  
Add electrolyte as required.
- STEP 3. Check for defective cells.  
Use a multimeter and check cell voltage.
200. Battery will not hold charge.
- STEP 1. Check electrolyte.  
Use a hydrometer, to check specific gravity of electrolyte.

Table 2-2. Troubleshooting - CONT

---

Malfunction	Test or Inspection	Corrective Action
-------------	--------------------	-------------------

---

**BATTERY - CONT**

STEP 2. Check for dead cell.  
Use a multimeter and check each cell.

**MOTOR CONTROLLERS**

201. No power.

STEP 1. Check for open fuse.  
Replace fuse, para. 2-223.

STEP 2. Using a multimeter, check circuit breaker.  
Replace circuit breaker, para. 2-223.

STEP 3. Check for loose or broken electrical power cables.  
Tighten or repair/replace broken electrical power cables.

**POWER DISTRIBUTION PANELS**

202. No power.

STEP 1. Check for open circuit breaker.  
Reset circuit breaker.

STEP 2. Check for loose or broken electrical power cable.  
Tighten or repair/replace electrical power cables.

STEP 3. Using a multimeter, check for broken electrical power cable between  
main switchboard and power distribution panel.  
Repair/replace electrical power cable.

203. Fluorescent, incandescent or floodlight does not work.

STEP 1. Check light bulb.  
Replace burnt out bulb.

STEP 2. Check circuit breaker at power distribution panel.  
Reset circuit breaker.

STEP 3. Using a multimeter, check electrical power cables between power  
distribution panel and fixture.  
Repair/replace electrical power cable.

Table 2-2. Troubleshooting - CONT

---

Malfunction  
 Test or Inspection  
 Corrective Action

---

**POWER DISTRIBUTION PANELS - CONT**

- STEP 4. Using a multimeter, check electrical power cable between main switchboard and power distribution panel.  
 Repair/replace electrical power cable.

**ELECTRCAL RECEPTACLE**

204. No power output.

- STEP 1. Check receptacle contacts.  
 a. Clean contacts.  
 b. Replace receptacle.

- STEP 2. Using a multimeter, check electrical power cable between power distribution panel and receptacle.  
 Repair/replace electrical power cable.

**ELECTRICAL SELF GENERATING TACHOMETER (SHAFT)**

205. No speed/direction indication on either wheelhouse console or engine control station console PORT shaft tachometer.

- STEP 1. Check ENGINE RM DC PNL EP024 fuse cartridge 14, SPT TACH (PORT).  
 Replace fuse cartridge. Refer to paragraph 2-307.

- STEP 2. Check port shaft motional pickup transducer to see if flats or motional pickup transducer are parallel to propeller shaft flange.  
 Adjust port motional pickup transducer. Refer to paragraph 2-307.

- STEP 3. Inspect port shaft motional pickup transducer for obvious damage.  
 Refer to paragraph 2-307.  
 Replace port motional pickup transducer. Refer to paragraph 2-307.

206. No speed/direction indication on either wheelhouse console or engine control station console STBD shaft tachometer.

- STEP 1. Check ENGINE RM DC PNL EP024 fuse cartridge 13, SFT TACH (STBD).  
 Replace fuse cartridge. Refer to paragraph 2-307.

- STEP 2. Check starboard shaft motional pickup transducer to see if flats or motional pickup transducer are parallel to propeller shaft flange.  
 Adjust starboard motional pickup transducer. Refer to paragraph 2-307.

- STEP 3. Inspect starboard motional pickup transducer for obvious damage.  
 Replace starboard motional pickup transducer. Refer to paragraph 2-307.

Table 2-2. Troubleshooting - CONT

---

Malfunction

Test or Inspection

Corrective Action

---

ELECTRICAL SELF GENERATING TACHOMETER (SHAFT) - CONT

207. No speed/direction indication on one wheelhouse console or one engine control station console shaft tachometer.

STEP 1. Inspect shaft tachometer arbitrary scale or meter for broken cover, bent needle, or other obvious damage.  
Replace arbitrary scale meter. Refer to paragraph 2-307.

208. No illumination on both wheelhouse console shaft tachometer arbitrary scale meters.

STEP 1. Check 24 vdc supply at shaft tachometer arbitrary scale meters.  
Reset circuit breaker on 24 vdc supply to shaft tachometer arbitrary scale meters.

209. Unable to dim one wheelhouse console shaft tachometer arbitrary scale meter illumination.

STEP 1. Using screwdriver, check dimmer rheostat on wheelhouse console shaft tachometer for smooth operation.  
Replace dimmer rheostat. Refer to paragraph 2-307.

VALVES AND STRAINERS

210. Valve gasket leaking.

STEP 1. Check for security of fittings.  
Replace gasket or valve. Refer to Index for procedures for particular valve.

211. No flow or limited flow through strainer.

STEP 1. Check for clogged strainer.  
a. Clean strainer.  
b. Replace strainer element or basket.  
c. Replace strainer.  
(Refer to Index for procedures for particular strainer.)

212. Strainer leaking.

STEP 1. Check for clogged strainer.  
a. Clean strainer.  
b. Replace strainer element or basket.  
(Refer to Index for procedures for particular strainer.)



Table 2-2. Troubleshooting - CONT

---

Malfunction  
 Test or Inspection  
 Corrective Action

---

**VALVES AND STRAINERS - CONT**

- STEP 2. Check for worn gasket or preformed packing.  
 a. Replace gasket or packing.  
 b. Replace strainer.  
 (Refer to Index for procedures for particular strainer.)

**POTABLE WATER PIPING SYSTEM**

213. Low discharge pressure.

- STEP 1. Check for low liquid level in fresh water tank (air vortexing into suction).  
 Check valve alignment. Realign valve to access other tank (TM 55-1905-223-10).

- STEP 2. Check for partially closed suction valve.  
 Ensure suction valve is fully open.

- STEP 3. Check for partially closed discharge valve.  
 Ensure discharge valve is fully open.

- STEP 4. Check for sticking valves.

**NOTE**

- a. The main cause of a sticking valve stem is overtight packing.  
 To loosen the stem, slack up the gland.
- b. Check that the gland is not binding the stem.
- c. If this is the case, correct the position of the gland by adjusting the gland nuts.
- d. Paint or other foreign matter on the valve stem can cause sticking.
- e. Remove paint or foreign matter by cleaning.
- f. If the valve is jammed open or shut, release the jam by using the handwheel.
- g. If the valve jam cannot be released. Replace valve (para. 2-319).
- h. If the valve stem is bent or the threads are burred/stripped. Repair/Replace valve (para. 2-319).

- STEP 5. Check for leaking lines, fittings, or connections.  
 Inspect all lines, tighten connections and fittings as necessary.

Table 2-2. Troubleshooting - CONT

---

Malfunction  
Test or Inspection  
Corrective Action

---

**POTABLE PIPING SYSTEM - CONT**

- STEP 6. Check for leaking valves.
- a. Leakage through stuffing-box packing.
    - (1) Tighten the gland.
    - (2) If the gland has entered the stuffing-box to an extent that there is no remaining adjustment. Repack packing gland.
  - b. Leakage across valve seats.

**NOTE**

Leakage across the valve seats may be due to foreign matter lodged in the seats.

- (1) Occasionally foreign matter can be flushed away by allowing normal flow of water through the valve.
- (2) If the leakage continues. Repair valve.

STEP 7. Check for defective hydropneumatic pressure tank.  
Inspect for leaks, excessive corrosion, security, and general condition of tank.

STEP 8. Check valve jammed by foreign matter.  
Remove valve (para. 2-319).

- b. Inspect and clean as necessary.

STEP 9. Check for malfunctioning pressure gauge.

- a. Test the gauge as follows:
  - (1) Remove gauge from system (para. 2-321).
  - (2) Install a gauge of known accuracy to check system.
  - (3) Replace faulty gauge (para. 2-321).

STEP 10. Check for defective pressure switches.  
Replace pressure switch (para. 2-322).

STEP 11. Pump casing or discharge line partially clogged or damaged.  
Clean pump casing.

- b. Clean or replace discharge line.

STEP 12. Check pump for wrong direction or rotation.

**CAUTION**

Serious damage can result if the pump is operated with incorrect rotation.

Table 2-2. Troubleshooting - CONT

---

Malfunction

Test or Inspection

Corrective Action

---

**POTABLE WATER PIPING SYSTEM - CONT**

- a. Check that the pump operates in the direction indicated by the arrow on the pump casing.

**NOTE**

Make sure the shaft rotation is clockwise when looking at the motor end of the pump.

- b. Check all electrical connections to motor.
- c. Check source voltage, phase, and frequency applied to motor as to specifications listed on motor name plate/decal.
- STEP 13. Pump speed too low.
- a. Check motor input, make sure motor is receiving full voltage and frequency.
- b. Check voltage, phase, and frequency on motor with specifications on motor nameplate.

STEP 14. Pump impeller clogged or damaged.  
Repair/replace pump, para. 2-95.

STEP 15. Shaft seal assembly/impeller binding.

a. Check for freedom of rotation by momentarily starting the motor and listening for rubbing sound.

b. If rubbing sound is detected:  
Replace/repair pump, para. 2-95.

214. No discharge pressure.

STEP 1. Check for closed discharge valve.  
Ensure discharge valve is fully open.

STEP 2. Check for closed suction valve.  
Ensure suction valve is fully open.

STEP 3. Check valve installed backwards or jammed.

a. Ensure check valve is installed in correct direction with stem in the upright position.

b. If valve is jammed, refer to Malfunction 216, Step 10.

STEP 4. Check for pump casing vapor lock (cavitation).

Table 2-2. Troubleshooting - CONT

---

Malfunction
Test or Inspection
Corrective Action

---

POTABLE WATER PIPING SYSTEM - CONT

**NOTE**

If cavitation or vapor lock should occur, widely fluctuating discharge pressure will be noted.

- a. Prime pump as follows:
  - (1) Push stop button on engine room console panel.
  - (2) Remove casing vent plug.
  - (3) Fill casing with water and install vent plug.
  - (4) fill suction piping with water.

**NOTE**

Suction piping must be completely full to get a good prime.

- (5) Operate pump. Push start button on engine room console panel.

STEP 5. Pump casing or discharge line clogged.

- a. Clean pump casing.
- b. Clean or replace discharge line.

STEP 6. Check pump for wrong direction of rotation.

Refer to Malfunction 216, Step 14.

STEP 7. Pump speed too low.

Refer to Malfunction 216, Step 15.

STEP 8. Pump not rotating.

- a. Check for open pump motor circuit breaker. Reset circuit breaker at Main Switchboard.
- b. Check for defective motor controller. Refer to MOTOR CONTROLLER troubleshooting Malfunction 201, Steps 1 through 3.
- c. Check for defective pressure switches. Refer to Malfunction 216, Step 12.
- d. Check all electrical connections to motor.
- e. Check voltage, phase, and frequency on motor with specifications on motor nameplate.

STEP 9. Pump impeller clogged or damaged.

- a. Replace pump, para 2-95.

215. No hot water.

Table 2-2. Troubleshooting - CONT

---

Malfunction
Test or Inspection
Corrective Action

---

POTABLE WATER PIPING SYSTEM - CONT

STEP 1. Check for open hot water heater circuit breaker.  
Reset circuit breaker at Main Switchboard.

STEP 2. Check for closed inlet/outlet valve.  
Ensure valves are open.

## NOTE

Remove power from hot water heater when using an ohmmeter for continuing checks.

STEP 3. Use ohmmeter to check disconnect switch.  
Replace/repair disconnect switch as necessary (para. 2-168).

STEP 4. Check for loose or damaged electrical connections and cables.  
Repair electrical connections or cables as necessary.

STEP 5. Check heating element with ohmmeter for open/shorted element or grounded circuitry.  
Replace heating element as necessary (para. 2-328). Restore power to hot water heater at disconnect switch.

STEP 6. Check for hot water leakage.  
Make sure the drain valve is tightly closed.

- b. Check the relief valve outlet for leakage. Replace relief valve as necessary (para. 2-328).
- c. Examine the flange area of the heating elements for gasket leakage. Tighten bolts or replace gasket as necessary.

216. Excessive pump vibration.

STEP 1. Air in system.  
Bleed pump and suction line.

- b. Prime pump.

STEP 2. Check for loose or broken foundation bolts.  
Tighten or replace bolts (para. 2-95).

STEP 3. Check for pump/motor misalignment.  
Inspect pump and motor alignment with suction and discharge piping.

- be: Check all piping supports for security and effective loading,

Table 2-2. Troubleshooting - CONT

---

Malfunction
Test or Inspection
Corrective Action

---

**BILGE/BALLAST AND FIREMAN PIPING SYSTEM**

217. Low discharge pressure.

- STEP 1. Check for partially closed suction valve.  
Ensure suction valve is fully open.
- STEP 2. Check for open suction valve to empty bilge well.  
Align all suction valves on bilge manifold.
- STEP 3. Check for partially closed discharge valve.  
Ensure discharge valve is fully open.
- STEP 4. Check for dirty or clogged suction strainers.  
Clean or replace strainers.
- STEP 5. Check for sticking valves.  
Refer to POTABLE WATER SYSTEM troubleshooting, Malfunction 216, Step 6.
- STEP 6. Check for leaking valves.  
Refer to POTABLE WATER SYSTEM troubleshooting, Malfunction 216, Step 8.
- STEP 7. Check for leaking flange joints or loose flange connections.

**NOTE**

It is best to tighten the joints while under pressure so that leak stoppage can be observed.

- a. Inspect and tighten connection.
  - b. If uniform tightening does not stop the leak.
  - c. Isolate the joint and release line pressure.
  - d. Check for leaking pipe fitting. Locate leak, isolate repair or replace fitting (para. 2-320).
  - e. Restore seating surfaces by polishing with crocus cloth.
  - f. Install a new gasket and tighten bolts uniformly.
  - g. If leakage continues, repair valve.
- STEP 8. Check for piping failure.  
Locate leak, isolate repair or replace affected piping (para. 2-320).
- STEP 9. Check for leaking pipe fitting.  
Locate leak, isolate repair or replace fitting (para. 2-320).

Table 2-2. Troubleshooting - CONT

---

Malfunction  
 Test or Inspection  
 Corrective Action

---

**BILGE/BALLAST AND FIREMAIN PIPING SYSTEM - CONT**

STEP 10. Check valve jammed by foreign matter.

- a. Remove valve (para. 2-329).
- b. Inspect and clean as necessary.
- c. Replace valve (para. 2-329).

STEP 11. Check for defective relief valve.

Isolate, repair or replace valve (para. 2-329).

STEP 12. Check for leakage in firemain connections.

Isolate, repair or replace connection.

STEP 13. Check for leaking valve at fire station.

Locate station, isolate, repair or replace valve.

STEP 14. Check for defective fire pumps.

Refer to FIRE PUMP troubleshooting.

STEP 15. Check for malfunctioning pressure gauge.

- a. Test the gauge as follows:
  - (1) Remove gauge from system (para. 2-335).
  - (2) Install a gauge of known accuracy to check system.
  - (3) Replace faulty gauge (para. 2-335).

STEP 16. Check for worn or defective bilge pump.

Refer to BILGE/BALLAST PUMP troubleshooting (TM 55-1905-223-24-13).

218. No discharge pressure.

STEP 1. Check for closed suction valve.

Ensure suction valve is fully open.

STEP 2. Check for closed discharge valve.

Ensure discharge valve is fully open.

STEP 3. Pump not primed.

Prime pump.

STEP 4. Check for closed discharge pressure gauge cutout valve.

Open discharge pressure gauge cutout valve.

STEP 5. Check valve installed backwards or jammed.

- a. Ensure check valve is installed in correct direction with stem in the upright position.
- b. If valve is jammed, refer to Malfunction 219, STEP 9.

Table 2-2. Troubleshooting - CONT

---

Malfunction  
Test or Inspection  
Corrective Action

---

**BILGE/BALLAST AND FIREMAIN PIPING SYSTEM - CONT**

STEP 6. Check for open BILGE PUMP MOTOR circuit breaker at Main Switchboard.  
Reset circuit breaker.

STEP 7. Check for defective motor controller.  
Refer to MOTOR CONTROLLER troubleshooting Malfunction 201, STEPS 1 through 3.

STEP 8. Check for worn or defective bilge pump.  
Refer to BILGE/BALLAST PUMP troubleshooting (TM 55-1905-223-24-13).

**SEAWATER COOLING PIPING SYSTEM**

219, Low discharge pressure.

STEP 1. Check for partially closed suction valves.  
Ensure suction valve is fully open.

STEP 2. Check for partially closed discharge valve.  
Ensure discharge valve is fully open.

STEP 3. Check for dirty or clogged duplex strainer.  
a. Isolate strainer.  
b. Clean or replace strainer basket.

STEP 4. Check for sticking valves.  
Refer to POTABLE WATER SYSTEM troubleshooting, Malfunction 1, Step 6.

STEP 5. Check for leaking valves.  
Refer to POTABLE WATER SYSTEM troubleshooting, Malfunction 1, Step 8.

STEP 6. Check for leaking flange joints or loose flange connections.  
Refer to BILGE/BALLAST AND FIREMAIN SYSTEM troubleshooting, Malfunction 1, Step 7.

STEP 7. Check for piping failure.  
Locate leak, isolate repair or replace affected piping.

STEP 8. Check for leaking pipe fitting.  
Locate leak, isolate repair or replace fitting (para. 2-336).



Table 2-2. Troubleshooting - CONT

---

Malfunction	Test or Inspection	Corrective Action
-------------	--------------------	-------------------

---

## SEAWATER COOLING PIPING SYSTEM - CONT

- STEP 9. Check for malfunctioning pressure gauge.
- a. Test the gauge as follows:
    - (1) Remove gauge from system (para. 2-340).
    - (2) Install a gauge of known accuracy to check system.
    - (3) Replace faulty gauge (para. 2-340).

- STEP 10. Check valve jammed by foreign matter.
- a. Remove valve (para. 2-336).
  - b. Inspect and clean as necessary.
  - c. Replace valve (para. 2-336).

- STEP 11. Check for defective pressure relief valve.

**NOTE**

If pressure relief valve is defective, low pump suction pressure will be noted. Replace relief valve, para. 2-336.

- STEP 12. Check for partially clogged or damaged pump casing or pump discharge line.

- a. Clean pump casing.
- b. Clean or replace discharge line.

- STEP 13. Check pump for wrong direction of rotation.

Refer to POTABLE WATER PIPING SYSTEM troubleshooting Malfunction 1, Step 14.

- STEP 14. Pump speed too low.

- a. Check motor output, make sure motor is receiving full voltage and frequency.
- b. Check voltage, phase, and frequency on motor with specification on motor nameplate.

- STEP 15. Check for binding rotor impeller or seal.

- a. Check for freedom of rotation by momentarily starting the motor and listening for rubbing sound.
- b. Replace pump (para. 2-99).

220. No discharge pressure.

- STEP 1. Check for closed discharge valve.  
Ensure discharge valve is fully open.

Table 2-2. Troubleshooting - CONT

Malfunction

Test or Inspection  
Corrective Action

**SEAWATER COOLING PIPING SYSTEM - CONT**

STEP 2. Check for closed suction valve.  
Ensure suction valve is fully open.

STEP 3. Check valve installed backwards or jammed.  
a. Ensure check valve is installed in correct direction with stem in the upright position.  
b. If check valve is jammed:  
(1) Remove valve, (para. 2-336).  
(2) Inspect and clean as necessary.  
(3) Clean or replace strainer basket.

STEP 4. Check for clogged duplex strainer.  
a. Isolate strainer.  
b. Clean or replace strainer basket.

STEP 5. Check for pump casing vapor leak (cavitation).  
Refer to POTABLE WATER PIPING SYSTEM troubleshooting, Malfunction 2, Step 4.

STEP 6. Check for clogged or damaged pump casing or pump discharge line.  
Replace pump, para. 2-99.

STEP 7. Pump speed too low.  
Refer to POTABLE WATER PIPING SYSTEM troubleshooting, Malfunction 1, Step 11.

STEP 8. Pump not rotating.  
Refer to POTABLE WATER PIPING SYSTEM troubleshooting, Malfunction 2, Step 9.

221. Excessive pump vibration.

STEP 1. Air in system.  
a. Bleed pump and suction line.  
b. Prime pump. Refer to POTABLE WATER PIPING SYSTEM troubleshooting Malfunction 2, Step 4.

STEP 2. Check for loose or broken foundation bolts.  
Tighten or replace bolts.

STEP 3. Check for pump/motor misalignment.  
a. Inspect pump and motor alignment with suction and discharge piping.  
b. Shim unit as necessary.  
c. Check all piping supports for security and effective loading.

Table 2-2. Troubleshooting - CONT

---

Malfunction  
 Test or Inspection  
 Corrective Action

---

FRESH WATER COOLING PIPING SYSTEM

222. Low discharge pressure.

STEP 1. Check for partially closed suction valves.  
 Ensure suction valves are fully open.

STEP 2. Check for partially closed discharge valves.  
 Ensure discharge valves are fully open.

STEP 3. Check for dirty or clogged suction strainers.  
 Clean or replace strainers.

STEP 4. Check for sticking valves.  
 Refer to POTABLE WATER SYSTEM troubleshooting, Malfunction 1, Step 6.

STEP 5. Check for leaking valves.  
 Refer to POTABLE WATER SYSTEM troubleshooting, Malfunction 1, Step 8.

STEP 6. Check for leaking flange joints or loose flange connections.  
 Refer to BILGE/BALLAST AND FIREMAIN SYSTEM troubleshooting, Malfunction 1, Step 7.

STEP 7. Check for piping failure.  
 Locate leak, isolate repair or replace affected piping.

STEP 8. Check for leaking pipe fitting.  
 Locate leak, isolate repair or replace fitting.

STEP 9. Check for malfunctioning pressure gauge.  
 a. Test the gauge as follows:  
     (1) Remove gauge from system (para. 2-340).  
     (2) Install a gauge of known accuracy to check system.  
     (3) Replace faulty gauge (para. 2-340).

STEP 10. Check valve jammed by foreign matter.  
 a. Remove valve (para. 2-341).  
 b. Inspect and clean as necessary.  
 c. Replace valve (para. 2-341).

NOTE

If steps 1 through 10 do not correct the malfunction,  
 refer to POTABLE WATER SYSTEM troubleshooting.

Table 2-2. Troubleshooting - CONT

---

Malfunction	Test or Inspection	Corrective Action
-------------	--------------------	-------------------

---

FRESH WATER COOLING PIPING SYSTEM - CONT

223. No discharge pressure.

STEP 1. Check for closed discharge valve.  
Ensure discharge valve is fully open.

STEP 2. Check for closed suction valve.  
Ensure suction valve is fully open.

STEP 3. Check valve installed backwards or jammed.  
a. Ensure check valve is installed in correct direction with stem in the upright position.  
b. If check valve is jammed:  
(1) Remove valve (para. 2-341).  
(2) Inspect and clean as necessary.  
(3) Clean or replace strainer basket.

NOTE

If steps 1 through 3 do not correct the malfunction, refer to POTABLE WATER SYSTEM troubleshooting.

COMPRESSED AIR PIPING SYSTEM

224. System does not maintain pressure.

STEP 1. Check for leakage in mission essential equipment piping branch.  
a. Isolate one mission-essential supply branch at a time.  
b. If pressure begins to return, leave branch isolated.  
c. If pressure does not return, reopen branch and try another branch.  
d. Repair as necessary.

STEP 2. Check for leakage in utility branch piping.  
a. Isolate one branch at a time until pressure returns.  
b. When faulty area is located, repair as necessary.

STEP 3. Check for leaking receiver.  
a. Isolate receiver.  
b. Repair or replace faulty components as necessary.

Table 2-2. Troubleshooting - CONT

---

Malfunction

Test or Inspection

Corrective Action

---

COMPRESSED AIR PIPING SYSTEM - CONT

- STEP 4. Check for leaking moisture separator.
- a. Isolator separator.
  - b. Repair or replace as necessary.
- STEP 5. Check for defective pressure relief valves.
- a. Inspect relief valves.
  - b. Locate and isolate faulty valve.
  - c. Repair or replace valve.
- STEP 6. Check for defective air dryer.
- a. Inspect air dryer.
  - b. Isolate, repair or replace dryer. Refer to air compressor troubleshooting (TM 55-1905-223-24-8).
- STEP 7. Check for defective compressor.
225. Pressure loss in piping main. Piping main pressure gauges indicate low pressure (below 220 psig) and constant need to run compressors.
- STEP 1. Check for piping failure in piping main/piping branches or serviced equipment.
- a. Inspect piping.
  - b. Locate and isolate faulty piping.
  - c. Repair or replace as necessary (para 2-342).
- STEP 2. Check for relief valve failure in piping main/piping branches or serviced equipment.
- a. Inspect relief valve.
  - b. Locate and isolate faulty relief valve.
  - c. Repair or replace as necessary (para 2-342).
- STEP 3. Check for hose/connection failure to serviced equipment.
- a. Inspect hose connections.
  - b. Locate and isolate faulty hose/connections and replace as necessary (para. 2-342).
- STEP 4. Check for leaking air serviced equipment.
- a. Inspect equipment.
  - b. Locate and isolate faulty equipments.
  - c. Repair or replace as necessary.

Table 2-2. Troubleshooting - CONT

---

Malfunction	
Test or Inspection	
Corrective Action	

---

COMPRESSED AIR PIPING SYSTEM - CONT

STEP 5. If the above steps do not locate malfunction, isolate all branch piping.

- a. If pressure in main increases.
  - (1) Open one branch at a time until faulty branch is determined.
  - (2) Repair as necessary.

STEP 6. If step 5, above, fails to locate malfunction.

- a. Systematically isolate each section.
  - (1) Main deck.
  - (2) Below main deck.
- b. If isolating a specific section causes pressure in main to increase, repair the section as necessary (para. 2-342).

STEP 7. Check for malfunctioning compressor.  
Refer to air compressor troubleshooting (TM 55-1905-223-24-8).

226. Low or no pressure at serviced equipment. Low pressure indication at equipment pressure gauge. Main pressure gauge indicates normal pressure (220 psig).

STEP 1. Check for equipment or branch isolation valves completely or partially closed.  
Ensure that all valves to equipment are fully opened.

STEP 2. Check for malfunctioning pressure reducing valve.  
Repair or replace valve as necessary (para. 2-342).

STEP 3. Check for loss of pressure in piping main.  
Refer to malfunction 229.

227. Excessive moisture in system.

STEP 1. See if operator drained moisture separator.  
Drain separator of all moisture.

STEP 2. Check for defective air dryer.

- a. Inspect air dryer.
- b. Isolate, repair or replace dryer.

Table 2-2. Troubleshooting - CONT

---

Malfunction	
	Test or Inspection
	Corrective Action

---

FUEL OIL TRANSFER PIPING SYSTEM

228. Low transfer pump discharge pressure.
- STEP 1. Check for incorrect valve alignment.  
Check alignment and realign (TM 55-1905-223-10).
- STEP 2. Check for closed suction valve.  
Fully open suction valve.
- STEP 3. Check for malfunctioning pump.  
Refer to PUMPS AND MOTORS troubleshooting.
229. Fuel oil fails to flow into tanks during filling operation.
- STEP 1. Check for lack of pressure in fuel hose at fill station.
- a. Problem at supply facility.
  - b. Notify supply facility of lack of receiving pressure.
- STEP 2. Check for improper valve line up for fill operation.
- a. Deck fill connection valve (FO-3) not fully open. Open fill connection valve completely.
  - b. Transfer main or defuel main cutout valve open. Verify that the valve cross-connecting the transfer and defueling are closed.
230. Erratic receiving tank pressure and level indications during filling operations.
- STEP 1. Check for air trapped in tank.
- a. Inspect tank vent valves for obstructions or damage.
  - b. Repair or replace vent valves as necessary.
231. Erroneous tank level indications.
- STEP 1. Sound tank manually with sounding tape.  
Refer to TANK LEVEL INDICATORS troubleshooting.
- STEP 2. Check for faulty electrical circuitry.  
Refer to TANK LEVEL INDICATORS troubleshooting.
- STEP 3. Check for buildup of deposits on the tank level stem preventing free movement of the float.  
Empty the tank and clean the level stem. Refer to Tank Level Indicators troubleshooting.

Table 2-2. Troubleshooting - CONT

---

Malfunction	
Test or Inspection	
Corrective Action	

---

SEWAGE AND PLUMBING PIPING SYSTEM

232. Liquid will not flow through drain.

STEP 1. Check for clogged strainer drain or drain pipe.

a. Clean strainer.

b. Unclog drain by rodding. Remove nearest cleanout to allow mechanical cleaning of pipeline.

c. Check for malfunctioning check valve.

233. Tank cannot be dewatered, eductor suction gauge indicates a vacuum and suction valve is open.

STEP 1. Check for clogged suction tailpipe.

Clean tailpipe.

STEP 2. Check for clogged suction stop valve.

Open and clean suction stop valve and eductor suction check valve.

FOAM PROPORTIONERS (AFFF) PIPING SYSTEM

234. AFFF system fails to energize when manual control valve is opened.

STEP 1. Check for inoperative manual control valve.

Replace manual control valve.

STEP 2. Check for plugged manual control valve drain line.

Clean drain line.

STEP 3. Check for bent, crimped, or plugged piping between manual control valve and butterfly valve.

Repair or replace faulty piping (para. 2-369).

STEP 4. Check for plugged or damaged 3-way valve plug.

Repair or replace valve (para. 2-369).

STEP 5. Check for closed firemain supply to AFFF gate valve.

Open gate valve.

STEP 6. Check for plugged or damaged firemain.

Flush firemain.

STEP 7. Check for inoperative butterfly valve.

Repair or replace butterfly valve (para. 2-369).



Table 2-2. Troubleshooting - CONT

---

Malfunction	Test or Inspection	Corrective Action
-------------	--------------------	-------------------

---

FOAM PROPORTIONERS (AFFF) PIPING SYSTEM

235. AFFF system is energized but only water is discharged.
- STEP 1. Check for inoperative butterfly valve.  
Repair or replace butterfly valve (para. 2-369).
- STEP 2. Check for depleted AFFF concentrate supply.  
Replenish AFFF concentrate supply.
- STEP 3. Inadequate firemain pressure.  
Refer to BILGE/BALLAST AND FIREMAIN SYSTEM troubleshooting.
- STEP 4. Check for plugged, bent, or crimped AFFF concentrate line.  
Repair faulty line (para. 2-369).
- STEP 5. Check for closed firemain supply to AFFF gate valve.  
Open gate valve.
- STEP 6. Check for plugged or damaged firemain.  
Flush firemain.
- STEP 7. Check for inoperative butterfly valve.  
Repair or replace butterfly valve (para. 2-369).
236. No supply of AFFF concentrate.
- STEP 1. Check for empty concentrate tank.  
Replenish AFFF supply.
- STEP 2. Check for closed concentrate supply line gate valve.  
Open gate valve.

FIRE PUMP PIPING SYSTEM

237. Low discharge pressure.
- STEP 1. Check for marine growth or other foreign matter buildup on sea chest inlet.  
Back flush sea chest using ship's compressed air system.
- STEP 2. Check for closed suction valves.  
Ensure suction valves are fully open.

Table 2-2. Troubleshooting - CONT

---

Malfunction

Test or Inspection

Corrective Action

---

FIRE PUMP PIPING SYSTEM - CONT

STEP 3. Check for air bound fire pump.

Open vent valve on pump casing until pump gains positive suction.

STEP 4. Check for closed discharge pressure gauge cutout valve.

Open discharge pressure gauge cutout valve.

STEP 5. Check for leaking lines fittings, or connections.

Inspect all lines, tighten connections and fittings as necessary.

STEP 6. Check for sticking valves.

Refer to POTABLE WATER PIPING SYSTEM troubleshooting Malfunction 1, Step 6.

STEP 7. Check for leaking valves.

Refer to POTABLE WATER PIPING SYSTEM troubleshooting Malfunction 1, Step 8.

STEP 8. Check for worn or defective pump.

Refer to PUMPS AND MOTORS troubleshooting.

---

Table 2-3. Control System Normal Indications

LOCATION	PRESSURE	VISUAL
"A" NEUTRAL STAND-BY		
CONTROL STATION		
Inlet (Supply Port #2)	Yes	Lever in Neutral Position
Ahead (Port #1)	No	
Astern (Port #3)	No	
Inlet Regulator	Yes	
Out Regulator	No	
GEAR-MATE PANEL		
Ports 1-2-3-4-5-6	No	Both Red Pins at Bottom of Valves Up or Retracted
THROTTLE INTERLOCK		
(In) Line	No	No Visible Check
(Out) Line	No	
GEAR ACTUATOR		
Ahead Port	No	Shift Lever 1 or Rod in Mid or Neutral
Astern Port	No	
GOVERNOR ACTUATOR		
Supply (In) Line	No	Lever In Retracted Position
"B" AHEAD THROTTLE (INITIAL)		
CONTROL STATION		
Inlet (Supply Port #2)	Yes	Lever at Least 20' in the Ahead Position from Center
Ahead (Port #1)	Yes	
Astern (Port #3)	No	
Inlet Regulator	Yes	
Out Regulator	Yes	
GEAR-MATE PANEL		
Ports		
1	Yes	Red Pin on Valve #21 UP or Retracted
2	No	
3	No	
4	Yes	Red Pin on Valve #22 Down or Extended
5	Yes	
6	No	
THROTTLE INTERLOCK		
(In) Line	Yes	No Visible Check
(Out) Line	No	
(Air) Line	Yes	
(Oil) Line	No	

Table 2-3. Control System Normal Indications - Cont

LOCATION	PRESSURE	VISUAL
"B" AHEAD THROTTLE (INITIAL) (CONT'D)		
GEAR ACTUATOR Ahead Port	Yes	Shift Lever In Actuated or Ahead Position
Astern Port	No	
GOVERNOR ACTUATOR Supply (In) Line	No	Lever In Retracted Position
"C" AHEAD THROTTLE (AFTER DELAY)		
CONTROL STATION Inlet (Supply Port #2)	Yes	Lever at Least 20' in the Ahead Position from Center
Ahead (Port #1)	Yes	
Astern (Port #3)	No	
Inlet Regulator	Yes	
Out Regulator	Yes	
GEAR-MATE PANEL Ports		
1	Yes	Red Pin on Valve #21 Up or Retracted
2	No	
3	No	Red Pin on Valve #22 Down or Extended
4	Yes	
5	Yes	
6	No	
THROTTLE INTERLOCK (In) Line	Yes	No Visual Check
(Out)	Yes	
(Air)	Yes	
(Oil)	Yes	
GEAR ACTUATOR Ahead Port	Yes	Shift Lever In Actuated or Ahead Position
Astern Port	No	
GOVERNOR ACTUATOR Supply (In) Line	Yes	Moved to Control Station Setting
"D" NEUTRAL - ASTERN DELAY		
CONTROL STATION Inlet (Supply Port #2)	Yes	Lever In Neutral Position
Ahead (Port #1)	No	
Astern (Port #3)	No	
Inlet Regulator	Yes	
Out Regulator		

Table 2-3. Control Systems Normal Indications - Cont

LOCATION	PRESSURE	VISUAL
"D" NEUTRAL - ASTERN DELAY - CONT		
GEAR-MATE PANEL		
Ports		
1	No	Red Pin on Valve #21 Up or Retracted
2	No	
3	No	
4	No	Red Pin on Valve #22 Down or Extended
5	No	
6	No	
THROTTLE INTERLOCK		
(In) Line	No	No Visual Check
(Out) Line	No	
(Air) Line	No	
(Oil) Line	No	
GEAR ACTUATOR		
Ahead Port	No	Shift Lever Rod at Mid or Neutral
Astern Port	No	
GOVERNOR ACTUATOR		
Supply (In) Line	No	Lever in Retracted Position
"E" ASTERN THROTTLE (INITIAL)		
CONTROL STATION		
Inlet (Supply Port #2)	Yes	Lever At Least 20' in the Astern Position From Center
Ahead (Port #1)	No	
Astern (Port #3)	Yes	
Inlet Regulator	Yes	
Out Regulator	Yes	
GEAR-MATE PANEL		
Ports		
1	No	Red Pin On Valve #21 Down or Extended
2	Yes	
3	Yes	
4	No	Red Pin On Valve Up or Retracted
5	No	
6	Yes	
THROTTLE INTERLOCK		
(In) Line	Yes	No Visual Check
(Out) Line	No	
(Air) Line	Yes	
(Oil) Line	No	

Table 2-3. Control Systems Normal Indications - Cont

LOCATION	PRESSURE	VISUAL
"E" ASTERN THROTTLE (INITIAL) - CONT		
GEAR ACTUATOR		
Ahead Port	No	Shift Lever Actuated or Astern Position
Astern Port	Yes	
GOVERNOR ACTUATOR		
Supply (In) Line	No	Lever In Retracted Position
"F" ASTERN THROTTLE (AFTER DELAY)		
CONTROL STATION		
Inlet (Supply Port #2)	Yes	Lever at Least 20' in the Astern Position from Center
Ahead (Port #1)	No	
Astern (Port #3)	Yes	
Inlet Regulator	Yes	
Out Regulator	Yes	
GEAR-RATE PANEL		
Ports		
1	No	Red Pin on Valve #21 Down or Extended
2	Yes	
3	Yes	
4	No	Red Pin on Valve #22 Up or Retracted
5	No	
6	Yes	
THROTTLE INTERLOCK		
(In) Line	Yes	No Visual Check
(Out) Line	Yes	
(Air) Line	Yes	
(Oil) Line	Yes	
GEAR ACTUATOR		
Ahead Port	No	Shift Lever in Actuated or Astern Position
Astern Port	Yes	
GOVERNOR ACTUATOR		
Supply (In) Line	Yes	Moved to Control Station Setting

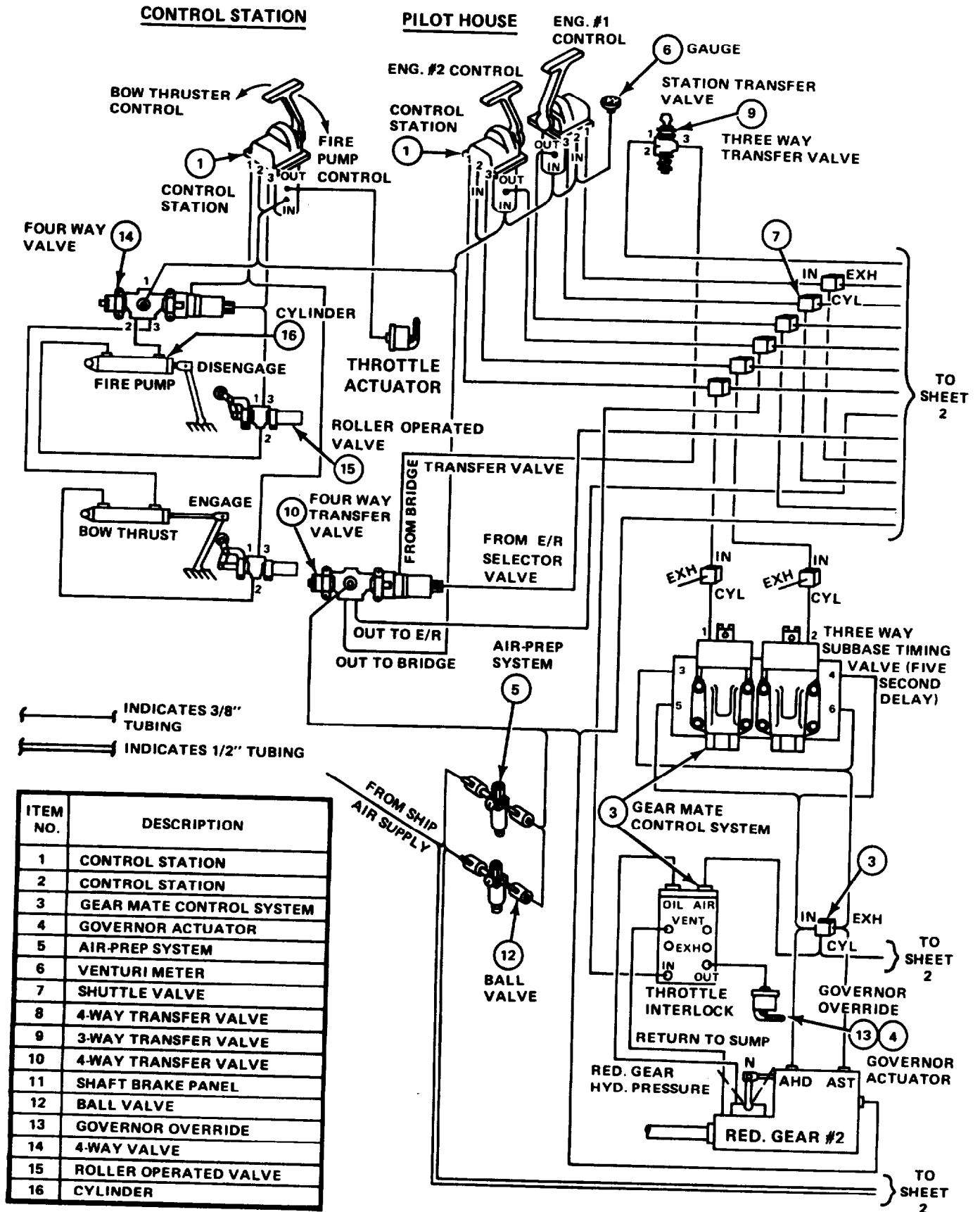


FIGURE 2-1 Control System (Sheet 1 of 2).

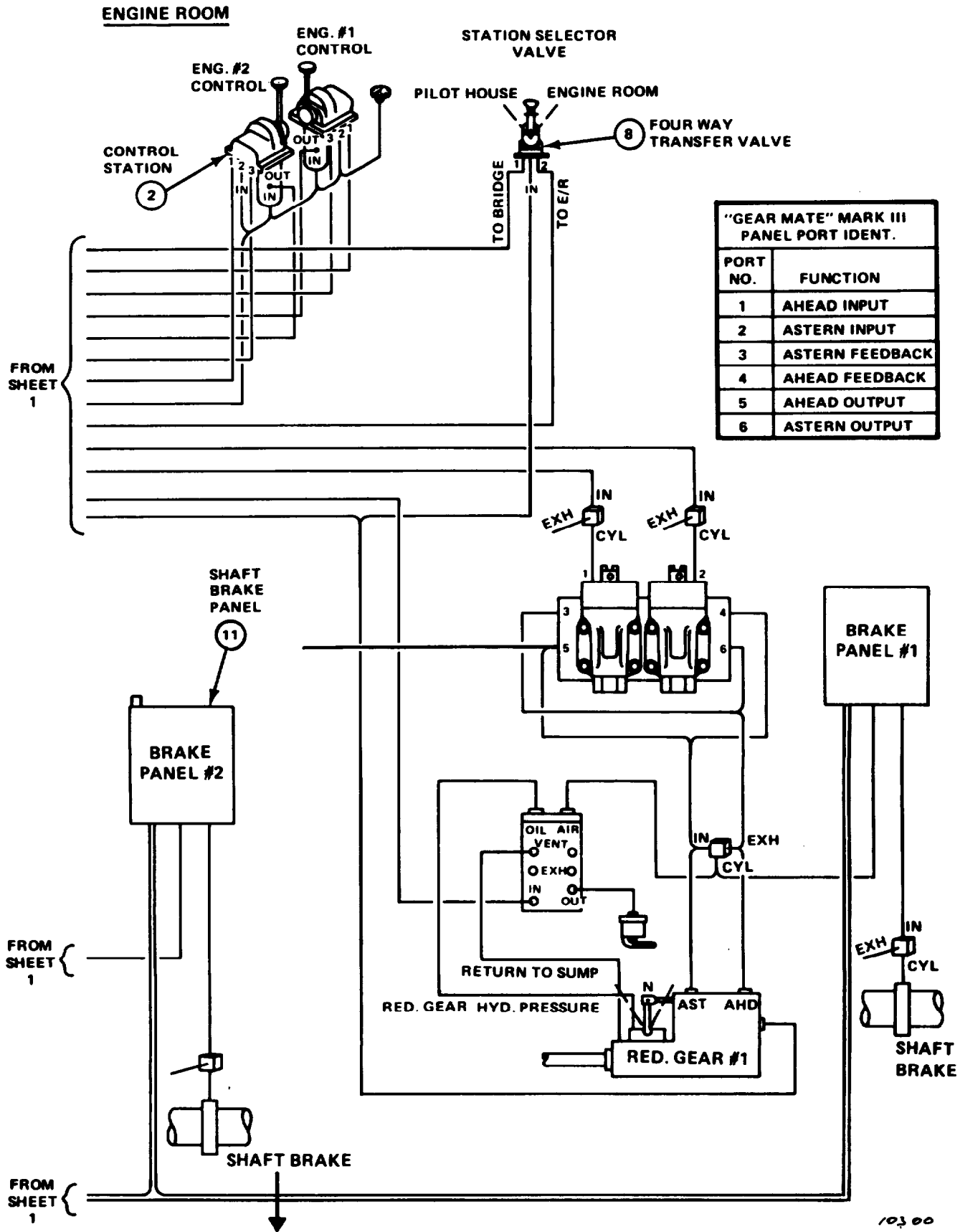


FIGURE 2-1. Control System (Sheet 2 of 2).



## Section Q. UNIT MAINTENANCE PROCEDURES

2-13. Detailed Procedures. Information to perform unit maintenance tasks, in accordance with the Maintenance Allocation Charts (MACs), is provided. The procedures for each separate MAC begin with a boxed heading showing:

MAINTENANCE OF. . . .
-----------------------

MAINTENANCE OF FURNITURE AND FIXTURES
---------------------------------------

---

## 2-14. Replace/Repair Furniture and Fixtures Group. (FIGURE 2-2, Sheets 1 - 14)

---

This task covers: a. Removal, b. Repair, c. Replacement.

---

### INITIAL SETUP

#### Tools

Tool kit, general mechanic's,  
5180-00-699-5273

---

### REMOVAL

Remove items 1 - 49 by removing common attaching hardware.

<u>Item</u>	<u>Sheet</u>	<u>Nomenclature</u>	<u>Item</u>	<u>Sheet</u>	<u>Nomenclature</u>
1	1	Shipboard berth	25	6	Ready service
2	1	Shipboard berth			ammunition locker
3	1	Shipboard berth	26	7	Ammunition locker
4	1	Hospital berth	27	7	Small arms locker
5	2	Bulletin board	28	7	Machine gun locker
6	2	Rudder course board	29	8	Full length mirror
7	2	Status board	30	8	Life preserver rack
8	2	Bookcase	31	8	Refrigerator
9	3	Double bookrack	32	8	Safe (Type 1433C)
10	3	Coffee cabinet	33	9	Safe (Type 7)
11	3	Key cabinet	34	9	Server
12	3	Chest of drawers	35	10	Sideboard
13	3	Writing insert (for chest of drawers)			(with refrigerator)
14	4	Entertainment console	36	10	Chart table
15	4	Log desk			(with chronometer case)
16	4	Flat-top desk	37	11	Mess table
17	4	Hinged damage control leaf unit	38	11	Night table
			39	11	Night table
			40	11	File cabinet
18	5	Locker	41	12	Wardrobe
19	5	Locker	42	12	Workbench
20	5	Bulkhead mounted locker	43	12	Deck pad
21	5	Wardrobe locker	44	13	Locker
22	6	Portable flag bag locker	45	13	Damage control locker
			46	13	Bulletin board
23	6	Medicine locker	47	14	Grenade locker
24	6	Pyrotechnics locker	48	14	Grenade fuse locker
			49	14	Single bookrack

REPAIR

Repair is by replacement of items 1 through 49.

REPLACEMENT

Replacement of items 1 through 49 is by inserting and securing common attaching hardware.

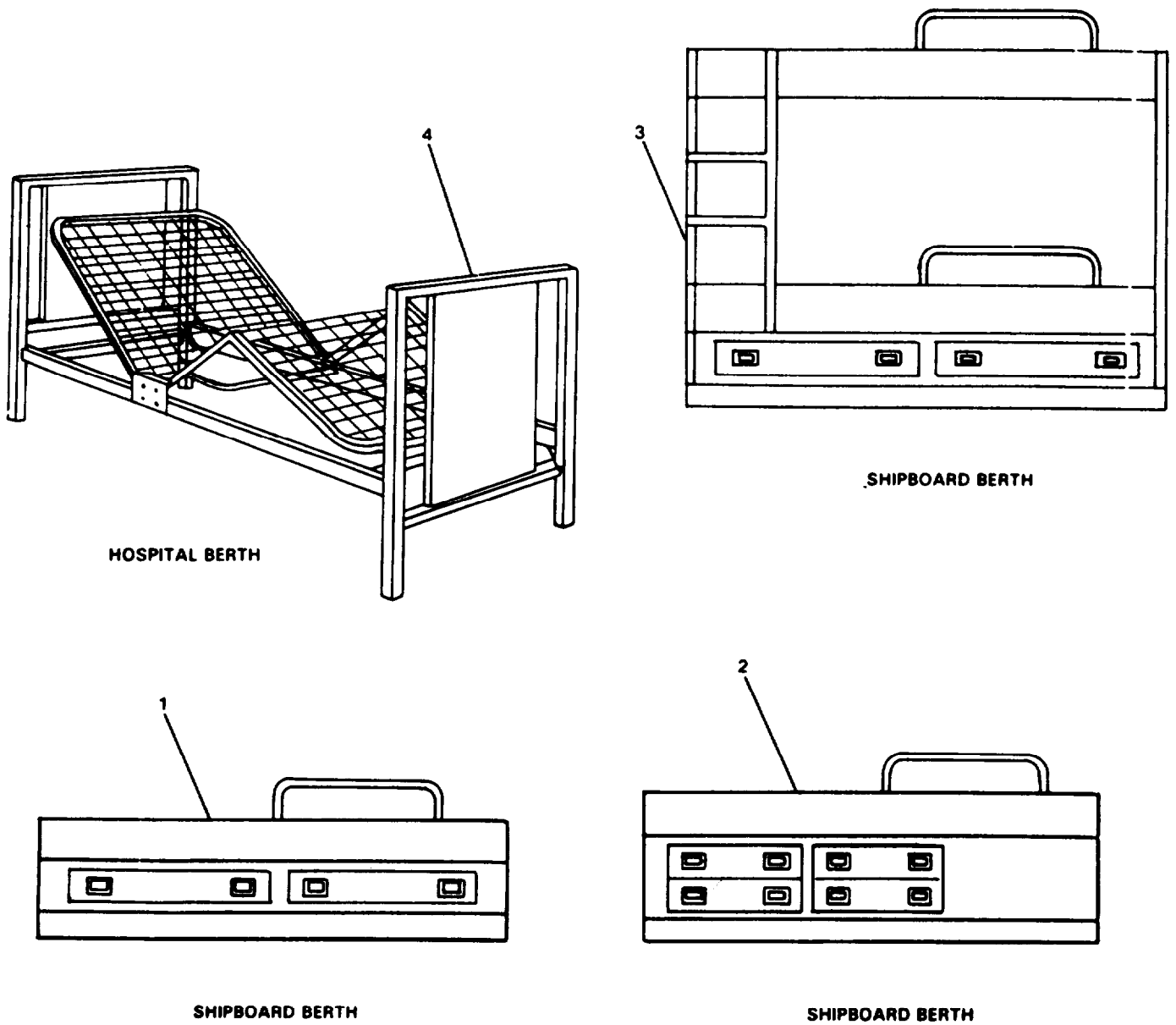


FIGURE 2-2. Furniture and Fixtures (Sheet 1 of 14).

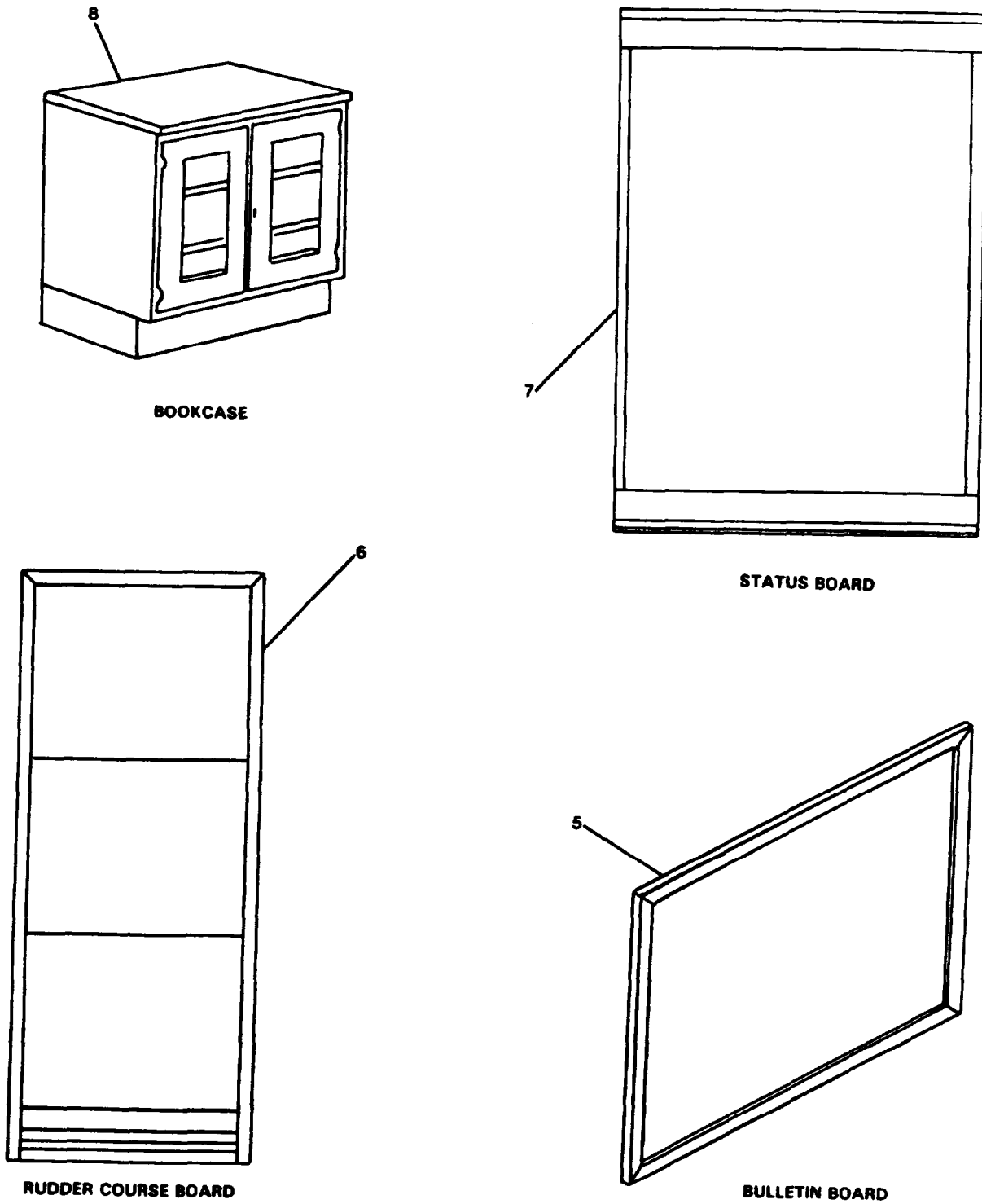


FIGURE 2-2. Furniture and Fixtures (Sheet 2 of 14).

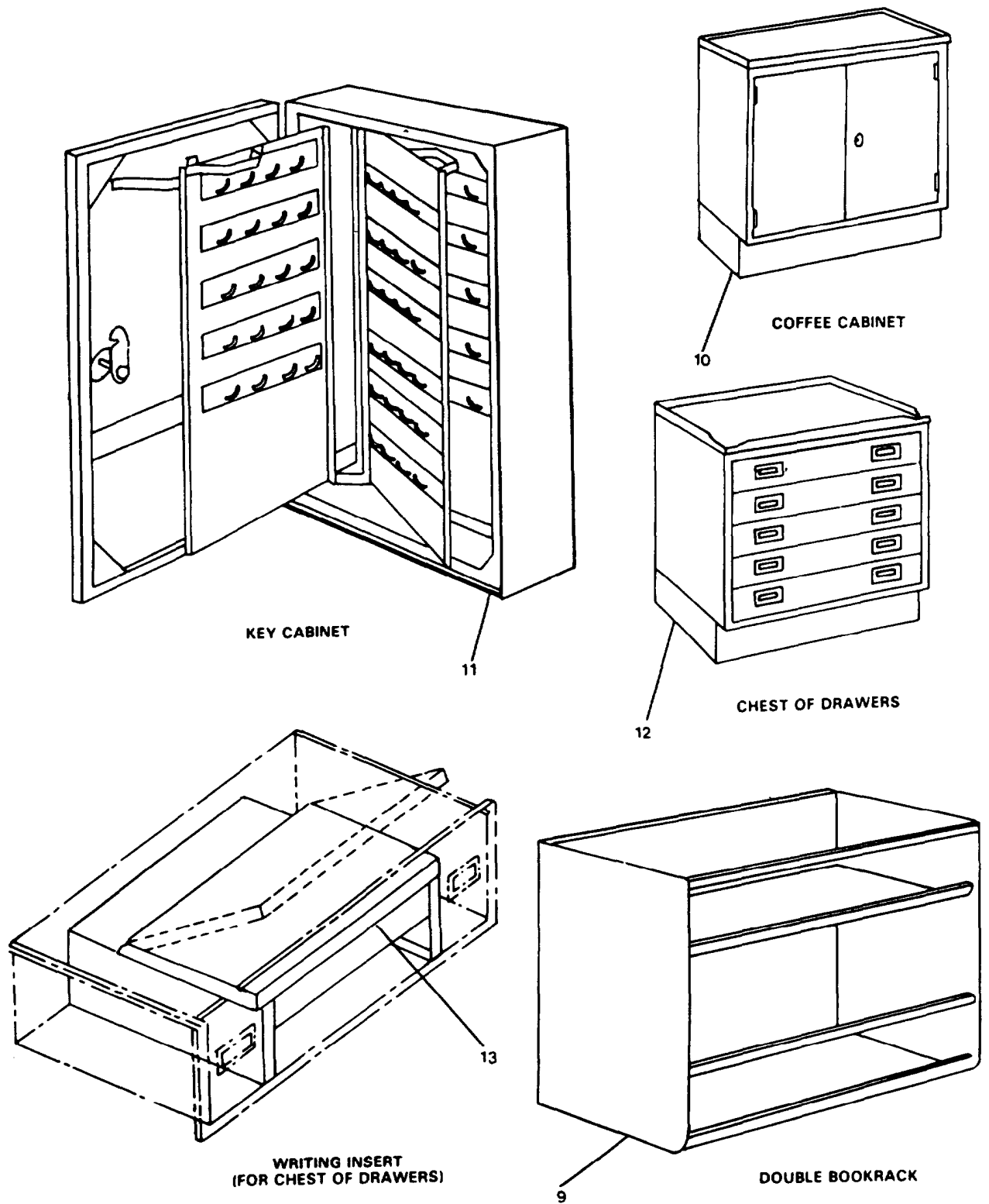
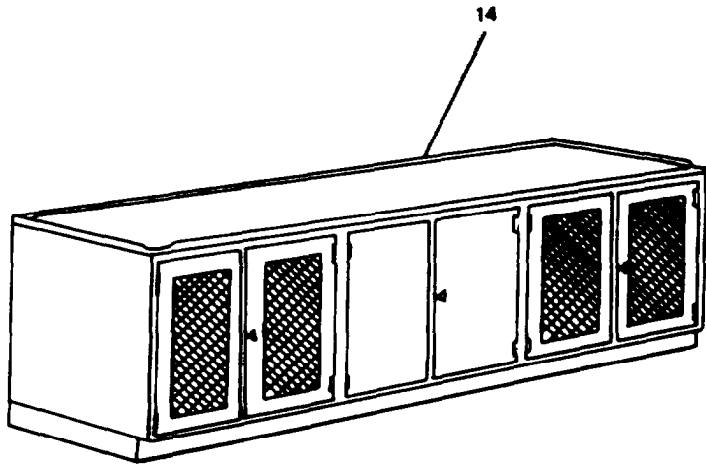
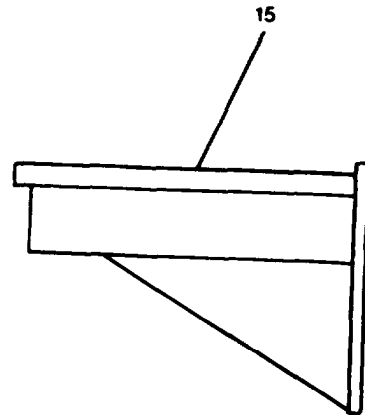


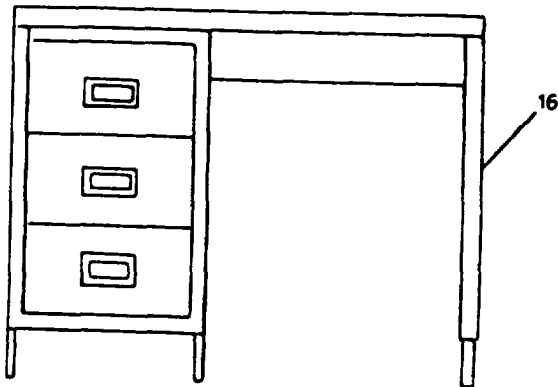
FIGURE 2-2. Furniture and Fixtures (Sheet 3 of 14).



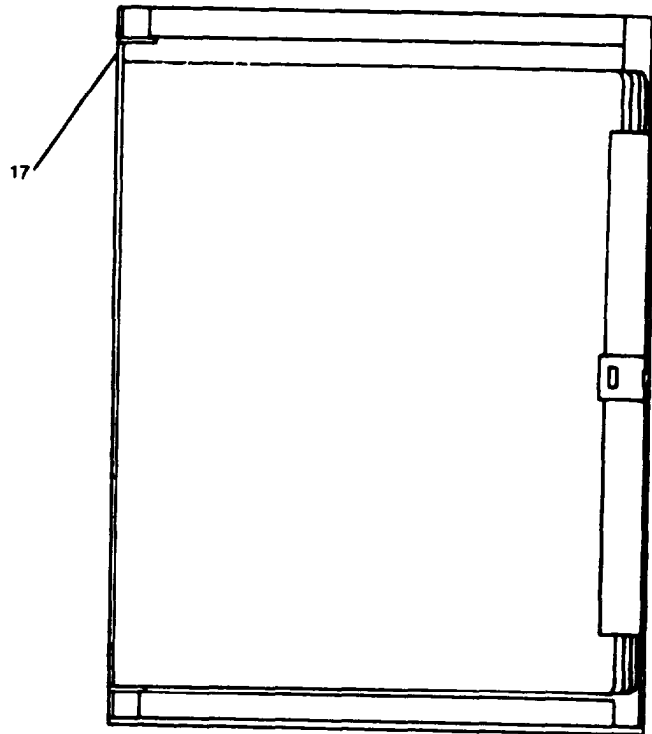
ENTERTAINMENT CONSOLE



LOG DESK

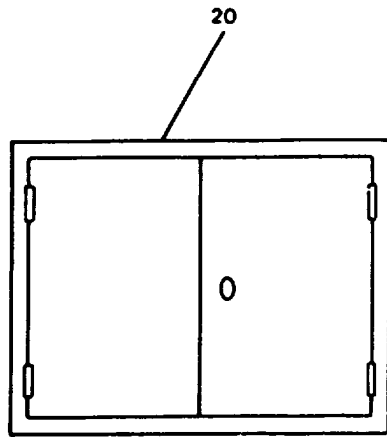


FLAT-TOP DESK

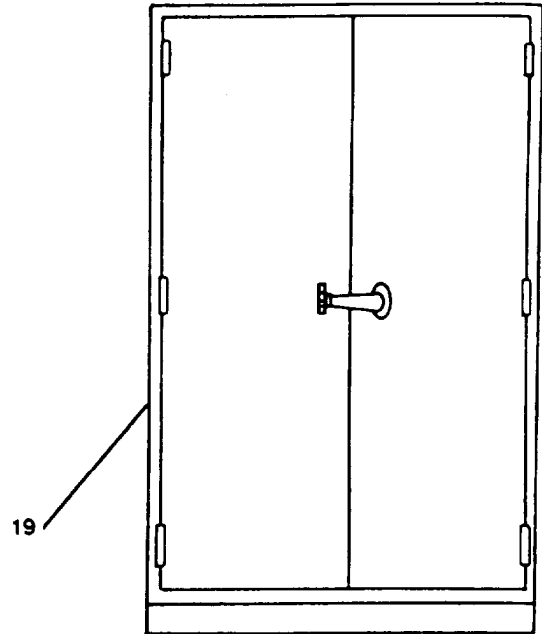


HINGED DAMAGE CONTROL LEAF UNIT

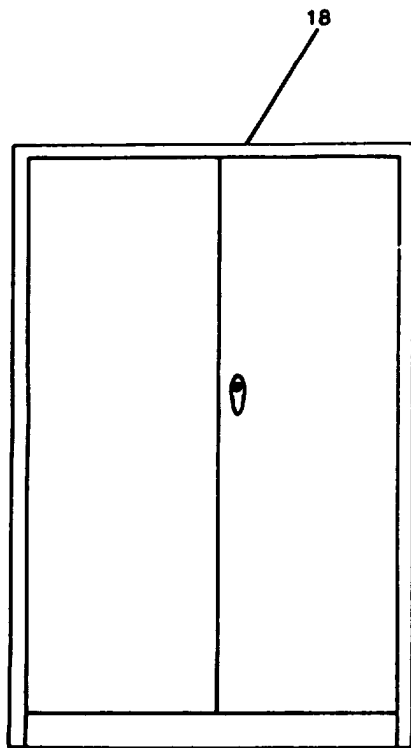
FIGURE 2-2. Furniture and Fixtures (Sheet 4 of 14).



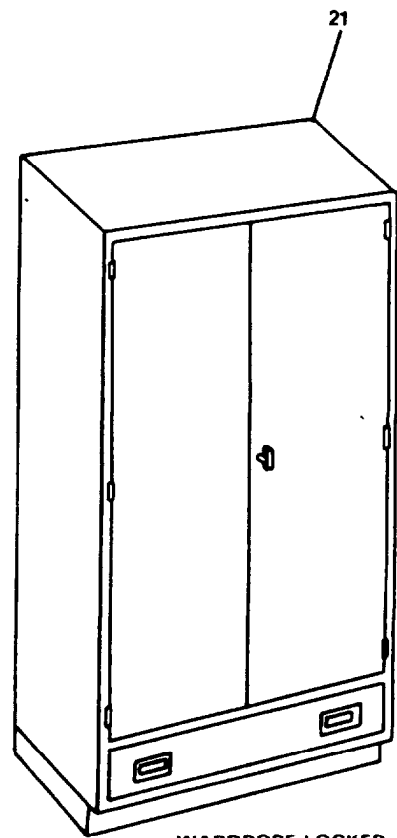
**BULKHEAD MOUNTED LOCKER**



**LOCKER**

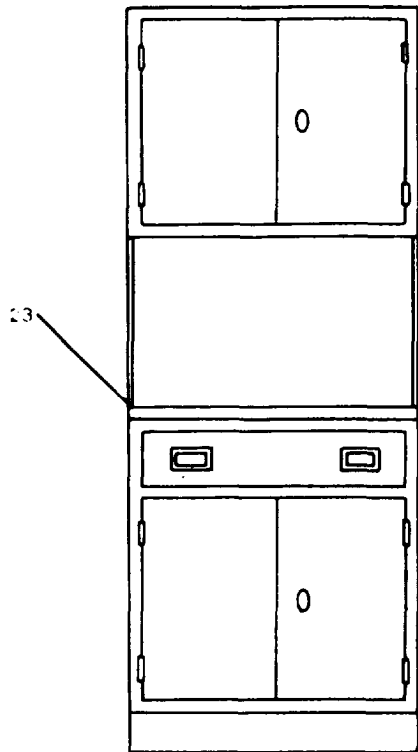


**LOCKER**

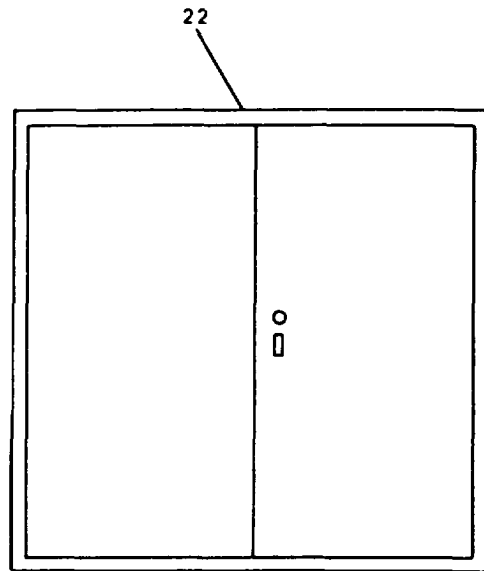


**WARDROBE LOCKER**

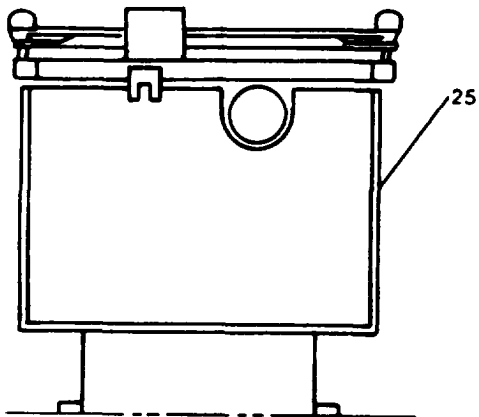
FIGURE 2-2. Furniture and Fixtures (Sheet 5 of 14).



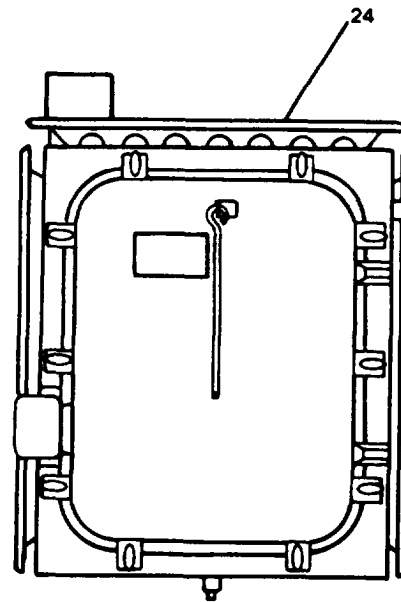
**MEDICINE LOCKER**



**PORTABLE FLAG BAG LOCKER**



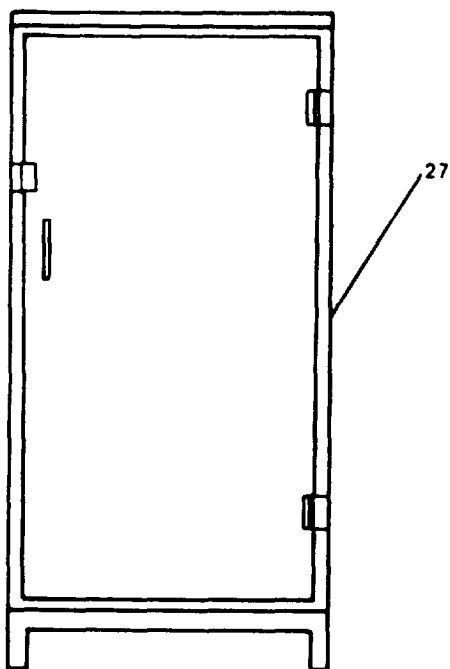
**READY SERVICE AMMUNITION LOCKER**



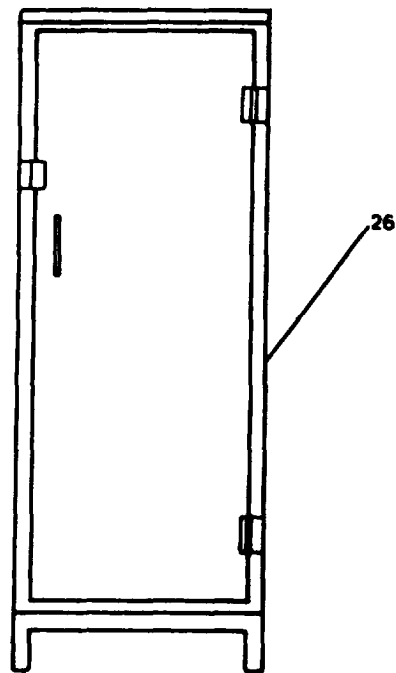
**PYROTECHNICS LOCKER**

**FIGURE 2-2. Furniture and Fixtures (Sheet 6 of 14).**

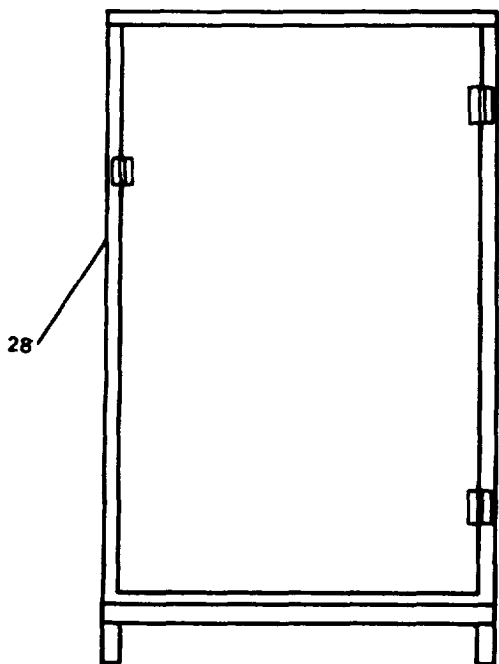




**SMALL ARMS LOCKER**

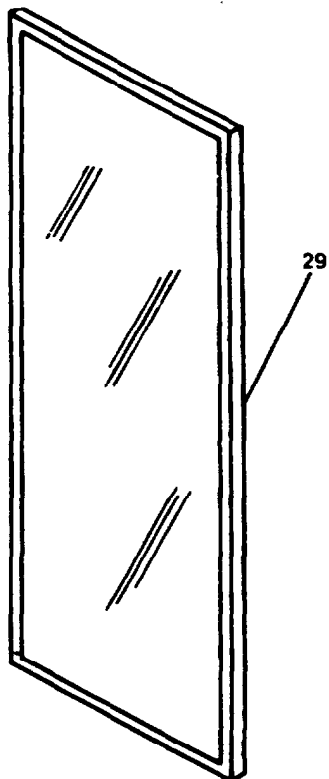


**AMMUNITION LOCKER**

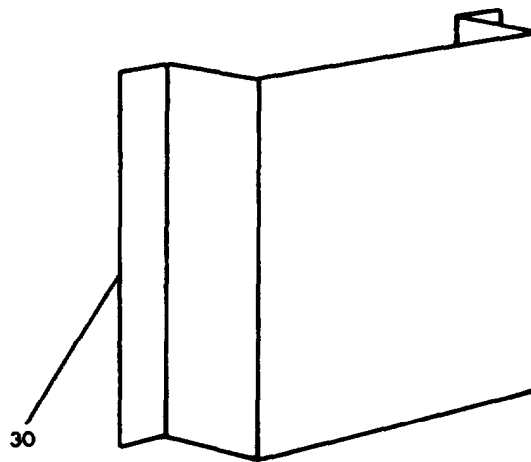


**MACHINE GUN LOCKER**

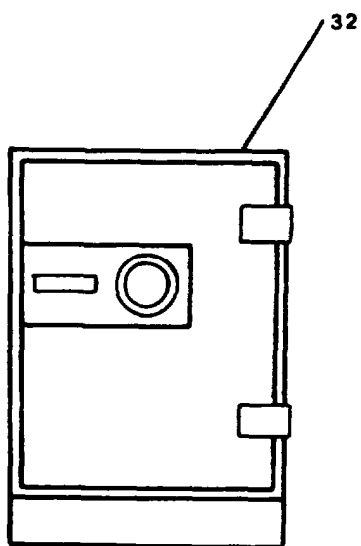
**FIGURE 2-2. Furniture and Fixtures (Sheet 7 of 14).**



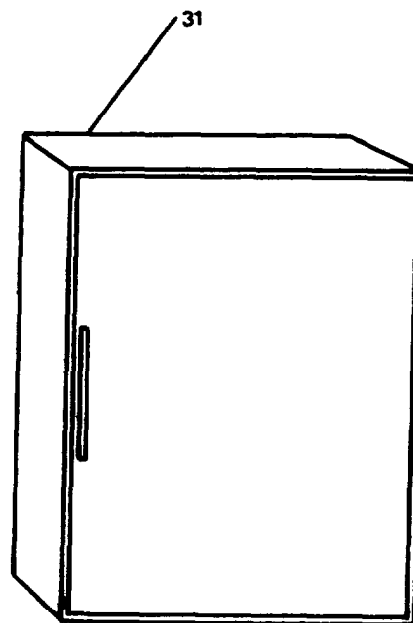
**FULL LENGTH MIRROR**



**LIFE PRESERVER RACK**

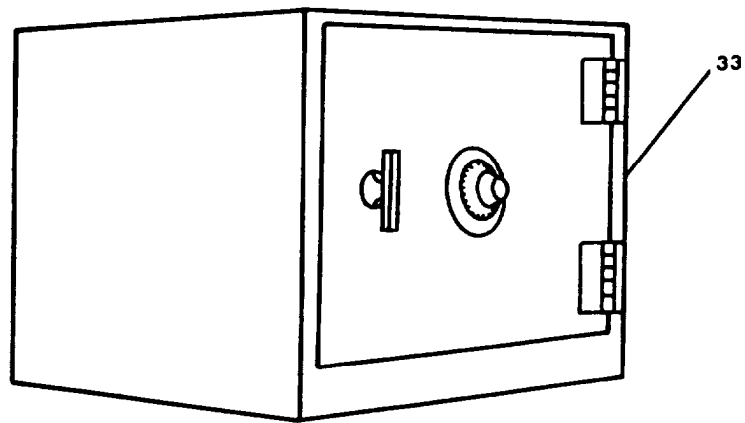


**SAFE (TYPE 1433C)**

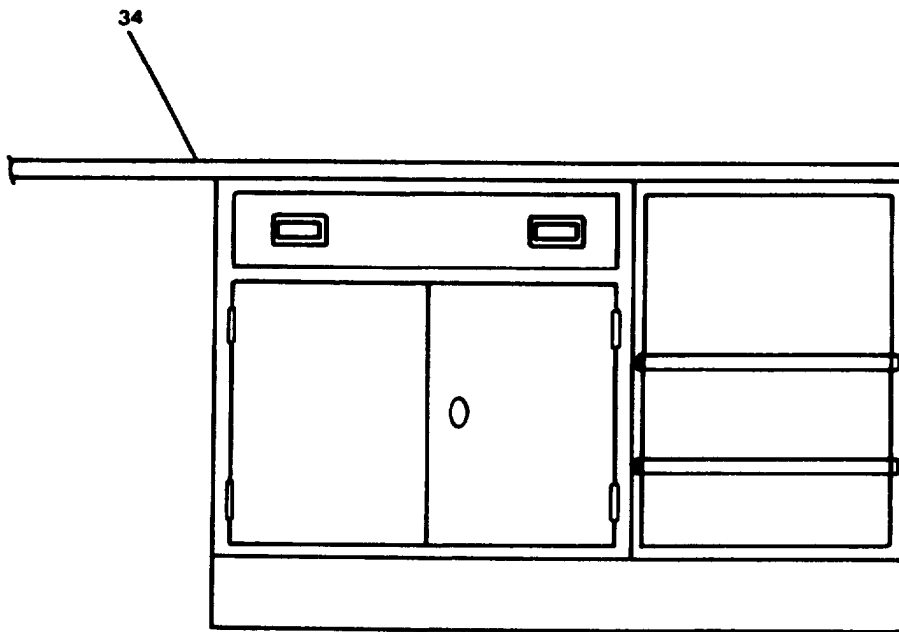


**REFRIGERATOR**

**FIGURE 2-2. Furniture and Fixtures (Sheet 8 of 14).**

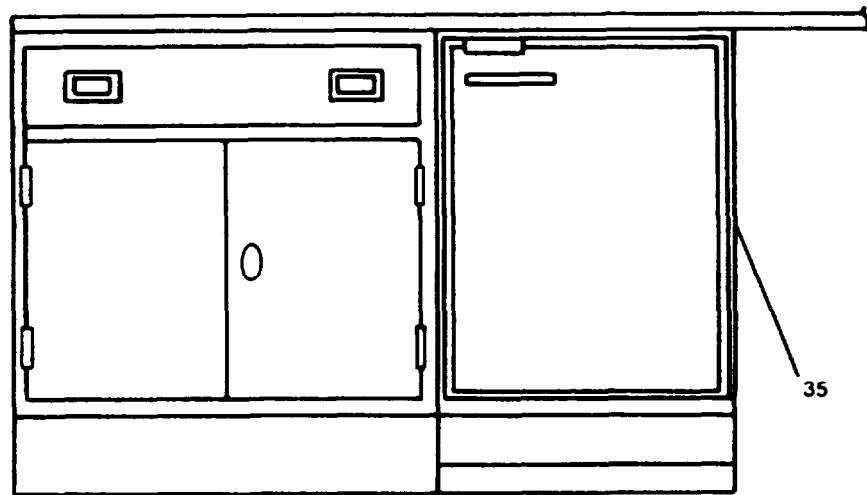


**SAFE (TYPE 7)**

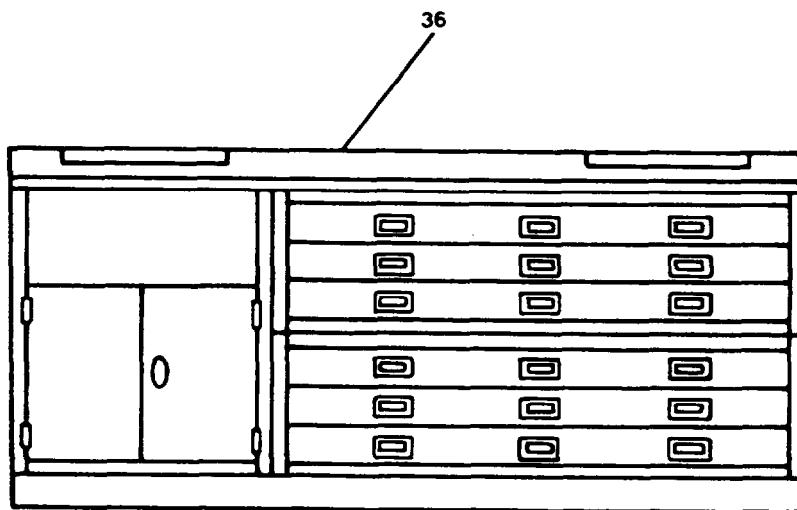


**SERVER**

FIGURE 2-2. Furniture and Fixtures (Sheet 9 of 14).

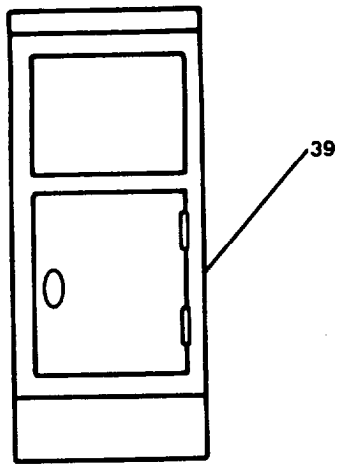


**SIDEBOARD WITH REFRIGERATOR**

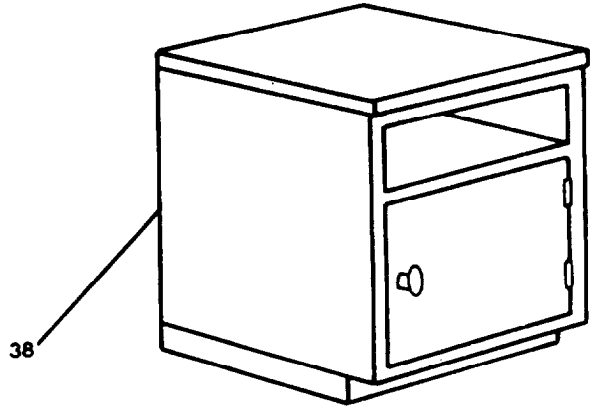


**CHART TABLE WITH CHRONOMETER CASE**

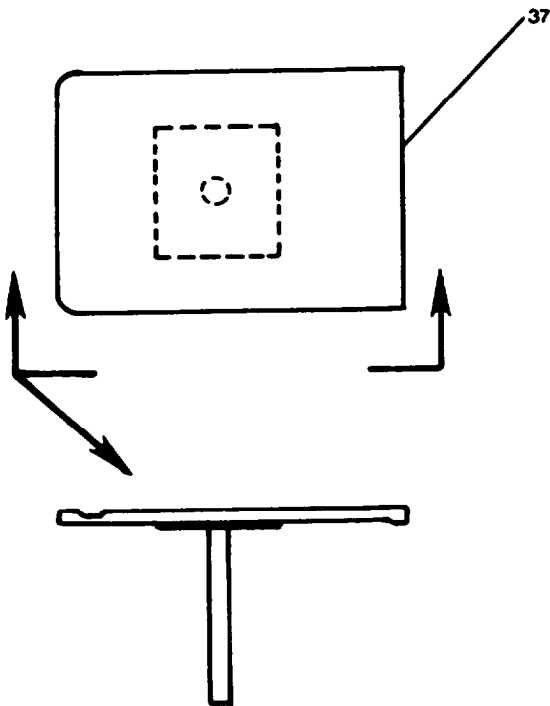
FIGURE 2-2. Furniture and Fixtures (Sheet 10 of 14).



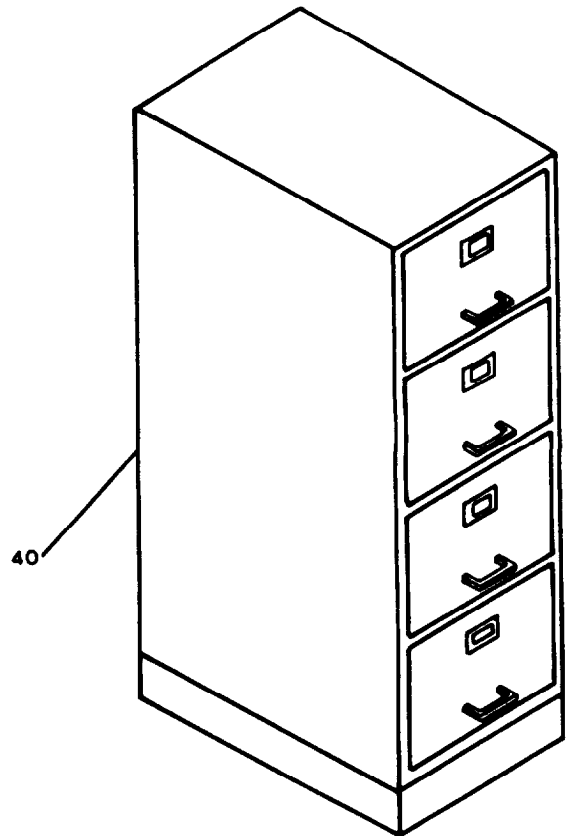
**NIGHT TABLE**



**NIGHT TABLE**

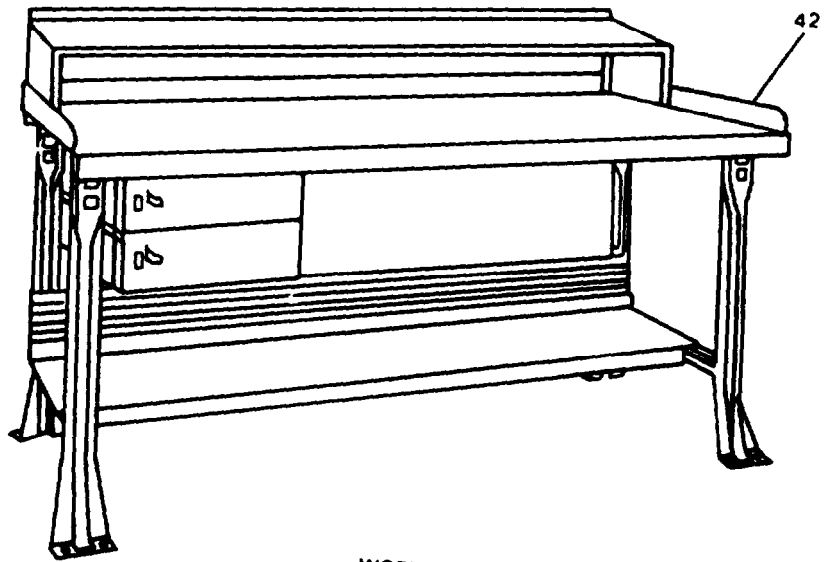


**MESS TABLE**

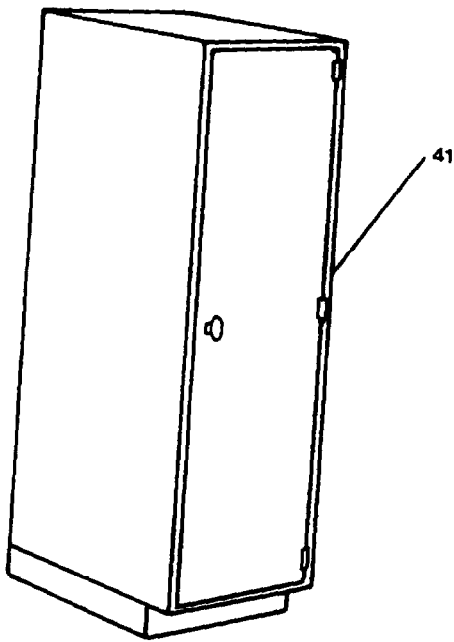


**FILE CABINET**

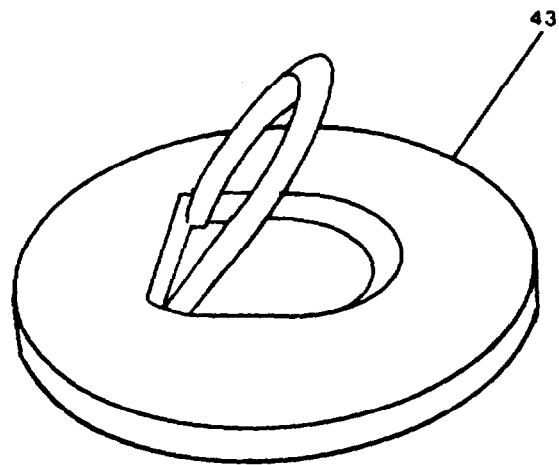
FIGURE 2-2. Furniture and Fixtures (Sheet 11 of 14).



WORKBENCH

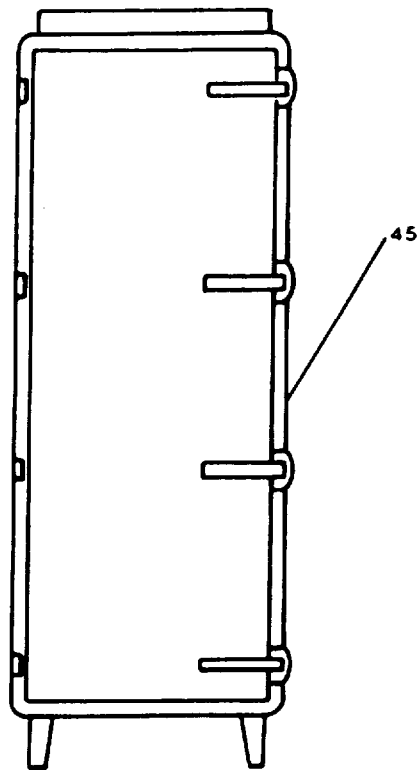


WARDROBE

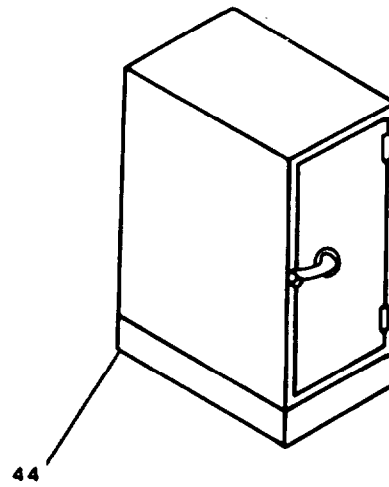


DECK PAD

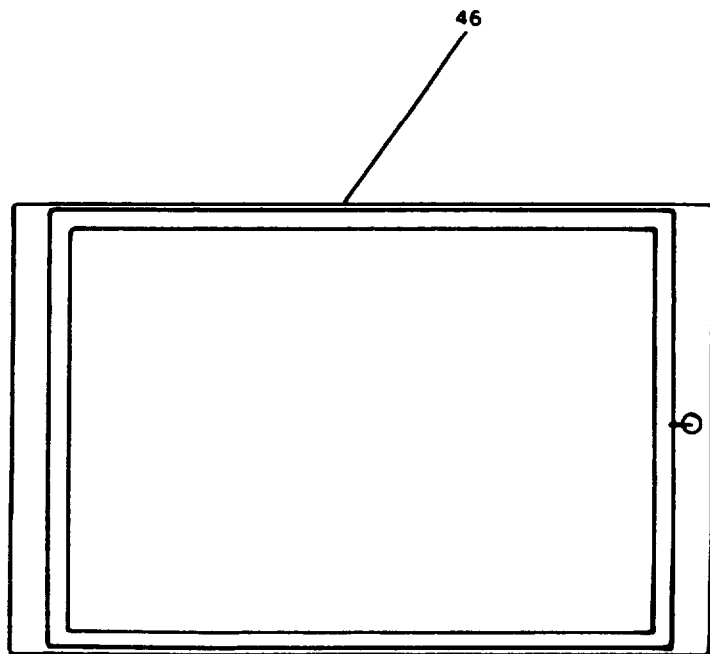
FIGURE 2-2. Furniture and Fixtures (Sheet 12 of 14)



**DAMAGE CONTROL LOCKER**



**LOCKER**



**BULLETIN BOARD**

FIGURE 2-2. Furniture and Fixtures (Sheet 13 of 14).

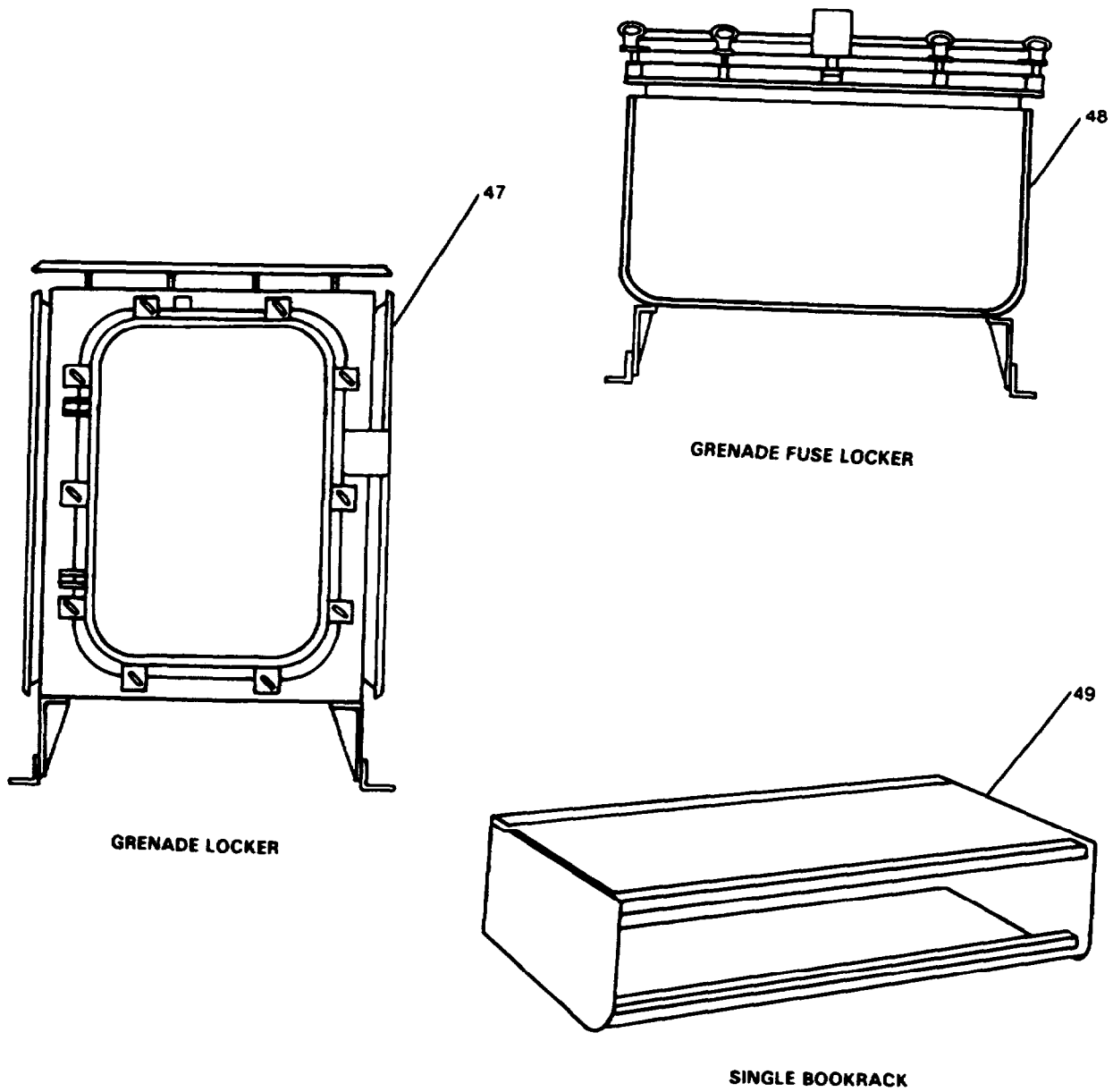


FIGURE 2-2. Furniture and Fixtures (Sheet 14 of 14).



MAINTENANCE OF ENTERTAINMENT SYSTEM
-------------------------------------

---

## 2-15. Replace/Repair Entertainment System (FIGURE 2-3)

---

This task covers: a. Removal, b. Repair, c. Replacement.

---

### INITIAL SETUP

#### Tools

Tool kit, general mechanic's,  
5180-00-699-5273

#### Equipment Condition

Color television and video cassette  
recorder turned off.

#### Materials/Parts

Color television P/N FMR490D  
Video cassette recorder P/N 53293  
Video amplifier P/N MODEL 4320

---

### REMOVAL

- a. Remove video cassette recorder (VCR) plug (2) from wall outlet.
- b. Remove color television (TV) plug (5) from wall outlet.
- c. Remove video amplifier plug (6) from wall outlet.
- d. Disconnect cable (3) from TV jack (12) on rear of VCR (1).
- e. Disconnect cable (3) from input jack (4) on rear of TV (9).
- f. Disconnect cable (10) from RF IN jack (11) on rear of VCR (1).
- g. Disconnect cable (10) from video amplifier (8).
- h. Disconnect antenna cable (7) from video amplifier (8).

### REPAIR

Repair of the VCR, TV, and video amplifier is by replacement.

### REPLACEMENT

- a. Connect cable (7) to video amplifier (8).
- b. Connect cable (10) to video amplifier (8).

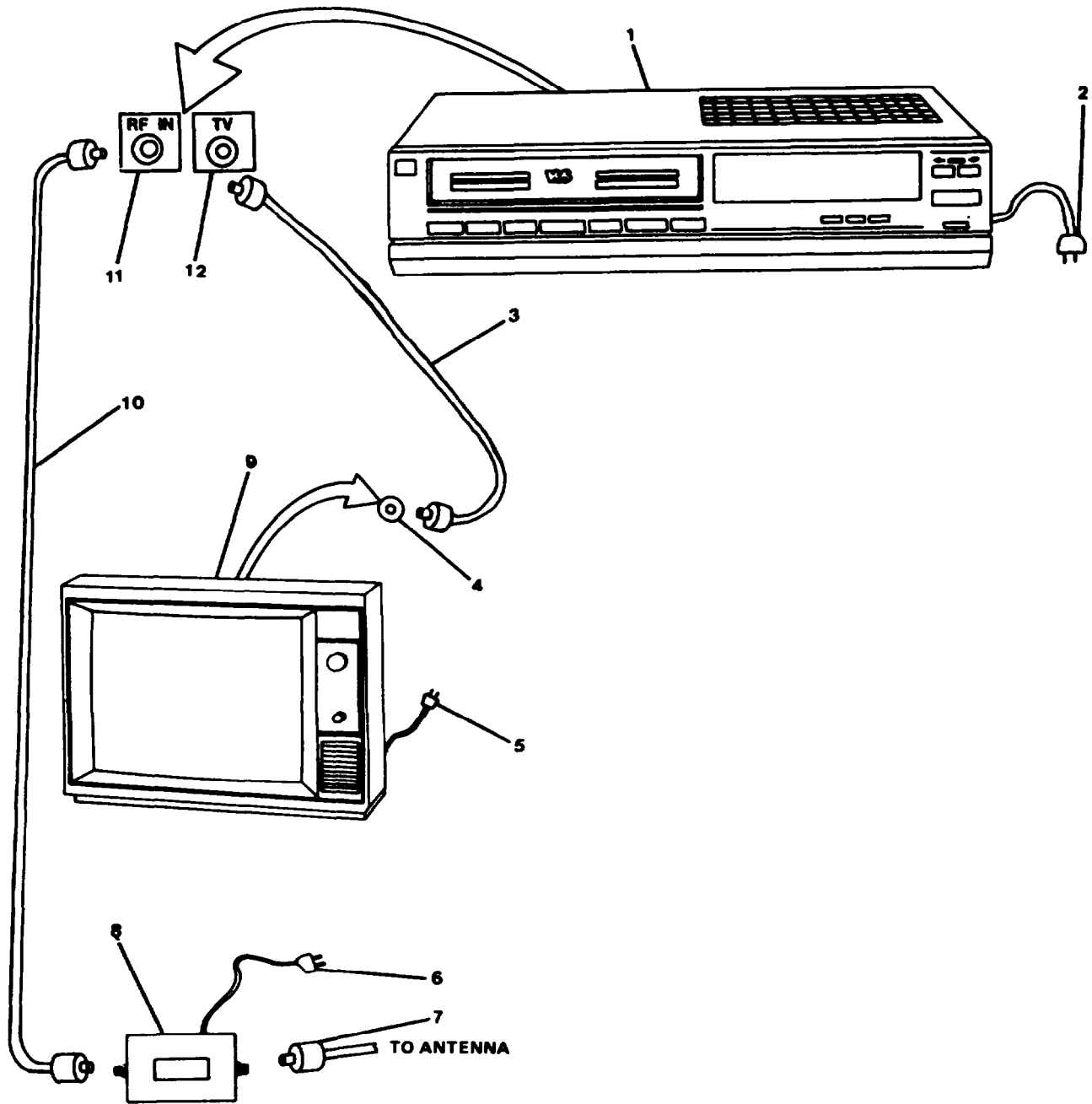


FIGURE 2-3. Entertainment System.

- c. Connect cable (10) to RF IN jack (11) on rear of VCR (1).
- d. Connect cable (3) to input jack (4) on rear of TV (9).
- e. Connect cable (3) to TV jack (12) on rear of VCR (1).
- f. Install video amplifier plug (6) in wall outlet.
- g. Install TV plug (5) in wall outlet.
- h. Install VCR plug (2) in wall outlet.

2-16. Repair Omnidirectional Antenna. (FIGURE 2-4)

---

This task covers: a. Disassembly, b. Repair, c. Assembly.

---

INITIAL SETUP

Tools

Equipment Condition

Tool kit, general mechanic's,  
5180-00-699-5273  
Tool kit, electrician's,  
5180-00-391-1087  
Ohmmeter, 6625-00-141-3558

Shut down - TM 55-1905-223-10.

Materials/Parts

Omnidirectional antenna  
P/N MR-106-36D  
Coaxial connector P/N 50903  
Neoprene weathershield  
P/N 600009-39E-8  
Coaxial cable P/N RG-11A/U  
Foam filled dome P/N 600009-39E-1  
Spacing insulator P/N 50924  
Antenna element P/N 50921  
Antenna element P/N 50922  
Crocus cloth, Item 2, Appendix C

---

DISASSEMBLY

- a. Pull back neoprene weathershield (9) and disconnect antenna lead-in coaxial male/female (8) at bottom on antenna.
- b. While carefully supporting antenna, remove two clamps (11) which secure antenna to supporting -pipe.
- c. Remove antenna and carefully place on deck.

REPAIR

- a. Carefully inspect the antenna elements (3) and (13) and wiring connections for corrosion and breaks. Clean off corrosion using a crocus cloth.

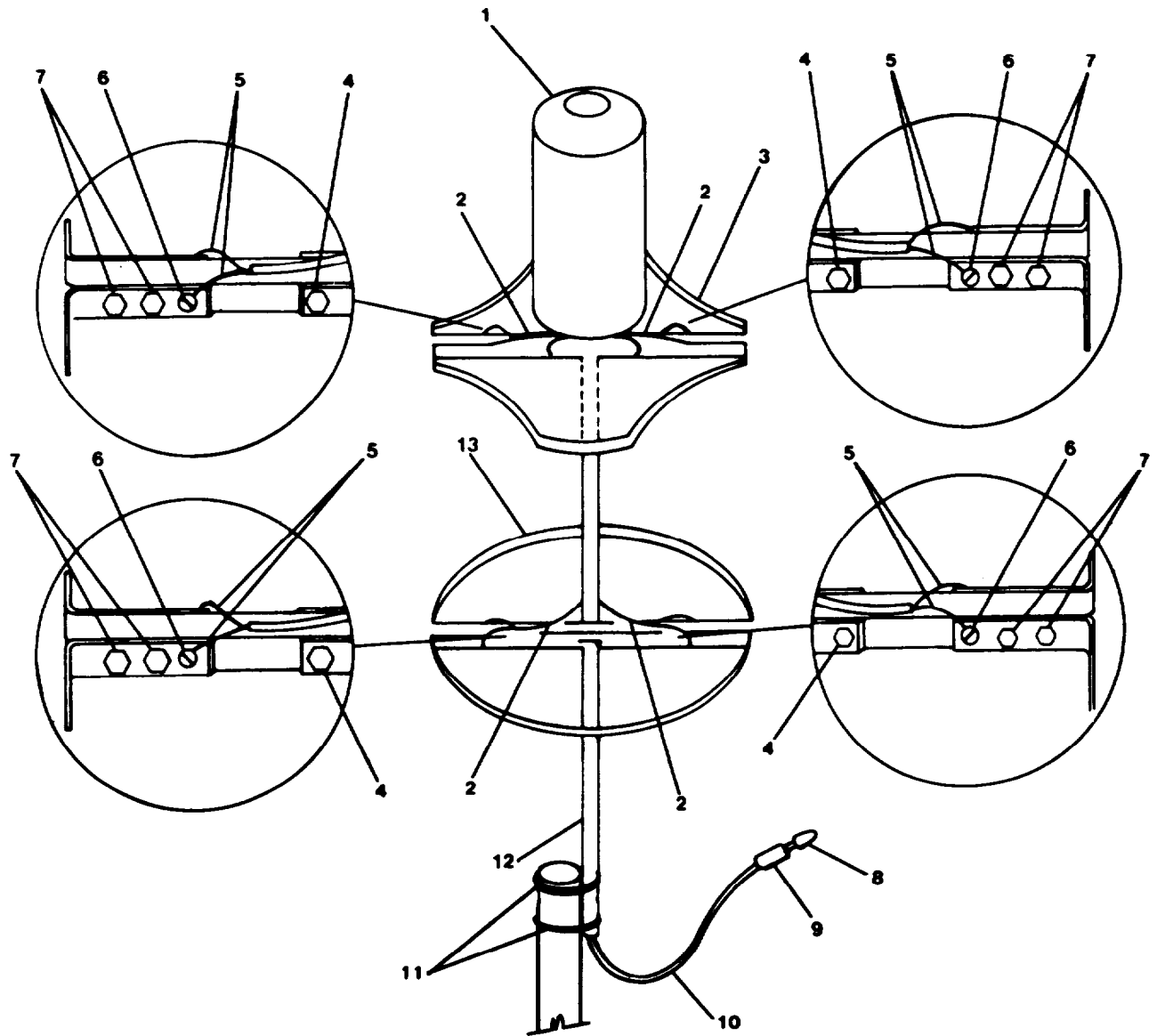


FIGURE 2-4. Omnidirectional TV Antenna.

- b. Remove and replace any broken parts.
- c. Use an ohmmeter to check the coaxial cable (10) and the antenna cables (5).

NOTE

Carefully note which antenna cables are black and which antenna cables have a red stripe for reattaching the terminal lugs.

- d. Disconnect antenna cables (5) by removing the plain nuts and lock washer (6).

NOTE

Carefully note which nuts and bolts are red and which are black for reassembly of the antenna elements.

- e. Remove two bottom antenna elements (13) by removing two nylon plain hexagon nuts and two nylon machine bolts (7) from each side of the antenna elements.
- f. Remove two top antenna elements (3) by removing two nylon plain hexagon nuts and two nylon machine bolts (7) from each side of the antenna elements.
- g. Remove the foam filled dome (1) by unscrewing from the top of the antenna mast (12).
- h. Remove coaxial cable (10) from the antenna mast.
- i. Remove the male coaxial connector (8) from the coaxial cable (10) by unsoldering the central conductor and shield.
- j. Remove the neoprene weathershield (9) from the coaxial cable (10).
- k. Remove the two bottom and two top spacing insulators (2) by removing the plain hexagon nuts lockwashers and machine screws (4).

ASSEMBLY

- a. Install the two top and two bottom spacing insulators (2) by replacing the machine screws, lock washers, and plain hexagon nuts (4).
- b. Slide the neoprene weathershield (9) onto the coaxial cable (10).
- c. Solder the central conductor and shield on the coaxial cable (10) to the male coaxial connector (8).
- d. Install the coaxial cable (10) into the antenna mast.
- e. Screw the foam filled dome (1) onto the top of the antenna mast (12).
- f. Install the two top antenna elements (3) by installing two nylon machine bolts through each side of the antenna elements and securing with two nylon plain hexagon nuts (7) on each side of the antenna elements.

- g. Install the two bottom antenna elements (13) by installing two nylon machine bolts through each side of the antenna elements and securing with two nylon plain hexagon nuts (7) on each side of the antenna elements.
- h. Holding antenna vertical, attach to supporting pipe with two clamps (11).
- i. Set clamps as far apart as possible, but not less than eight inches apart.
- j. Connect antenna lead-in wire to ships antenna wire at male/female connector (8) on bottom of antenna.
- k. Draw down neoprene weathershield (9) over the connection.

**NOTE**

**Lube Oil Purifier not applicable to vessels with Waste Heat Evaporator upgrade MWO 55-1905-223-55-3 installed. Paragraphs 2-17 through 2-24, Figures 2-5 through 2-11 and pages 2-207 through 2-222 were deleted.**







## 2-25. Repair Diesel Fuel Oil Filter/Separator.

---

This task covers: a. Disassembly, b. Repair, c. Assembly.

---

### INITIAL SETUP

#### Tools

Tool Kit, General Mechanic's,  
5180-00-699-5273  
Torque Wrench Kit P/N 3377216

#### Equipment Condition

Shut down - TM 55-1905-223-10.

#### Materials/Parts

Stud Seal P/N 201333 (2)  
Filter Element P/N 600616  
Fluid Filter Element P/N 600617  
Differential Pressure Gauge P/N 202327

---

### DISASSEMBLY

- a. Close inlet valve diesel fuel oil (8, Figure 2-12) to filter/separator.
- b. Slowly open vent valve (10) on top of unit to relieve pressure in housing.
- c. Open drain valve (7) and completely drain out.
- d. Loosen four hex nuts and remove swing bolts (2) from machining end cap (1).

### WARNING

**Secure the machining end cap with a chain or rope when in the open position in order to prevent injury to personnel by inadvertent closing.**

- e. Lift machining end cap (1) by handle and swing back into a rest position.
- f. Remove hexagon self-locking nuts (3), flatwashers (4) and stud seals (5) from each of two fluid filter elements (6) and (9).
- g. Remove fluid filter elements (6) and (9).
- h. Loosen the two tube coupling nuts (1, Figure 2-13).
- i. Gently press the tubing (3) against the differential pressure gauge (4) and pull up on the tube coupling nuts (1) to break the seal between the nut and tube.

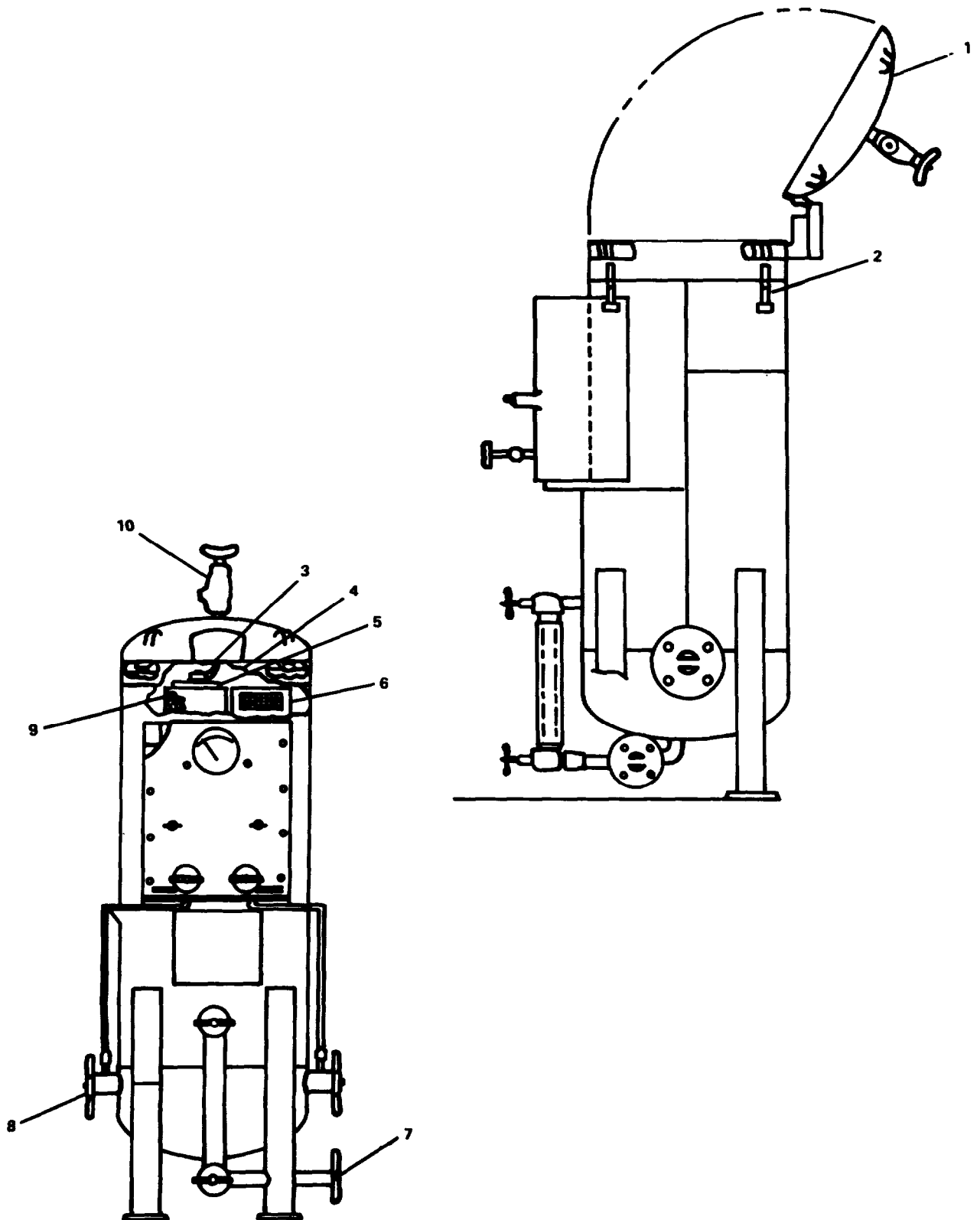


Figure 2-12. Diesel Fuel Oil Filter/Separator.

- j. Remove the hexagon cap screws and self-locking nuts (2) that secure the gauge to the panel.
- k. Gently pull the gauge away from the panel.

### REPAIR

Repair of the diesel fuel oil filter/separator at the unit level is the replacement of the differential pressure gauge, fluid filter elements and stud seals.

### ASSEMBLY

- a. Install the differential pressure gauge (4, FIGURE 2-13) by replacing the hexagon cap screws and self-locking nuts (2).
- b. Install the tubes to the differential pressure gauge (4) by tightening the tube coupling nuts (1).
- c. Install fluid filter elements (6 and 9, FIGURE 2-12).
- d. Install stud seals (5), flatwashers (4) and hexagon self-locking nuts (3).
- e. Close the machining end cap (1) and secure with swing bolts (2). Torque hexagon nuts to 35 ft-lbs.
- f. Close drain valve (7).
- g. Make sure vent valve (10) is open. Open inlet valve (8) and when all air has escaped from filter housing, shut vent valve (10).
- h. Test system.

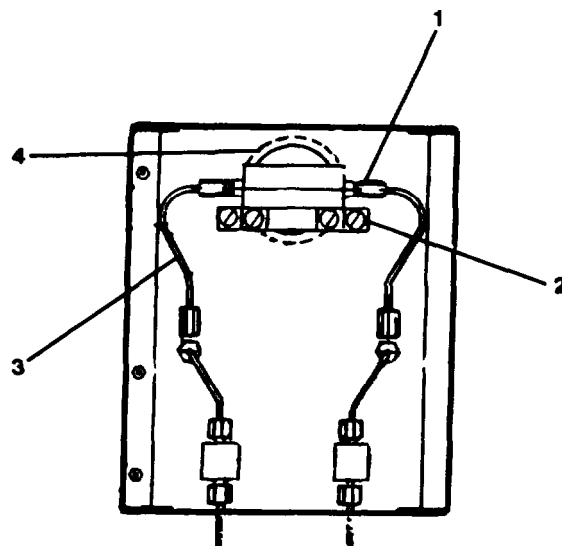


FIGURE 2-13. Diesel Fuel Oil Filter/Separator. Assembly.

**NOTE**

Paragraphs 2-26 through 2-30 are not applicable to vessels with OWS upgrade, MWO 55-1905-223-55-6. Reference TM 55-1905-223-24-19 for information for vessels that have the OWS upgrade MWO 55-1905-223-55-6 installed.

**2-26. Replace/Repair Motor Control Box Assembly. (FIGURE 2-14).**

This task covers:      a. Removal,      b. Repair,      c. Replacement.

**INITIAL SETUP****Tools**

Tool Kit, General Mechanic's,  
5180-00-699-5273

**Equipment Condition**

Electrical Power Turned OFF at Power  
Panel, Switch Tagged "Out of  
Service - Do Not Operate,"

**Materials/Parts**

Motor Control Box Assembly  
P/N 1282-L  
Cartridge Fuse P/N MDL-1/2  
Warning Tag, Item 1, Appendix C

**REMOVAL**

- a. Open hinged cover of motor control box assembly (1) by loosening two fasteners (2).
- b. Remove and tag electrical wires.
- c. Remove machine bolts (4), plain hexagon nuts (6) and lockwashers (5) holding motor control box assembly (1) to first stage vessel bracket.

**REPAIR**

- a. Remove cartridge fuse (3).
- b. Install new cartridge fuse (3).

**REPLACEMENT**

- a. Install motor control box (1) on first stage vessel bracket with machine bolts (4), lockwashers (5), and plain hexagon nuts (6).
- b. Install electrical wires and remove tags.
- c. Close hinged cover of motor control box assembly (1) and tighten two fasteners (2).
- d. Remove warning tag from power panel and restore power.

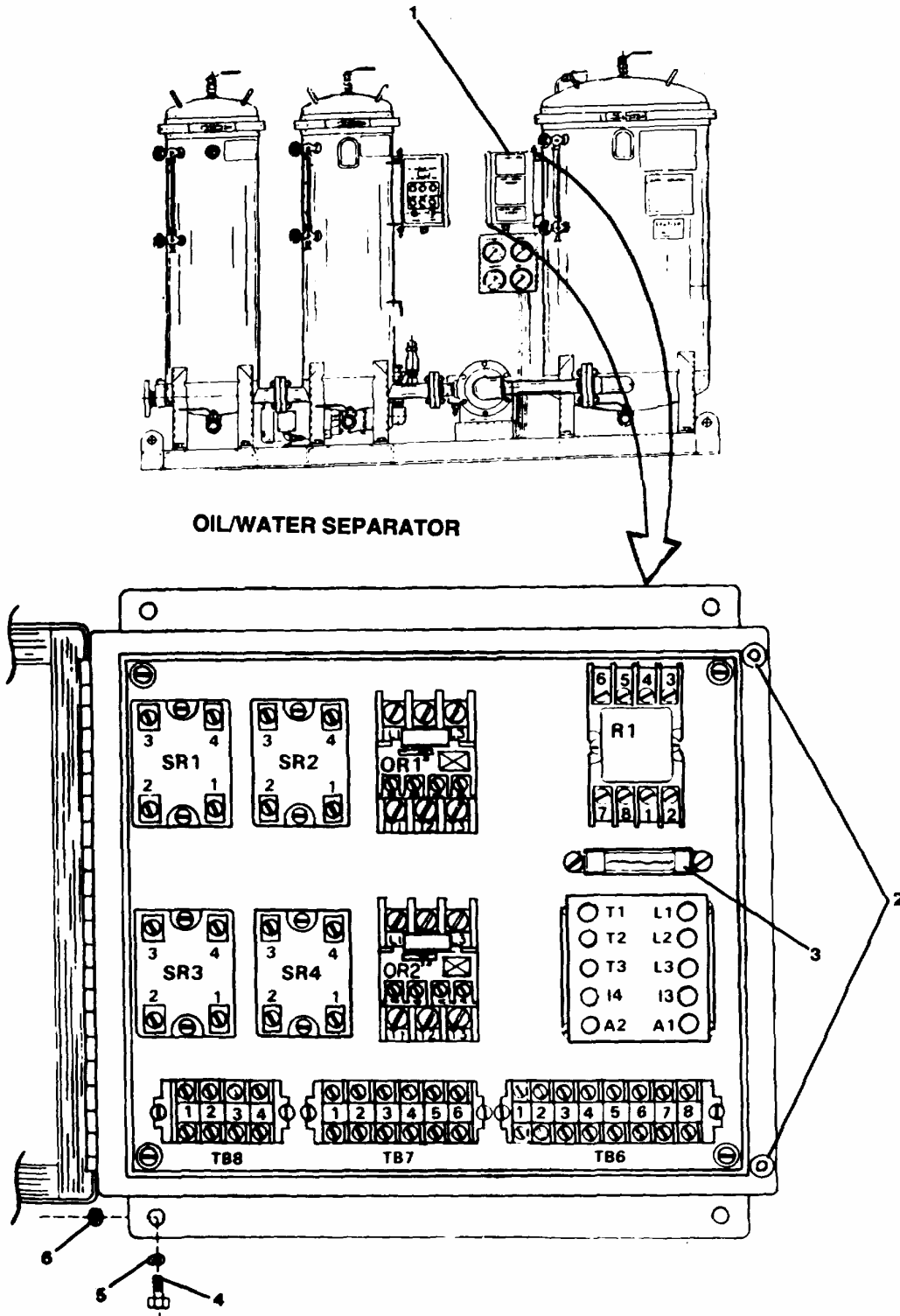


Figure 2-14. Motor Control Box Assembly.

---

## 2-27. Replace/Repair Gauge Panel Assembly. (FIGURE 2-15)

---

This task covers: a. Removal, b. Repair, c. Replacement.

---

### INITIAL SETUP

#### Tools

Tool kit, general mechanic's,  
5180-00-699-5273

#### Equipment Condition

Shut down - TM 55-1905-223-10  
Electrical power turned OFF at  
power panel, switch tagged "Out of  
Service - Do Not Operate."

#### Materials/Parts

Gauge panel assembly P/N 1284-2  
Dial indicating vacuum gauge P/N GG28  
Dial indicating pressure gauge P/N GG31  
Warning tag, Item 1, Appendix C

---

### REMOVAL

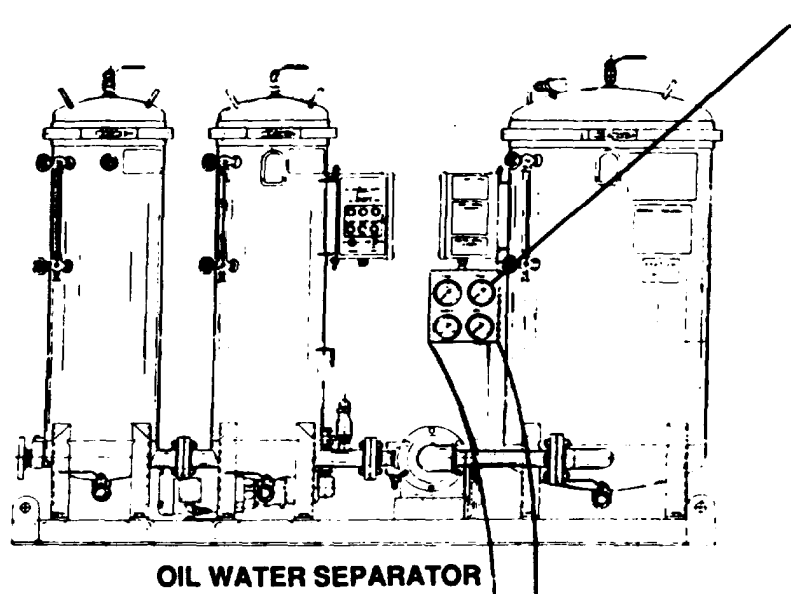
- a. On back of gauge panel (1), tag and disconnect sensor leads (2) to four gauges on panel.
- b. Remove three plain hexagon nuts, lockwashers and machine bolts (3) holding panel to bracket on first stage vessel.
- c. Remove gauge panel assembly.

### REPAIR

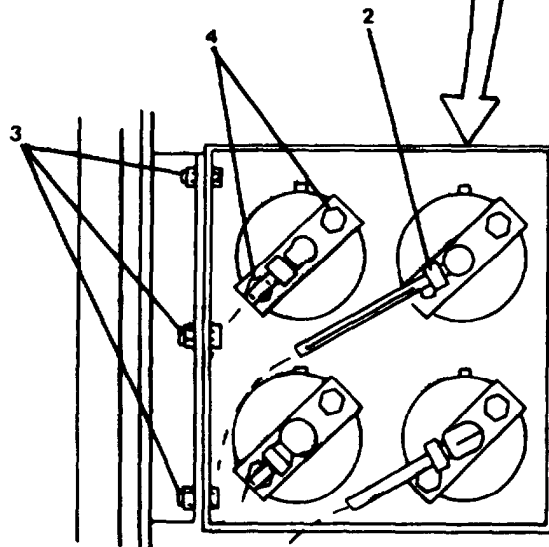
- a. Remove two securing bolts (4) from rear of each gauge.
- b. Slide gauge out of panel front.
- c. Install replacement gauge into panel.
- d. Secure gauge to panel with two bolts (4).

### REPLACEMENT

- a. Secure gauge panel assembly to bracket on first stage vessel with three machine bolts, lockwashers and plain hexagon nuts (3).
- b. On back of panel, remove tags and connect sensor leads (2) to four gauges on panel.
- c. Remove warning tag from power panel and restore power.



**OIL WATER SEPARATOR**



**REAR VIEW, GAUGE PANEL ASSEMBLY**

FIGURE 2-15. Gauge Panel Assembly.



---

## 2-28. Replace/Repair Control Module Assembly.

---

This task covers: a. Removal, b. Repair, c. Replacement.

---

### INITIAL SETUP

#### Tools

Tool kit, general mechanic's,  
5180-00-699-5273  
Tool kit, electrician,  
5180-00-391-1087

#### Equipment Condition

Shut down - TM 55-1905-223-10.  
Electrical power turned OFF at power  
panel, switch tagged "Out of Service  
- Do Not Operate."

#### Materials/Parts

Control module assembly P/N OCA-1A  
Incandescent lamp P/N 81007  
Cartridge fuse P/N 50016  
Warning tag, Item 1, Appendix C

---

### REMOVAL (FIGURE 2-16)

- a. Open hinged cover (2) of control module assembly.
- b. Tag and disconnect all wiring from five terminal boards (4) and lug E9 (3).
- c. Remove machine bolts (7), lock washers (6) and plain hexagon nuts (8) securing control module assembly to bracket on second stage vessel.
- d. Remove control module assembly.

### REPAIR (FIGURE 2-16)

- a. Replace Incandescent Lamp.
  - (1) Unscrew lens cap (5) from incandescent lamp.
  - (2) Unscrew lamp and remove.
  - (3) Screw replacement lamp into socket.
  - (4) Replace lens cap (5).
- b. Replace Cartridge Fuse.
  - (1) Turn fuse holder cap (1) counterclockwise to release and remove cartridge fuse.

- (2) Install replacement cartridge fuse into fuse holder cap (1), insert into fuse holder and turn fuse holder cap (1) clockwise to secure.

REPLACEMENT (FIGURE 2-16)

a. Replace Control Module Assembly.

- (1) Attach control module assembly to bracket on second stage vessel with machine bolts (7), lock washers (6) and plain hexagon nuts (8).
- (2) Remove tags and reconnect all wiring to five terminal boards (4) and lug E9 (3).
- (3) Remove warning tag from power panel and restore power.

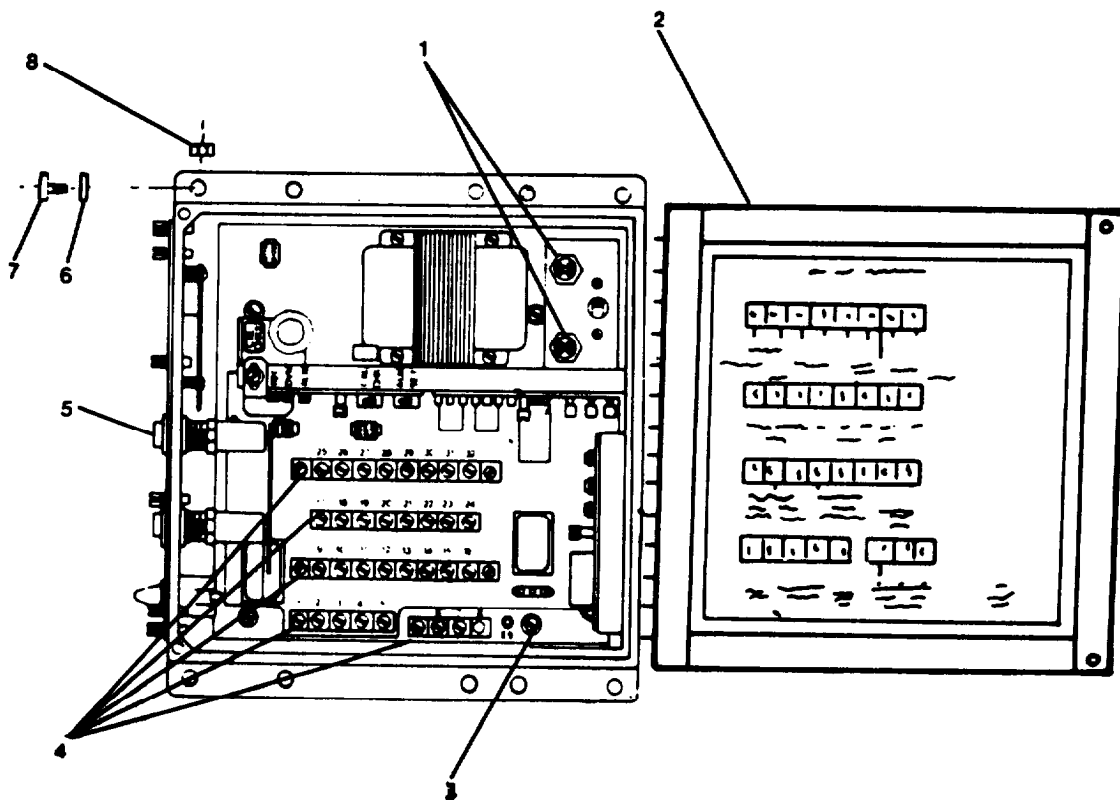


FIGURE 2-16. Repair Control Module.

Calibration (FIGURE 2-17)

a. Calibrate Oil Content Alarm.

- (1) Turn power switch (1) on.

**WARNING**

Exercise extreme care while working on electrical components inside control module. Accidental contact with energized components may result in injury to personnel or equipment damage.

- (2) Hold alarm set switch (2) in SET.
- (3) Turn alarm set point adjustment screw (3) until desired reading is obtained on digital display (4). Desired reading is indicated by calibration number (4).
- (4) Perform system start up as detailed in TM 55-1905-223-10 (Operator's Manual).
- (5) Run clean water having a zero ppm value through sensing module.
- (6) Attach leads of test meter to terminal contacts 27(+) and 28(-) of control module (6).
- (7) When conditions have stabilized, a reading of 0 Vdc should be obtained. See Table 2-5.

Table 2-5. Control Module Output Voltage for ppm.

ppm Indication (ppm)	Output Voltage (dc volts)
100	10
50	5
10	1
5	0.5
0	0

- (8) Release and swing aside Receive (REC) and Digital Voltmeter (DVM) adjustment guard (7).
- (9) Calibrate output as indicated above by adjusting recorder adjustment screw (8) for 10 ppm.
- (10) Adjust digital voltmeter (DVM) adjustment screw (9) to 1 Vdc value on digital display (4). Unit is now calibration to read ppm.
- (11) Reinstall REC and DVM adjustment guard (7) in original position.

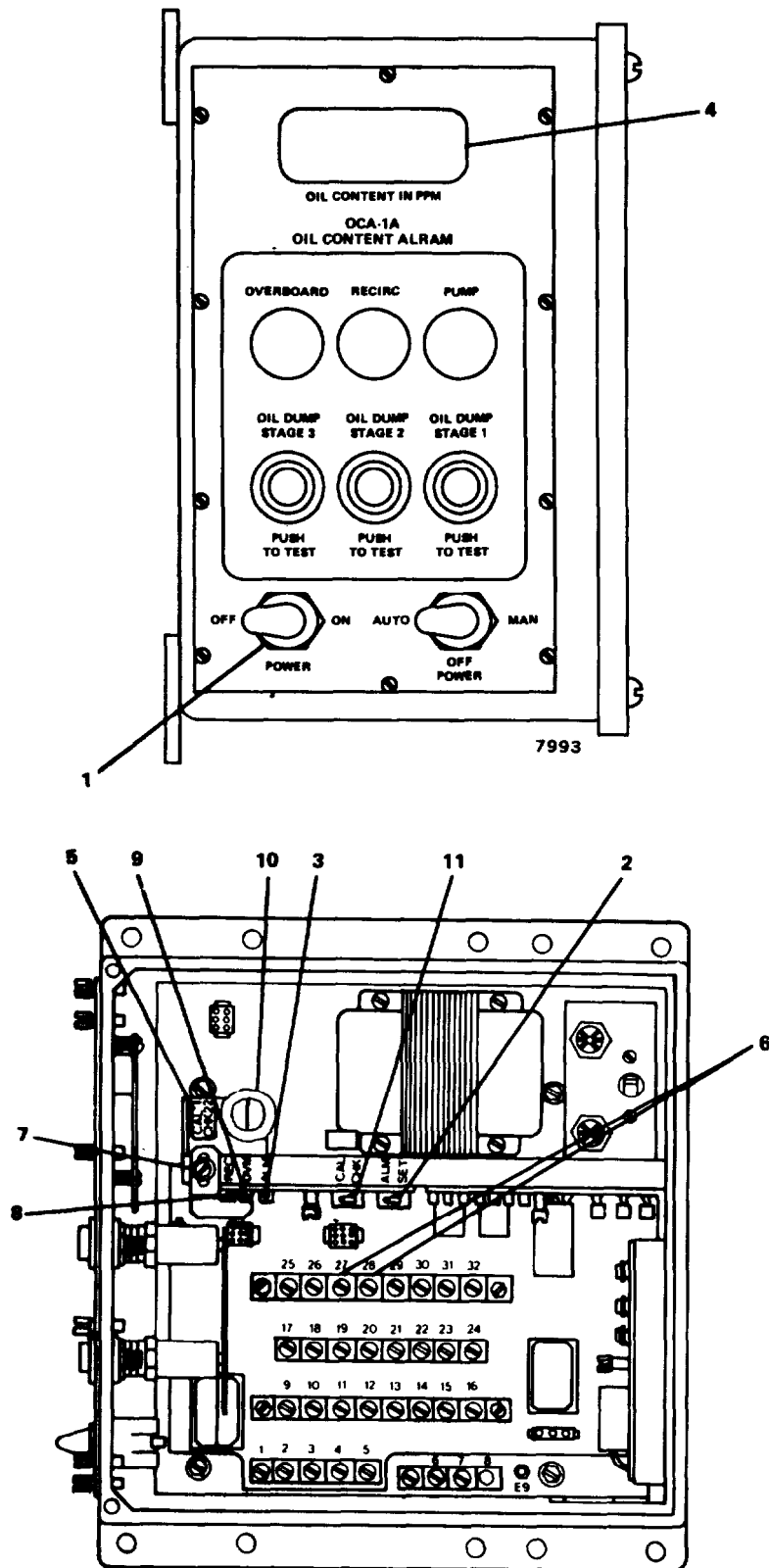


FIGURE 2-17. Control Module.

- (12) When oil-free water clarity changes, this change can be calibrated out by running a sample of the oil-free water through unit and adjust zero adjustment knob (10) to obtain reading of 00 on digital display (4).

**NOTE**

Release knob lock before attempting to turn knob.

- (13) Depress CAL check switch (11) and reestablish calibration check number (5).
- (14) Close side panel of control module.

2-29. Repair Vessel Subassembly (3rd Stage).

---

This task covers: a. Disassembly, b. Repair, c. Assembly.

---

**INITIAL SETUP**

**Tools**

Tool kit, general mechanic's,  
5180-00-699-5273

**Materials/Parts**

Self-locking wing nut P/N NU75  
Packing retainer P/N OR80  
Preformed packing P/N OR40  
Coalescer element P/N 622-100  
Warning tag, Item 1, Appendix C

---

**Equipment Condition**

Oil/water separator secured at the  
miscellaneous machinery power panel  
and tagged "Out of Service - Do Not  
Operate."

**DISASSEMBLY**

a. **Drain Third Stage Vessel.**

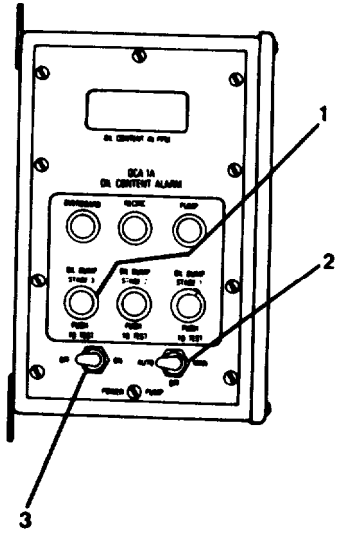
- (1) Press OIL DUMP, STAGE 3 button (1, Figure 2-18) on control module to drain oil from vessel.
- (2) When complete, turn PUMP selector switch (2) off.
- (3) Turn POWER switch (3) off.
- (4) Open vent valve (4, FIGURE 2-19) on top of third stage vessel.
- (5) Open drain valve (7) on bottom of third stage vessel.
- (6) When drainage is complete, close vent valve (4) and drain valve (7).

b. **Disconnect Electrical Power.**

- (1) Turn off electrical power to oil/water separator at the miscellaneous machinery power panel.
- (2) Tag switch "Out of Service - Do Not Operate."

**NOTE**

Cover must be opened before coalescer element is removed.



9173

FIGURE 2-18. CONTROL MODULE.

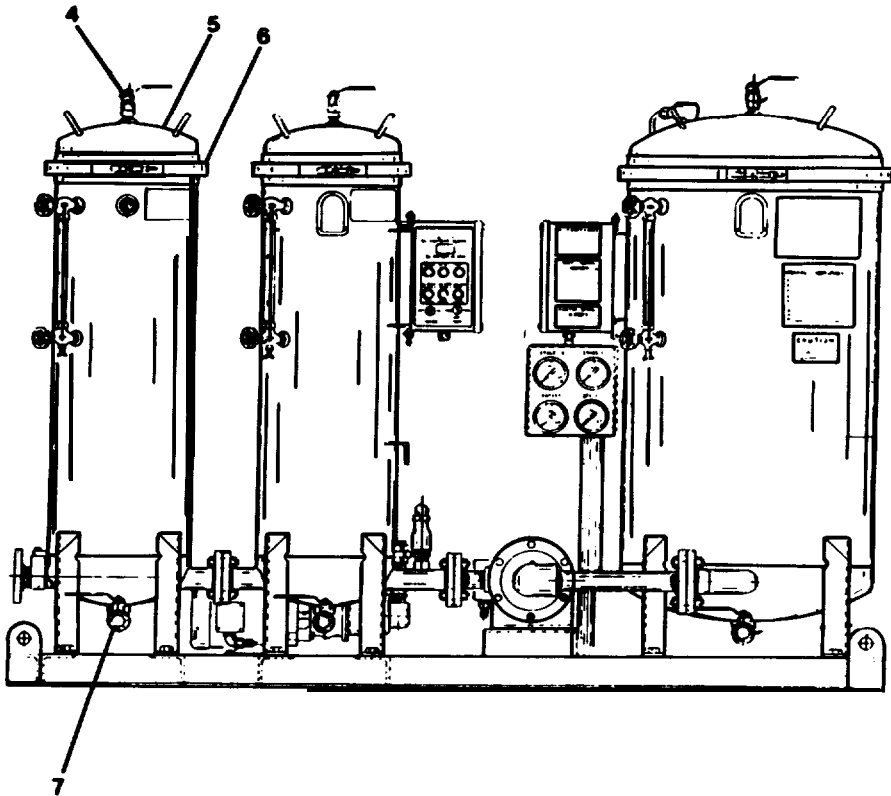


FIGURE 2-19. Oil/Water Separator.

c. Remove Coalescer Element.

**CAUTION**

Wait until water has drained below the level of the cover before opening the cover.

- (1) Loosen and remove clamp (9, FIGURE 2-20) securing cover (8) to third stage vessel.
- (2) Remove cover (8).
- (3) Loosen and remove wing nut (3) from threaded filter support (6).
- (4) Remove packing retainer (2), preformed packing (4) and hold down plate (1).
- (5) Remove coalescer element (5).

**REPAIR**

Repair at the unit level consists of cleaning the inside of the 3rd stage vessel and replacing the coalescer element (5), preformed packing (4), packing retainer (2), and self-locking wing nut (3).

**ASSEMBLY**

**CAUTION**

It is important that coalescer element be handled properly. DO NOT touch or handle the sock area (side covering) of the coalescer. Contamination of this surface by any oils, including skin oils, may prevent the coalescer element from functioning properly and cause foaming in the effluent. Handle coalescer element only by the end cap. When installing element, insert hand through opening on the end cap.

- a. Place coalescer element (5) over the threaded support (6) so that it is centered over the element positioning guide (7).
- b. Replace and center hold down plate (1) over end cap of the coalescer element,
- c. Replace preformed packing (4), packing retainer (2) and self-locking wing nut (3).
- d. Tighten self-locking wing nut (3) as tightly as possible by hand. There are no torque requirements.



**CAUTION**

DO NOT use a wrench to tighten self-locking wing nut or the coalescer element will be damaged.

- e. Replace cover (8) and preformed packing (10).
- f. Replace clamp (9) securing cover and tighten. There are no torque requirements.
- g. Remove warning tag from power panel and restore power.
- h. Restore to normal operation. Refer to TM 55-1905-223-10.

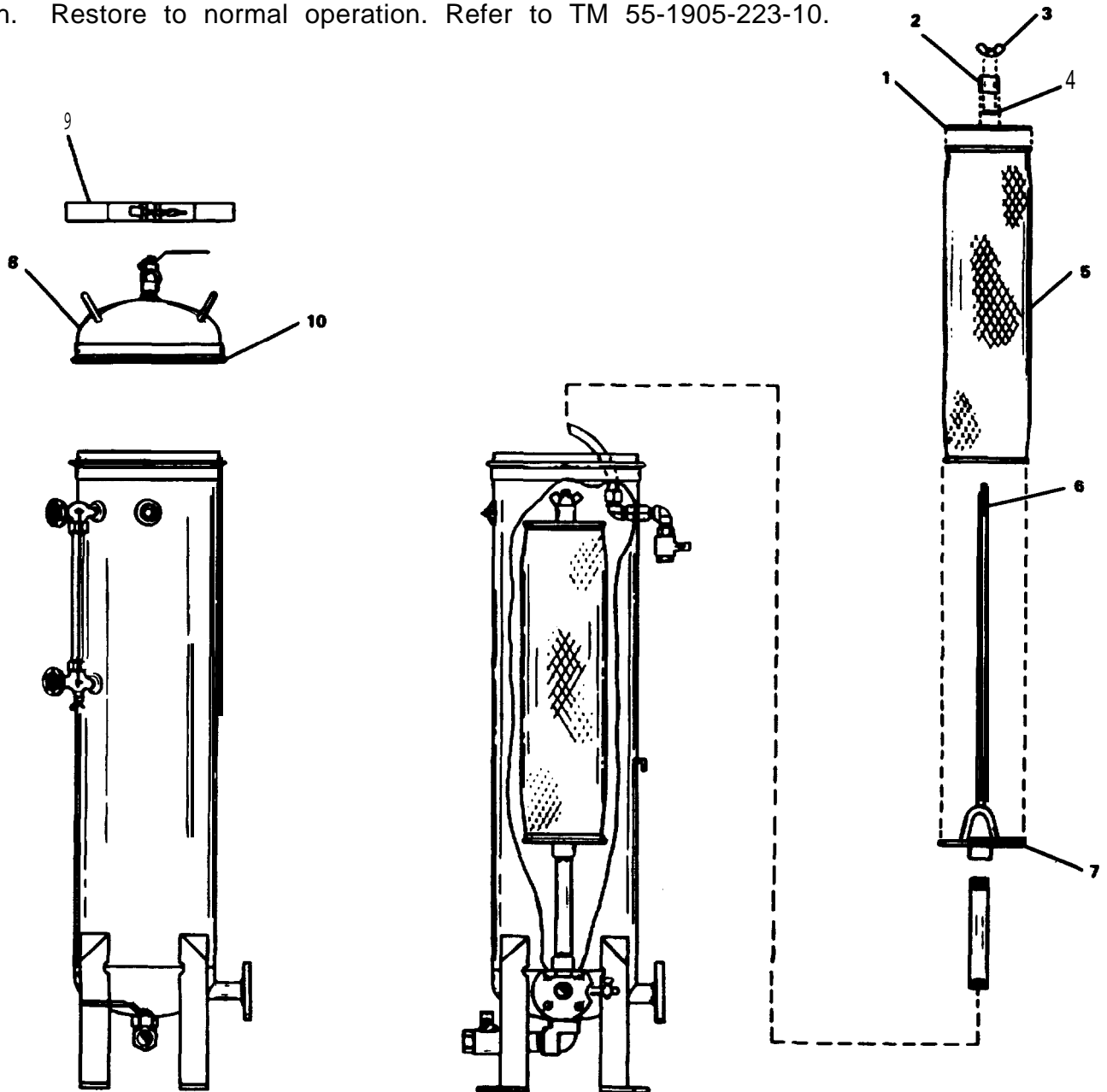


FIGURE 2-20. Vessel Subassembly (3rd Stage).

2-30. Repair Vessel Subassembly (2nd Stage).

---

This task covers: a. Disassembly, b. Repair, c. Assembly.

---

**INITIAL SETUP**

**Tools**

Tool kit, general mechanic's,  
5180-00-699-5273

**Equipment Condition**

Oil/water separator secured at  
miscellaneous machinery power panel  
and tagged "Out of Service - Do Not  
Operate."

**Materials/Parts**

Preformed packing P/N GA19  
Preformed packing P/N OR40  
Liquid quantity transmitter  
P/N 392  
Packing retainer P/N OR80  
Fluid filter element P/N 614-505  
Warning tag, Item 1, Appendix C

---

**DISASSEMBLY**

a. Drain Second Stage Vessel.

- (1) Press OIL DUMP, Stage 2 button (1, FIGURE 2-21) on control module to drain oil from vessel.
- (2) When complete, turn PUMP selector switch (2) off.
- (3) Turn POWER SWITCH (3) OFF.
- (4) Open vent valve (1, FIGURE 2-22) on top of second stage vessel.
- (5) Open drain valve (4) on bottom of second stage vessel.
- (6) When drainage is complete, close vent valve (1) and drain valve (4).

b. Disconnect Electrical Power.

- (1) Turn off electrical power to oil/water separator at the miscellaneous machinery power panel.
- (2) Tag switch "Out of Service - Do Not Operate."

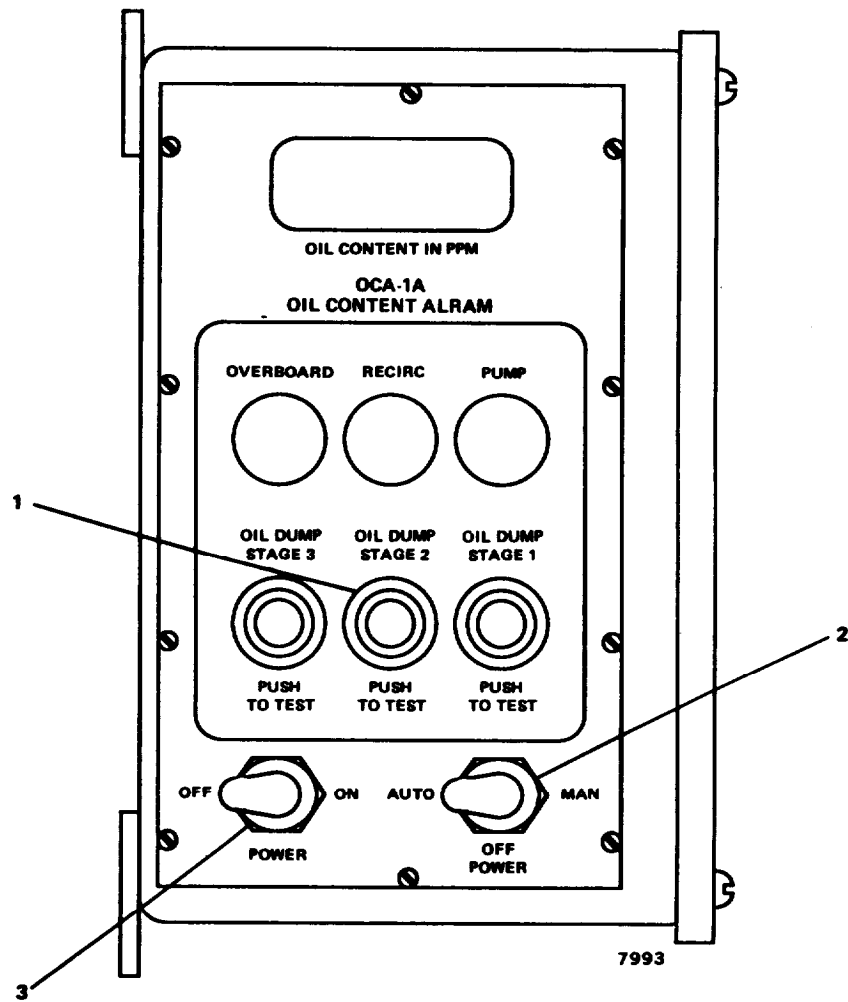


FIGURE 2-21. Control Module.

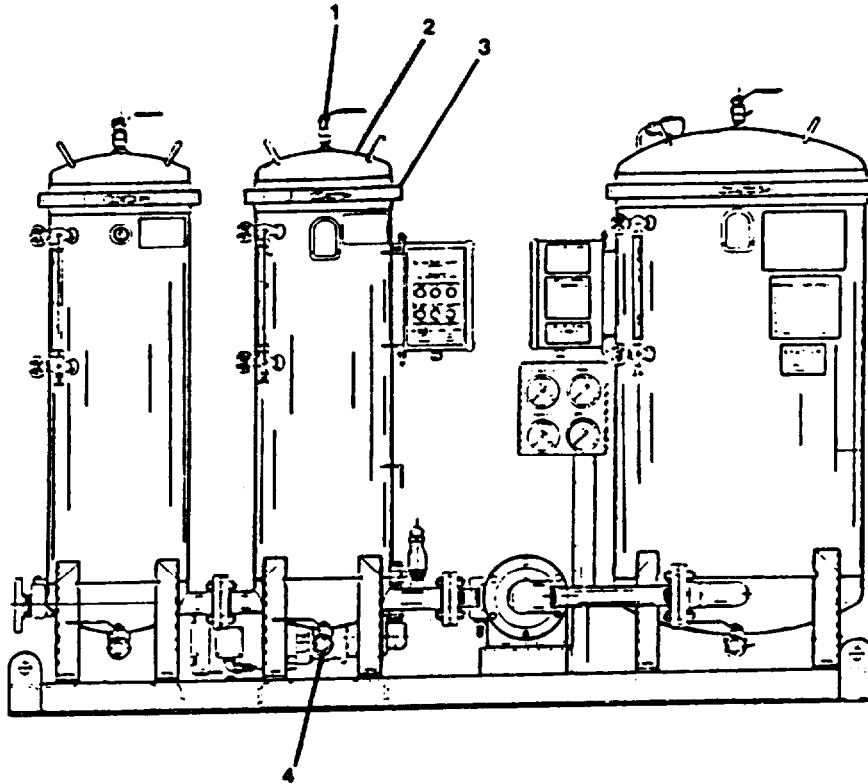


FIGURE 2-22. Oil/Water Separator.

c. Remove Filters.

**CAUTION**

Wait until water has drained below the level of the cover before opening the cover.

- (1) loosen and remove clamp (11, FIGURE 2-23) securing cover (10) to second stage vessel.
- (2) Remove cover (10) and preformed packing (9).
- (3) loosen and remove self-locking wing nut (1) from threaded filter support (6).
- (4) Remove packing retainer (2), preformed packing (3) and hold down plate (4).
- (5) Remove fluid filter elements (5) and (12).
- (6) Unscrew and remove liquid transmitter cover (8).
- (7) Tag and disconnect wires attached to transmitter terminals.
- (8) Unscrew liquid transmitter (7).

**REPAIR**

- a. Repair at the unit level consists of cleaning the inside of the second stage vessel and replacing the liquid transmitter (7), packing (3), retainer (2), preformed packing (9) and fluid filter elements (5 and 12).
- b. Thoroughly flush and clean inside of second stage vessel with water.

**ASSEMBLY****CAUTION**

It is important that filter elements be handled properly. DO NOT touch or handle the sock area (side covering) of the filter element. Contamination of this surface by any oils, including skin oils, may prevent the filter element from functioning properly and cause foaming in the effluent. Handle filter element only by the end cap. When installing element, insert hand through opening on the end cap.

- a. Place fluid filter elements (15) and (12) over the threaded filter support (6).
- b. Replace and center hold down plate (4) over end cap of top filter element (5).
- c. Replace preformed packing (3), packing retainer (2), and self-locking wing nut (1).
- d. Tighten self-locking wing nut as tightly as possible by hand. There are no torque requirements.

**CAUTION**

DO NOT use a wrench to tighten wing nut or the filter elements will be damaged.

- e. Replace cover (10) and preformed packing (9).
- f. Replace clamp (11) securing cover (10) and tighten. There are no torque requirements.
- g. Replace liquid transmitter (7).
- h. Remove tags and connect wires to liquid transmitter terminals.
- i. Replace liquid transmitter cover (8).
- j. Remove warning tag from power panel and restore power.

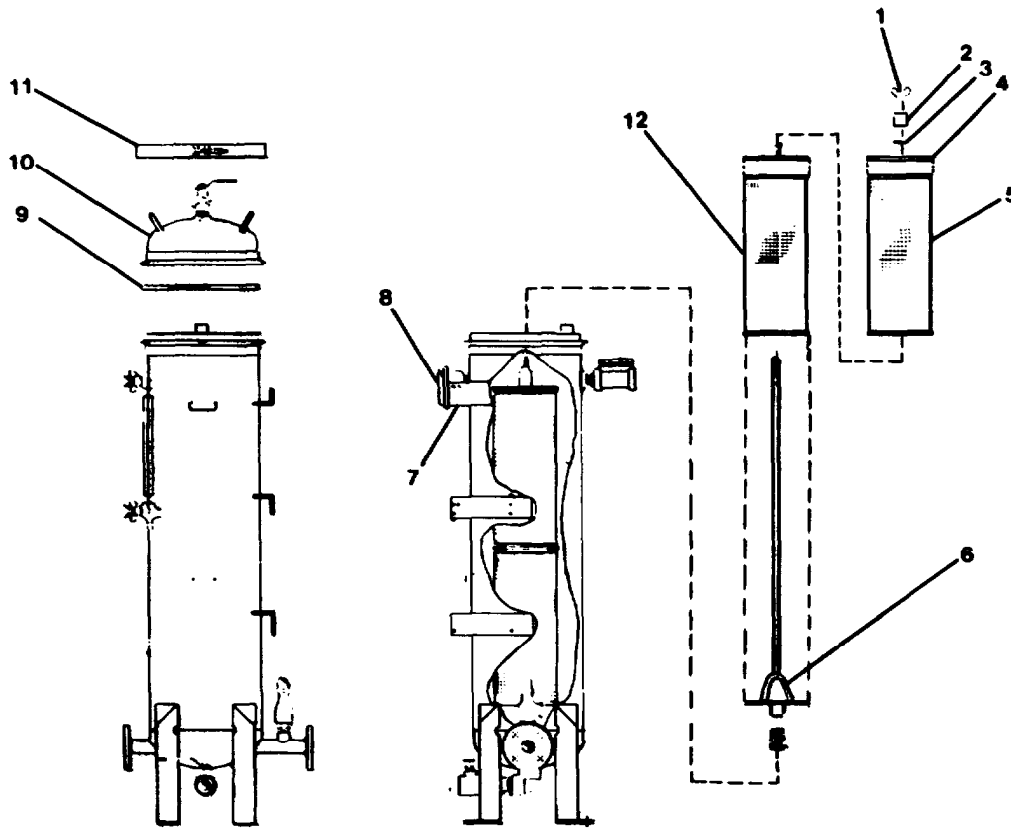


FIGURE 2-23. Filter Removal (2nd Stage).

MAINTENANCE OF SOUND POWERED TELEPHONE SYSTEM
---

---

2-31. Replace/Repair Sound Powered Telephone. (FIGURE 2-24)

---

This task covers: a. Removal, b. Repair, c. Replacement.

---

### INITIAL SETUP

#### **TOOLS**

Tool kit, electrician's,  
5180-00-391-1087

#### **Equipment Condition**

Electrical power turned OFF at power panel and tagged "Out of Service - Do Not Operate."

#### **Materials/Parts**

Sound powered telephone P/Ns

SER(MOD)-19,  
SELR(MOD)-19,  
SER(MOD)-8,  
SELR(MOD)-8,  
MWT-R-19,  
MWT-R-8,  
SFLR(MOD)-19

Handset P/N H-203/U

Headset-chest set P/N H-200/U

Warning tag, Item 1, Appendix C

---

#### **NOTE**

The sound powered telephone system consists of seven similar sound powered telephones that contain identical handsets and headset-chest sets. Refer to the nameplate on the front of the sound powered telephone for its model number which is also its part number.

### **REMOVAL**

- a. Remove headset-chest set (1) by disconnecting plug (2) from receptacle (8) on jackbox (9).
- b. Remove handset (6) by disconnecting telephone cord guard (5).
- c. Remove sound powered telephone, all models, by removing screws (7) and removing front cover (3).
- d. Tag and disconnect electrical leads from sound powered telephone (3).

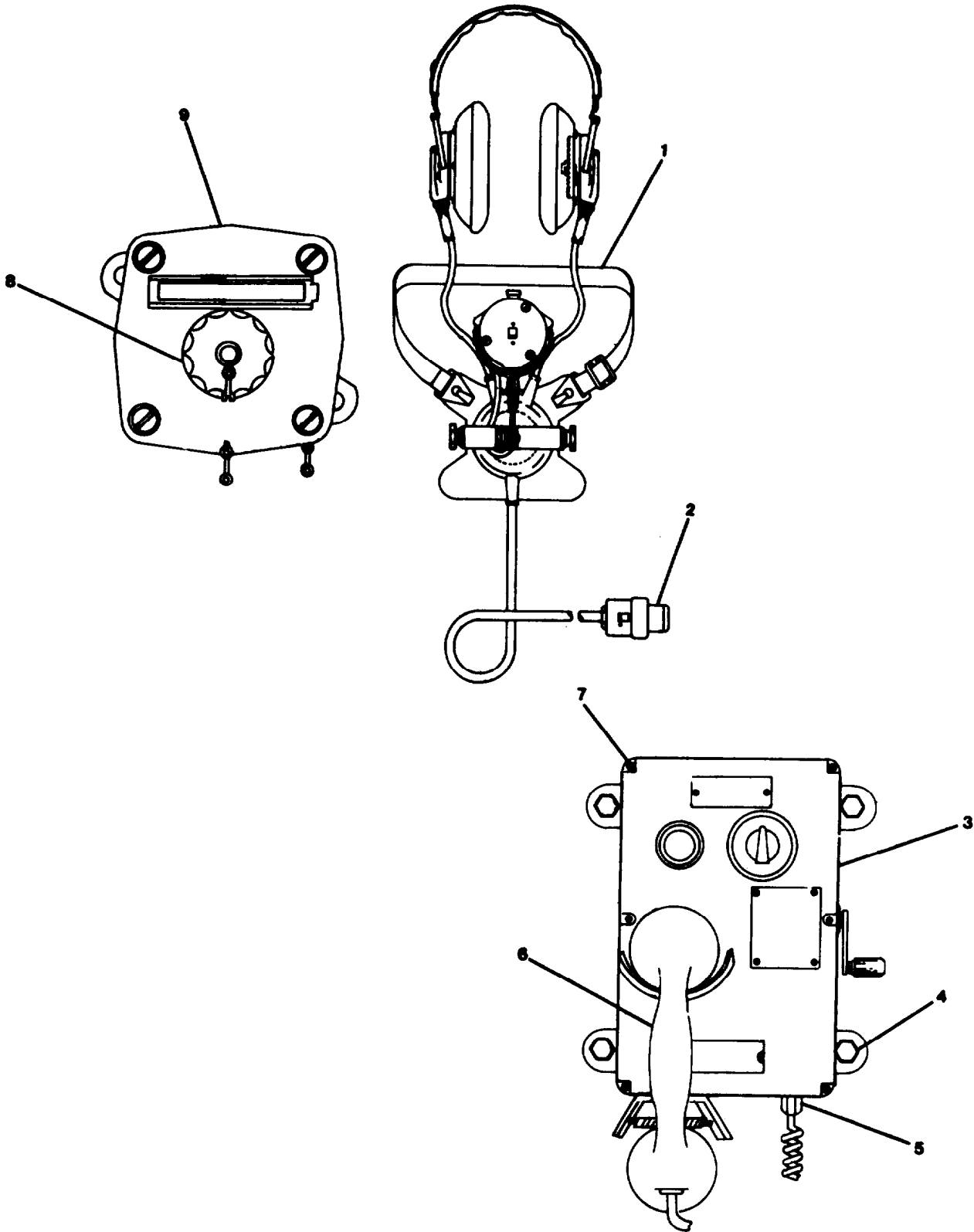


FIGURE 2-24. Sound Powered Telephone.



- e. Remove hex head screws (4) securing telephone set to bulkhead.
- f. Remove sound powered telephone (3).

### **REPAIR**

Repair of the sound powered telephone, headset, and headset-chest set at the unit level is by replacement.

### **REPLACEMENT**

- a. Replace sound powered telephone (3). Secure to bulkhead with hex head screws (4).
- b. Remove tags and connect electrical leads to sound powered telephone.
- c. Replace cover and secure with screws (7).
- d. Remove tag and turn on electrical power at circuit breaker panel serving telephone that has been replaced.
- e. Replace sound powered telephone head set - chest set (1). Connect head set - chest set (1) to jackbox (9) by pushing plug (2) into receptacle (8).

MAINTENANCE OF TANK LEVEL INDICATOR SYSTEM

---

2-32. Repair Receiver Module, RE-39240. (FIGURE 2-25)

---

This task covers: a. Removal, b. Repair, c. Replacement.

---

INITIAL SETUP

Tools

Tool kit, electrician's,  
5180-00-391-1087

Materials/Parts

Indicator light P/N  
LH89/1-LC35RT2 (14), 37075  
Fuse cartridge P/N F03A  
250V2A5 (2)  
Incandescent lamp P/N 36843

Equipment Condition

Electrical power to tank level  
indicator system turned OFF at  
Panel L102. Tag switch "Out of  
Service - Do Not Operate."  
Front panel opened as specified in  
paragraph 3-44.

---

REMOVAL

a. Indicator Light.

- (1) Unscrew and remove indicator light (1).
- (2) Remove remaining indicator lights.

b. Fuse Cartridge.

- (1) Unscrew fuse cartridge (2) from fuseholder (3).
- (2) Remove fuse cartridge.

c. Indicator Light.

- (1) Unscrew and remove indicator light (4).
- (2) Remove incandescent lamp (5) from front panel.

d. Fuse Cartridge.

- (1) With front panel opened as specified in paragraph 3-44, unscrew fuse cartridge (6) from fuse holder (7).
- (2) Remove fuse cartridge.

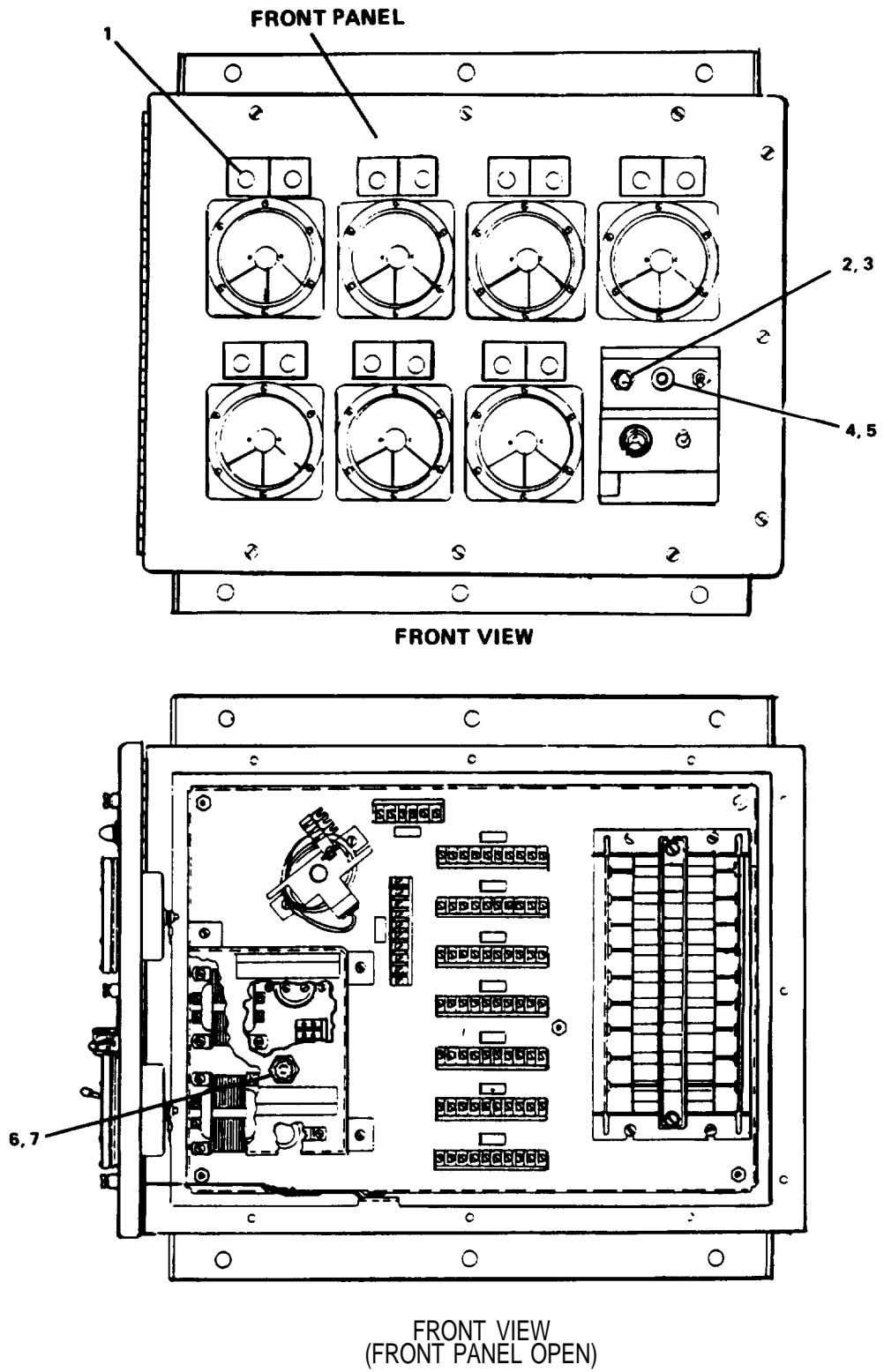


FIGURE 2-25. Receiver Module, RE-39240-7/M1-M7-38100.

**REPAIR**

Repair of receiver module consists of replacing: indicator light (1, 4), incandescent lamp (5), fuse cartridge (2, 6).

**REPLACEMENT**

a. With Front Panel Opened as Specified in Paragraph 3-44.

- (1) Position fuse cartridge (6) and fuse over fuseholder.
- (2) Install fuse cartridge and fuse into fuseholder.
- (3) Close front panel as specified in paragraph 3-44.

b. Indicator Light.

- (1) Install incandescent lamp (5) on front panel.
- (2) Install indicator light (4) on front panel.

c. Fuse Cartridge.

- (1) Position fuse cartridge (2) and fuse over fuseholder (3).
- (2) Install fuse cartridge into fuseholder.

d. Indicator Light

- (1) Position and screw indicator light (1) into front panel.
- (2) Install remaining indicator lights.
- (3) Turn ON electrical power at panel L102.

---

2-33. Repair Receiver Module, RR-39260. (FIGURE 2-26)

---

This task covers: a. Removal, b. Repair, c. Replacement.

---

### INITIAL SETUP

#### Tools

Tool kit, electrician's,  
5180-00-391-1087

#### Materials/Parts

Indicator light P/N  
LH89/1-LC35RT2 (24), 37075  
Fuse cartridge P/N F03A  
250V2A5 (3)  
Incandescent lamp P/N 36843

#### Equipment Condition

Electrical power to tank level  
indicator system turned OFF at  
Panel L102. Tag switch "Out of  
Service - Do Not Operate."  
Front panel opened as specified in  
paragraph 3-45.

---

### REMOVAL

#### a. Indicator Light.

- (1) Unscrew and remove indicator light (1).
- (2) Remove remaining indicator lights.

#### b. Fuse Cartridge.

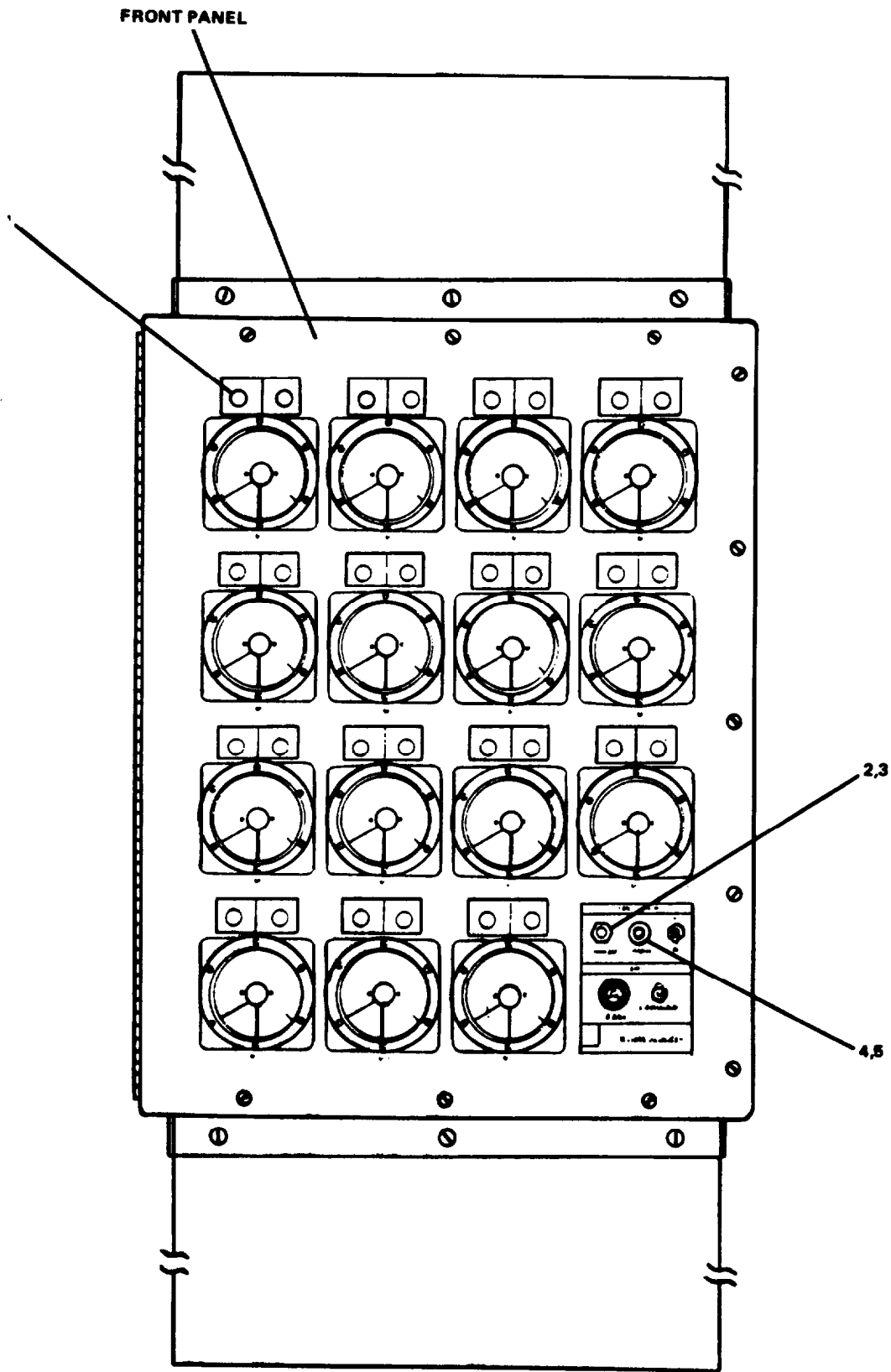
- (1) Unscrew fuse cartridge (2) from fuseholder (3).
- (2) Remove fuse cartridge and fuse.

#### c. Indicator Light.

- (1) Unscrew and remove indicator light (4).
- (2) Remove incandescent lamp (5) from front panel.

#### d. Fuse Cartridge.

- (1) With front panel opened as specified in paragraph 3-45, unscrew fuse cartridge (6) from fuse holder (7).
- (2) Remove fuse cartridge and fuse.



FRONT VIEW

FIGURE 2-26. Receiver Module. RE-39260-12/M1-M8-38100/M9-M12- 38139  
(Sheet 1 of 2)

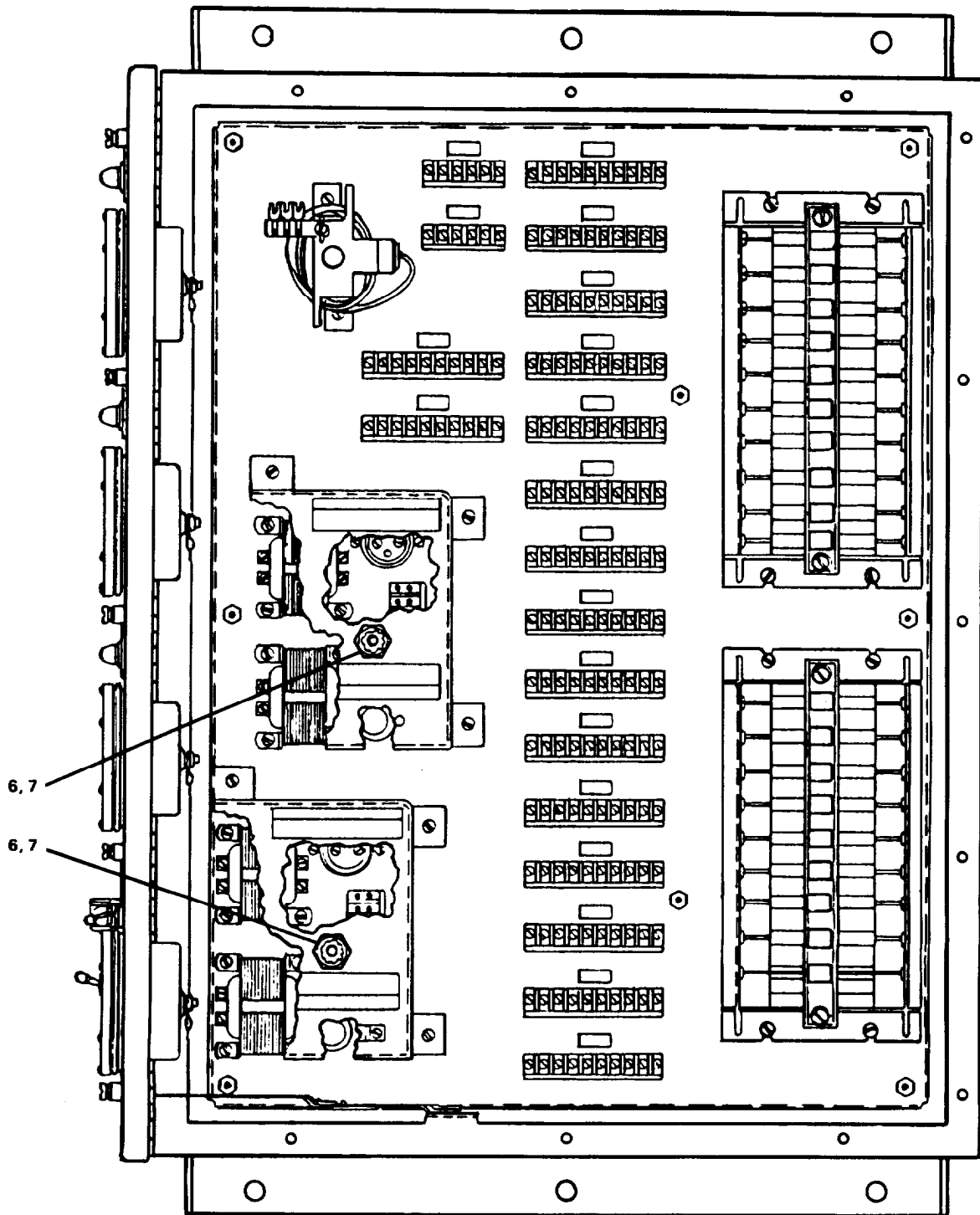


FIGURE 2-26. Receiver Module, RE-39260-12/M1-M8-38100/M9-M12-38139 (Sheet 2 of 2).

---

**REPAIR**

Repair of receiver module consists of replacing: indicator light (1, 4), incandescent lamp (5), fuse cartridge (2, 6).

---

**REPLACEMENT**

- a. With Front Panel Opened as Specified in Paragraph 3-45.
  - (1) Position fuse cartridge (6) and fuse over fuseholder.
  - (2) Install fuse cartridge and fuse into fuseholder.
  - (3) Close front panel as specified in paragraph 3-45.
- b. Indicator Light
  - (1) Install incandescent lamp (5) on front panel.
  - (2) Install indicator light (4) on front panel.
- c. Fuse Cartridge.
  - (1) Position fuse cartridge (2) and fuse over fuseholder (3).
  - (2) Install fuse cartridge and fuse into fuseholder.
- d. Indicator Light.
  - (1) Position and screw indicator light (1) into front panel.
  - (2) Install remaining indicator lights,
  - (3) Turn ON electrical power at panel L1O2.



---

## 2-34. Repair Receiver Module, RE-31326. (FIGURE 2-27)

---

This task covers: a. Removal, b. Repair, c. Replacement.

---

### INITIAL SETUP

#### Tools

Tool kit, electrician's,  
5180-00-391-1087

#### Materials/Parts

Alarm control fuse P/N 15483  
Indicator light P/N 37075  
Neon lamp P/N 41021  
Warning tag, Item 1, Appendix C

---

#### Equipment Condition

Electrical power to tank level  
indicator system turned OFF at  
Panel L102. Tag switch "Out of  
Service - Do Not Operate."

### REMOVAL

- a. Remove alarm control fuse (3).
- b. Remove indicator light (1).
- c. Remove neon lamp (2).

### REPAIR

Repair of receiver module consists  
of replacing: fuse (3), indicator  
light (1), neon lamp (2).

### REPLACEMENT

- a. Install neon lamp (2).
- b. Install indicator light (1).
- c. Install alarm control fuse (3).
- d. Restore electrical power to tank level  
indicator system at panel L102. Remove tag.

FIGURE 2-27.  
Receiver Module, RE-31326.

MAINTENANCE OF NAVIGATION SIGNALS AND SEARCHLIGHT

---

2-35. Replace Single Lens Navigation Light (Forward Anchor Light, Not Under Command Light-Upper, Not Under Command Light-Lower, Aft Anchor Light).

---

This task covers: a. Removal, b. Replacement.

---

INITIAL SETUP

Tools

Tool kit, general mechanic's,  
5180-00-699-5273

Equipment Condition

Electrical power turned OFF at  
navigation lights panel and switch  
tagged "Out of Service - Do Not  
Operate."

Materials/Parts

Marine navigation light  
P/N 3070009

Marine navigation light  
P/N 3070209

Warning tags, Item 1, Appendix C

---

REPLACEMENT

Refer to para. 2-36 for replacement.

- 
- 2-36. Repair Single Lens Navigation Light (Forward Anchor Light, Not Under Command Light-Upper, Not Under Command Light-Lower, Aft Anchor Light). (FIGURE 2-28)
- 

This task covers: a. Disassembly, b. Repair, c. Assembly

---

### INITIAL SETUP

#### Tools

Tool kit, general mechanic's,  
5180-00-699-5273

#### Materials/Parts

Gasket P/N 95800146  
Tungsten lamp  
P/N 90400290  
White lens P/N 83070017  
Red lens P/N 83070019  
Warning tags, Item 1, Appendix C

#### Equipment Condition

Electrical power turned OFF at navigation lights panel and switch tagged "Out of Service - Do Not Operate."

---

### NOTE

Marine navigation lights P/N 3070009 (forward and aft) and P/N 3070209 (not under command) are structurally identical. They differ in the color of the lens - white for forward and aft and red for not under command. This procedure is applicable to the four single lens marine navigation lights. When replacing the lens, be certain to use the correct replacement color (white or red).

### DISASSEMBLY

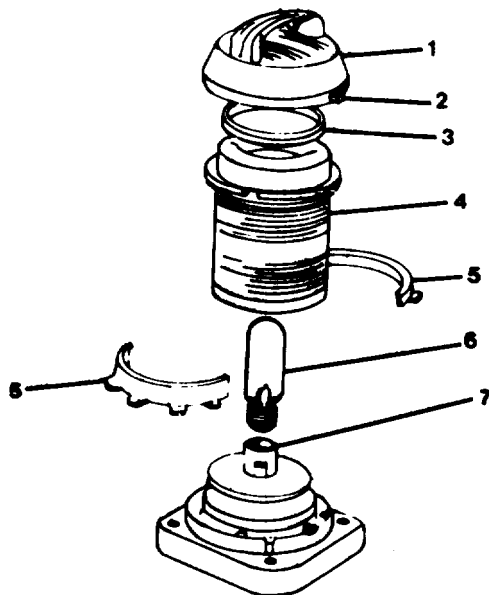
- a. Loosen set screw (2) and remove lid (1) and gasket (3).
- b. Unscrew and remove clamp (5).
- c. Remove lens (4).
- d. Unscrew and remove bulb (6) from socket (7).

REPAIR

Repair is by replacement of gasket, lamp, and lens.

ASSEMBLY

- a. Insert bulb (6) into socket (7) and secure.
- b. Position lens (4) on light and install clamp (5).
- c. Install lid (1) and gasket (3).
- d. Secure set screw (2) finger tight.
- e. Remove tag and turn on electrical power at navigation lights panel.



7801A

FIGURE 2-28. Single Lens Marine Navigation Light.

---

2-37. Replace Double Lens Navigation Light (Forward Masthead Light, Aft Masthead Light, Starboard Sidelight, Port Sidelight, Stern Light).

---

This task covers: a. Removal, b. Replacement.

---

### INITIAL SETUP

#### Tools

Tool kit, general mechanic's,  
5180-00-699-5273

#### Materials/Parts

Marine navigation light  
P/N 3076009

Marine navigation light  
P/N 3079109

Marine navigation light  
P/N 3078209

Marine navigation light  
P/N 3077009

Warning tags, Item 1, Appendix C

---

#### Equipment Condition

Electrical power turned OFF at navigation lights panel and switch tagged "Out of Service - Do Not Operate."

### REPLACEMENT

Refer to para. 2-38 for replacement.

---

2-38. Repair Double Lens Navigation Light (Forward Masthead Light, Aft Masthead Light, Starboard Sidelight, Port Sidelight, Stern Light). (FIGURE 2-29)

---

This task covers: a. Disassembly, b. Repair, c. Assembly

---

### INITIAL SETUP

#### Tools

Tool kit, general mechanic's,  
5180-00-699-5273

#### Equipment Condition

Electrical power turned OFF at navigation lights panel and switch tagged 'Out of Service - Do Not Operate.'

#### Materials/Parts

Gasket P/N 95800146  
Incandescent Lamp P/N 90400172  
White lens P/N 83070017  
Red lens P/N 83070019  
Green lens P/N 83075018  
Warning tags, Item 1, Appendix C

---

### NOTE

Marine navigation lights P/N 3076009 (forward and aft masthead lights), P/N 3079109 (starboard sidelight), P/N 3078209 (port sidelight), and P/N 3077009 (stern light) are structurally identical. They differ in the color of the lens - white for forward masthead, aft masthead, and stern, green for starboard sidelight, and red for port sidelight. This procedure is applicable to the five double lens marine navigation lights. When replacing the lens, be certain to use correct replacement color (white, green, or red).

### DISASSEMBLY

- a. Loosen set screw (2) and remove lid (1) and gasket (12).
- b. Unscrew and remove upper clamp (9).
- c. Remove upper lens (10) and screen (11).
- d. Loosen and remove upper bulb (3) from upper socket (4).
- e. Unscrew and remove lower clamp (6).

- f. Remove lower lens (5).
- g. Loosen and remove lower bulb (7).

## REPAIR

Repair is by replacement of gasket, lamps and lenses.

## ASSEMBLY

- a. Install lower bulb (7) into lower socket (8).
- b. Position lower lens (5) on light.
- c. Install lower clamp (6) and secure mounting screws.
- d. Install upper bulb (3) into upper socket (4).
- e. Position upper lens (11) on light and install clamp (9).
- f. Install lid (1) and gasket (12). Secure set screw (2) finger tight.
- g. Install screen (11) on upper lens (10).
- h. Remove tag and turn on electrical power at navigation lights panel.

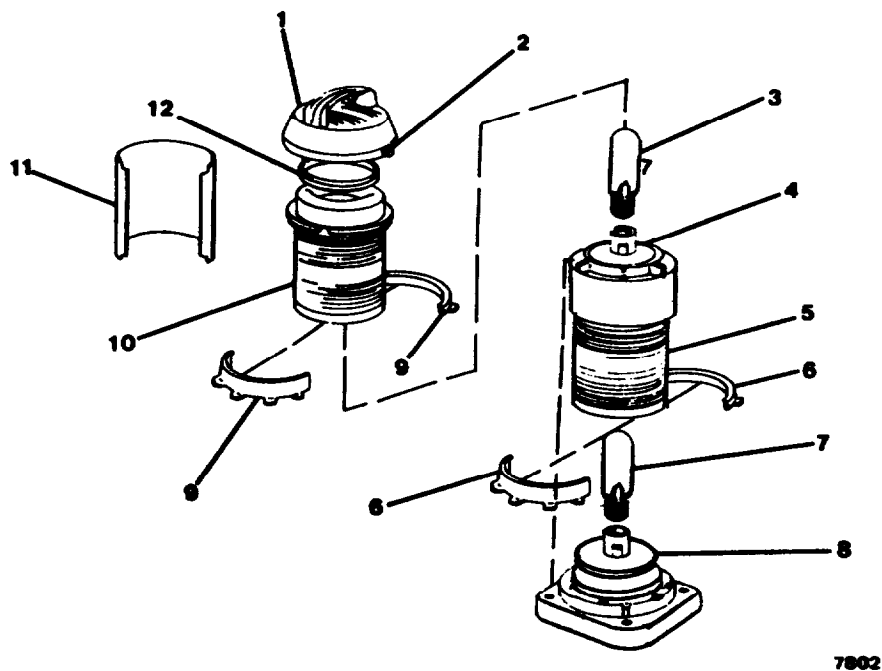


FIGURE 2-29. Double Lens Marine Navigation Light.

2-39. Replace/Repair Blinker Light. (FIGURE 2-30)

---

This task covers: a. Removal, b. Disassembly, c. Repair, d. Assembly  
e. Replacement.

---

INITIAL SETUP

Tools

Tool kit, general mechanic's,  
5180-00-699-5273

Equipment Condition

Power turned OFF at emergency lighting  
panel EL-102 and tagged "Out of  
Service - Do Not Operate."

Materials/Parts

Blinker light P/N 1453  
Gasket P/N GKT1032  
Gasket P/N GKT1005  
Gasket P/N GKT1016  
Incandescent lamp P/N A-19  
Lens P/N INK4034  
Navigational light control  
P/N M24174/3-001  
Warning tags, Item 1, Appendix C

---

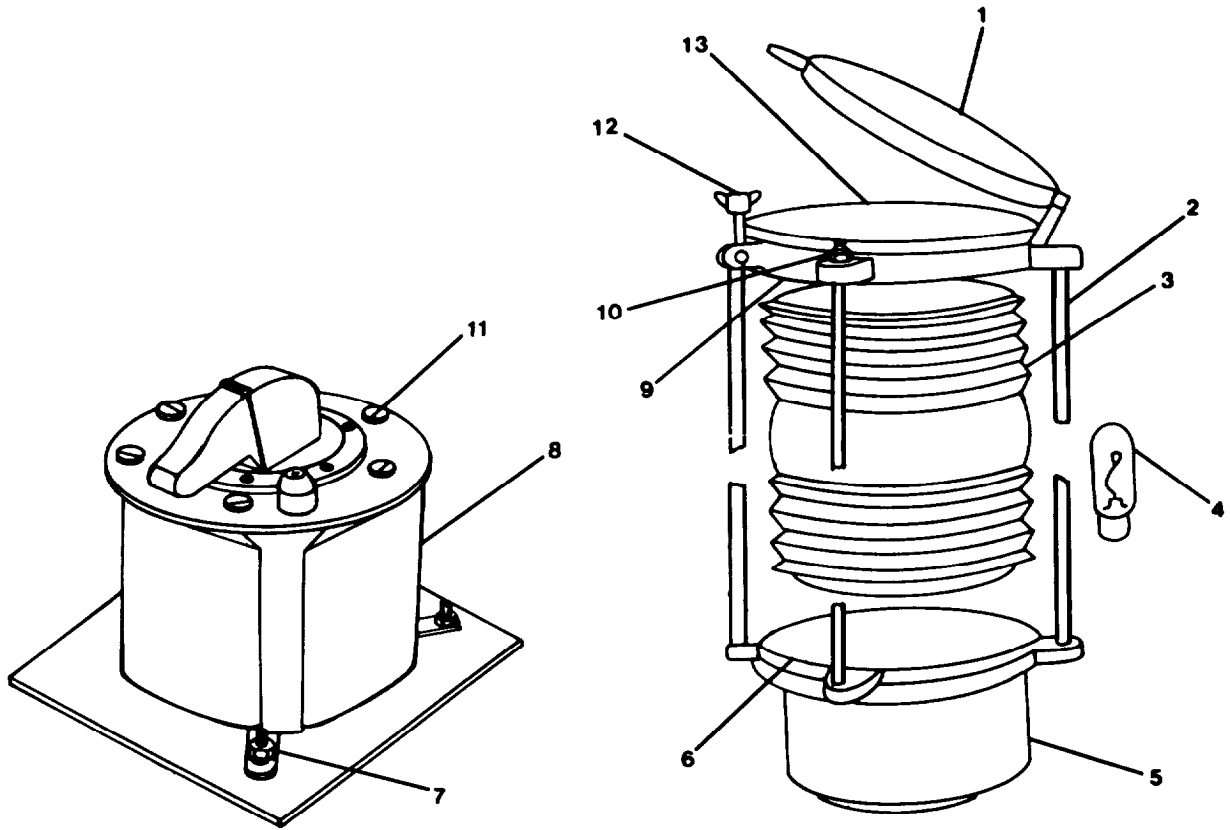
REMOVAL

- a. Unscrew blinker light base (5) from yardarm.
- b. Disconnect electrical wiring by pulling the electrical plug connector from the electrical receptacle connector at blinker light base (5).
- c. On port side of pilothouse console, remove mounting nuts (7) on navigational light control (8).
- d. Remove screws (11) and remove cover from navigational light control (8).
- e. Tag and disconnect electrical wiring.

DISASSEMBLY

- a. Loosen swivel bolt (12).
- b. Open hinged cover (1) and remove gasket (13).
- c. Push down and turn counterclockwise incandescent lamp (4) and remove.
- d. Remove hexagon nuts (10) from threaded rods (2), pull hinged cover (1) up and remove gasket (9), lens (3) and gasket (6).





9561

FIGURE 2-30. Blinker Light/Navigational Light Control.

**REPAIR**

Repair is by replacement of gasket (6, 9, and 13), lens, and incandescent lamp (4).

**ASSEMBLY**

- a. Install gasket (6) on blinker light base (5).
- b. Install lens (3), gasket (9), push cover (1) down over threaded rods (2), and tighten hexagon nuts (10).
- c. Push down and turn clockwise incandescent lamp (4) to install.
- d. Install gasket (13), close hinged cover (1), and tighten swivel bolt (12).

**REPLACEMENT**

- a. Remove tags and connect electrical wiring to navigational light control (8).
- b. Replace cover on navigational light control (8) and install screws (11).
- c. Install mounting nuts (7).
- d. Connect the blinker light electrical wiring by pushing the electrical receptacle connector and electrical plug connector together at blinker light base (5).
- e. Screw blinker light base (5) to yardarm.

---

 2-40. Repair Indicator Panel. (FIGURE 2-31)
 

---

This task covers: a. Removal, b. Repair, c. Replacement.

---



---

 INITIAL SETUP

## Materials/Parts

Cartridge fuse  
 P/N F03A25OV10AS  
 Cartridge fuse  
 P/N FO3A25OV3AS  
 Warning tag, Item 1, Appendix C

Equipment Condition

Electrical power turned OFF at emergency lighting panel EL-102 and switch tagged "Out of Service - Do Not Operate."

---

REMOVAL

- a. Apply moderate pressure to fuseholder receptacle (1) between thumb and forefinger to release fuseholder receptacle from indicator panel.
- b. Remove cartridge fuse.
- c. Turn fuse receptacle (2) counterclockwise and remove from indicator panel.
- d. Remove cartridge fuse.

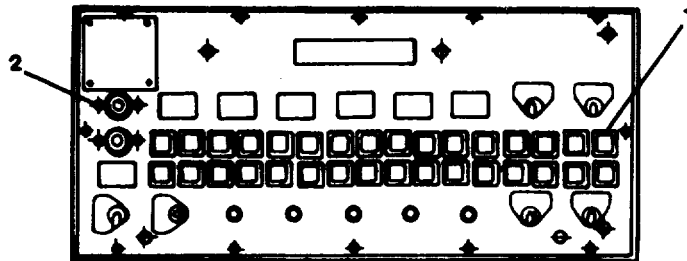


FIGURE 2-31. Indicator Panel. 9174B

REPAIR

Repair is by cartridge fuse replacement.

REPLACEMENT

- a. Install cartridge fuse in indicator panel.
- b. Install fuse receptacle (2) and turn clockwise.
- c. Install cartridge fuse in indicator panel.
- d. Apply moderate pressure to fuseholder receptacle (1) between thumb and forefinger and install in indicator panel.

2-41. Replace/Repair Indicator Panel. (FIGURE 2-32)

---

This task covers: a. Removal, b. Disassembly, c. Repair, d. Assembly,  
e. Replacement.

---

INITIAL SETUP

Tools

Tool kit, general mechanic's,  
5180-00-699-5273  
Tool kit, electrician's  
5180-00-391-1087

Equipment Condition

Electrical power turned OFF at  
Emergency Lighting Panel EL-102 and  
tagged "Out of Service - Do Not  
Operate."

Materials/Parts

Indicator light, P/N 47-3M  
Toggle switch,  
P/N MS 35059-22  
Warning tag, Item 1, Appendix C

---

REMOVAL

Remove twelve machine screws and lock washers (2).

DISASSEMBLY

- a. Tag electrical wiring (4) and remove from seven indicator lights (1).
- b. Unscrew lockrings (7) from indicator lights (1) and remove thru front of indicator panel (3).
- c. Tag electrical wiring (5) and remove from five toggle switches (8).
- d. Unscrew lockings (6) from toggle switches (8) and remove thru back of indicator panel (3).

REPAIR

Repair is by replacement of indicator lights and toggle switches.

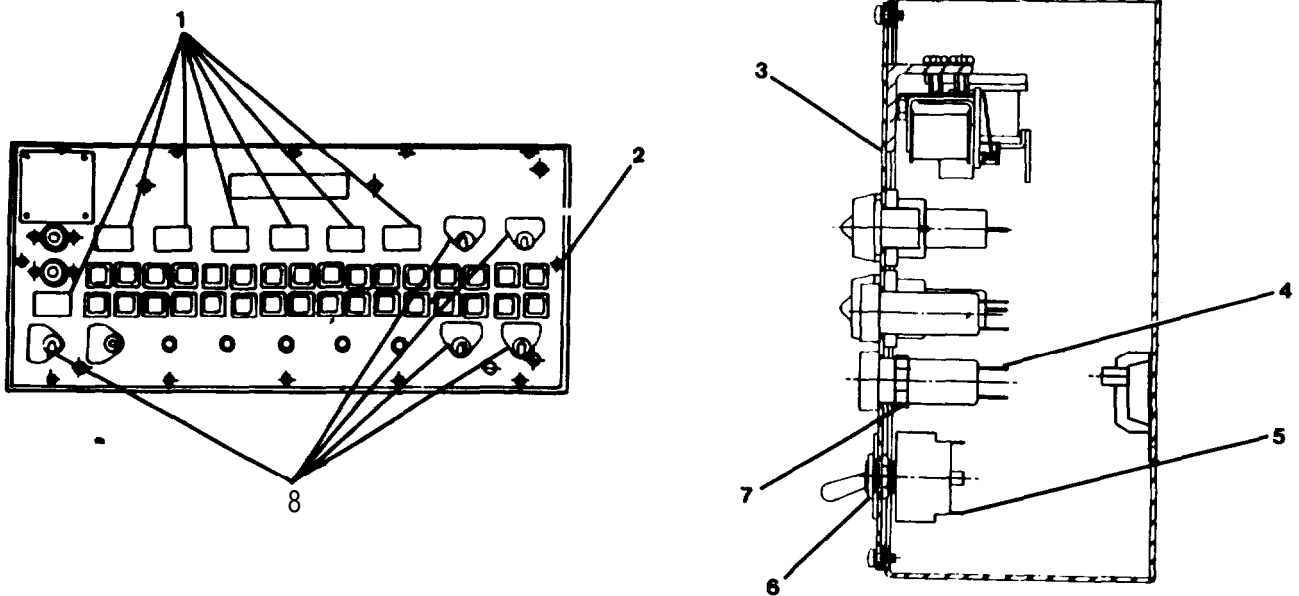
ASSEMBLY

- a. Install toggle switches (8) thru back of indicator panel (3) and secure by screwing lockrings (6) on toggle switches (8).

- b. Remove tags and connect electrical wiring (5) to toggle switches (8).
- c. Install indicator lights thru front of indicator panel (3) and secure by screwing lockrings (7) on indicator lights (1).
- d. Remove tags and connect electrical wiring (4) to indicator lights (1).

REPLACEMENT

- a. Install twelve machine screws and lock washers (2) to install front panel.
- b. Test lights.



9511

FIGURE 2-32. Indicator Panel.

2-42. Test Electrical Horn.

---

This task covers: a. Test

---

INITIAL SETUP

Tools

Tool kit, general mechanic's,  
5180-00-699-5273

Equipment Condition

Operating - TM 55-1905-223-10

---

TEST

- a. Set horn rotary switch to at-will position (3, FIGURE 2-33).

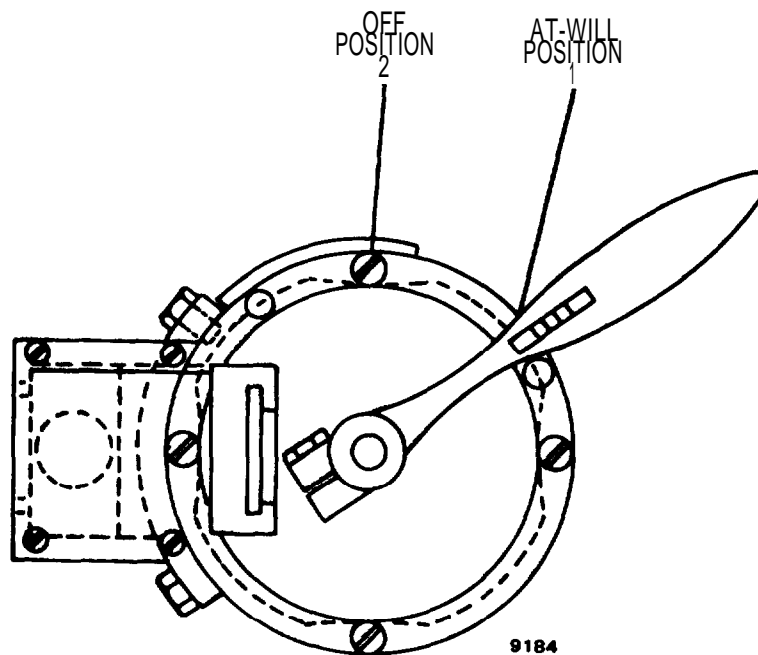


FIGURE 2-33. Electrical Horn, Test.

- b. Activate manual horn control and assure that horn responds loud and clear.  
c. Set horn rotary switch to OFF (2).  
d. Activate manual horn control and assure that horn does not operate.  
e. Set rotary switch (1, FIGURE 2-34) on sequential timer to position 1.

- f. Set horn rotary switch to AUTO position (1, FIGURE 2-34).
- g. Horn should automatically sound with the number of blasts, duration and silent intervals between blasts that corresponds to the code set in for position 1.
- h. Set rotary switch (1, FIGURE 2-34) to position 2 and compare horn response to that code set in for position 2.
- i. Set rotary switch (1, FIGURE 2-34) to position 3 and compare horn response to that code set in for position 3.
- j. While horn is operating in position 1, 2 or 3 of the AUTO mode, activate manual horn control. Manual selection should override automatic mode.
- k. Set horn rotary switch to OFF (2, FIGURE 2-33).
- l. Horn operation should stop.

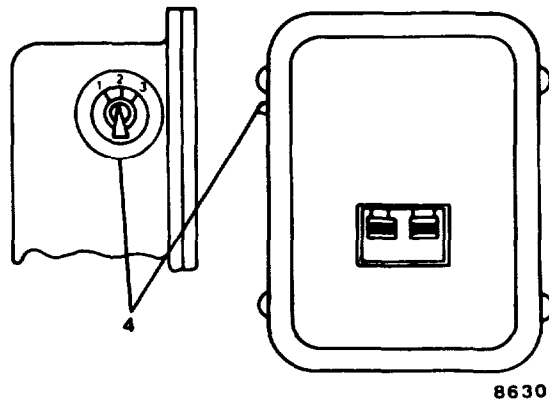


FIGURE 2-34. Timer Enclosure.

- m. Open door of sequential timer enclosure and inspect panel assembly for security of mounting, dents, bends, broken parts and security of electrical connections.
- n. If damage precludes normal operation, replace or repair as specified in paragraph 2-47 or 2-48.
- o. Inspect horn rotary switch for security of mounting, dents, bends, scratches or abrasions, broken parts and ease of operation.
- p. If damage precludes normal operation, replace rotary switch as specified in paragraph 2-49.

2-43. Replace Electrical Horn. (FIGURE 2-35)

---

This task covers: a. Removal, b. Replacement.

---

INITIAL SETUP

Tools

Tool kit, general mechanic's,  
5180-00-699-5273  
Tool kit, electrician's,  
5180-00-391-1087

Equipment Condition

Electrical power turned OFF at  
Emergency lighting panel EL-102 and  
switch tagged "Out of Service - Do  
Not Operate."

Materials/Parts

Electrical horn P/N KB-20  
Warning tags, Item 1, Appendix C

---

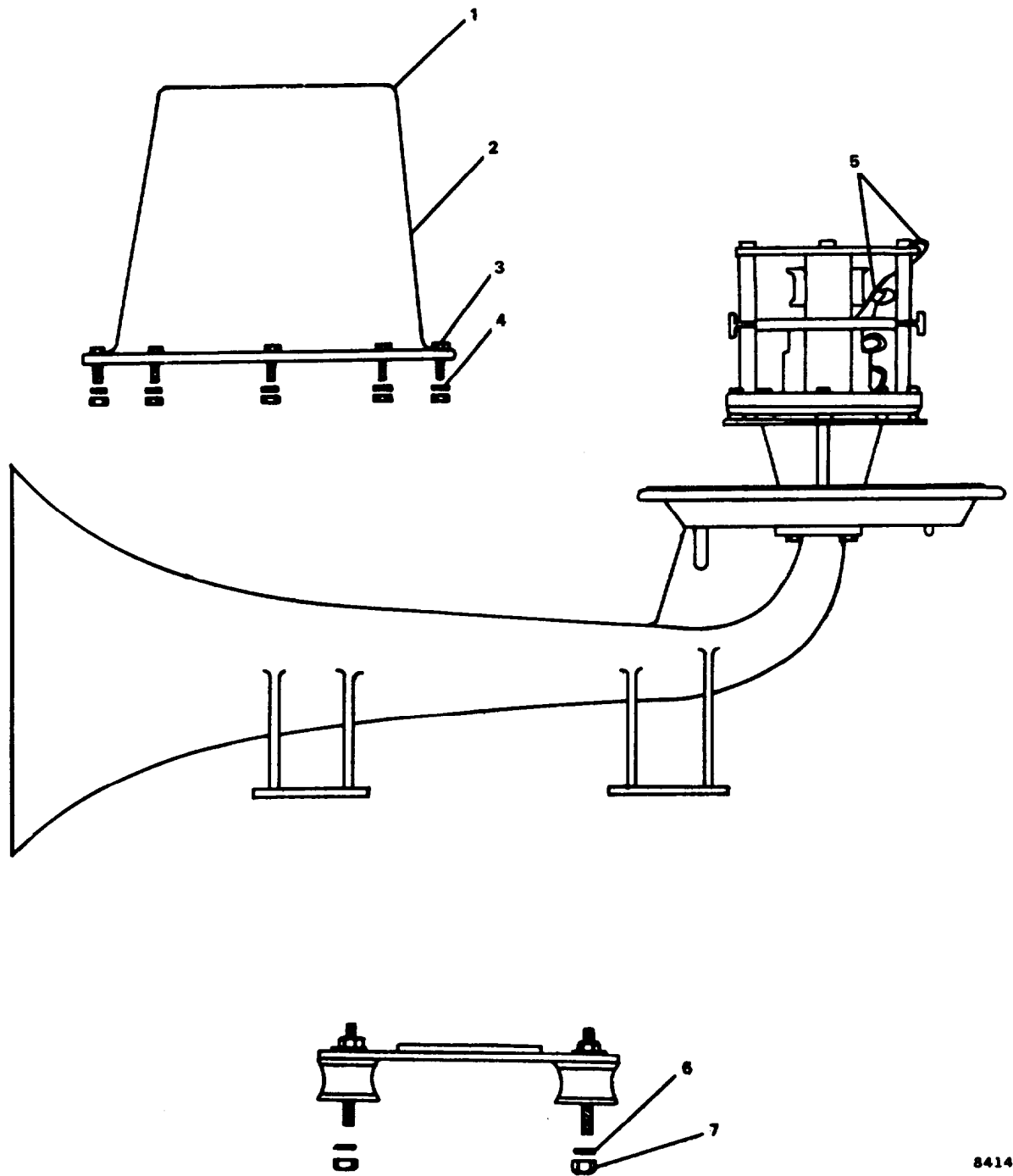
REMOVAL

- a. Remove hexagon head cap screws (2), flat washers (3), and self-locking hexagon nuts (4) holding access cover (1) in place.
- b. Remove access cover (1).
- c. Tag and disconnect electrical leads (5) to horn.
- d. Remove self-locking hexagon nuts (7) and flat washers (6).
- e. Remove electric horn.

REPLACEMENT

- a. Attach electric horn with self-locking hexagon nuts (7) and flat washers (6).
- b. Remove tags and connect electrical leads (5) to horn.
- c. Replace access cover (1) and attach with hexagon head cap screws, flat washers (3) and self-locking hexagon nuts (4).
- d. Remove tag and turn on electrical power at the emergency lighting panel.





8414

FIGURE 2-35. Electrical Horn Replace.

2-44. Repair Electrical Horn. (FIGURE 2-36)

---

This task covers: a. Disassembly, b. Repair, c. Assembly.

---

INITIAL SETUP

Tools

Tool kit, general mechanic's,  
5180-00-699-5273  
Tool kit, electrician's,  
5180-00-391-1087

Equipment Condition

Electrical power supply turned OFF,  
at emergency power panel EL-102  
and switch tagged "Out of Service -  
Do Not Operate."

Materials/Parts

Gasket P/N PT121-1  
Heater driver diaphragm PT 120-1  
Warning tags, Item 1, Appendix C

---

REMOVAL

- a. Remove hexagon head cap screws (2), flat washers (3), and self-locking hexagon nuts (4) holding access cover (1) in place.
- b. Remove access cover.
- c. Tag and disconnect electrical leads to heater driver diaphragm (5).
- d. Remove hexagon head cap screws, flat washers, and self-locking nuts (7).
- e. Remove heater drive diaphragm (5).
- f. Remove gasket (6).

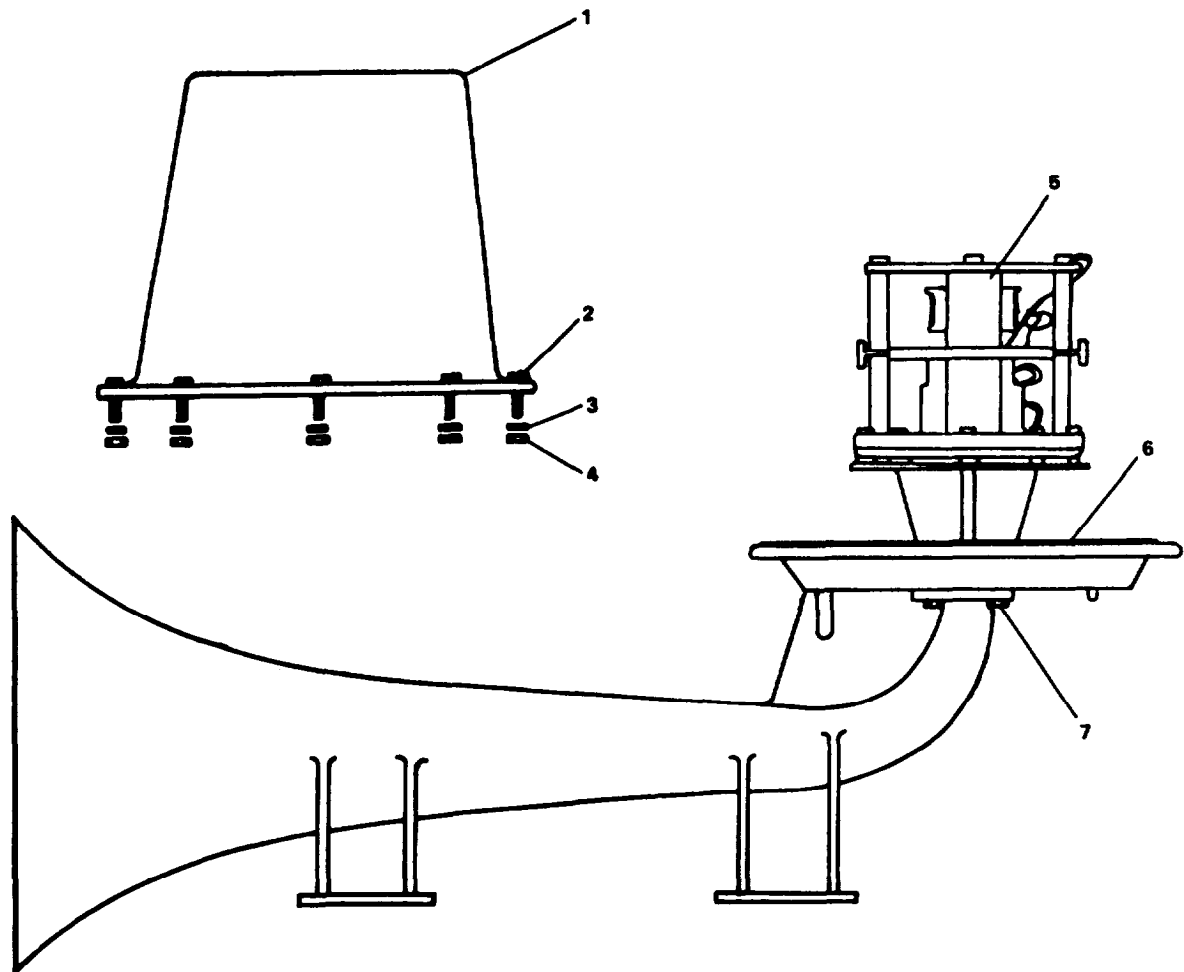
REPAIR

Repair is by replacement of heater driver diaphragm (5) and gasket (6).

REPLACEMENT

- a. Install gasket (6).
- b. Attach heater driver diaphragm (5) to horn with hexagon head cap screws flat washers and self-locking hexagon nuts (7).
- c. Remove tag and connect electrical leads to heater driver diaphragm (5).

- d. Attach access cover (1) with hexagon head capscrews (2), flat washers (3), and self-locking hexagon nuts (4).
- e. Remove tag and turn on electrical power at emergency lighting panel.
- f. Test to make sure horn works.



10362

FIGURE 2-36. Electrical Horn Repair.

2-45. Replace Power Supply. (FIGURE 2-37).

---

This task covers: a. Removal, b. Replacement.

---

INITIAL SETUP

Tools

Tool kit, general mechanic's,  
5180-00-699-5273  
Tool kit, electrician's,  
5180-00-391-1087

Equipment Condition

Electrical power turned OFF at  
emergency lighting panel EL-102  
and switch tagged "Out of Service -  
Do Not Operate."

Materials/Parts

Power supply P/N M477  
Warning tag, Item 1, Appendix C

---

REMOVAL

- a. Remove front cover (1) by removing screws (2).
- b. Tag and disconnect electrical leads from power supply.
- c. Remove screws (3) holding power supply (4) in place.
- d. Remove power supply (4).

REPLACEMENT

- a. Attach power supply (4) with screws (3).
- b. Remove tags and connect electrical leads-to terminals.
- c. Close front cover (1) and secure with screws (2).
- d. Remove tag and turn on electrical power at the emergency lighting panel.

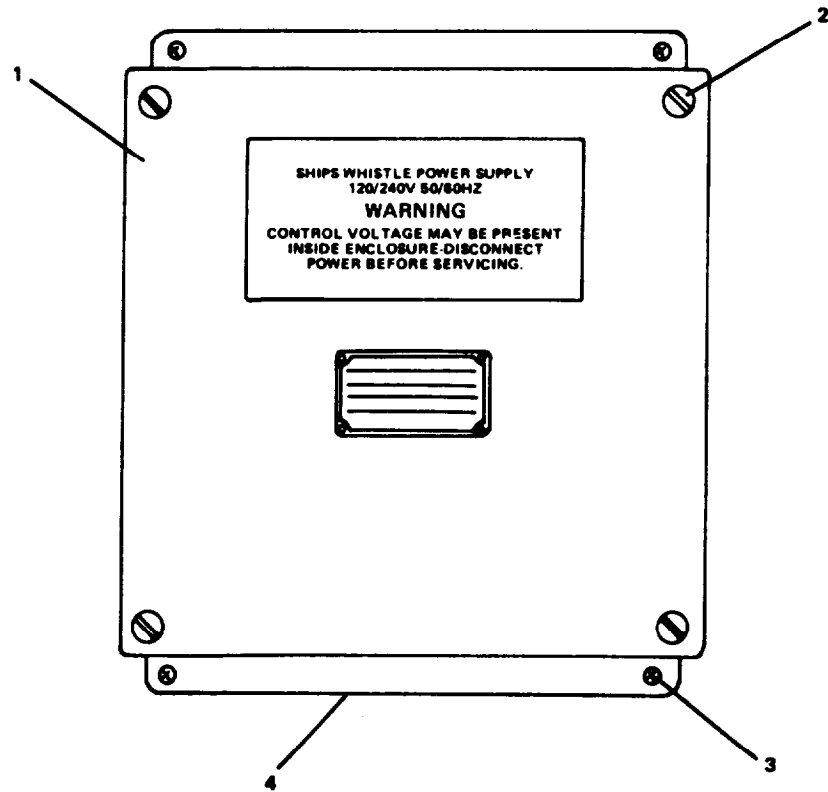


FIGURE 2-37. Power Supply. Replace.

2-46. Repair Power Supply. (FIGURE 2-38)

---

This task covers: a. Disassembly, b. Repair, c. Assembly.

---

INITIAL SETUP

Tools

Tool kit, general mechanic's,  
5180-00-699-5273  
Tool kit, electrician's,  
5180-00-391-1087

Equipment Condition

Electrical power turned OFF at  
emergency lighting panel EL-102  
and switch tagged "Out of Service -  
Do Not Operate."  
Power supply removed (para. 2-45).

Materials/Parts

Transformer P/N P490-1  
Rectifier P/N P502-1  
Capacitor P/N P500-1  
Circuit breaker (5 amp) P/N P503-1  
Circuit breaker (20 amp) P/N P503-2  
Warning tag, Item 1, Appendix C

---

DISASSEMBLY

- a. Tag and disconnect electrical leads to transformer (8) at (1, 2, 3, 4,) and (18, 19, 20, 21).
- b. Remove hexagon capscrews (7), lockwashers (6), and hexagon plain nuts (5).
- c. Remove transformer (8).
- d. Tag and disconnect electrical leads to rectifier (11).
- e. Remove machine screw (9) and lockwasher (10).
- f. Remove rectifier (11).
- g. Tag and disconnect electrical leads to capacitor (15).
- h. Remove machine screws (16) and lockwashers (17).
- i. Remove capacitor (15) from capacitor mount (14).
- j. Tag and disconnect electrical leads to two circuit breakers (12) and (13)
- k. Unscrew nut holding circuit breaker to panel side.

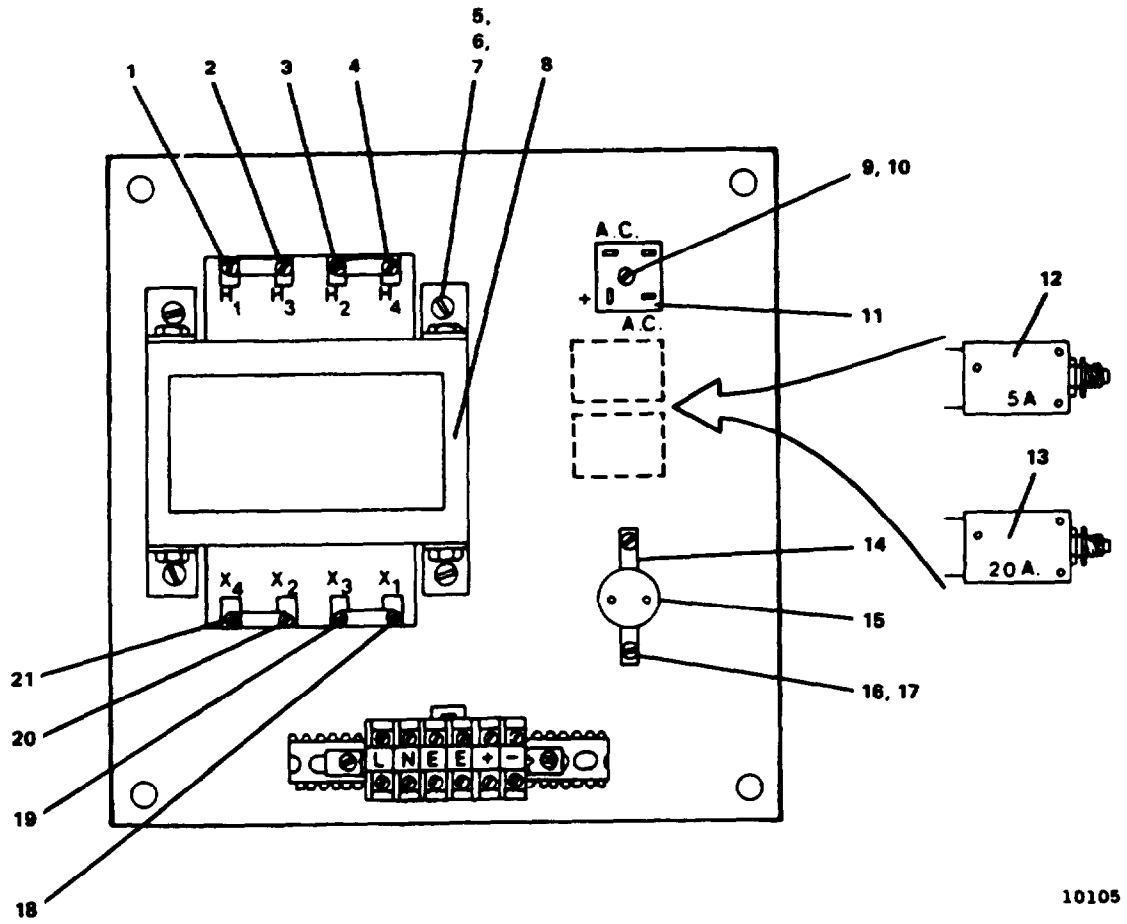
- l. Remove circuit breaker (12).
- m. Repeat step k. for second circuit breaker (13).

### REPAIR

Repair at this level of maintenance is by the replacement of: Transformer (8), rectifier (11), capacitor (15), circuit breaker (12), and circuit breaker (13).

### ASSEMBLY

- a. Position 5 amp circuit breaker (12) and push through upper hole in panel side.
- b. Hand tighten capscrew nut to hold circuit breaker (12) in place.
- c. Repeat a. and b. for 20 amp circuit breaker (13), placing it in bottom hole of panel.
- d. Remove tags and attach electrical leads to both circuit breakers (12 and 13).
- e. Position capacitor (15) in power supply and attach with machine screws (16) and lockwashers (17).
- f. Remove tags and connect electrical leads to capacitor (15).
- g. Position rectifier (11) in power supply and attach with machine screw (9) and lockwashers (10).
- h. Remove tags and connect electrical leads to rectifier (11).
- i. Position transformer (5) in power supply and attach with hexagon cap screws (4), lockwashers (3), and hexagon plain nuts (2).
- j. Remove tags and connect electrical leads to transformer at 1, 2, 3, 4, and 18, 19, 20, and 21.
- k. Attach power supply cover with screws.
- l. Replace power supply, paragraph 2-45.
- m. Remove tag and turn on electrical power at the emergency power panel EL-102.
- n. Test ship's whistle to ensure it has power.



10105

FIGURE 2-38. Power Supply, Repair.



---

## 2-47. Replace Sequential Timer. (FIGURE 2-39)

---

This task covers: a. Removal, b. Replacement.

---

### INITIAL SETUP

#### Tools

Tool kit, general mechanic's,  
5180-00-699-5273  
Tool kit, electrician's,  
5180-00-391-1087

#### Equipment Condition

Electrical power turned OFF at  
emergency lighting panel EL-102  
and switch tagged "Out of Service -  
Do Not Operate."

#### Materials/Parts

Sequential timer, M411  
Warning tags, Item 1, Appendix C

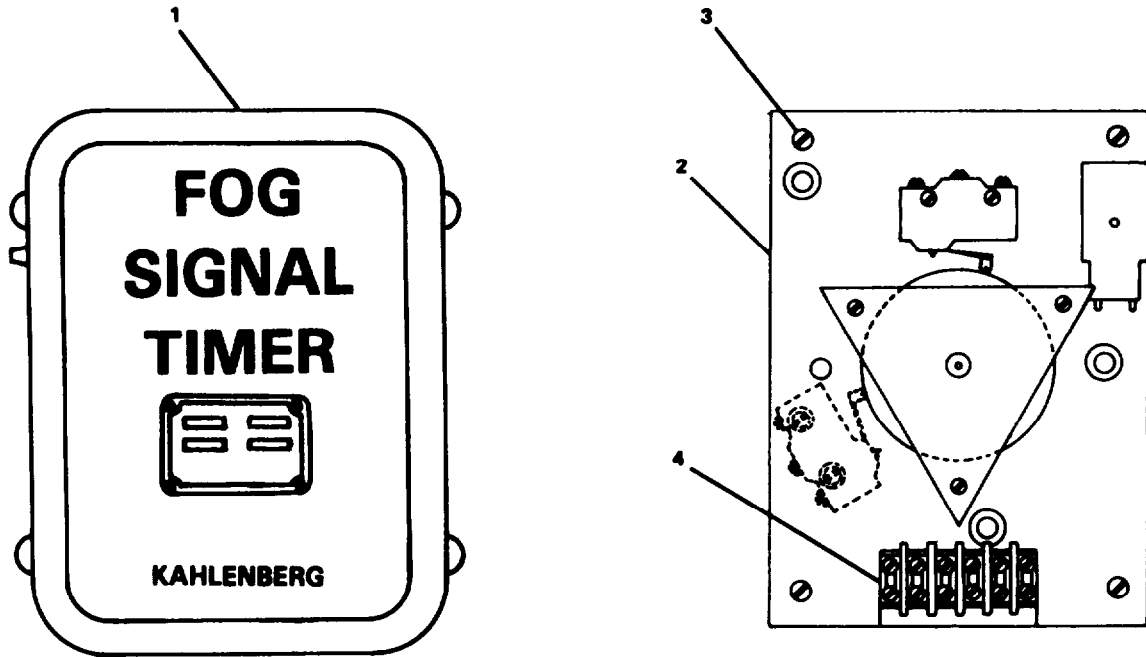
---

### REMOVAL

- a. Open front panel (1) of sequential timer (2).
- b. Tag and disconnect electrical leads from terminal board (4).
- c. Remove machine screws and lockwashers (4).
- d. Remove sequential timer.

### REPLACEMENT

- a. Position sequential timer (2) and attach with machine screws and lockwashers (4).
- b. Remove tags and connect electrical leads to terminal board (4).
- c. Close front panel (1).
- d. Remove tag and turn on electrical power at the emergency lighting panel.



10361

FIGURE 2-39. Sequential Timer.

---

**2-48. Repair Sequential Timer. (FIGURE 2-40)**

---

This task covers: a. Disassembly, b. Repair, c. Assembly.

---

**INITIAL SETUP****Tools**

Tool Kit, General Mechanic's,  
5180-00-699-5273

Tool Kit, Electrician's,  
5180-00-391-1087

**Equipment Condition**

Electrical Power Supply Turned OFF,  
at Emergency Power EL-102 and  
Switch Tagged "Out of Service  
Do Not Operate."  
Sequential Timer Removed (Paragraph 2-47).

**Materials/Parts**

Control Cam P/N P250-2  
Panel Assembly P437-4  
Rotary Switch P/N P268-1  
Motor P/N P252-12  
Switch P/N P253-5  
Alternating Current Relay P/N P254-4  
Warning Tag, Item 1, Appendix C

---

**DISASSEMBLY**

- a. Remove switch knob (8) from shaft.
- b. Remove plain hexagon nut (9).
- c. Remove switch plate (10).
- d. Remove rotary switch (11).
- e. Remove machine screws (6) and lockwashers (7).
- f. Remove motor (5).
- g. Remove machine screws (2) and lockwashers (3).
- h. Remove switch (1).
- i. Repeat step g. and h. for remaining two switches.
- j. Remove machine screws and lockwashers.
- k. Remove alternating current relay (4).

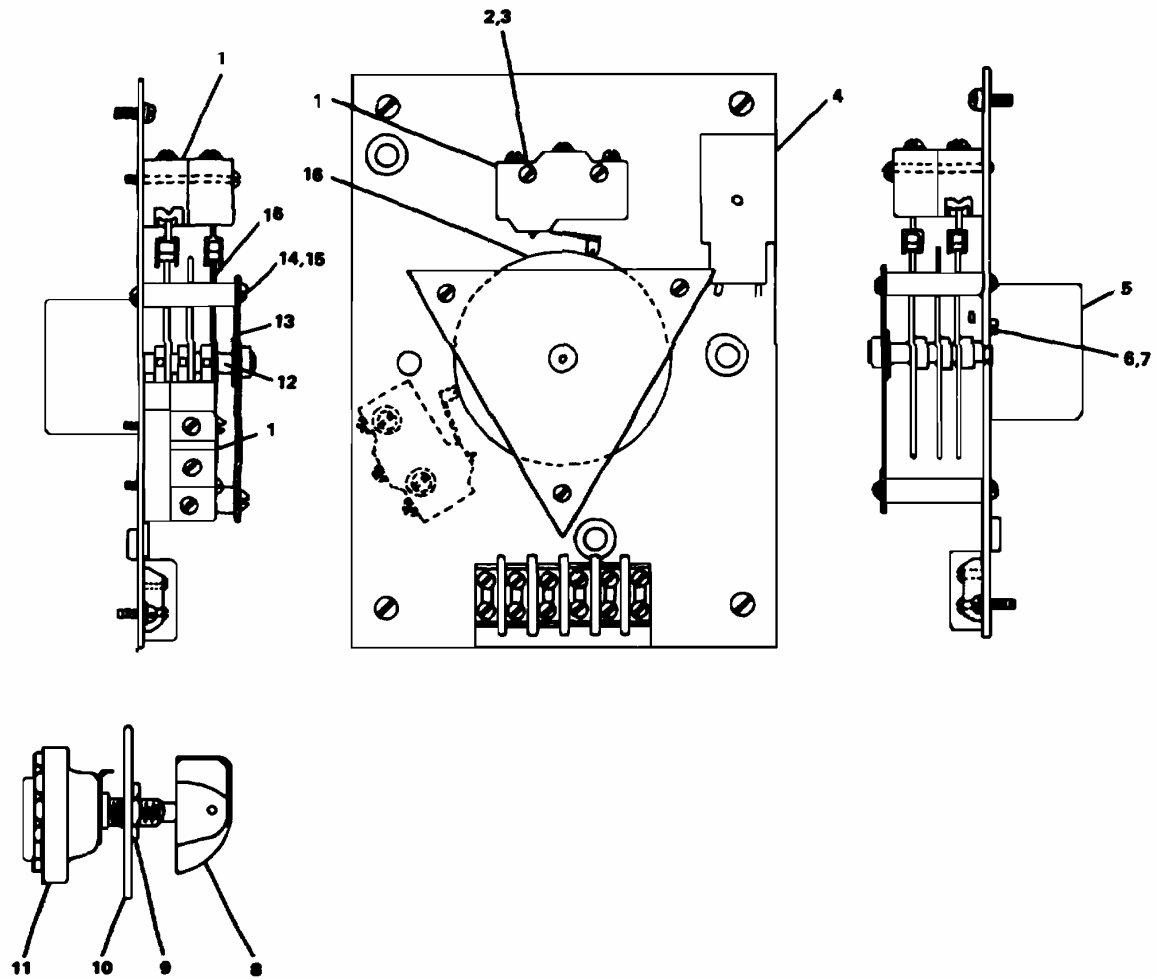


Figure 2-40. Sequential Timer, Repair.

- l. Remove machine screws (14) and lockwashers (15).
- m. Remove bracket (13) and slide control cam (16) off straight shaft (12).

### REPAIR

Repair at this level of maintenance is by replacement of: Motor (5), switch (1), rotary switch (11), control cam (16), and alternating current relay (4).

### ASSEMBLY

- a. Slide control cam (16) on straight shaft (12).
- b. Attach bracket (13) with machine screws (14) lockwashers (15).
- c. Attach alternating current relay (4) with machine screws and lockwashers.
- d. Attach switches (1) with machine screws (2) and lockwashers (3).
- e. Position motor (5) with straight shaft (12) properly positioned and engaged.
- f. Attach motor with machine screws (6) and lockwashers (7).
- g. Replace rotary switch (11) and switch plate (10).
- h. Install plain hexagon nut (9).
- i. Push switch knob (8) on shaft.
- j. Test to see if this works.

2-49. Replace/Repair Rotary Switch. (FIGURE 2-41)

---

This task covers: a. Removal, b. Disassembly, c. Repair, d. Assembly, e. Replacement.

---

**INITIAL SETUP**

**Tools**

Tool kit, general mechanic's,  
5180-00-699-5273  
Tool kit, electrician's,  
5180-00-392-2895

**Equipment Condition**

Electrical power supply turned OFF,  
at emergency power EL-102 and switch  
tagged "Out of Service - Do not  
Operate."

**Materials/Parts**

Contact kit P/N P263-1  
Gasket P/N P401-1  
Gasket P/N P402-1  
Gasket P/N P418-1  
Gasket P/N P432-1  
Preformed packing P/N  
Torsion spring P/N P353-1  
Rotary switch P/N M461  
Warning tags, Item 1, Appendix C

---

**REMOVAL**

- a. Remove machine screws (1) and cover (7) from electrical connector box (18)
- b. Tag and remove electrical leads.
- c. Remove mounting screws (2).
- d. Remove rotary switch (20).

**DISASSEMBLY**

- a. Loosen hexagon capscrew (6).
- b. Squeeze lever switch (4) and remove switch handle (3) from shaft.
- c. Remove machine screws (2) and remove cover (8) from housing (11).
- d. Remove plain hexagon nut (15) and adjusting screw (16).
- e. Remove machine screws (14) and remove cover (17).

**REPAIR**

Repair at this level of maintenance is by replacement of: Gaskets (5, 10, 13, and 19), preformed packing (9) and spiral torsion spring (12). Contact kit needed for repair of rotary switch.

**ASSEMBLY**

- a. Attach cover (17) on housing (11) with machine screws (14).
- b. Install adjusting screw (16) and plain hexagon nut (15).
- c. Attach cover (8) with machine screws (2).
- d. Squeeze lever switch (4) and install switch handle (3) on shaft.
- e. Tighten hexagon capscrew (6).

**REPLACEMENT**

- a. Attach rotary switch with mounting screws.
- b. Thread electrical leads through hole in bottom of electrical connector box (18).
- c. Remove tags and connect electrical leads.
- d. Replace cover (7) with machine screws (1) on electrical connector box.
- e. Remove tag and turn on electrical power at the emergency lighting panel.
- f. Test horn.

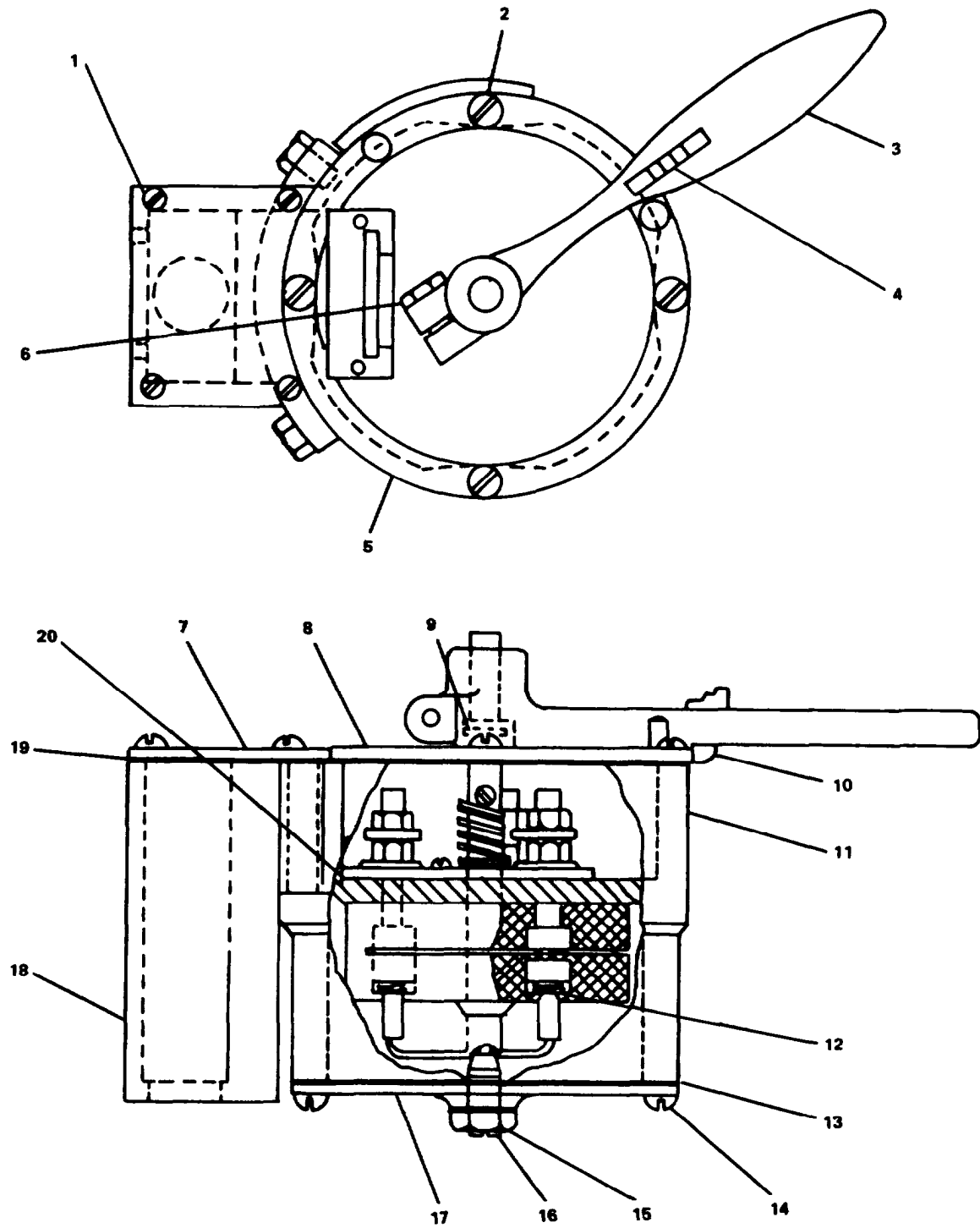


FIGURE 2-41. Rotary Switch.



---

**2-50. Replace Oscillator Unit. (FIGURE 2-42)**

---

This task covers: a. Removal, b. Repair, c. Replacement.

---

**INITIAL SETUP****Tools**

Tool kit, general mechanic's,  
5180-00-699-5273  
Tool kit, electrician's,  
5180-00-391-1087

**Equipment Condition**

Electrical power supply turned OFF,  
at emergency lighting panel EL-102  
and switch tagged "Out of Service -  
Do not Operate."

**Materials/Parts**

Oscillator P/N M-478  
Warning tags, Item 1, Appendix C

---

**REMOVAL**

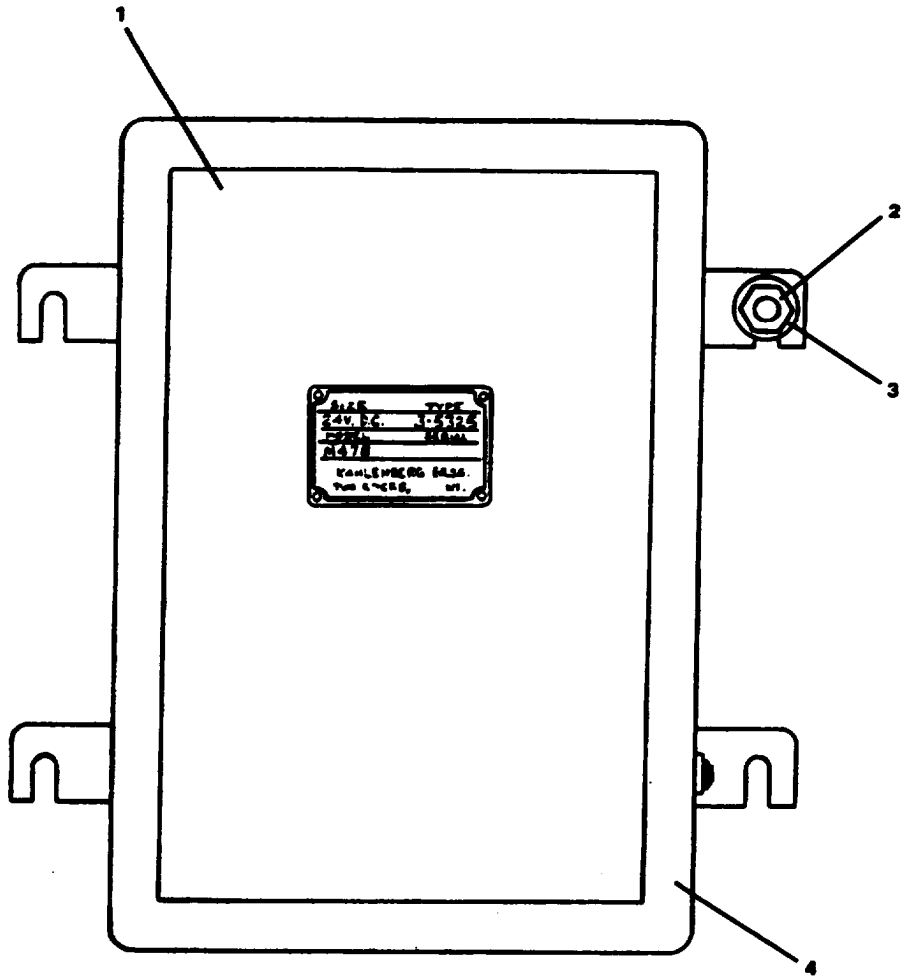
- a. Open front cover (1).
- b. Tag and disconnect electrical leads (inside unit) from oscillator unit.
- c. Remove nuts (2) and washers (3) holding oscillator unit in place.
- d. Remove oscillator unit (4) from bracket.

**REPAIR**

Repair at this level of maintenance is by replacement of: Oscillator unit.

**REPLACEMENT**

- a. Attach oscillator unit (4) to bracket with nuts (2) and washers (3).
- b. Remove tags and connect electrical lead(s).
- c. Close front cover (1).
- d. Remove tag and turn on electrical power at the emergency lighting panel.



10103

FIGURE 2-42. Oscillator Unit.

MAINTENANCE OF MACHINERY SHOP EQUIPMENT
---

---

2-51. Replace/Repair Arc Welding Machine. (FIGURE 2-43)

---

This task covers: a. Removal, b. Repair, c. Replacement.

---

### INITIAL SETUP

#### Tools

Tool kit, general mechanic's,  
5180-00-699-5273  
Tool kit, electrician's,  
5180-00-391-1087  
Lifting sling P/N 3375958

#### Equipment Condition

Electrical power to unit OFF at the ship's service switchboard. Switch tagged "Out of Service - Do Not Operate."

#### Materials/Parts

Arc welding machine  
P/N 1341-0354  
Warning tags, Item 1, Appendix C

---

### REMOVAL

- a. Close water and gas valves.
- b. Disconnect water, and gas connections (3).
- c. Remove power cable from bulkhead terminal box.
- d. Disconnect welding leads (1).
- e. Remove deck mounting nuts (2) from the arc welding machine frame.

#### CAUTION

The arc welding machine weighs in excess of 50 lb. It will require a lifting sling and dolly to move.

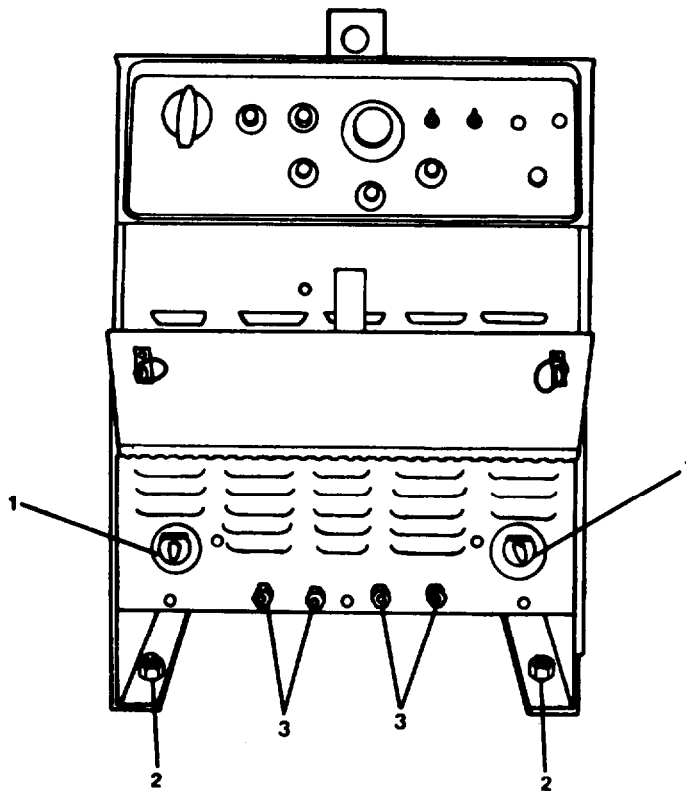
- f. Remove arc welding machine.

### REPAIR

Repair at this level of maintenance is by replacement of arc welding machine.

**REPLACEMENT**

- a. Install arc welding machine onto deck mounted studs.
- b. Install and tighten nuts (2). torque to 100 ft-lbs (135.6 N•m).
- c. Connect welding leads (1).
- d. Install power cable from bulkhead terminal box.
- e. Connect water and gas connections (3).
- f. Open water and gas valves.
- g. Remove tag and turn on electrical power at the ships service switchboard.



8889

FIGURE 2-43. Arc Welder.

---

## 2-52. Replace/Repair Remote Foot Control. (FIGURE 2-44)

---

This task covers: a. Removal, b. Repair, c. Replacement.

---

### INITIAL SETUP

#### Tools

Tool kit, general mechanic's,  
5180-00-699-5273  
Tool kit, electrician's,  
5180-00-391-1087

#### Equipment Condition

Electrical power to unit OFF at ship's  
service switchboard, and switch  
tagged "Out of Service - Do Not  
Operate."

### Materials/Parts

Remote foot control  
P/N 1388-0043  
Warning tags, Item 1, Appendix C

---

### REMOVAL

Remove remote foot control by pulling cable plug (6) from receptacle on welding machine.

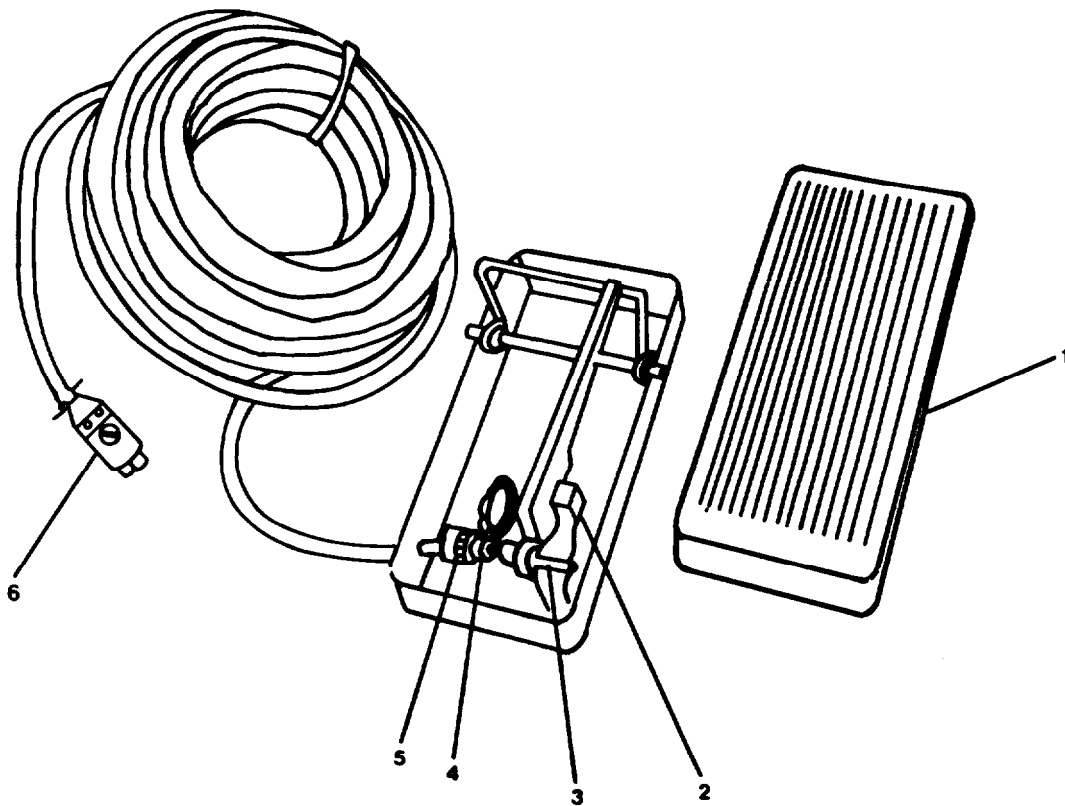
### REPAIR

- a. Remove cover (1) by pulling upward.
- b. Loosen small nut (4) at potentiometer (5) and pull switch/lever shaft (3) from remote foot control bottom.
- c. Remove nuts (4) holding potentiometer and remove potentiometer.
- d. Disconnect wire leads and replace potentiometer.
- e. Remove bottom nuts and screws holding switch (3) and remove and replace switch.
- f. Place switch (3) in foot control bottom and tighten nuts and screws.
- g. Connect wire leads to potentiometer.
- h. Place potentiometer (5) on switch/lever shaft (3). Do not tighten nut (4).
- i. Place potentiometer - shaft assembly into bracket and tighten mounting nut (4).

j. Install cover (1).

**REPLACEMENT**

Plug remote control cable plug (6) into receptacle on front of welding machine.



8888

FIGURE 2-44. Welder Foot Control.

---

**2-53. Repair Electronic Module Assembly. (FIGURE 2-45)**

---

This task covers: a. Removal, b. Repair, c. Replacement.

---

**INITIAL SETUP****Materials/Parts**

Cartridge fuse P/N 0828-2395  
Warning tags, Item 1, Appendix C

**Equipment Condition**

Electrical power to unit OFF at ship's  
service switchboard. Switch tagged  
"Out of Service - Do Not Operate."

---

**REMOVAL**

- a. Remove fuse cap (1).
- b. Remove cartridge fuse (2).

FIGURE 2-45. Repair Electronic Module Assembly.

**REPAIR**

Repair at this level of maintenance is by replacement of: Cartridge fuse (2).

**REPLACEMENT**

- a. Install cartridge fuse (2).
- b. Install fuse cap (1).
- c. Remove tag and turn ON electrical power at ship's service switchboard.

MAINTENANCE OF COMMISSARY EQUIPMENT
-------------------------------------

---

2-54. Replace/Repair Electric Range Assembly. (FIGURE 2-46)

---

This task covers: a. Removal, b. Repair, c. Replacement.

---

INITIAL SETUP

Tools

Tool kit, general mechanic's,  
5180-00-699-5273  
Tool kit, electrician's,  
5180-00-391-1087

Equipment Condition

Electrical power turned OFF at galley 240V power panel. Switch tagged "Out of Service - Do Not Operate."

Materials/Parts

Electrical range assembly  
P/N MR36D2  
Electrical nonimmersion heating elements P/N 20B2E-6, 20B2E-8, 20M1E-2, and 20M1E-6  
Warning tags, Item 1, Appendix C

---

REMOVAL

- a. Tag and disconnect electrical leads.
- b. Removal of twin panel round hot plate includes:
  - (1) Lift up at rim of solid surface unit (1, Sheet 1) from twin panel plate (2), turn over, and lay down on its top.
  - (2) Tag and remove wires from hot plate element and remove assembly.
  - (3) Remove hex capscrew (3).
  - (4) Remove element clamp plate (4) and spider clamp (5).
  - (5) Remove inner heat element (6) and outer heat element (7).
  - (6) Remove machine screw (8) from solid round surface ring (9).
  - (7) Remove solid round surface ring from solid round casting (10).



c. Removal of the rectangular hot plate includes:

- (1) Lift adjoining electric range top plates (11, Sheet 2) together at front of range and prop up in a convenient position.
- (2) Tag and remove wires from hot plate elements (13 and 14).
- (3) Remove four hex nuts (17) and washers (19) holding element shield (20).
- (4) Remove element shield.
- (5) Remove four hex nuts (17) holding element baffle (21).
- (6) Remove element baffle.
- (7) Remove four hex nuts (17), six capscrews (18), stud (16) and large washers (15) holding element clamp plate (22) in place.
- (8) Remove clamp plate and heating elements (13 and 14).

NOTE

Ensure clamping surface is flat and clean, and the clamp plate is not warped.

NOTE

Hot plates can be separated by removing hex capscrew (23) from front and back edge of adjoining hot plates and unlatching latch (24). Then, pry hot plates apart exposing the key strip (12). Each plate can be turned over individually.

d. Remove mounting bolts and electric range assembly, if necessary.

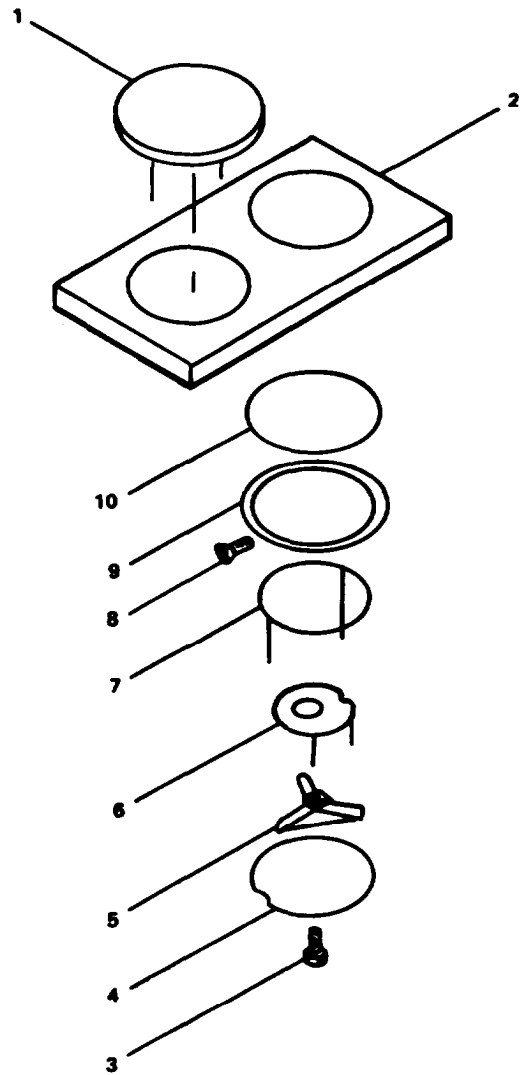
### **REPAIR**

Repair at this level of maintenance is by replacement of electrical nonimmersion heating elements (6 and 7, Sheet 1; and 13 and 14, Sheet 2).

### **REPLACEMENT**

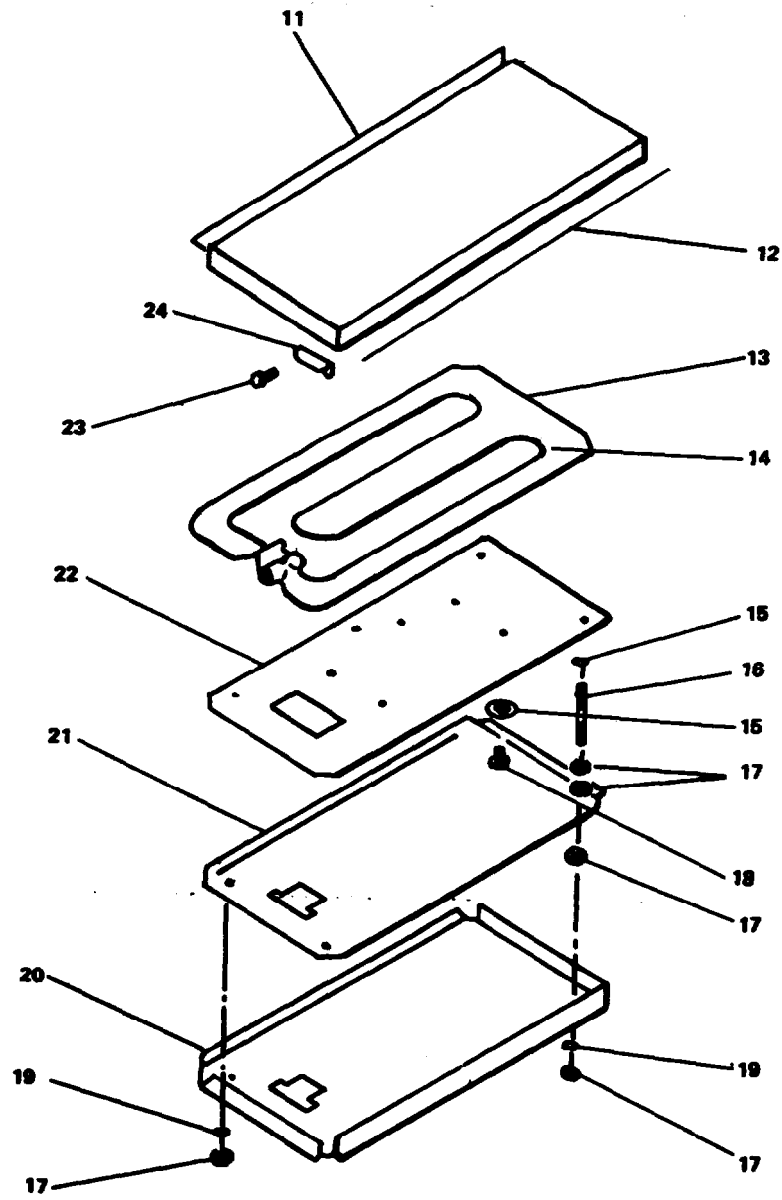
a. Replacement of twin panel round hot plate includes:

- (1) Insert solid round casting (10, Sheet 1) into solid round surface ring (9).
- (2) Insert machine screw (8).
- (3) Insert outer heat element (7) and inner heat element (6).
- (4) Insert spider clamp (5) and element clamp plate (4).



10306

FIGURE 2-46. Electric Range Assembly (Sheet 1 of 2).



10307

FIGURE 2-46. Electric Range Assembly (Sheet 2 of 2).

- (5) Insert hex capscrew (3).
- (6) Remove tags and connect electrical leads to solid surface unit (1).
- (7) Insert solid surface unit in twin panel assembly (2).

b. Replacement of rectangular hot plate includes:

NOTE

If adjoining hot plates were separated in removal, be sure to thoroughly clean carbon and grease from key strip (12, Sheet 2) area and edges between the plates for proper fit.

- (1) Insert six capscrews (18) and large washers (15) holding heating elements (13 and 14) to element clamp plate (22).
- (2) Insert clamp plate on top plate (11) corner studs (17) with four hex nuts (17) and large washers (15).
- (3) Insert element baffle (21) with four hex nuts (17).
- (4) Insert element shield (20) with four hex nuts (17) and washers (19).
- (5) Remove tags and connect electrical leads to heating elements (13 and 14).

NOTE

If adjoining hot plates were separated in removal, fit plates together at key strip (12). Align latches (24) at front and back edge and insert hex capscrew (23) to secure hot plates.

- (6) If hot plates propped up for removal, remove prop and lower adjoining top plates (11).

- c. Install electric range assembly and mounting bolts, if removed.
- d. Remove tags and connect electrical leads.

---

## 2-55. Replace Self-Heating Griddle.

---

This task covers: a. Removal, b. Replacement.

---

### INITIAL SETUP

#### Tools

Tool kit, general mechanic's,  
5180-00-699-5273  
Tool kit, electrician's,  
5180-00-391-1087

#### Equipment Condition

Electrical power turned OFF at galley  
240V power panel. Switch tagged "Out  
of Service - Do Not Operate."

#### Materials/Parts

Self-heating griddle P/N 7224  
Warning tags, Item 1, Appendix C

---

### REMOVAL

- a. Tag and disconnect electrical leads.
- b. Remove self-heating griddle.

### REPLACEMENT

- a. Install self-heating griddle.
- b. Make sure all controls are in OFF position.
- c. Turn on electrical power at galley 240V power panel and remove tags.

---

2-56. Replace/Repair Electric Food Mixing Machine. (FIGURE 2-47)

---

This task covers: a. Removal, b. Repair, c. Replacement.

---

**INITIAL SETUP**

**Tools**

Tool kit, general mechanic's,  
5180-00-699-5273

Food mixing machine off.

**Materials/Parts**

Electric food mixing machine  
P/N Model BZOT.

---

**REMOVAL**

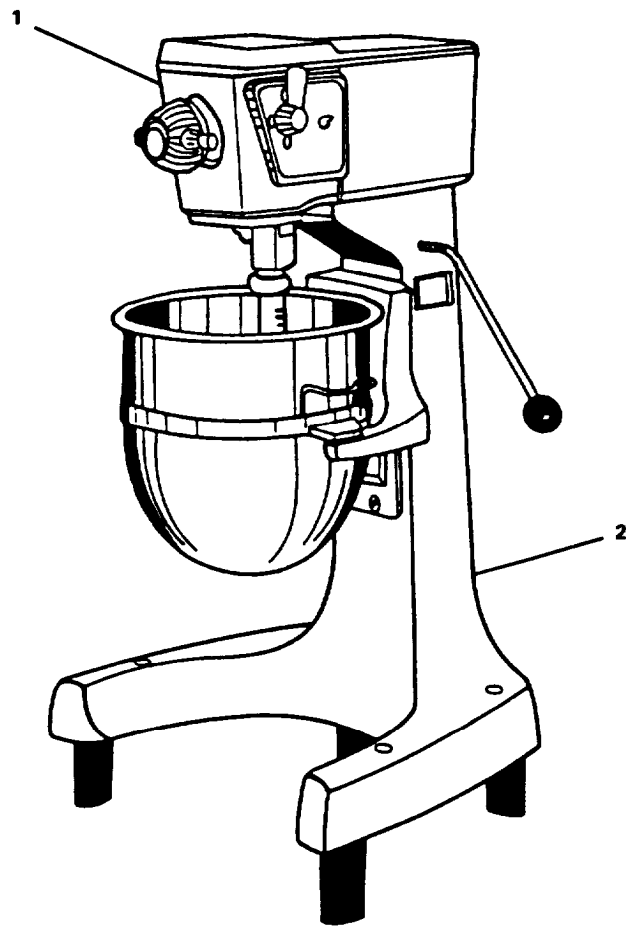
- a. Unplug mixer power cord from electrical receptacle.
- b. Remove mounting bolts.
- c. Remove electric food mixing machine.

**REPAIR**

Repair at this level of maintenance is by replacement of electric food mixing machine, mechanical transmission (1), transmission internal components, or the column and base assembly (2). Refer to paragraphs 2-57 through 2-59.

**REPLACEMENT**

- a. Install electric food mixing machine.
- b. Install mounting bolts.
- c. Assure all controls are in OFF position.
- d. Plug mixer power cord into electrical receptacle.



10308

FIGURE 2-47. Electric Food Mixing Machine.

2-57. Replace/Repair Mechanical Transmission. (FIGURE 2-48)

---

This task covers: a. Removal, b. Repair, c. Replacement.

---

**INITIAL SETUP**

**Tools**

Tool kit, general mechanic's,  
5180-00-699-5273

**Equipment Condition**

Electric food mixing machine,  
removed, para. 2-56.

**Materials/Parts**

Mechanical transmission, P/N M5-330-D

---

**REMOVAL**

- a. Remove drain plug (12) and drain transmission.
- b. Remove plug (6), retaining ring (7), and manual control level (8).
- c. Remove machine screw (11) and identification plate (10).
- d. Tag and disconnect electrical leads from stop timer (9).
- e. Remove stop timer.
- f. Remove machine screw (1) and top cover (2).
- g. Remove machine screw (4) and cover plate (5).
- h. Remove nut (14) and motor housing (3).
- i. Remove socket capscrew (15) and alternating current motor (16).
- j. Separate motor and mechanical transmission (13).

**REPAIR**

Repair at this level of maintenance is by replacement of mechanical transmission (13) or internal components. Refer to paragraph 2-58 for internal components replacement.



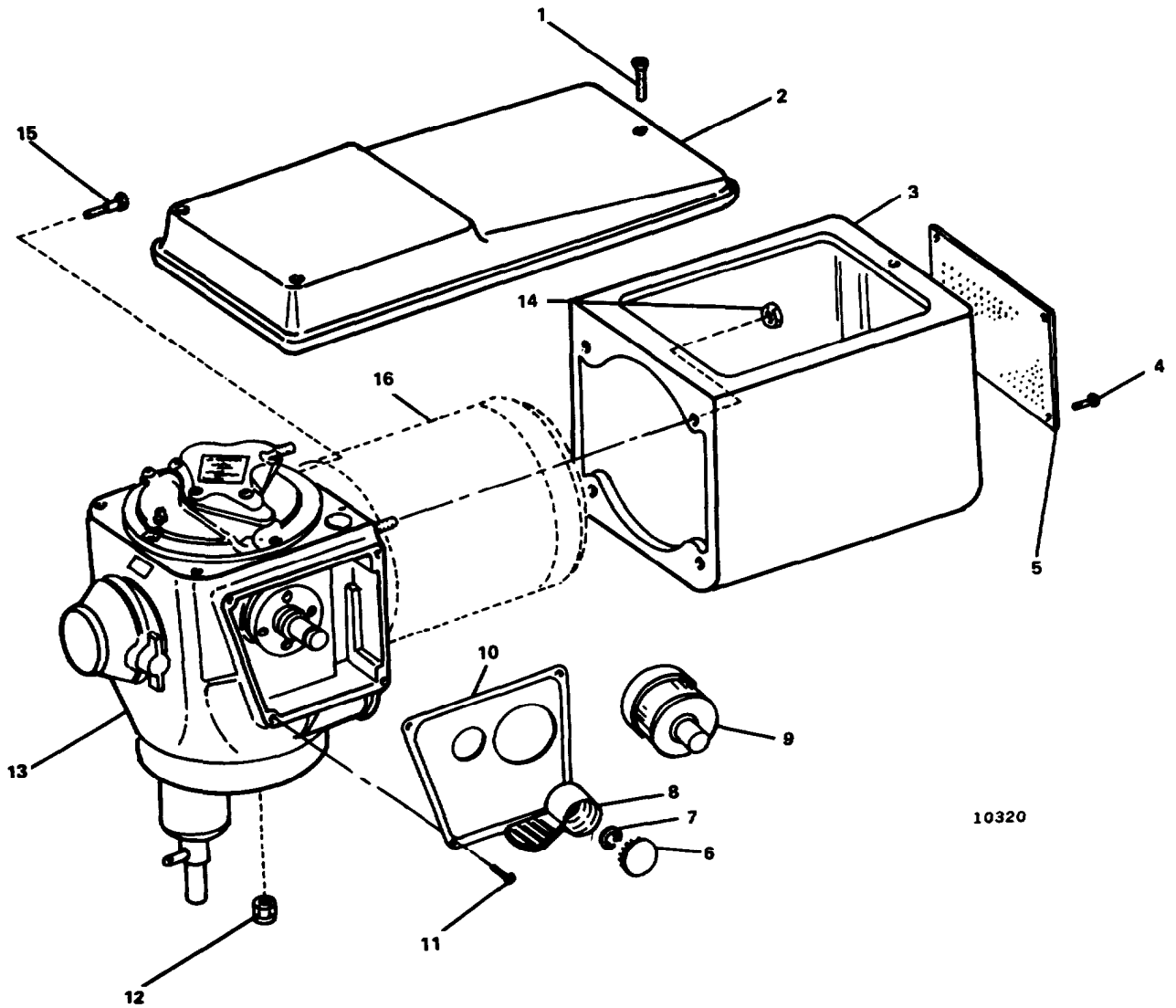


FIGURE 2-48. Mechanical Transmission and Motor Housing.

REPLACEMENT

- a. Install motor (16) on transmission (13) and attach with capscrews (15).
- b. Install motor housing (3) and attach with nut (14).
- c. Install cover plate (5) and attach with machine screw (4).
- d. Install top cover (2) and attach with machine screw (1).
- e. Install stop timer (9).
- f. Remove tags and connect electrical leads.
- g. Install identification plate (10) and attach with machine screw (11).
- h. Install manual control level (8), retaining ring (7), and plug (6).
- i. Install drain plug (12).

---

**2-58. Replace Mechanical Transmission Internal Components. (FIGURE 2-49)**

---

This task covers: a. Removal, b. Replacement

---

**INITIAL SETUP****Tools**

Tool kit, general mechanic's,  
5180-00-699-5273

**Equipment Condition**

Alternating current motor and  
transmission removed, para. 2-57.

**Materials/Parts**

Intermediate shaft assembly  
P/N WO-14682  
Shifter yoke assembly P/N M2-3345-B

---

**REMOVAL**

- a. Remove machine screws (15), and washers (14).

NOTE

Gears may have to be rotated to clear transmission housing assembly.

- b. Remove cover (12). Rotate gears as required.
- c. Remove machine screws (2), washers (1), and shaft cover (3) to gain access to shaft retaining rings (4, 5, and 13).
- d. Remove retaining ring (4) on end of sun shaft group (10) and remove sun shaft.
- e. Remove retaining ring (5) on end of pinion shaft group (6) and remove pinion shaft.
- f. Remove retaining ring (13) on end of intermediate shaft assembly (11) and remove shaft assembly.
- g. Remove rod (8) and shifter yoke assembly (7).
- h. Remove rod from shifter yoke assembly.

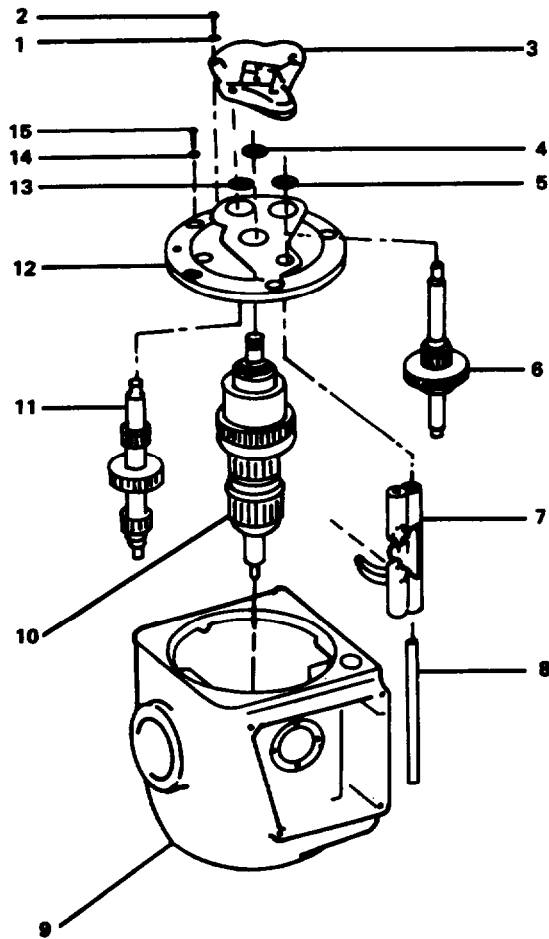


FIGURE 2-49. Electrical Food Mechanical Transmission.

REPLACEMENT

- a. Install end of intermediate shaft assembly (11) into cover (12) and attach retaining ring (13).
- b. Install end of pinion shaft group (6) into cover (12) and attach retaining ring (5).
- c. Install end of sun shaft group (10) into cover (12) and attach retaining ring (4).
- d. Install rod (8) into shifter yoke assembly (7).
- e. Install rod and yoke assembly into cover (12).
- f. Install cover (12) with units installed into mechanical transmission (9).
- g. Install lockwasher (14) and machine screw (15) into cover (12).
- h. Install shaft cover (3) on cover (12) with machine screws (2) and washers (1).

## NOTE

Gears may have to be rotated to clear transmission housing assembly.

- i. Refer to paragraph 2-57 to install mechanical transmission.

2-59. Replace Column and Base Assembly. (FIGURE 2-50)

---

This task covers: a. Removal, b. Replacement.

---

**INITIAL SETUP**

**Tools**

Tool kit, general mechanic's,  
5180-00-699-5273

**Equipment Condition**

Motor and transmission removed,  
para. 2-57.

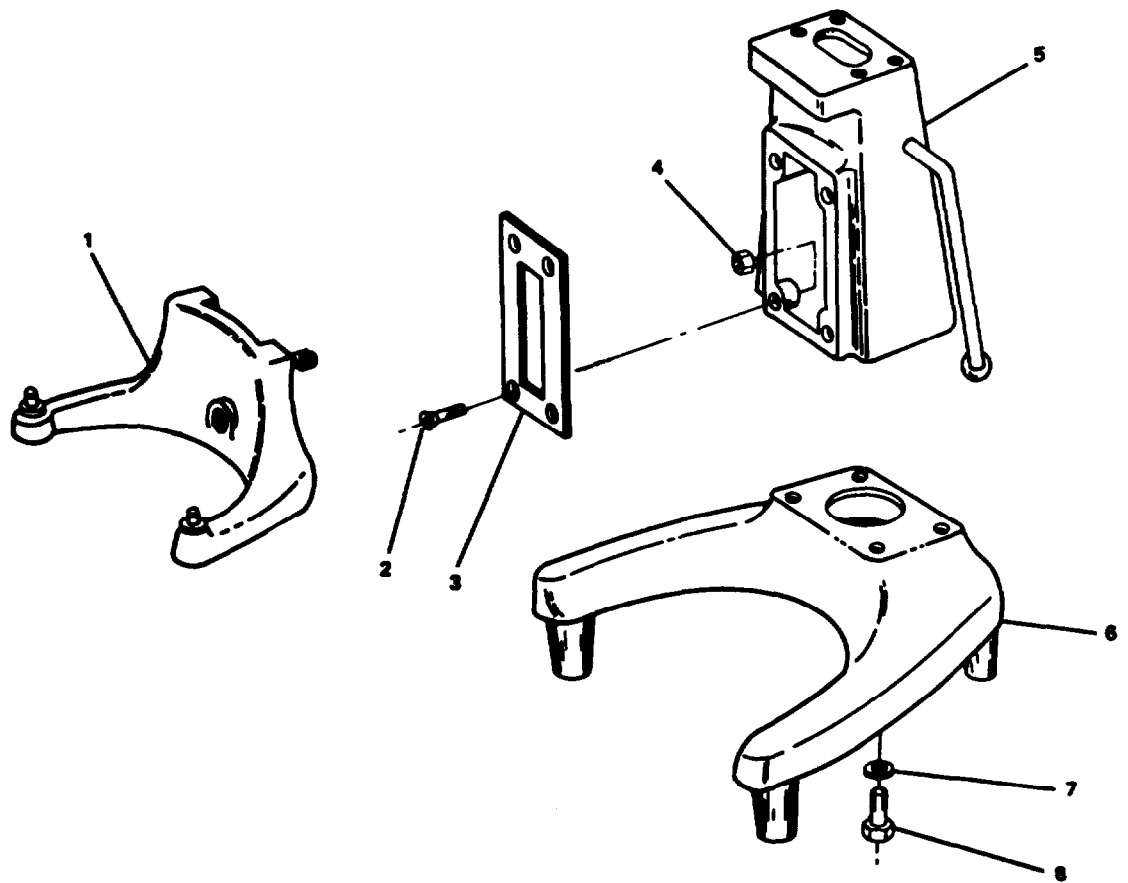
---

**REMOVAL**

- a. Remove bowl support (1).
- b. Remove machine screws (2), nuts (4), and bowl support bar (3).
- c. Remove hexagon capscrews (8) and lockwashers (7).
- d. Remove column (5) from base (6).

**REPLACEMENT**

- a. Install column (5) on base (6) and attach with hexagon capscrews (8) and lockwashers (7).
- b. Install bowl support bar (3) and attach with machine screws (2) and nuts (4).
- c. Install bowl support (1).
- d. Replace motor and transmission; refer to paragraph 2-57.



10316

FIGURE 2-50. Repair Column Base Assembly.

2-60. Replace/Repair Electric Meat Slicing Machine. (FIGURE 2-51)

---

This task covers: a. Removal, b. Repair, c. Replacement.

---

INITIAL SETUP

Tools

Tool kit, general mechanic's,  
5180-00-699-5273  
Tool kit, electrician's,  
5180-00-391-1087

Equipment Condition

Meat slicing machine off.

Materials/Parts

Electric meat slicing machine  
P/N Model 512

---

WARNING

Care must be taken when working around  
knife. It is razor sharp.

REMOVAL

- a. Unplug slicer electrical cord from electrical receptacle.
- b. Turn slice adjusting knob (1) clockwise as far as it will go.
- c. Remove electric meat slicing machine.

REPAIR

Repair at this level of maintenance is by replacement of electric meat slicing machine components. Refer to paragraph 2-61 through 2-67.

REPLACEMENT

- a. Replace electric meat slicing machine.
- b. Make sure slicer power switch is OFF.
- c. Plug slicer electrical cord into electrical receptacle.



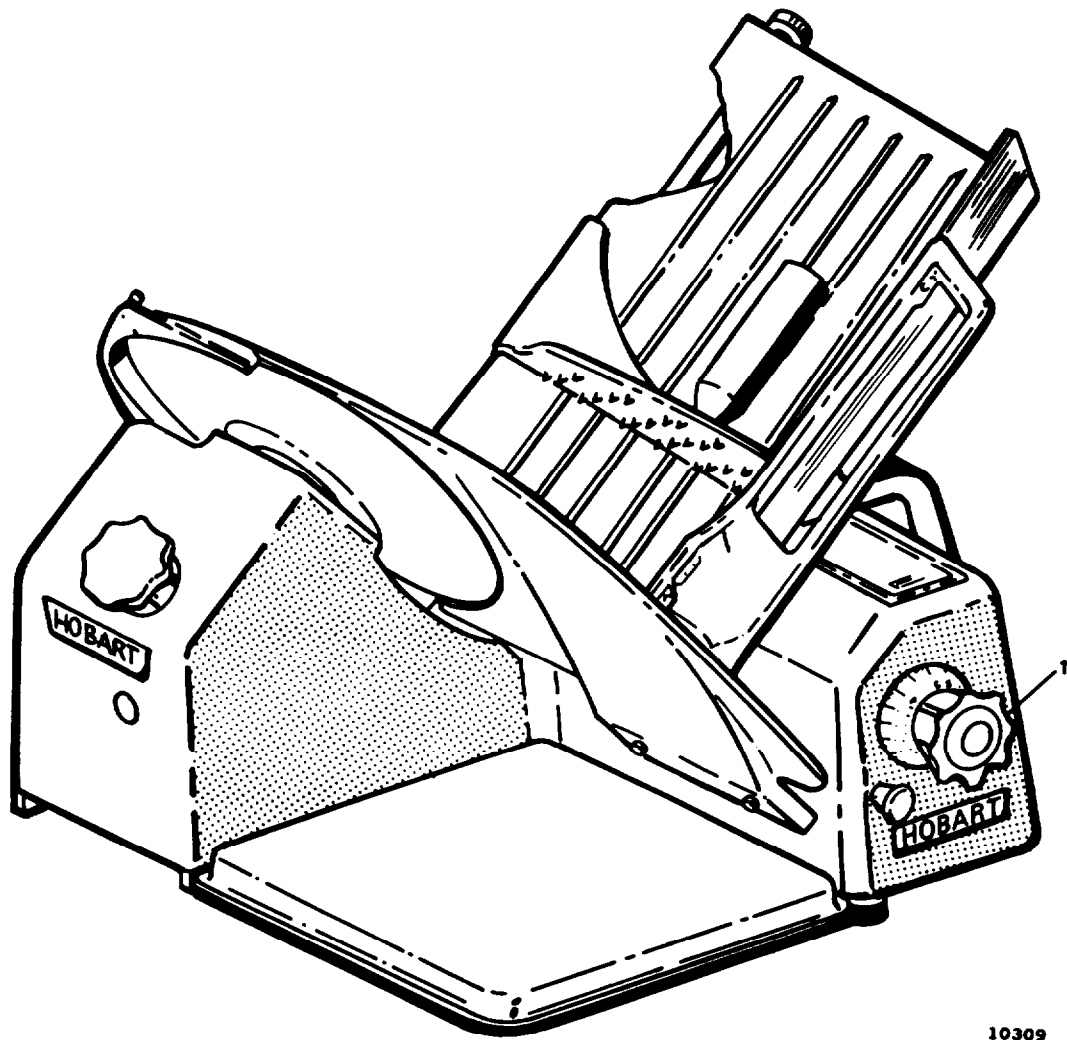


FIGURE 2-51. Meat Slicing Machine.

---

2-61. Replace Carriage Unit Assembly. (FIGURE 2-52)

---

This task covers: a. Removal, b. Replacement.

---

### **INITIAL SETUP**

#### **Tools**

Tool kit, general mechanic's  
5180-00-699-5273

#### **Equipment Condition**

Meat slicing machine secured and  
tagged "Out of Service - Do Not  
Operate."

#### **Materials/Parts**

Carriage unit assembly  
P/N PL-18497-1  
Warning tags, Item 1, Appendix C

---

### **REMOVAL**

- a. Unplug electrical cord from receptacle.
- b. Remove thumb screw (3) and belleville washer (2).
- c. Remove meat carriage tray (1) from carriage and bushing assembly (4).

### **REPLACEMENT**

- a. Install meat carriage tray (1) on carriage and bushing assembly (4)

#### NOTE

When installing carriage tray, the washers  
(2) must be on the outside, next to the  
thumb screw, to fit properly.

- b. Install belleville washer (2) and thumb screw (3).
- c. Plug electrical cord into receptacle and remove warning tag.

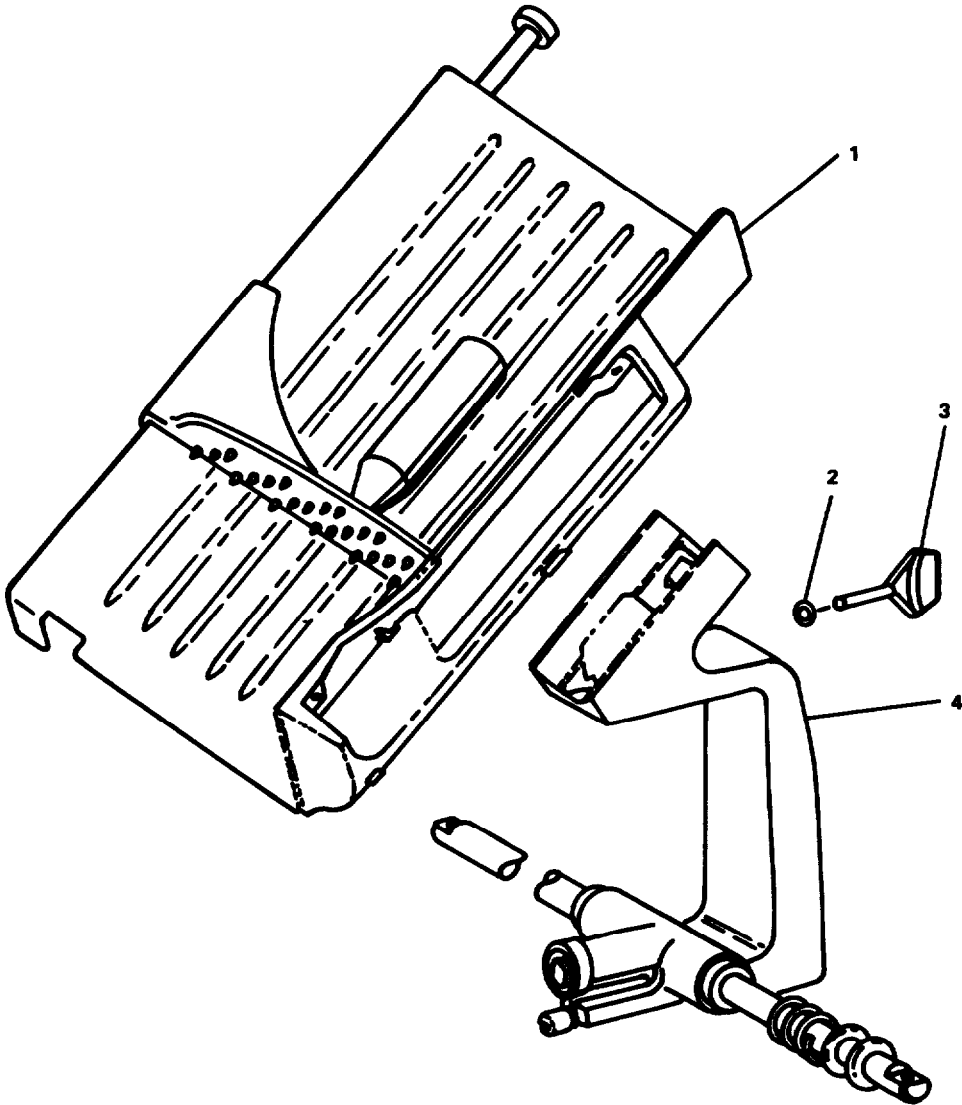


FIGURE 2-52. Carriage Unit Assembly.

---

2-62. Replace Knife Unit Assembly.

---

This task covers: a. Removal, b. Replacement.

---

### INITIAL SETUP

#### Materials/Parts

Knife unit assembly  
P/N PL - 16270  
Warning tags, Item 1, Appendix C

#### Equipment Condition

Meat slicing machine secured and tagged "Out of Service - Do Not Operate."

---

### REMOVAL

- a. Unplug electrical cord from receptacle.
- b. Loosen locking knob.
- c. Slide knife unit assembly from base unit.

### REPLACEMENT

- a. Slide knife unit assembly on base unit.
- b. Tighten locking knob.
- c. Plug electrical cord into receptacle.

---

**2-63. Replace Gauge Plate and Indexing Mechanism. (FIGURE 2-53)**

---

This task covers: a. Removal, b. Repair, c. Replacement.

---

**INITIAL SETUP****Tools**

Tools kit, general mechanic's,  
5180-00-699-5273

**Equipment Condition**

Meat slicing machine secured and  
tagged "Cut of Service - Do Not  
Operate."

**Materials/Parts**

Gauge plate and indexing mechanism  
P/N PL-13891  
Gauge plate and slide rod assembly  
P/N E-118328  
Warning tags, Item 1, Appendix C

---

**REMOVAL**

- a. Unplug electrical cord from receptacle.
- b. Remove hexagon capscrew (14) and spacer (15).
- c. Remove gauge plate assembly (1).
- d. Remove machine screw (13), cap (12), and dial assembly (11).
- e. Remove roll pin (9) and meat slicer index disc (10).
- f. Remove nut (8) and Belleville washer (7).
- g. Remove set screw (6) and eccentric bushing (5).
- h. Remove roll pin (2), index assembly worm (3), and nut (4).
- i. Remove self-tapping screw (16), index gear assembly (17), and roller (18).
- j. Remove slide rod and spacer assembly (19).

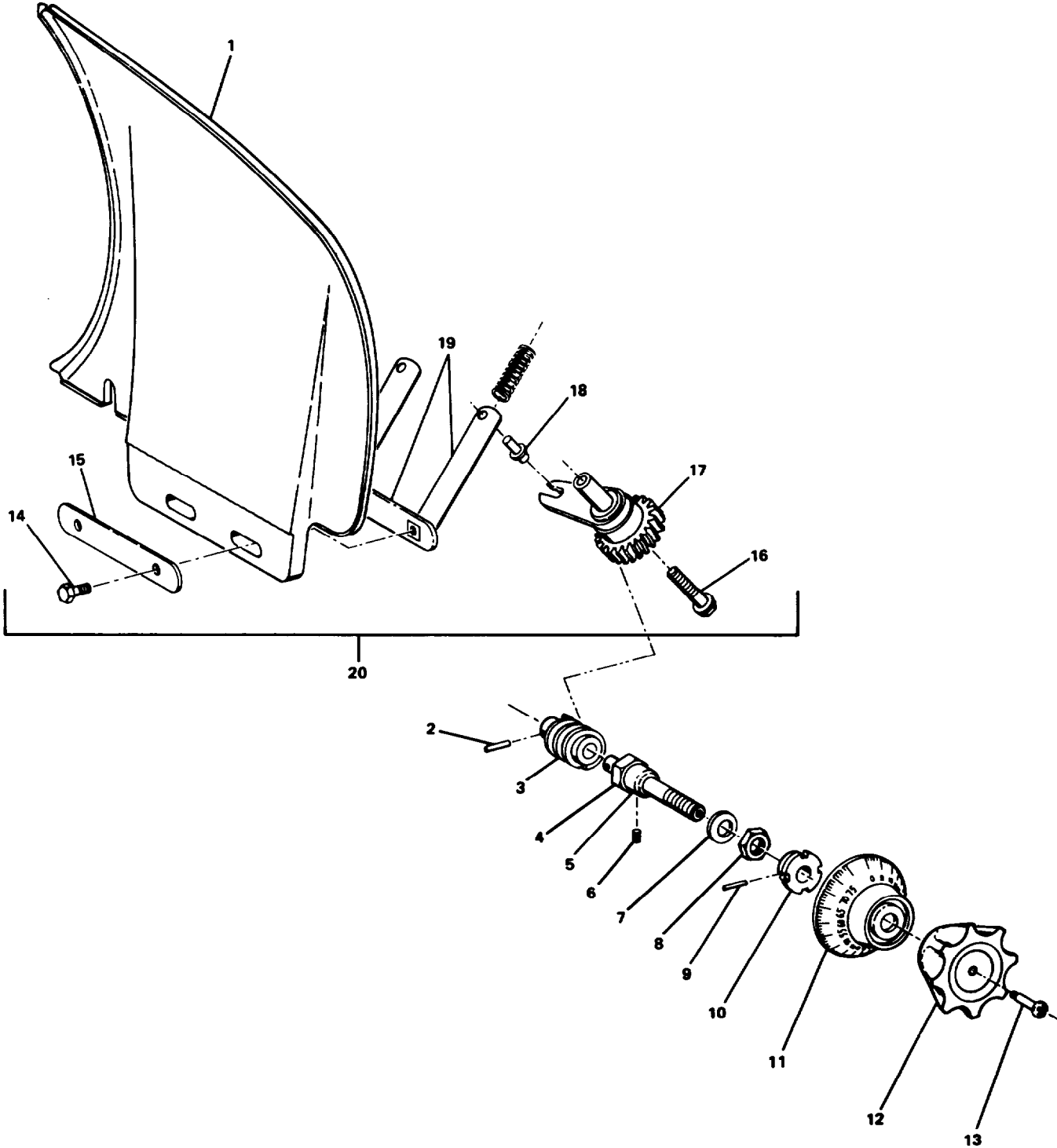
**REPAIR**

Repair at this level of maintenance is by replacement of the gauge plate and slide rod assembly (20).

---

REPLACEMENT

- a. Install slide rod and spacer assembly (19) and gauge plate assembly (1).
- b. Install spacer (15) and hexagon capscrew (14).



10314

FIGURE 2-53. Gauge Plate and Indexing Mechanism.

- c. Install roller (18). index gear assembly (17), and self-tapping screw (16).
- d. Install nut (4) index assembly worm (3) and roll pin (2).
- e. Install eccentric bushing (5) and set screw (6).
- f. Install belleville washer (7) and nut (8).
- g. Install meat slicer index disc (10) and roll pin (9).
- h. Install dial assembly (11), cap (12), and machine screw (13).
- i. Replace electric meat slicing machine; refer to paragraph 2-60.



---

2-64. Replace Base Unit Assembly. (FIGURE 2-54)

---

This task covers: a. Removal, b. Replacement.

---

### INITIAL SETUP

#### Tools

Tool kit, general mechanic's,  
5180-00-699-5273

#### Materials/Parts

Base unit assembly P/N PL-15572

#### Equipment Condition

Electric meat slicing machine  
removed, para. 2-60.

Knife unit assembly removed,  
para. 2-62.

Gauge plate and indexing mechanism  
removed, para. 2-63.

Carriage unit assembly removed,  
para. 2-61.

Gauge plate and slide rod assembly  
removed, para. 2-63.

---

### REMOVAL

- a. Remove knob (1).
- b. Remove self-tapping screw (3) and panel (2).
- c. Remove foot (5).
- d. Remove helper foot (8).
- e. Remove self-tapping screw (7) and bottom cover (9).
- f. Remove tray (6) and base and logo plate assembly (4).

### REPLACEMENT

- a. Install tray (6) and base and logo plate assembly (4).
- b. Install bottom cover (9) and attach with self-tapping screw (7).
- c. Install helper foot (8).
- d. Install foot (5).
- e. Install panel (2) and attach with self-tapping screw (3).
- f. Install knob (1).

g. Refer to paragraphs 2-60, 2-61, 2-62, 3-71, and 3-72.

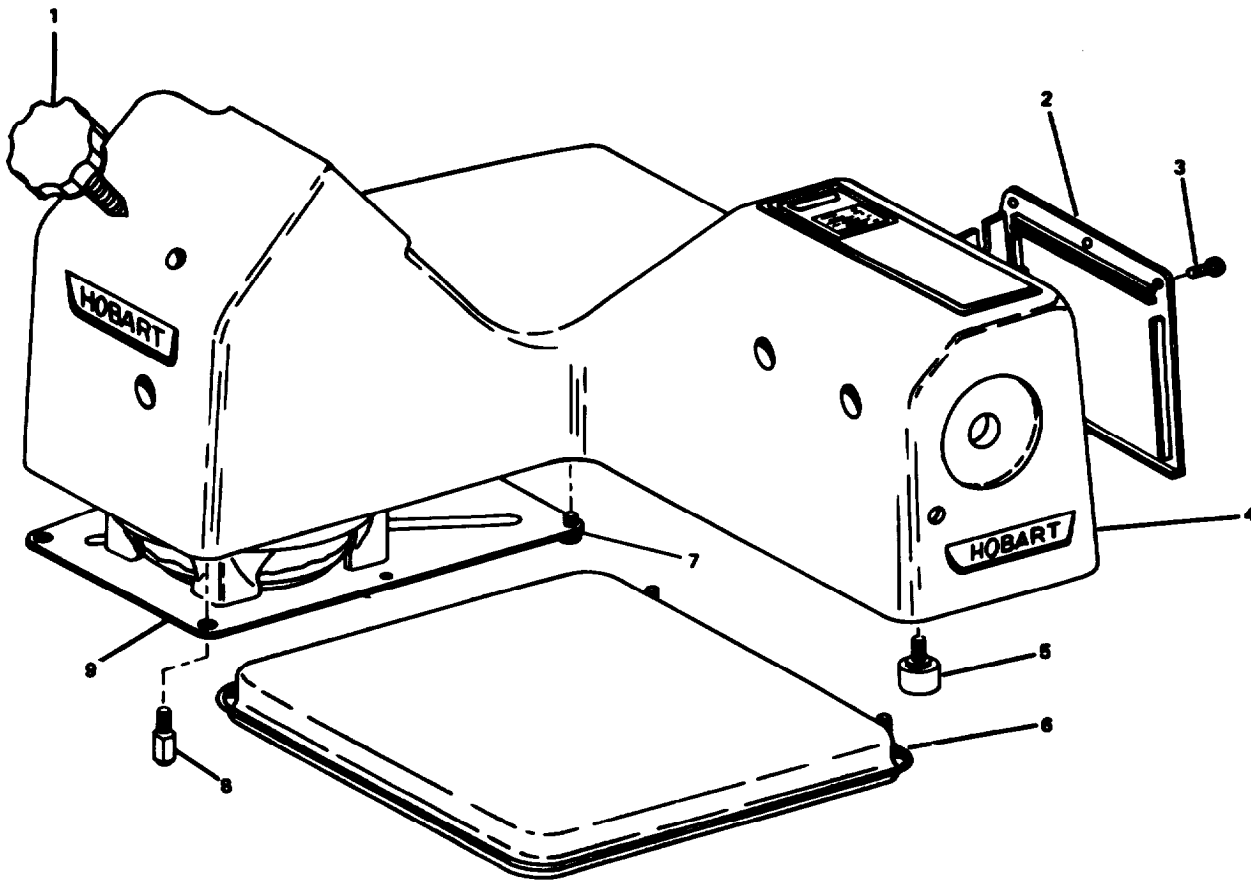


FIGURE 2-54. Base Unit Assembly.

---

2-65. Replace Motor.

---

This task covers: a. Removal, b. Replacement.

---

#### INITIAL SETUP

##### Tools

Tool kit, general mechanic's,  
5180-00-699-5273

##### Materials/Parts

Motor P/N PL-16505-1

---

##### Equipment Condition

Electric meat slicing machine  
removed, para. 2-60.  
Base and logo plate assembly removed,  
para. 2-64.

#### REMOVAL

- a. Remove retaining screws from bottom cover (9, FIGURE 2-59) and motor bracket, and remove motor.
- b. Tag and disconnect wiring to motor.

#### REPLACEMENT

- a. Install retaining screws through bottom cover (9, FIGURE 2-44b) to motor bracket and install motor.
- b. Connect wiring to motor and remove tags.

2-66. Replace Electrical Unit Assembly. (FIGURE 2-55)

---

This task covers: a. Removal, b. Replacement.

---

### INITIAL SETUP

#### Tools

Tool kit, general mechanic's,  
5180-00-699-5273  
Tool kit, electrician's,  
5180-00-391-1087

#### Equipment Condition

Electric meat slicing machine  
removed, para. 2-60.  
Base and logo plate removed,  
para. 2-64.

#### Materials/Parts

Electrical unit assembly P/N PL-16269  
Capacitor P/N D-70487-15  
Electrical switch P/N B-87711-148-1  
Warning tags, Item 1, Appendix C

---

### REMOVAL

- a. Tag and disconnect electrical leads from electrical switch (15).
- b. Remove switch (15) and cord and plug assembly (3).
- c. Remove strain relief (2).
- d. Tag and remove wire nut (1) from insert disc (4).
- e. Remove knob (5) insert disc (4), and bushing (12).
- f. Remove self-tapping screws (10), lockwasher (11), and plate (13).
- g. Remove insulator (14) from plate (13).

### WARNING

**Discharge capacitor before removing.**

- h. Remove capacitor (8) and capacitor end cap (6).
- i. Remove self-tapping screw (7) and bracket (9).

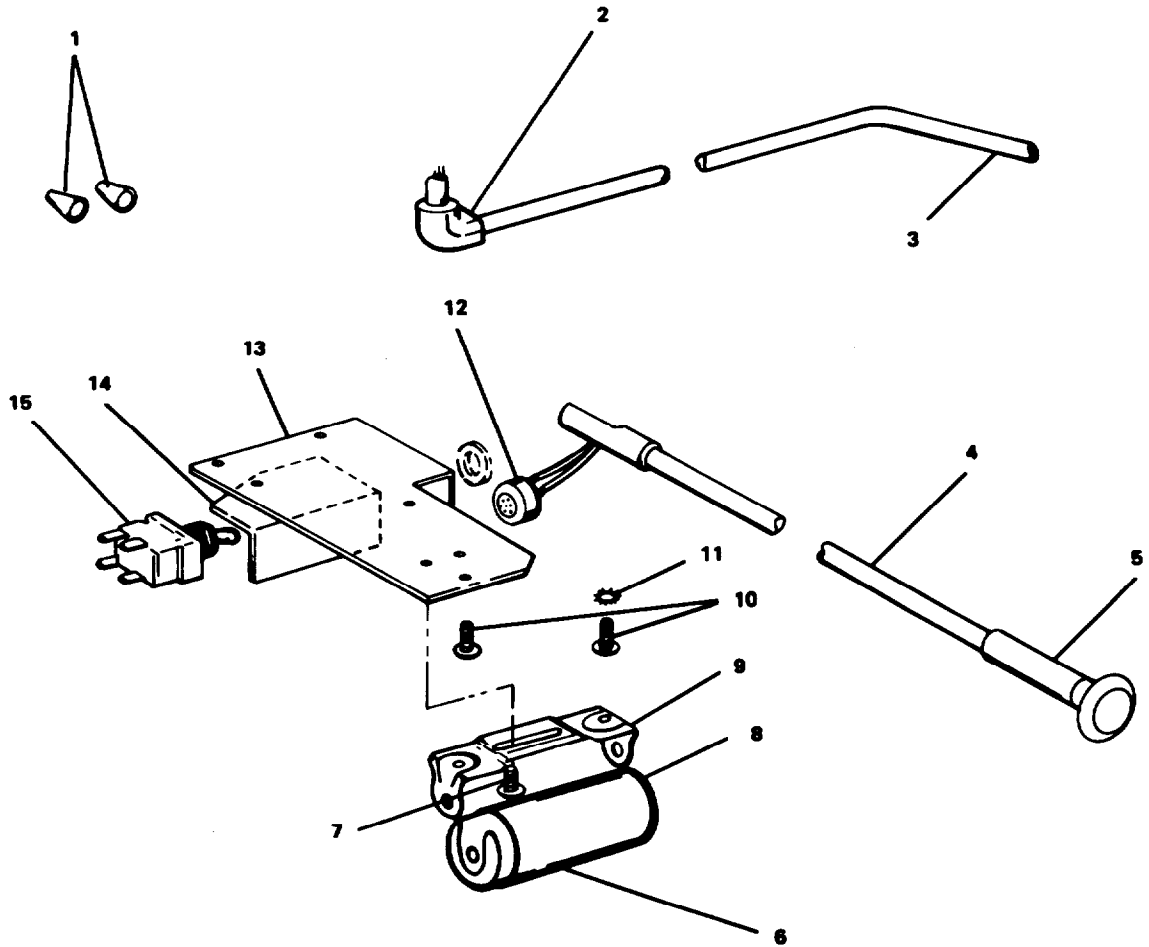


FIGURE 2-55. Electrical Unit Assembly.

REPLACEMENT

- a. Install bracket (9) and attach with self-tapping screw (7).
- b. Install capacitor (8) and capacitor end cap (6).
- c. Install insulator (14) on plate (13).
- d. Install plate (13) and attach with lockwasher (11) and self-tapping screw (10).
- e. Install bushing (12) and insert disc (4).
- f. Install knob (5).
- g. Remove tags connect electrical leads with wire nut (1).
- h. Install strain relief (2).
- i. Install switch (15) and cord and plug assembly (3).
- j. Remove tags and connect electrical leads to switch (15).
- k. Replace base and logo plate and electric meat slicing machine; refer to paragraphs 2-64 and 2-60, respectively.

---

2-67. Replace Knife Sharpener Unit. (FIGURE 2-56)

---

This task covers: a. Removal, b. Replacement.

---

### INITIAL SETUP

#### Tools

Tool kit, general mechanic's,  
5180-00-699-5273

#### Equipment Condition

Electric meat slicing machine  
removed, para. 2-60.

#### Materials/Parts

Knife sharpener unit P/N PL-13892

---

### REMOVAL

- a. Remove machine screw (6) and grinding wheel (2) from knife sharpener unit assembly (1).
- b. Remove machine screw (3) and catch (4) from mounting plate (5).

### REPLACEMENT

- a. Install catch (4) on mounting plate (5) with machine screws (3).
- b. Install grinding wheel (2) on knife sharpener unit assembly (1) with machine screw (6).
- c. Refer to paragraph 2-60.

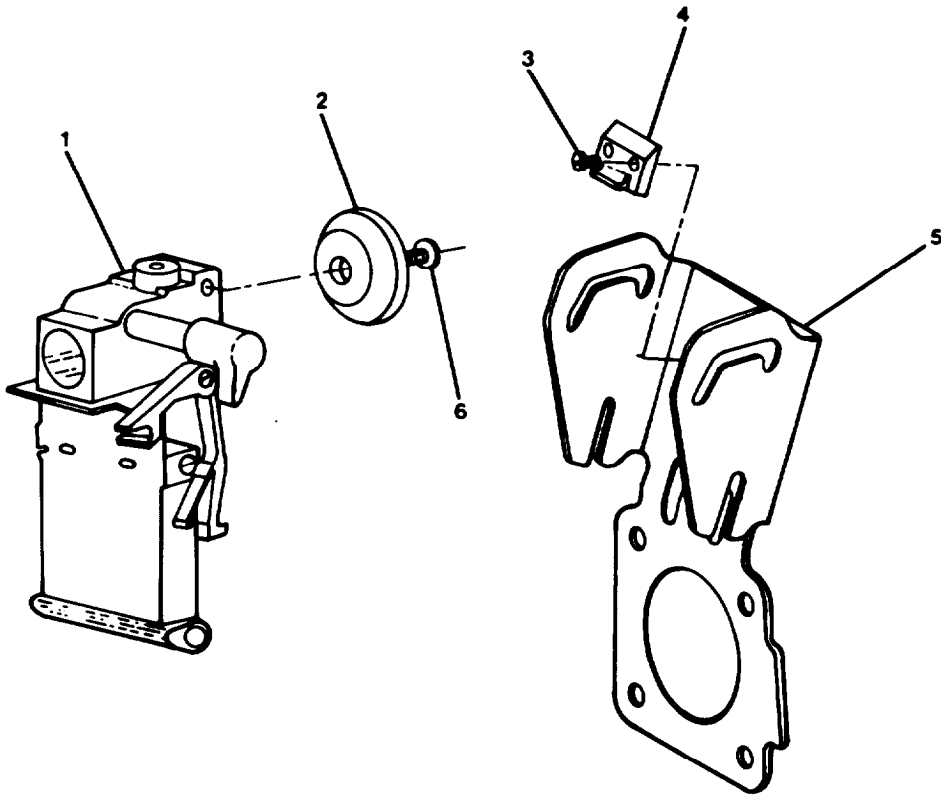


FIGURE 2-56. Knife Sharpener Unit.



---

2-68. Replace/Repair R-20 Mechanical Refrigerator. (Figure 2-57)

---

This task covers: a. Removal, b. Repair, c. Replacement.

---

### INITIAL SETUP

#### Tools

Tool kit, general mechanic's,  
5180-00-699-5273  
Tool kit, electrician's,  
5180-00-391-1087

#### Equipment Condition

Electrical power turned OFF at  
galley 240V power panel. Switch  
tagged "Out of Service - Do Not  
Operate."

#### Materials/Parts

Refrigerator P/N R20-2M-S  
Warning tags, Item 1, Appendix C

---

### REMOVAL

- a. Tag and disconnect electrical leads.
- b. Remove mounting bolts.
- c. Remove refrigerator.

### REPAIR

Repair at this level of maintenance is by replacement of refrigerator condenser (2) and evaporator coil (1) units. Refer to paragraphs 2-69 and 2-70, respectively.

### REPLACEMENT

- a. Install refrigerator.
- b. Install mounting bolts.
- c. Remove tags and connect electrical leads.
- d. Remove tag and turn on electrical power at galley 240V power panel.

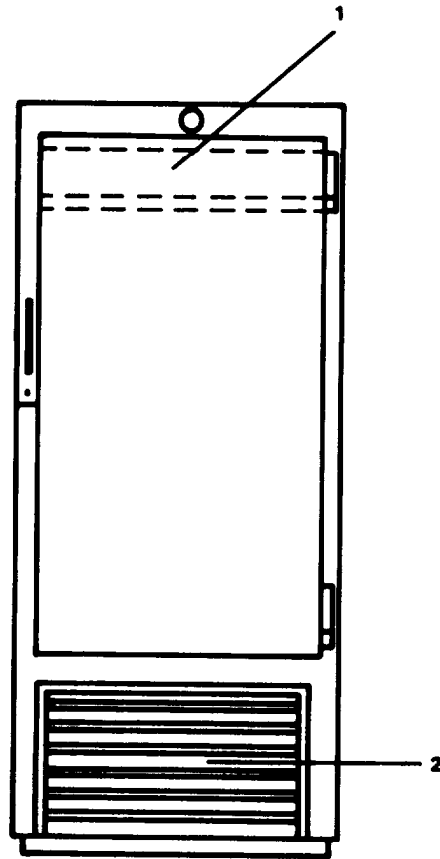


FIGURE 2-57. R-20 Mechanical Refrigerator/Freezer.

---

2-69. Replace R-20 Mechanical Refrigerator - Refrigeration Condenser.  
(Figure 2-58)

---

This task covers: a. Removal, b. Replacement.

---

INITIAL SETUP

Tools

Tool kit, general mechanic's,  
5180-00-699-5273  
Tool kit, electrician's,  
5180-00-391-1087  
Tool kit, refrigeration and  
air conditioning,  
5180-00-596-1474

Equipment Condition

Electrical power turned OFF at galley  
240V power panel. Switch tagged "Out  
of Service - Do Not Operate."

Materials/Parts

Refrigerator condenser  
P/N AE4430AC  
Warning tags, Item 1,  
Appendix C  
Refrigerant R-12, Item 38,  
Appendix C  
Empty clean refrigerant container,  
Item 39, Appendix C

---

REMOVAL

- a. Remove grill from cabinet by lifting up and pulling out at bottom of unit.
- b. Remove mount bolt at center front of base.
- c. Slide condenser unit and base (1) out of cabinet.

**CAUTION**

Ensure gauge manifold handwheels are shut before  
attaching hoses to system.

- d. Remove protective caps and attach gauge manifold hoses to respective  
suction and discharge (high pressure) service valves connections.
- e. Attach common middle hose to empty steel R-12 storage cylinder.

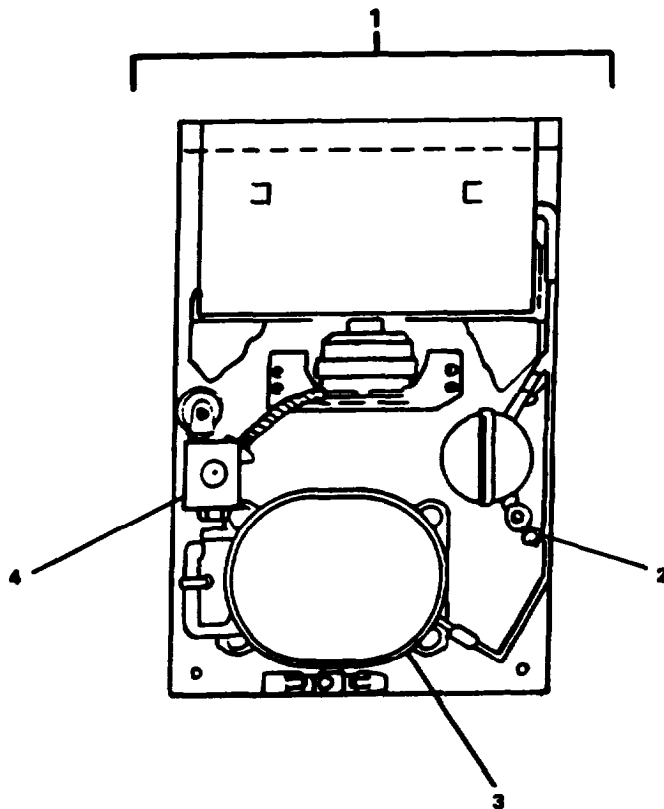


FIGURE 2-58. Refrigeration Condenser.

**WARNING**

**PRESSURIZED GAS HAZARD. Handle R-12 refrigerant containers with care to avoid personal injury. Keep containers away from external heat sources. DO NOT DROP containers. When in use, place containers where they will not be knocked over.**

- f. Place the empty R-1 container upright in a larger open container (bucket) of cold water. Add ice as necessary to keep water cold while removing charge.

**NOTE**

The system contains approximately 30 lbs of R-12 refrigerant. Make sure to obtain enough empty containers to hold the refrigerant being removed. Make sure to weigh each empty container and record the weight before removing refrigerant.

- g. If compressor (3) is operational, perform the following:

**NOTE**

If storing of the refrigerant charge in the condenser unit is practical for the expected maintenance, refer to paragraph 2-70.

- (1) Remove tag and turn on power to cabinet
- (2) Open the gauge manifold discharge (high pressure) handwheel, open the empty R-12 container valve, and the compressor will pump the refrigerant charge into the empty container.

**WARNING**

**DO NOT OVERFILL CONTAINER. Use additional containers as necessary. Weigh container to determine capacity.**

**NOTE**

After majority of refrigerant charge is transferred and pressures on gauge manifold are low, efficient transfer of remainder refrigerant is not possible.

- (3) Shut R-12 storage container valve and remove hoseline to container to vent remaining refrigerant to the atmosphere.
- (4) Turn off power to cabinet and tag.

- h. If compressor (3) is not operational, perform the following:
- (1) Open both gauge manifold handwheels to permit refrigerant to migrate (bleed) down to storage container.
  - (2) Open the storage container valve.

**NOTE**

Ensure the suction and discharge service valves are open.

**WARNING**

**DO NOT OVERFILL CONTAINER. Use additional containers as necessary. Weigh containers to determine capacity.**

**NOTE**

After majority of refrigerant charge is transferred and pressures on gauge manifold are low, efficient transfer of remainder refrigerant is not possible.

- (3) Shut R-12 storage container valve and remove hose line to storage container to vent remaining refrigerant to the atmosphere.
- i. Open (sweat off) the system copper tubing lines at the suction service valve fitting and at the discharge service valve fitting.
  - j. Tag and disconnect electrical wiring at control panel (4).
  - k. Lower front of condenser unit and base (1) and pull unit forward the remaining distance to remove unit from cabinet.

**REPLACEMENT**

- a. Install condenser unit and base (1) in cabinet by raising rear of unit enough to clear center retaining bolt frame component.
- b. Slide condenser unit and base into cabinet minimum distance to permit access for system hookup.
- c. Sweat on suction and discharge (high pressure) copper lines at respective service valve fittings.
- d. Attach gauge manifold hoses to respective service valve connections. Shut both gauge manifold handwheels.

- e. To evacuate system, perform the following:

**NOTE**

If the refrigerant charge is stored in the condenser unit receiver, refer to paragraph 2-70 for evacuating and charging procedures.

- (1) Attach refrigeration vacuum pump to gauge manifold middle hoseline.

**CAUTION**

Make sure the oil level in the compressor is at the half-way point in the observation window before evacuating.

- (2) Open both suction and discharge (high pressure) service valves.  
(3) Start and run the vacuum pump.  
(4) Slowly open both gauge manifold handwheels.

**NOTE**

Evacuation of system may be a slow process.

- (5) Evacuate system until a minimum 18 inches Hg. is indicated on vacuum pump gage.  
(6) Turn off refrigeration vacuum pump.

**NOTE**

Observe vacuum reading for approximately 15 minutes to ensure sweat joints are good and system is capable of holding a charge.

- (7) If system does not hold vacuum, check tightness of hoseline and if necessary, resweat fittings previously made.

**NOTE**

When vacuum reading is maintained for 15 minutes, system is ready to be charged.

- (8) Shut both gauge manifold handwheels and remove refrigerant vacuum pump from middle hoseline.

f. To charge system with R-12, perform the following:

**WARNING**

**PRESSURIZED GAS HAZARD. Handle R-12 refrigerant containers with care to avoid personal injury. Keep containers away from external heat sources. DO NOT DROP containers. When in use, place containers where they will not be knocked over.**

**NOTE**

System holds 30 lbs. of R-12 refrigerant. Make sure enough R-12 refrigerant is on hand to fill system. Weigh and record supply container weight to check quality used when charge is complete.

- (1) Attach middle gauge manifold hose to R-12 supply container.
- (2) Momentarily crack open the supply container valve then shut. loosen the middle hose at the manifold to purge the hose then re-tighten.
- (3) Connect electrical wiring at control panel (4), remove tags, and turn on power to cabinet.

**WARNING**

**Do not use water warmer than 110°F to avoid over-expansion of refrigerant in container.**

- (4) Place the R-12 supply container upright in a container of warm water that is no warmer than 110°F. This will maintain container pressure and expedite charging.

**WARNING**

DO NOT apply heat with a torch.

- (5) Start compressor (3).
- (6) Slowly open suction side gauge manifold handwheel to permit system charging.

**NOTE**

Do not open discharge (high pressure) handwheel. Observe gauge manifold gages and system sight glass (2).



- (7) System is fully charged when operating pressures are between 23-44 psig for suction side and 120-135 psig for discharge (high pressure) side.
  - (8) Check sight glass (2) to ensure no bubbles appear. If bubbles appear, crack suction side handwheel to add more refrigerant until bubbles do not appear in sight glass.
  - (9) Weigh the R-12 supply container and subtract this weight from previously recorded valve to determine amount of R-12 refrigerant used.
  - (10) If in excess of unit data plate information, turn off compressor (3).
  - (11) Shut R-12 supply container valve and the gauge manifold suction side handwheel.
  - (12) Remove middle hoseline to supply container.
  - (13) Momentarily crack the suction side handwheel to vent refrigerant to atmosphere.
  - (14) Start compressor, allow to run 5 minutes and check operating pressures and sight glass (2) proper indications.
  - (15) When charging is complete, stop compressor (3) and remove gauge manifold hoses.
  - (16) Install protective caps on service valve stems.
- g. Install condenser unit and base (3) in cabinet.
  - h. Install mount bolt at center front of base.
  - i. Install grill in front of cabinet by aligning top of grill in cabinet then pushing up and in at bottom of unit.

2-70. Replace R-20 Mechanical Refrigerator - Refrigeration Evaporator Coil.  
(FIGURE 2-59)

---

This task covers: a. Removal, b. Replacement.

---

### INITIAL SETUP

#### Tools

Tool kit, general mechanic's,  
5180-00-699-5273  
Tool kit, electrician's,  
5180-00-391-1087  
Tool kit, refrigeration and air  
condition, 5180-00-596-1474

#### Equipment Condition

Electrical power turned OFF at galley  
240V power panel. Switch tagged "Out  
of Service - Do Not Operate."

#### Materials/Parts

Warning tags, Item 1, Appendix C  
Refrigerant R-12, Item 38, Appendix C

---

### REMOVAL

- a. To store the refrigerant charge in the condensing unit receiver, perform the following:
  - (1) Remove grill from cabinet by lifting up and pulling out at bottom of unit.
  - (2) Remove mount bolt at center of base.
  - (3) Slide condenser unit and base out of cabinet.

#### **CAUTION**

Ensure gauge manifold handwheels are shut before  
attaching hose lines to system.

- (4) Remove protective cap and attach gauge manifold suction baselines to the  
suction service valve connection.
- (5) Shut discharge (high pressure) service valve at the receiver.
- (6) Turn on power to cabinet.

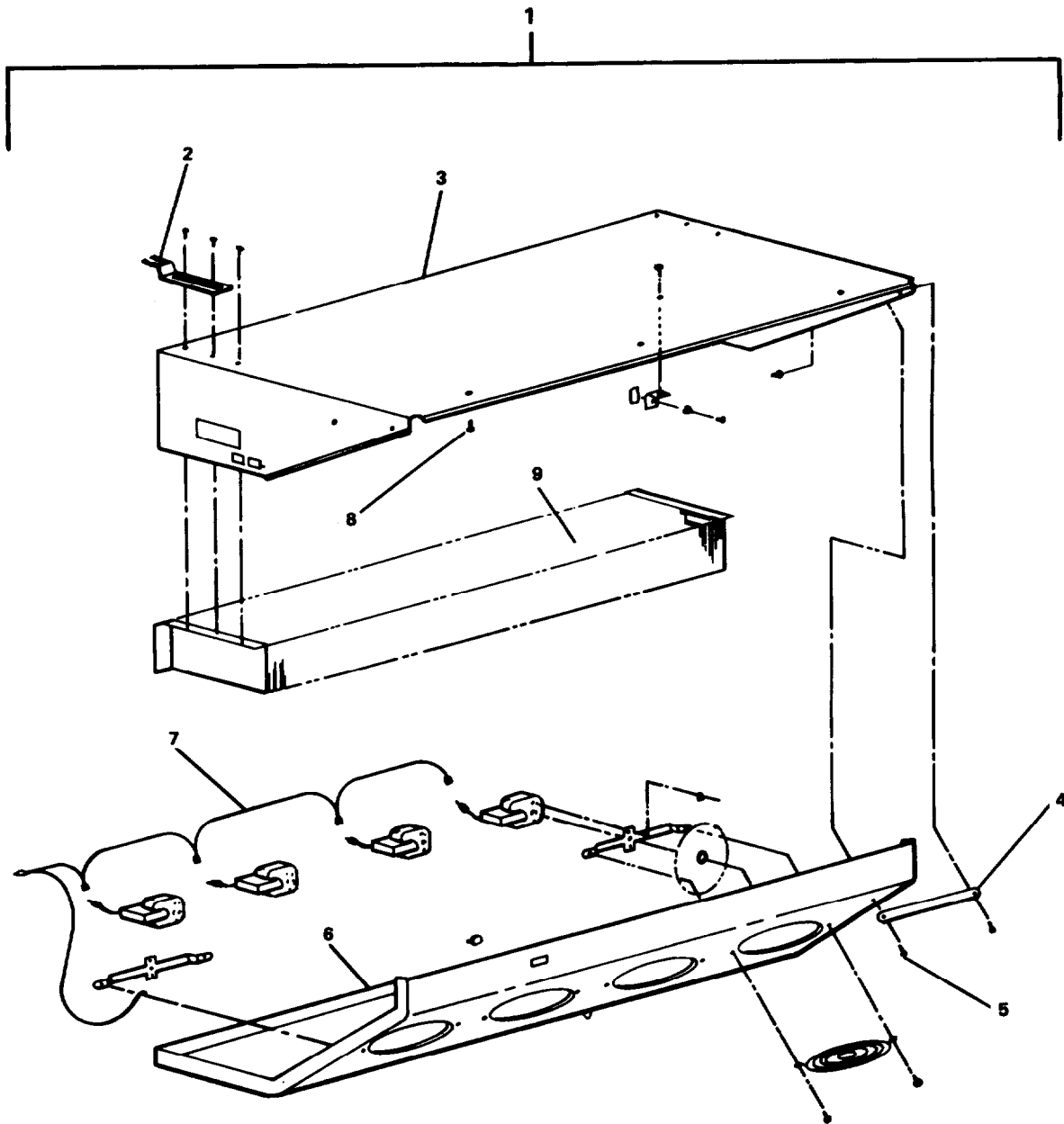


FIGURE 2-59. Refrigeration Evaporator Coil.

**NOTE**

Observe the gauge manifold suction side gage. As the compressor pumps the refrigerant charge into the receiver, the suction side pressure is reduced. When suction pressure is reduced to 0 psig, turn off power.

- (7) Remove gauge manifold hose line and install protective cap on the suction service valve connection.
- (8) Slide condenser unit and base into cabinet for better access to evaporator coil.
- b. Open cabinet doors to access evaporator coil assembly.
- c. Remove screws retaining bottom housing (6) to top housing (3).
- d. lower bottom housing (6) slowly until lanyard (4) retains unit and provides enough room to access fan motor harness (7) electrical plug.
- e. Disconnect electrical plug.
- f. Remove screw (5) to free lanyard (4).
- g. Remove bottom housing (6) from cabinet.
- h. Remove evaporator coil (9) drain hose from hose connection on bottom side of unit.

**WARNING**

**PRESSURIZED GAS HAZARD. Make sure system refrigerant charge pressure has been relieved before removing system components.**

- i. Sweat off evaporator coil (9) fittings.
- j. Remove electrical plug in junction box in top housing (3) to remove all electrical leads to evaporator coil assembly (1).
- k. Slightly loosen screws in back corners of evaporator coil assembly (1) to free brackets (2).

**CAUTION**

Hold top housing up while removing mount screws (8) to prevent unit dropping.

- l. Remove screws (8).
- m. Slide top housing (3) and evaporator coil (9) slightly forward off bracket (2) mount screw and remove from cabinet.

REPLACEMENT**NOTE**

Ensure lanyard (4) is installed on top housing(s) and retaining screws for bracket (2) are installed in cabinet interior top with enough clearance to install bracket.

- a. Install top housing (3) in cabinet.
- b. Install screw (8) and tighten bracket (2) retaining screws behind top housing (3).
- c. Sweat on evaporator coil lines to fittings.
- d. Install evaporator coil (9) drain hose to hose connection.
- e. Connect electrical plug to junction box in top housing (3).
- f. Install bottom housing (6) in top housing (3).
- g. Install lanyard (4) in bottom housing (6) with screw (5).
- h. Connect fan motor harness (7) electrical plug.
- i. Push bottom housing (6) up and into top housing (3).

**NOTE**

Ensure bottom housing outer edge is behind top housing outer edge.

- j. Install bottom housing to top housing retaining screws.
- k. If the refrigerant charge was stored in the condenser unit receiver during evaporator coil removal, performing the following:

**NOTE**

If the complete system must be evacuated and charged, refer to paragraph 2-69.

- (1) Slide the condenser unit and base out of cabinet.

**CAUTION**

Ensure gauge manifold handwheels are shut before attaching hose lines to system.

- (2) Attach the suction gauge manifold hose line to the suction side service valve connection.
- (3) Attach refrigeration vacuum pump to gauge manifold middle hose line.

**CAUTION**

Make sure the oil level in the compressor is at the half-way point in the observation window before evacuating.

- (4) Start and run the vacuum pump.
- (5) Slowly open the suction side gauge manifold handwheel.

**NOTE**

Evacuation of system may be a slow process.

- (6) Evacuate system until a minimum 18 inches of vacuum (Hg) is indicated on vacuum pump gage.
- (7) Turn off refrigeration vacuum pump.

**NOTE**

Observe vacuum reading for approximately 15 minutes to ensure sweat joints are good and system is capable of holding a charge.

- (8) If system does not hold vacuum check all hose line fittings tight and if necessary, resweat fittings previously made.

**NOTE**

When vacuum reading is maintained for 15 minutes system is ready to be charge.

- (9) Remove refrigeration vacuum pump from middle hose line.
- (10) Attach discharge (high pressure) gauge manifold hose line to the discharge service valve connection.
- (11) Slowly open discharge service valve.
- (12) Remove tags and turn on power to cabinet.
- (13) Run compressor for 5 minutes.
- (14) Observe sight glass for no bubbles and gauge manifold system operating pressures of 23-44 psig for suction side and 120-135 psig for discharge (high pressure) side.
- (15) If additional refrigerant charge is required, refer to paragraph 2-69 charging procedures.
- (16) Remove gauge manifold hose line connections and install protective caps on service valve stems.
- (17) Install condenser unit and base in cabinet, refer to paragraph 2-69.

---

2-71. Replace/Repair F-20 Mechanical Food Freezer.

---

This task covers: a. Removal, b. Repair, c. Replacement.

---

### INITIAL SETUP

#### Tools

Tool kit, general mechanic's,  
5180-00-699-5273  
Tool kit, electrician's,  
5180-00-391-1087

#### Equipment Condition

Electrical power turned OFF at  
galley 240V power panel. Switch  
tagged "Out of Service - Do Not  
Operate."

#### Materials/Parts

Mechanical freezer P/N F20-2M-ADS  
Warning tags, Item 1, Appendix C

---

### REMOVAL

- a. Tag and disconnect electrical leads.
- b. Remove mounting bolts.
- c. Remove freezer.

### REPAIR

Repair at this level of maintenance is by replacement of mechanical food freezer condenser (2, FIGURE 2-57) and evaporator coil (1) units. Refer to paragraphs 2-72 and 2-73, respectively.

### REPLACEMENT

- a. Install freezer.
- b. Install mounting bolts.
- c. Remove tags and connect electrical leads.
- d. Remove tag and turn on electrical power at galley 240V power panel.

---

2-72. Replace F-20 Mechanical Food Freezer - Refrigeration Condenser.  
(FIGURE 2-60)

---

This task covers: a. Removal, b. Replacement.

---

### INITIAL SETUP

#### Tools

Tool kit, general mechanic's,  
5180-00-699-5273  
Tool kit, electrician's,  
5180-00-391-1087  
Tool kit, refrigeration and air  
conditioning,  
5180-00-596-1474

#### Equipment Condition

Electrical power turned OFF at galley  
240V power panel. Switch tagged "Out  
of Service - Do Not Operate."

#### Materials/Parts

Refrigeration condenser  
P/N AE 2415AC  
Warning tags, Item 1, Appendix C  
Refrigerant R-12, Item 38, Appendix C  
Empty clean refrigerant container, Item  
39, Appendix C

---

#### NOTE

Figure 2-60 is provided to identify freezer  
condenser unit components referred to in paragraph  
2-69.

### REMOVAL

Refer to paragraph 2-69.

### REPLACEMENT

Refer to paragraph 2-69.



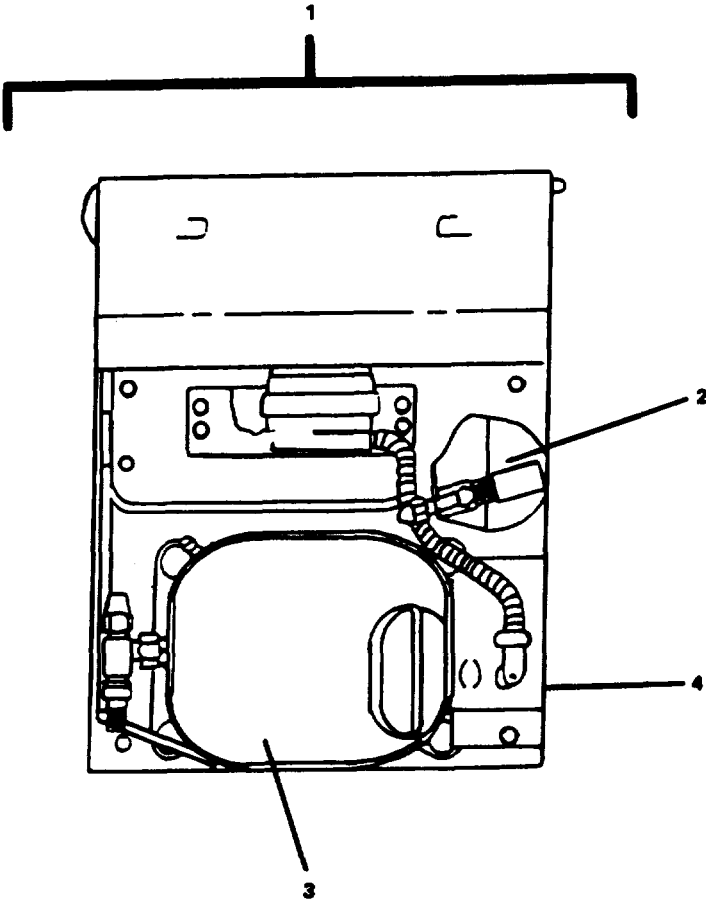


FIGURE 2-60. Freezer Refrigeration Condenser.

2-73. Replace F-20 Mechanical Food Freezer - Refrigeration Evaporator Coil.  
(FIGURE 2-61)

---

This task covers: a. Removal, b. Replacement.

---

### INITIAL SETUP

#### Tools

Tool kit, general mechanic's,  
5180-00-699-5273  
Tool kit, electrician's,  
5180-00-391-1087  
Tool kit, refrigeration and air  
conditioning,  
5180-00-596-1474

#### Equipment Condition

Electrical power turned OFF at galley  
240V power panel. Switch tagged "Out  
of Service - Do Not Operate."

#### Materials/Parts

Refrigeration evaporator  
coil P/N TL-90  
Warning tags, Item 1, Appendix C  
Refrigeration R-12, Item 38, Appendix C

---

#### NOTE

Figure 2-61 is provided to identify freezer  
evaporator coil components referred to in  
paragraph 2-70.

### REMOVAL

Refer to paragraph 2-70.

### REPLACEMENT

Refer to paragraph 2-70.

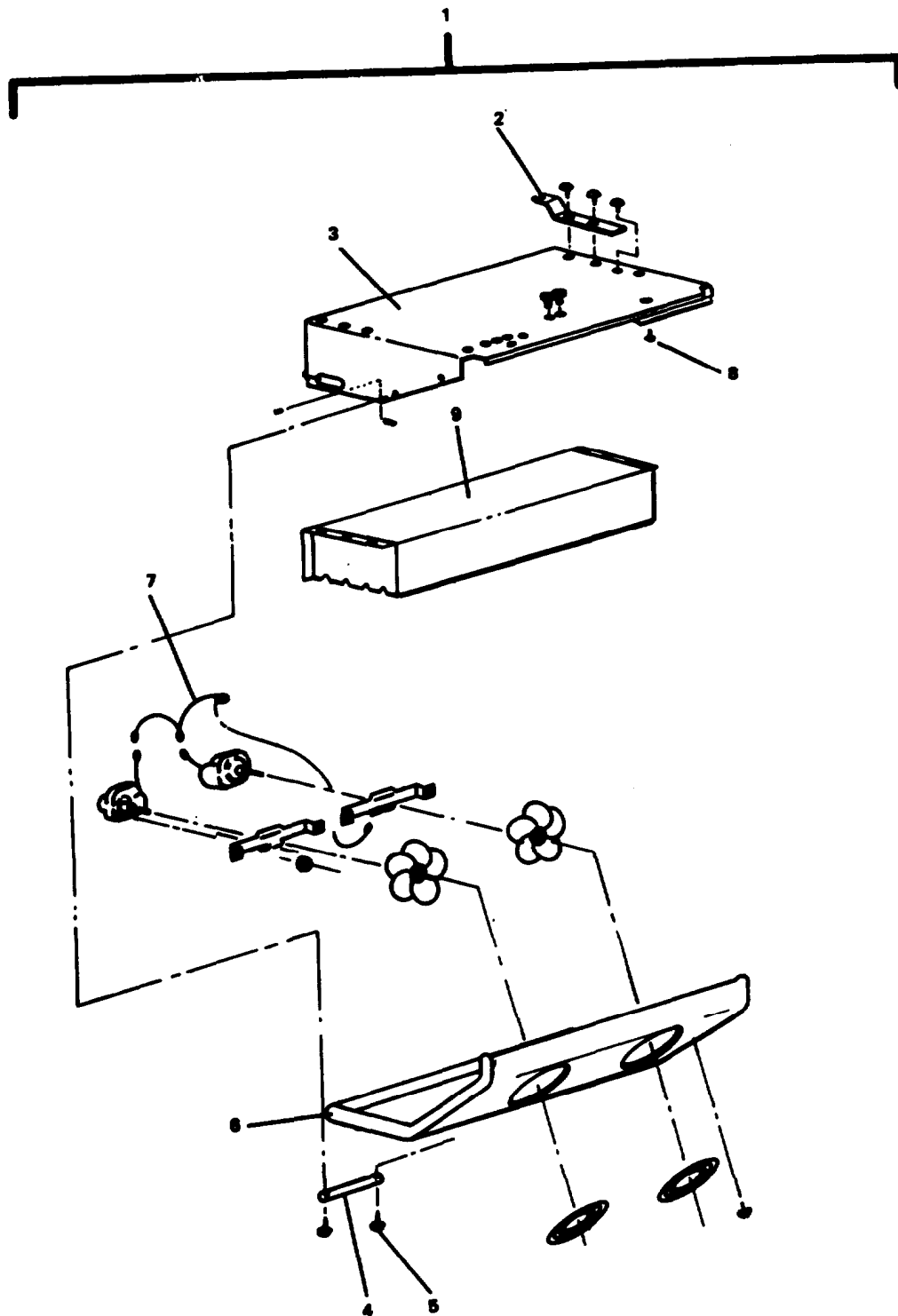


FIGURE 2-61. Freezer Refrigeration Evaporator Coil.

2-74. Replace Garbage Disposal. (FIGURE 2-62)

---

This task covers: a. Removal, b. Replacement.

---

INITIAL SETUP

Tools

Tool kit, general mechanic's,  
5180-00-699-5273  
Tool kit, electrician's,  
5180-00-391-1087

Equipment Condition

Electrical power turned OFF at galley  
240V power panel. Switch tagged "Out  
of Service - Do Not Operate."

Materials/Parts

Garbage Disposal P/N BB-325/750  
Warning tags, Item 1, Appendix C

---

REMOVAL

- a. Disconnect vacuum breaker tube from fitting (1).
- b. Disconnect drain tube from elbow (2).

WARNING

**Discharge capacitor before removing.**

- c. Tag and disconnect electrical leads from capacitor box (3).
- d. Remove bolts (5) and remove garbage disposal (4) from sink adapter.

REPLACEMENT

- a. Install garbage disposal (4) to sink adapter with bolts (5).
- b. Remove tags and connect electrical leads to capacitor box (3).
- c. Connect drain tube to elbow (2).
- d. Connect vacuum breaker tube to fitting (1).
- e. Turn on electrical power at galley 240V power panel.

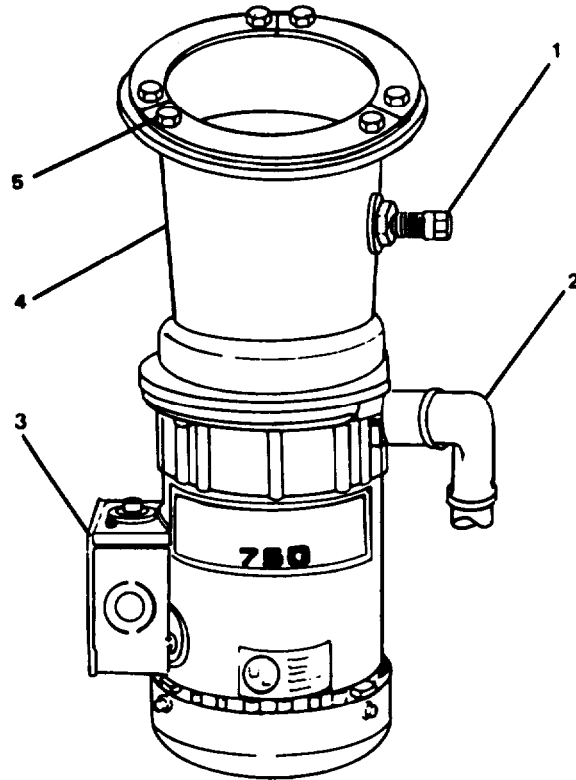


FIGURE 2-62. Garbage Disposal.

2-75. Replace Solid Waste Compactor. (FIGURE 2-63)

---

This task covers: a. Removal, b. Replacement c. Adjustment.

---

### INITIAL SETUP

#### Tools

Tool kit, general mechanic's,  
5180-00-699-5273  
Tool kit, electrician's,  
5180-00-391-1087

#### Equipment Condition

Solid waste compactor secured and  
tagged "Out of Service - Do Not  
Operate."

#### Materials/Parts

Solid waste compactor  
P/N TUB000XR  
Warning tags, Item 1, Appendix C

---

### REMOVAL

- a. Tag and disconnect wiring at electrical receptacle.
- b. Remove solid waste compactor.

### REPLACEMENT

- a. Install solid waste compactor.
- b. Connect wiring at electrical receptacle and remove tags.

### ADJUSTMENT

#### NOTE

Top limit switch stops ram assembly as it reaches top of stroke and direction switch changes current to different start windings to change direction of ram.

- a. To adjust top limit and directional switch (4, Sheet 1) perform the following:

**NOTE**

If the unit does not shut off before the ram comes off of the power screws, adjustment is required.

- (1) Open compactor drawer (3).
  - (2) Remove machine screw (2) and remove control escutcheon (1).
  - (3) Tag and disconnect electrical leads.
  - (4) Loosen top and bottom screws (5) retaining sensitive switch (4).
  - (5) Tilt the bottom of the switch outward.
  - (6) Tighten top and bottom screws (5).
  - (7) Shut compactor drawer (3).
  - (8) Remove tags and connect electrical leads.
  - (9) Install control escutcheon (1) and machine screw (2).
  - (10) Remove out of service tags and apply power to unit.
  - (11) Cycle unit to verify proper operation.
  - (12) Repeat procedure as necessary for proper operation.
- b. To adjust the drive chain (8, Sheet 2) perform the following:
- (1) Remove solid waste compactor.
  - (2) Lay unit on side.
  - (3) Remove screw (6) and remove bottom pan (7).
  - (4) Loosen bolt (10) to permit movement of mount plate (11).
  - (5) Pull mount plate with driven gear (9) and sprocket attached to tighten drive chain (8).

**NOTE**

Adjust the drive chain to allow 1/4 inch deflection across the drive socket.

- (6) Tighten bolt (10) to secure mount plate.
- (7) Install bottom pan (7) with screw (6).
- (8) Upright unit.
- (9) Replace solid waste compactor.

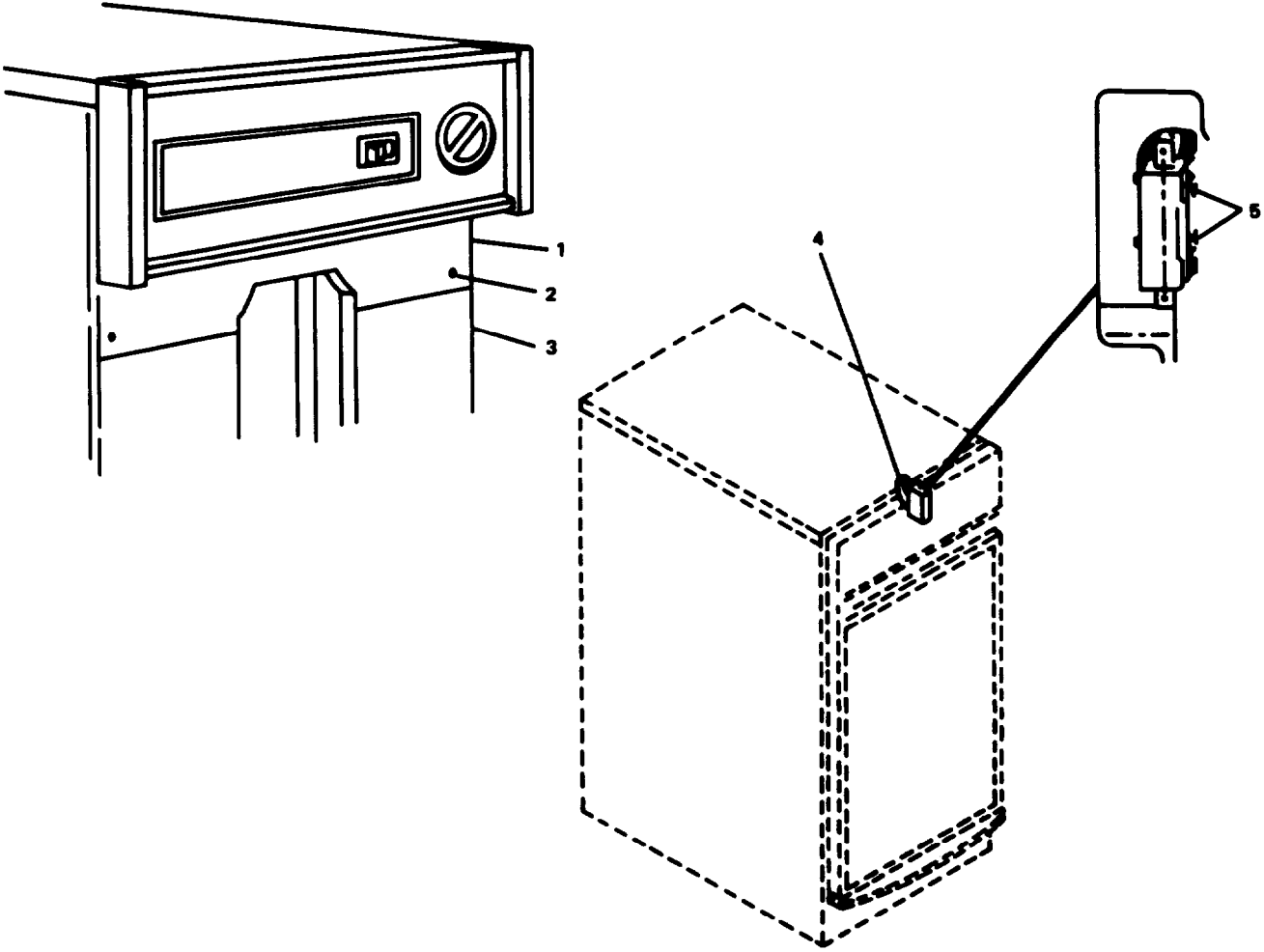


FIGURE 2-63. Solid Waste Compactor (Sheet 1 of 2.



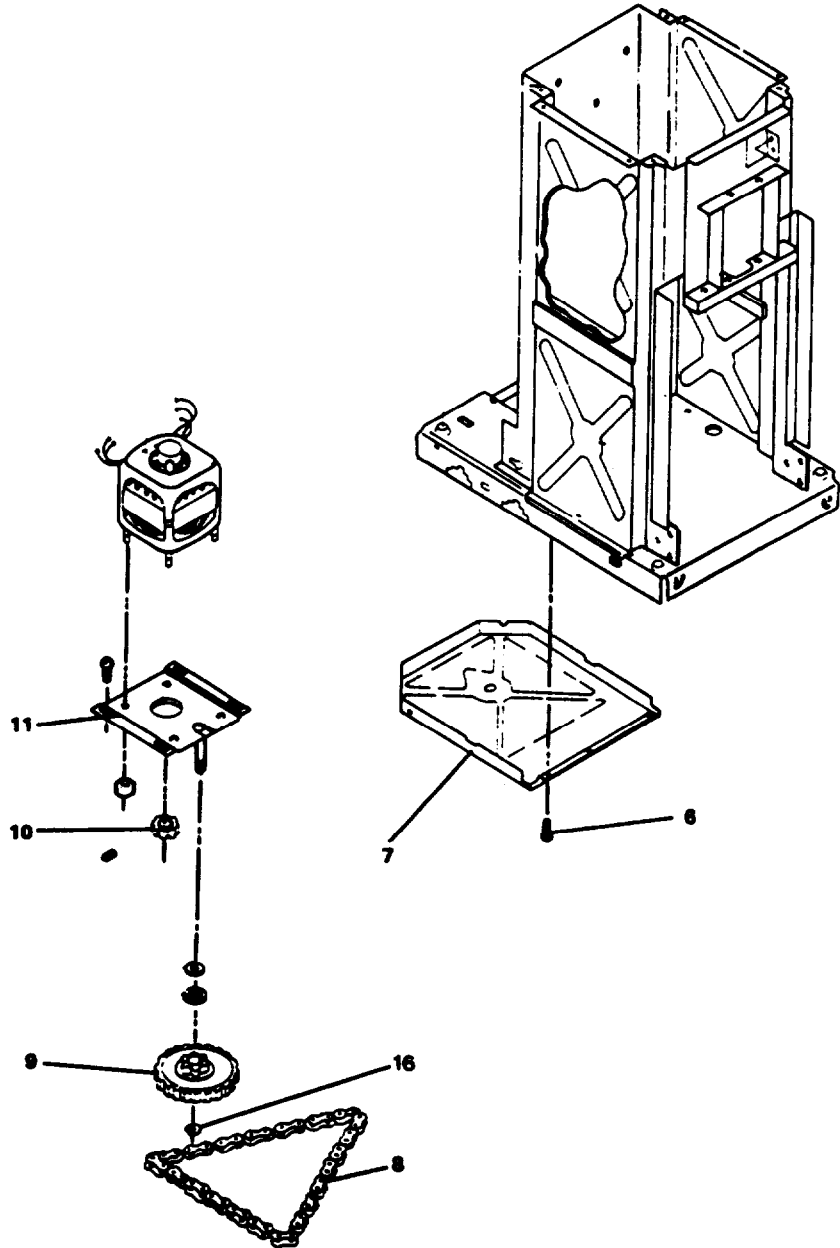


FIGURE 2-63. Solid Waste Compactor (Sheet 2 of 2).

2-76. Replace/Repair R-30 Mechanical Food Refrigerator. (FIGURE 2-64)

---

This task covers: a. Removal, b. Repair, c. Replacement.

---

### INITIAL SETUP

#### Tools

Tool kit, general mechanic's,  
5180-00-699-5273  
Tool kit, electrician's,  
5180-00-391-1087

#### Equipment Condition

Electrical power turned OFF at galley  
240V power panel. Switch tagged "Out  
of Service - Do Not Operate."

#### Materials/Parts

Mechanical food refrigerator  
P/N R30-2M-S  
Warning tags, Item 1, Appendix C

---

### REMOVAL

- a. Tag and disconnect electrical leads.
- b. Remove mounting bolts.
- c. Remove mechanical food refrigerator.

### REPAIR

Repair at this level of maintenance is by replacement of mechanical food refrigerator condenser (1) and evaporator coil (2) units. Refer to paragraphs 2-77 and 2-78, respectively.

### REPLACEMENT

- a. Install mechanical food refrigerator.
- b. Install mounting bolts.
- c. Remove tags and connect electrical leads.
- d. Remove tag and turn ON electrical power at galley 240V power panel.

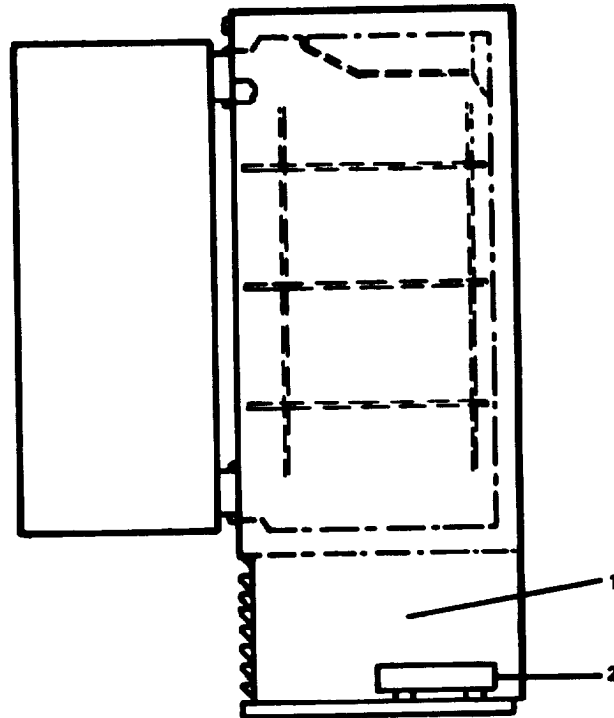


FIGURE 2-64. R-30 Mechanical Refrigerator/Freezer.

2-77. Replace R-30 Mechanical Food Refrigerator - Refrigeration Condenser.

---

This task covers: a. Removal, b. Replacement.

---

### INITIAL SETUP

#### Tools

Tool kit, general mechanic's,  
5180-00-699-5273  
Tool kit, electrician's,  
5180-00-391-1087  
Tool Kit, refrigeration and air  
conditioning,  
5180-00-596-1474

#### Equipment Condition

Electrical power turned OFF at galley  
240V power panel. Switch tagged "Out  
of Service - Do Not Operate."

### Materials/Parts

Refrigeration condenser  
P/N AE4 440AC  
Warning tags, Item 1, Appendix C  
Refrigerant R-12, Item 38, Appendix C  
Empty clean refrigerant container, Item  
39, Appendix C

---

### REMOVAL

Refer to paragraph 2-69.

### REPLACEMENT

Refer to paragraph 2-69.

---

2-78. Replace R-30 Mechanical Food Refrigeration - Refrigeration Evaporator Coil.

---

This task covers: a. Removal, b. Replacement.

---

### INITIAL SETUP

#### Tools

Tool kit, general mechanic's,  
5180-00-699-5273  
Tool kit, electrician's,  
5180-00-391-1087  
Tool kit, refrigeration and air  
conditioning,  
5180-00-596-1474

#### Equipment Condition

Electrical power turned OFF at galley  
240V power panel. Switch tagged "Out  
of Service - Do Not Operate."

#### Materials/Parts

Refrigeration evaporator  
coil P/N TA-170  
Warning tags, Item 1, Appendix C  
Refrigerant R-12, Item 38, Appendix C

---

### REMOVAL

Refer to paragraph 2-70.

### REPLACEMENT

Refer to paragraph 2-70.

2-79. Replace/Repair F-30 Mechanical Food Freezer.

---

This task covers: a. Removal, b. Repair, c. Replacement.

---

### INITIAL SETUP

#### Tools

Tool kit, general mechanic's,  
5180-00-699-5273  
Tool kit, electrician's,  
5180-00-391-1087

#### Equipment Condition

Electrical power turned OFF at galley  
240V power panel. Switch tagged "Out  
of Service - Do Not Operate."

#### Materials/Parts

Mechanical food freezer  
P/N F30-2M-ADS  
Warning tag, Item 1, Appendix C

---

### REMOVAL

- a. Tag and disconnect electrical leads.
- b. Remove mounting bolts.
- c. Remove mechanical food freezer.

### REPAIR

Repair at this level of maintenance is by replacement of mechanical food freezer condenser (2, FIGURE 2-64) and evaporator coil (1) units. Refer to paragraphs 2-80 and 2-81, respectively.

### REPLACEMENT

- a. Install mechanical food freezer.
- b. Install mounting bolts.
- c. Remove tags and connect electrical leads.
- d. Remove tag and turn ON electrical power at galley 240V power panel.

---

2-80. Replace F-30 Mechanical Freezer - Refrigeration Condenser.

---

This task covers: a. Removal, b. Replacement.

---

### INITIAL SETUP

#### Tools

Tool kit, general mechanic's,  
5180-00-699-5273  
Tool kit, electrician's,  
5180-00-391-1087  
Tool kit, refrigeration and air  
conditioning,  
5180-00-596-1474

#### Equipment Condition

Electrical power turned OFF at galley  
240V power panel. Switch tagged "Out  
of Service - Do Not Operate."

#### Materials/Parts

Refrigeration condenser  
P/N AJ2425AC  
Warning tags, Item 1, Appendix C  
Refrigerant R-12, Item 38, Appendix C  
Empty clean refrigerant container, Item  
39, Appendix C

---

### REMOVAL

Refer to paragraph 2-69.

### REPLACEMENT

Refer to paragraph 2-69.

2-81. Replace F-30 Mechanical Freezer - Refrigeration Evaporator Coil.

---

This task covers: a. Removal, b. Replacement.

---

INITIAL SETUP

Tools

Tool kit, general mechanic's,  
5180-00-699-5273  
Tool kit, electrician's,  
5180-00-391-1087  
Tool kit, refrigerant and air  
conditioning,  
5180-00-596-1474

Equipment Condition

Electrical power turned OFF at galley  
240V power panel. Switch tagged "Out  
of Service - Do Not Operate."

Materials/Parts

Refrigeration evaporator  
coil P/N TL-160  
Warning tags, Item 1, Appendix C  
Refrigerant R-12, Item 38, Appendix C

---

REMOVAL

Refer to paragraph 2-70.

REPLACEMENT

Refer to paragraph 2-70.



---

2-82. Replace Dishwasher.

---

This task covers: a. Removal, b. Replacement.

---

### INITIAL SETUP

#### Tools

Tool kit, general mechanic's,  
5180-00-699-5273  
Tool kit, electrician's,  
5180-00-391-1087

#### Equipment Condition

Electrical power turned OFF at galley  
240V power panel. Switch tagged "Out  
of Service - Do Not Operate."

#### Materials/Parts

Dishwasher P/N UC-1  
Warning tags, Item 1, Appendix C

---

### REMOVAL

- a. Remove dishwasher out from under counter top.
- b. Tag and disconnect electrical leads.
- c. Turn off water and remove hot water connection.
- d. Remove drain tube.

### REPLACEMENT

- a. Install drain tube.
- b. Install hot water connection and turn on water.
- c. Remove tags and connect electrical leads.
- d. Slide dishwasher under counter top.
- e. Remove tag and turn electrical power on at galley 240V power panel.

2-83. Replace/Repair Washer Machine.

---

This task covers: a. Removal, b. Repair, c. Replacement, d. Adjustment.

---

### INITIAL SETUP

#### Tools

Tool kit, general mechanic's,  
5180-00-699-5273  
Tool kit, electrician's,  
5180-00-391-1087

#### Equipment Condition

Electrical power turned OFF at galley  
240V power panel. Switch tagged "Out  
of Service - Do Not Operate."

#### Materials/Parts

Washer machine P/N WA-4721  
Warning tags, Item 1, Appendix C

---

### REMOVAL

- a. Tag and disconnect electrical leads.
- b. Disconnect water supply.
- c. Remove washer machine.

### REPAIR

Repair at this level of maintenance is by replacement of the mixing valve assembly and mechanical transmission. Refer to paragraphs 2-84 and 2-86, respectively.

### REPLACEMENT

- a. Install washer machine.
- b. Connect water supply.
- c. Remove tag and connect electrical leads at galley 240V power panel.

### ADJUSTMENT

Refer to paragraph 2-88 for adjustment of the motor V-belt (18, FIGURE 2-74).

---

2-84. Repair/Replace Washer Machine Water Mixing Valve. (FIGURE 2-65)

---

This task covers: a. Removal, b. Repair, c. Replacement.

---

INITIAL SETUP

Tools

Tool kit, general mechanic's,  
5180-00-699-5273

Equipment Condition

Washer machine removed, para. 2-83.  
Front panel removed and cabinet top  
hinged open, para. 2-86.

Materials/Parts

Water mixing valve P/N 27156

---

REMOVAL

- a. Loosen hose clamps (1, 3) and remove preformed hose (2).
- b. Loosen hose clamps (5, 8) and remove nonmetallic hose (7).
- c. Remove hexagon head capscrew (4) and remove check valve (6).
- d. Remove water inlet head (9).
- e. Remove machine screw (10) holding water mixing valve (13) to bracket (12).
- f. Tag and disconnect electrical leads to water mixing valve.
- g. Remove machine screw (10) holding bracket (12) to rear of washer machine.

REPAIR

Repair at this level of maintenance is by replacement of water mixing valve (13).

REPLACEMENT

- a. Install bracket (12) using machine screw (10) and speed nut (11).
- b. Install water mixing valve (13) on bracket (12) using machine screw (10) and speed nut (11).
- c. Remove tags and connect electrical leads to the water mixing valve (13).

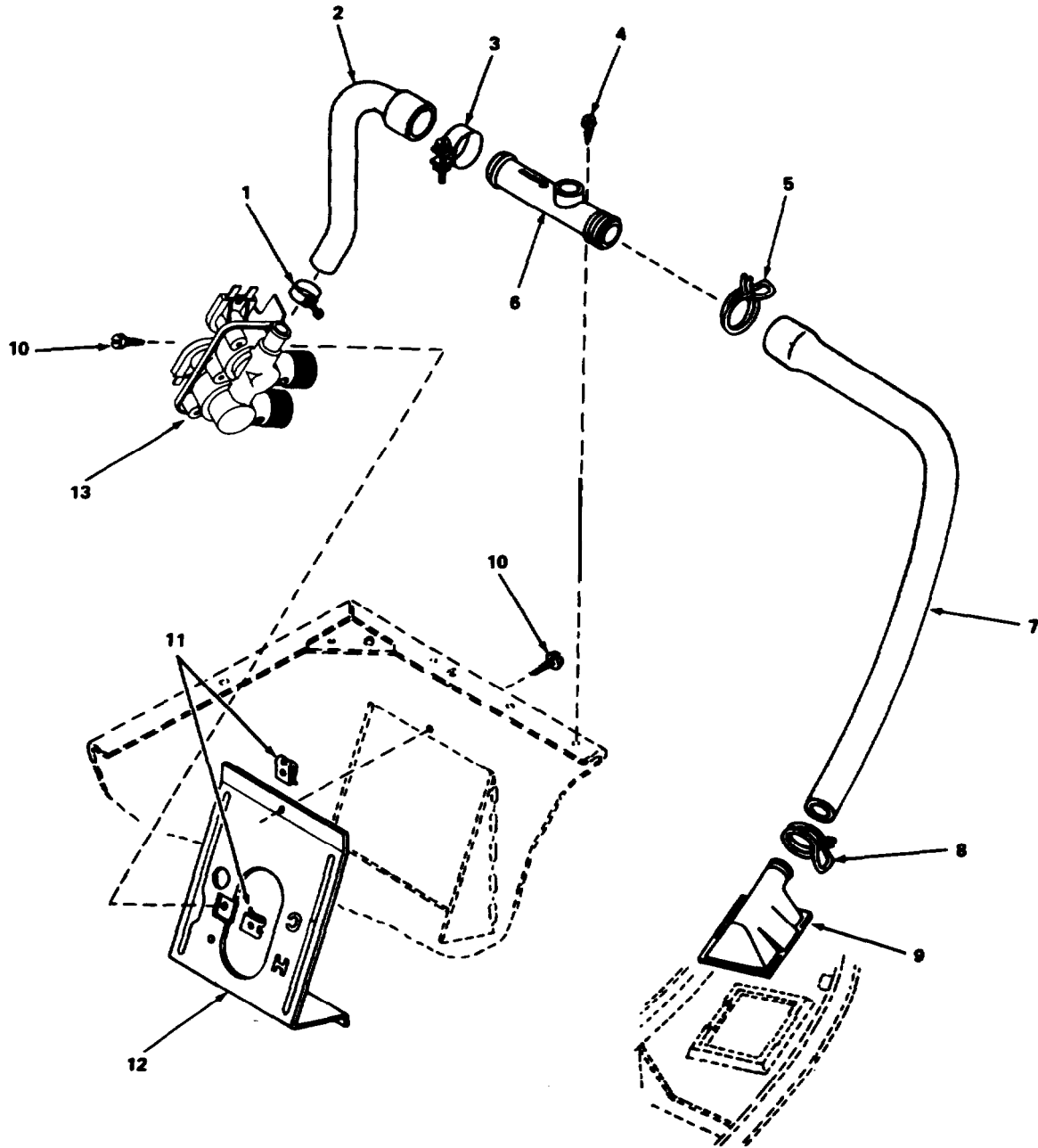


FIGURE 2-65. Washer Machine Water Mixing Valve Assembly.

**NOTE**

When installing mixing valve, tab on bottom flange must be placed in positioning hole in mounting bracket.

- d. Install water inlet head (9).
- e. Install check valve (6) using hexagon head capscrew (4).
- f. Install nonmetallic hose (7) using hose clamps (5, 8).
- g. Install performed hose (2) using hose clamps (1, 3).
- h. Refer to paragraph 2-83.

---

2-85. Removal/Replacement Washer Machine Agitator Post Assembly. (FIGURE 2-66)

---

This task covers: a. Removal, b. Replacement.

---

INITIAL SETUP

Tools

Tool kit, general mechanic's,  
5180-00-699-5273

Equipment Condition

Washer machine removed, para. 2-83.

Materials/Parts

Agitator post assembly P/N 28934

---

REMOVAL

- a. Remove socket head capscrew (1), hold-down cap (2), and flat washer (3).
- b. Remove agitator (4).
- c. Remove hexagon head capscrews (5).
- d. Remove agitator post assembly (6).

REPLACEMENT

- a. Install agitator post assembly (6) using hexagon head capscrews (5).
- b. Install agitator (4).
- c. Install flat washer (3), hold-down cap (2), and secure using socket head capscrew (1).

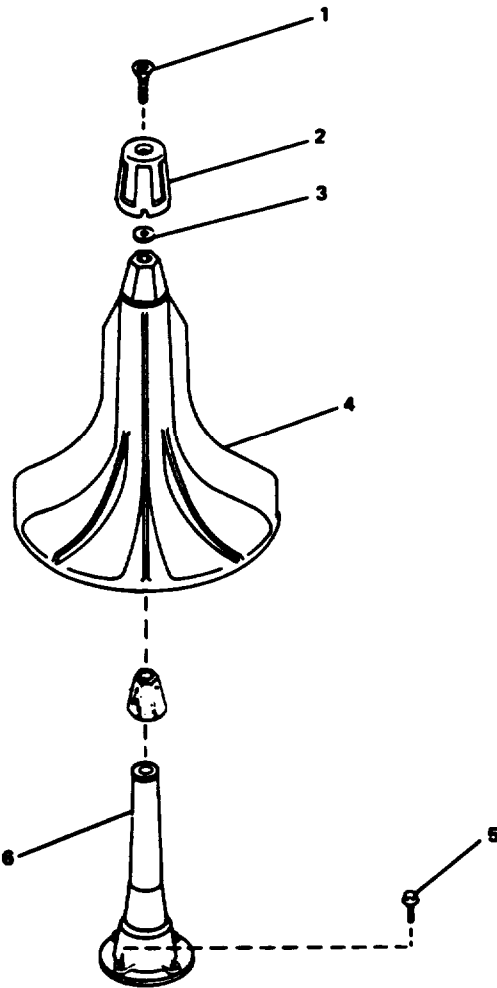


FIGURE 2-66. Washer Agitator Post Assembly.

2-86. Removal/Replacement Washer Machine Internal Components.

---

This task covers: a. Removal, b. Replacement.

---

INITIAL SETUP

Tools

Tool kit, general mechanic's,  
5180-00-699-5273  
Spring hook, No. 229P4  
Spring installer, No. 242P4  
Hex wrench, No. 237P4  
Guides spindle, No. 230P4

Equipment Condition

Washer machine removed, para. 2-83.  
Washer machine water mixing valve  
assembly removed, para. 2-84.  
Washer machine agitator post assembly  
removed, para. 2-85.

Materials/Parts

Sealer, Item 25, Appendix C  
Petroleum jelly, Item 40, Appendix C

---

REMOVAL

- a. Remove washer machine (1, FIGURE 2-67) front panel (2) as follows:
  - (1) Remove machine screws (3).
  - (2) Pull bottom of front panel (2) away from washer until hold-down clips (4) disengage from slots in cabinet top.
  - (3) Remove front panel.

**NOTE**

Washer machine cabinet top may be hinged open or removed. Refer to items b and c below.

- b. Hinge open washer machine (1, FIGURE 2-68) cabinet top (2) as follows:
  - (1) With front panel removed, remove assembled washer screw (8) and speed nut (9).
  - (2) Tape loading door (7) closed and lift cabinet top to a vertical position.



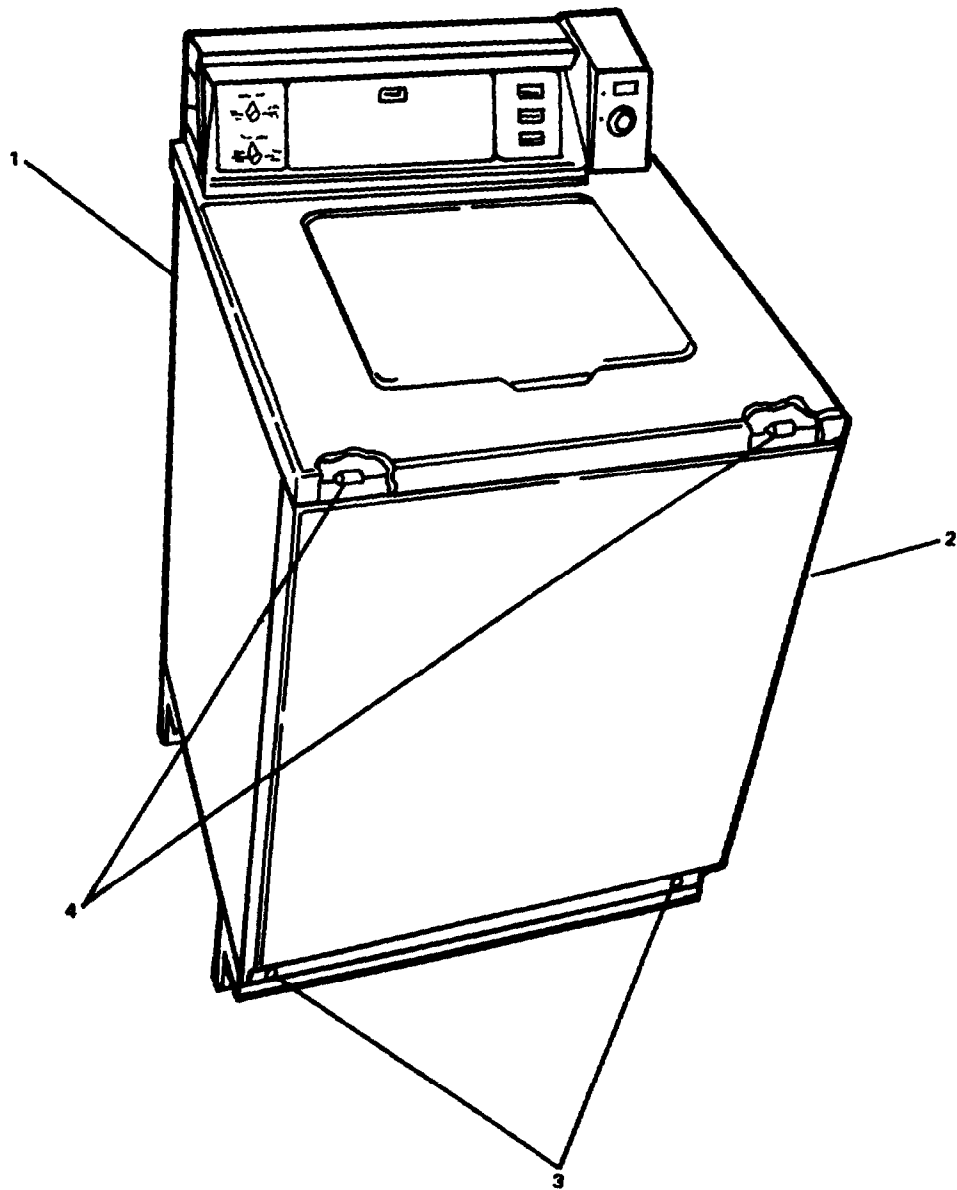


FIGURE 2-67. Washer Machine Front Panel Removal.

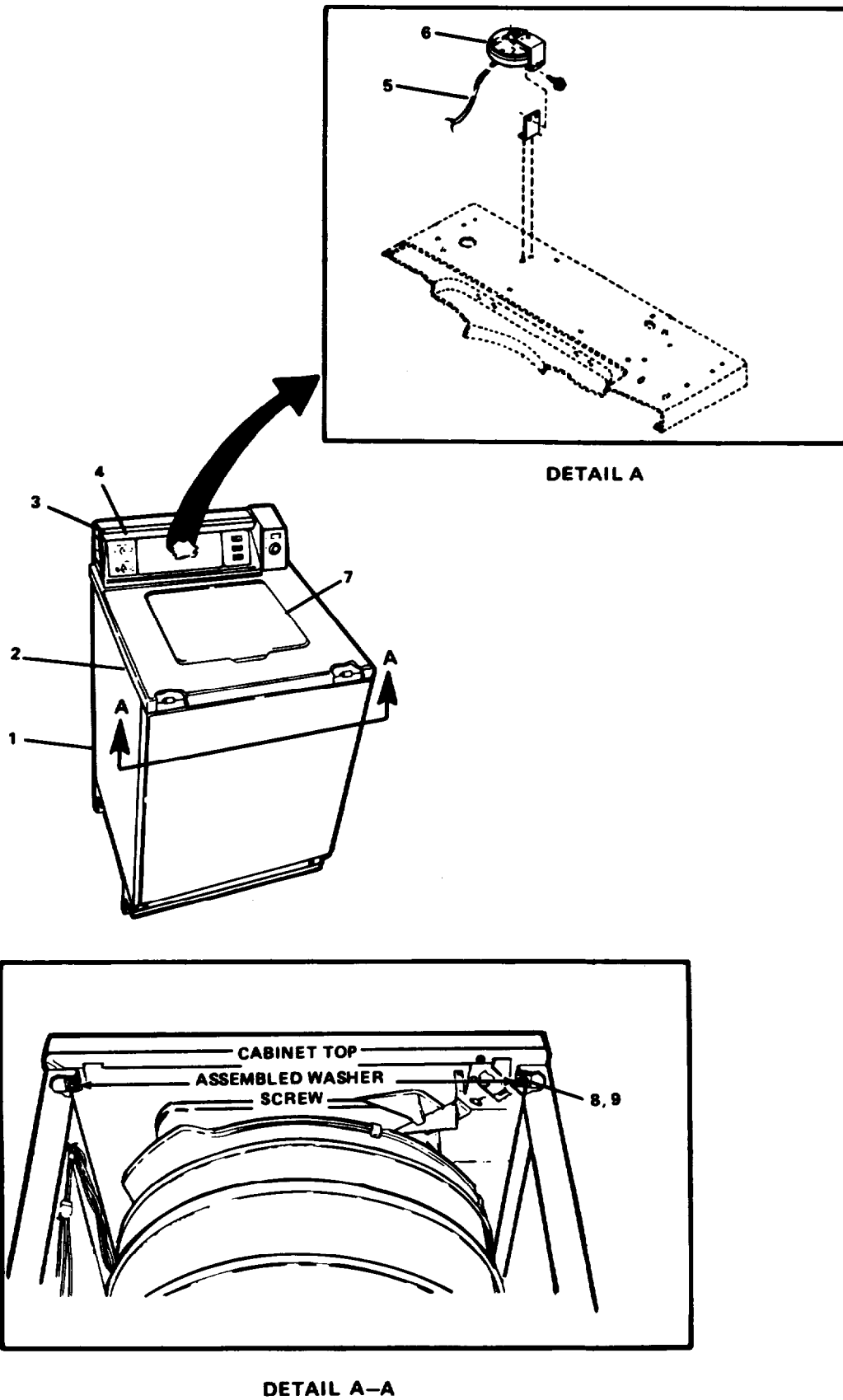


FIGURE 2-68. Washer Machine Cabinet Top Removal.

- c. Remove washer machine (1) cabinet top (2) as follows:
  - (1) Remove machine screw (3) and control panel (4).
  - (2) Disconnect control hood wire harness from base wire harness at quick disconnect block.
  - (3) Disconnect pressure hose (5) from pressure switch (6).
  - (4) Push base wire harness block and pressure hose down through hole in cabinet top.
  - (5) Tape loading door (7) closed.
  - (6) Remove assembled washer screw (8) and speed nut (9).
  - (7) Lift front of cabinet top slightly and pull forward to disengage from rear hold-down brackets and disconnect green ground wire from rear top flange of cabinet.
  - (8) Carefully lift cabinet top off washer and set on protective padding.
- d. Remove plug (1, FIGURE 2-69).
- e. Remove hexagon head capscrew (3), trigger (4) and lo&washer (2).
- f. Remove spring clip (7) and outer tube cover (5).
- g. Remove cover gasket (6).
- h. Remove hexagon head capscrew (3, FIGURE 2-70) and gasket (4).
- i. Remove washtub (5).
- j. Remove fastener (1) and lint filter (2).
- k. Remove gasket (6).
- l. Remove hexagon plain nut (7) and lockwasher (8).
- m. Remove encased plain seal (9).
- n. Remove spring (27, FIGURE 2-74).
- o. Position idle lever (9) to prevent damage when removing outer tub.

## NOTE

When removing the centering springs, mark on side of outer tube what notch the spring was hooked into. Springs must be placed in same notch when reinstalling. Do not overstretch springs.

- p. Remove center spring (9, FIGURE 2-69).

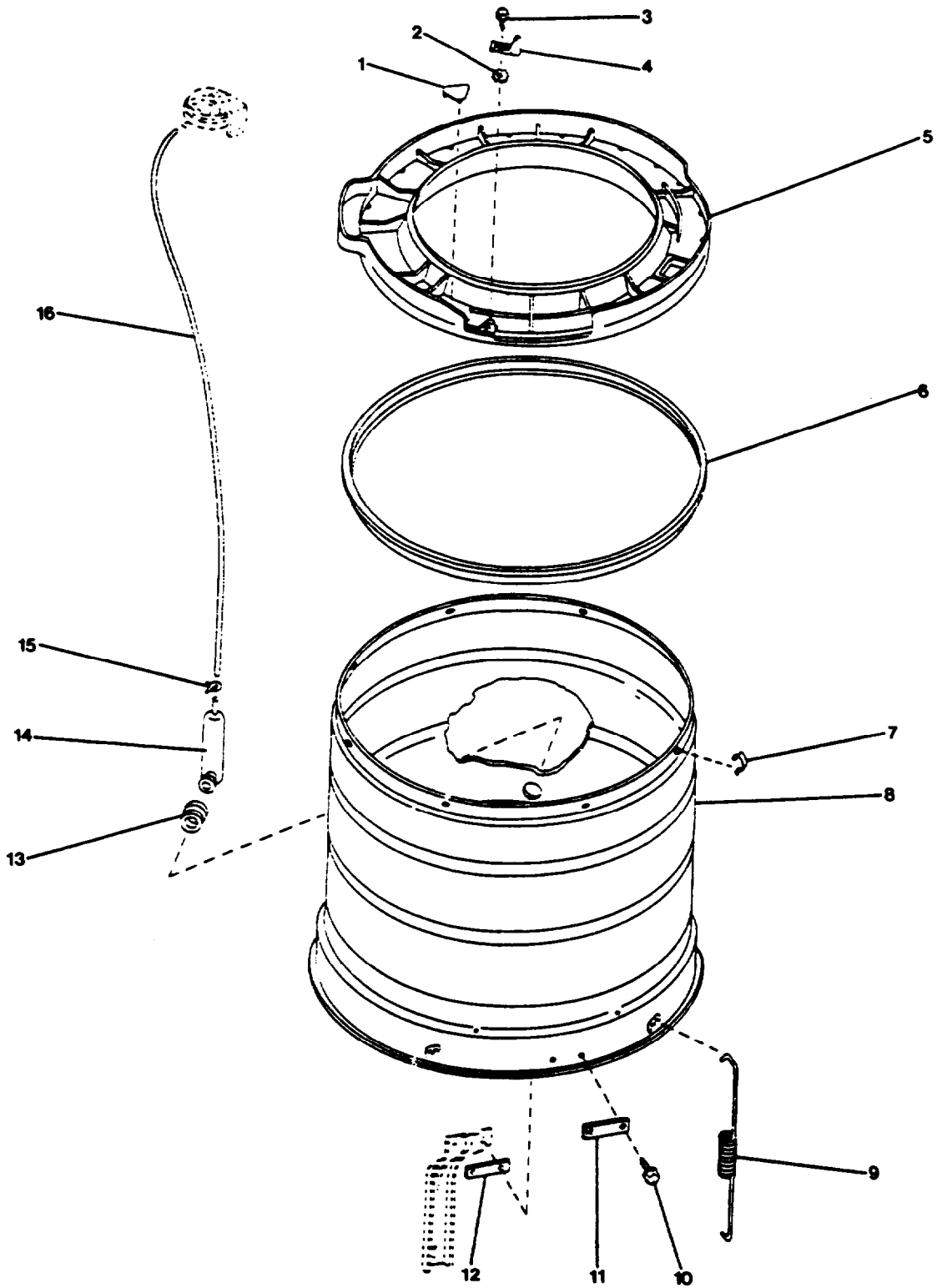


FIGURE 2-69. Washer Machine Outer Tub, Cover, and Pressure Hose Group.

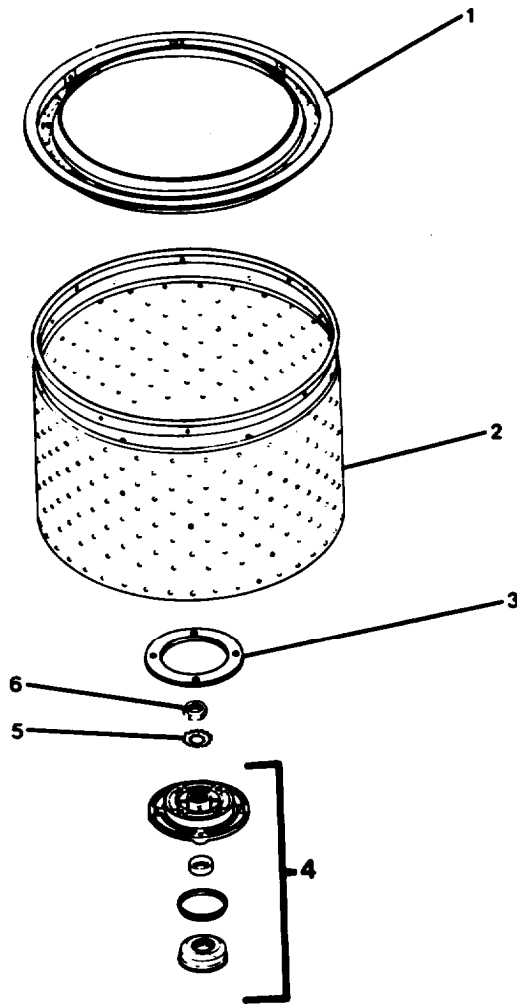


FIGURE 2-70. Washer Machine Filter, Washtub, and Hub Croup.

- q. Remove hose clamp (17, 9, FIGURE 2-73) and preformed hose (16).
- r. Loosen hose clamp (15, FIGURE 2-69) and remove pressure hose (16).
- s. Remove pressure accumulator (14) and grommet (13).
- t. Grasp outer tub and lift complete tub (with transmission, balance ring, and pivot dome attached) straight up and out of washer cabinet. Turn outer tub upside-down and set on protective padding.
- u. Remove assembled washer screw (10), leg plates (11, 12), and lift transmission, balance ring, and pivot dome groups from bottom of outer tub and set on workbench.
- v. Remove hexagon capscrew (11, FIGURE 2-71) and lockwasher (10).
- w. Remove pivot dome (12).
- x. Remove machine screw (13), flat washer (14) and helix (15).
- y. Remove groove pulley (16).
- z. Remove outer bearing rings (17, 18), retainer and roller bearing (6), flat washer (5) and helical compression spring (4).
- aa. Remove brake assembly (19) and spacer (3).
- ab. Remove shoulder screw (20), sleeve (21) and brake pad (22).
- ac. Remove hexagon capscrew (9), lockwasher (8), and leg (7).
- ad. Remove bearing housing assembly (1) and bearing (2).
- ae. Remove hexagon head capscrew (1, FIGURE 2-72) and lockwasher (2).
- af. Remove mechanical transmission (10).
- ag. Remove balance ring (3).
- ah. Remove hexagon head capscrew (4) and lockwasher (5).
- ai. Remove washer (6).
- aj. Remove bearing housing assembly (7).
- ak. Remove flinger (8).
- al. Remove retainer nut (9).

## **REPAIR**

Repair at this level of maintenance is by replacement of the mechanical transmission (10).

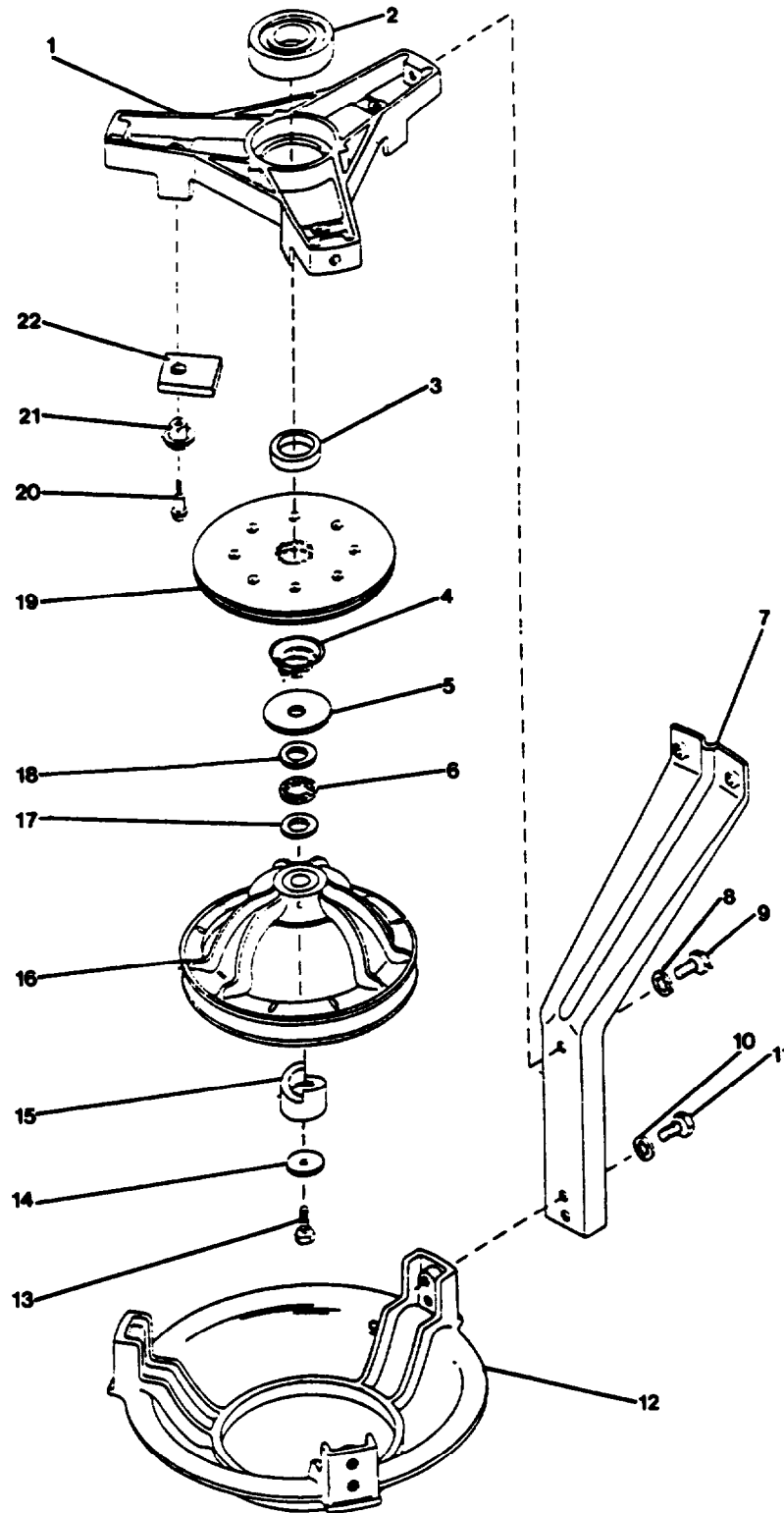


FIGURE 2-71. Washer Machine Bearing Housing, Brake/Pulley and Pivot Dome.

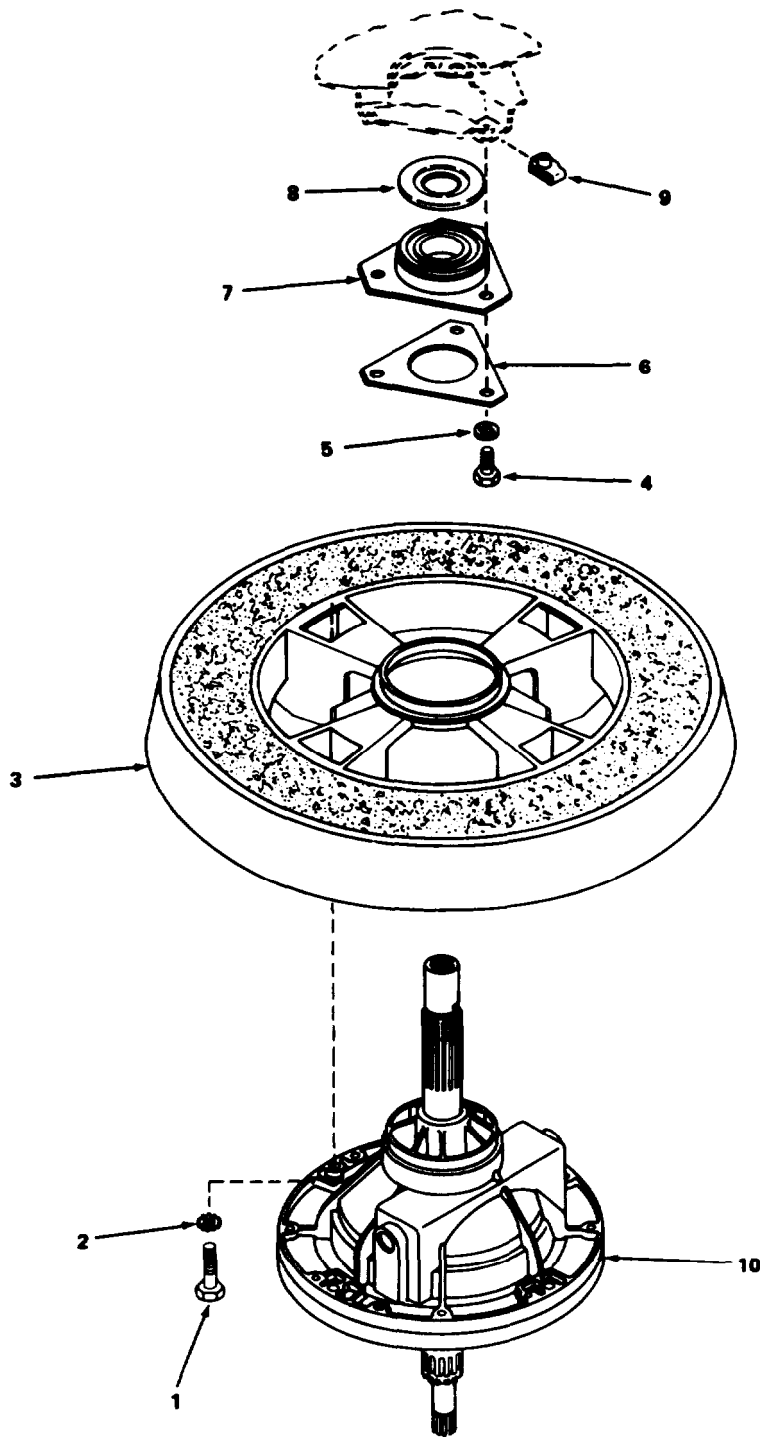


FIGURE 2-72. Transmission Group.



**REPLACEMENT**

- a. Ensure retainer nut (9) is installed on outer tub.
- b. Install flinger (8), bearing housing assembly (7), and washer (6) with hexagon head capscrew (4) and lockwasher (5).
- c. Install balance ring (3) on mechanical transmission (10).

**NOTE**

The mark located on the outer edge of the balance ring indicates the heavy side of the balance ring. This heavy side must be installed opposite the rack area of the transmission.

- d. Install lockwasher (2) and hexagon head capscrew (1).
- e. Install bearing (2, FIGURE 2-71) in bearing housing assembly (1).
- f. Install bearing housing assembly on transmission.
- g. Install brake pad (22), sleeve (21), and shoulder screw (20).
- h. Install spacer (3).
- i. Install brake assembly (19).

**NOTE**

When reinstalling helical compression spring, be sure it is inserted into groove in large spline of transmission tube.

- j. Install helical compression spring (4), flat washer (5), retainer and roller bearing (6), and outer bearing rings (18, 17).
- k. Install groove pulley (16) on transmission.
- l. Install helix (15), flat washer (14) and machine screw (13).
- m. Install leg (7) on bearing housing assembly (1) with lockwasher (8) and hexagon capscrew (9).
- n. Install pivot dome (12) on leg (7) with lockwasher (10) and hexagon capscrew (11).

**CAUTION**

Carefully lower transmission through upper bearing and flinger. Do not drop or lower transmission into position too hard.

- o. Place assembled transmission, balance ring, and pivot dome groups on outer tub assembly.
- p. Install leg plates (11 and 12, FIGURE 2-69), align legs, and secure with assembled washer screw (10).
- q. Install grommet (13) and pressure accumulator (14).
- r. Install pressure hose (16) using hose clamp (15).

**NOTE**

Tape pressure hose (16) to outer tube near top of unit for easy access when installing later in procedure.

**CAUTION**

When reinstalling the complete tub assembly, the idler lever is in the way and can be damaged (bent), or the idler pulley could be chipped. Ensure the idler spring is disconnected and move the idler lever out of the way. This will prevent the possibility of idler lever or pulley damage.

- s. Lift complete tub (with transmission, balance ring, and pivot dome attached) and turn right side up.
- t. Lower outer tub into washer cabinet.
- u. Install centering spring (9) to notch on outer tub marked during removal.
- v. Install performed hose (16, FIGURE 2-73) with hose clamp (17, 9).
- w. Install spring (27, FIGURE 2-74) in idle lever (9).
- x. Apply a thin bead of sealant around on inside of outer tub flange.
- y. Install encased plain seal (9, FIGURE 2-70) and secure with lockwasher (8) and hexagon plain nut (7). Torque nut to 40 - 70 ft. lbs. (54.23 - 94.91 N•m).
- z. Place gasket (6) on washtub (5) after applying petroleum jelly (ensure hole alignment between tub and gasket).
- aa. Install lint filter (2) on washtub using fastener (1).
- ab. Install washtub and secure using gasket (4) and hexagon head capscrew (3).
- ac. Install cover gasket (6, FIGURE 2-69) (lubricate with liquid soap before installation).

## NOTE

Cover must be placed on outer tub so notch on top edge of outer tub cover is directly over left front clip hole in tub.

- ad. Install outer tub cover (5) and secure with spring clip (7).
- ae. Install lockwasher (2), trigger (4), and hexagon head capscrew (3).
- af. Install plug (1).
- ag. Install washer machine (1, FIGURE 2-68) cabinet top (2) as follows:

## NOTE

Ground wire must be attached to rear top flange of cabinet base before cabinet top can be secured to cabinet base.

- (1) Attach cabinet top to cabinet base (1).
- (2) Press pressure hose and base wire harness block through hole in cabinet top.
- (3) Install speed nut (9) and assembled washer screw (8).
- (4) Connect pressure hose (5) to pressure switch (6).
- (5) Connect base wire harness to control hood wire harness at quick disconnect block.
- (6) Install control panel (4) and machine screw (3).

## NOTE

Refer to paragraphs 2-84, 2-87 and 2-88 before securing front panel.

- ah. Install front panel (2, FIGURE 2-67) on washer machine (1) as follows:
  - (1) Engage front panel hold-down clips (4) in cabinet top slots.

## NOTE

Before securing front panel to cabinet base ensure that lugs are aligned with holes in front panel.

- (2) Secure front panel using machine screw (3).
- ai. Refer to paragraph 2-83.

---

2-87. Replace Washer Machine Pump and Bores Group. (FIGURE 2-73)

---

This task covers: a. Removal, b. Replacement.

---

### **INITIAL SETUP**

#### **Tools**

Tool kit, general mechanic's,  
5180-00-699-5273

#### **Equipment Condition**

Washer machine removed, para. 2-83.  
Front panel removed, para. 2-86.

---

### **REMOVAL**

- a. Remove hose clamps (9, 17) and preformed hose (16).
- b. Remove loop clamp (1), hose clamp (10), and nonmetallic hose (8) from tube to hose elbow (3).
- c. Remove machine screw (14) and bracket (13).
- d. Remove hexagon head capscrew (12) and on-sert (11).
- e. Remove centrifugal pump (15).
- f. Remove loop clamp (4) and nonmetallic hose (5).
- g. Remove hose coupling (7) and nonmetallic hose (6).

### **REPLACEMENT**

- a. Install nonmetallic hose (6) and hose coupling (7).
- b. Install nonmetallic hose (5) and loop clamp (4).
- c. Install on-sert (11), centrifugal pump (15), and hexagon head capscrew (12).
- d. Install bracket (13) and machine screw (14).
- e. Install nonmetallic hose (8), hose clamp (10) and loop clamp (1) on tube to hose elbow (3).

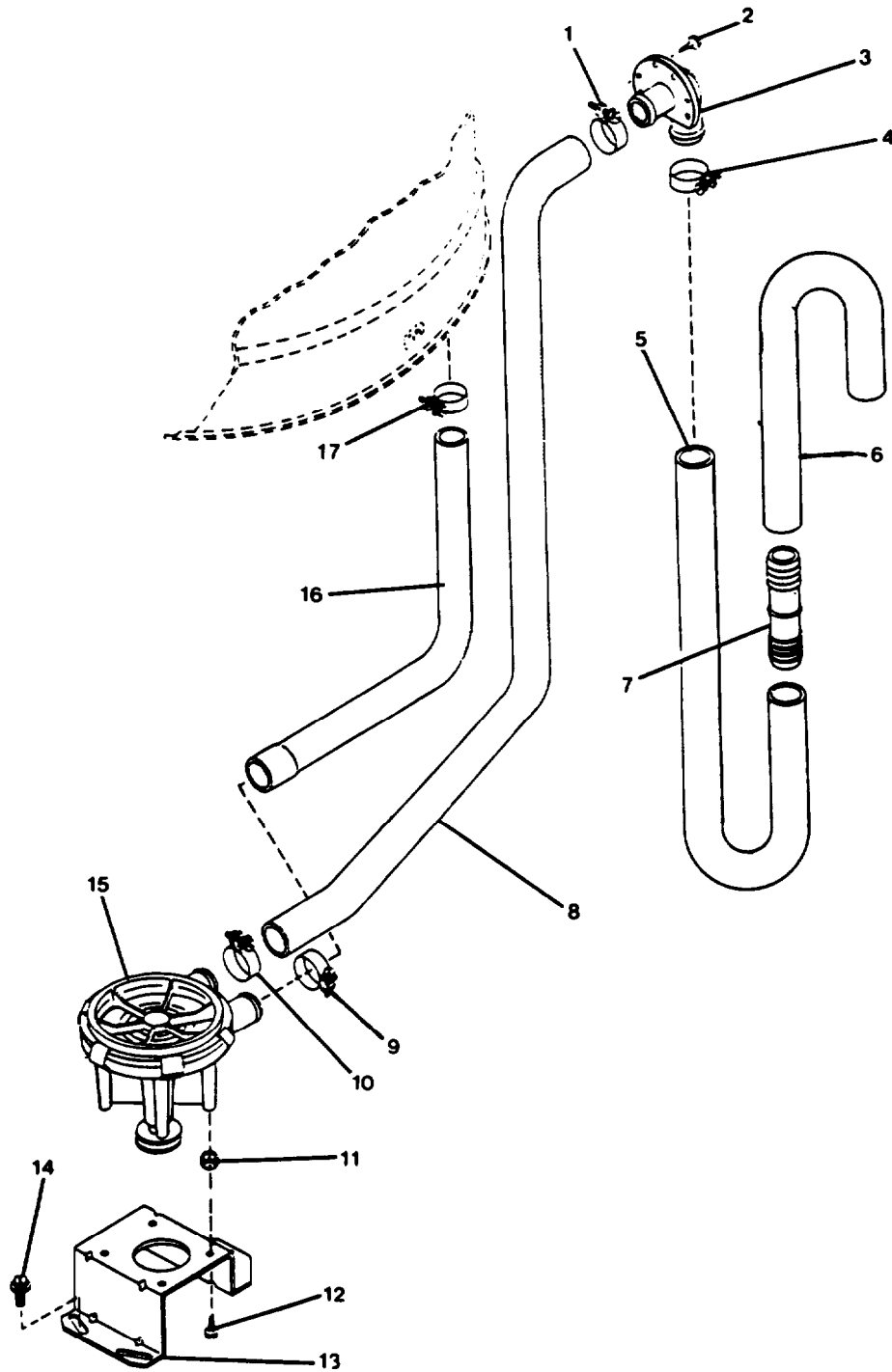


FIGURE 2-73. Washer Machine Pump and Hoses.

**NOTE**

Ensure hexhead capscrew (2) secures tube to hose elbow (3) to cabinet rear panel.

- f. Install preformed hose (16) and hose clamps (9, 17).
- g. Refer to paragraphs 2-83 and 2-86.

---

2-88. Replace Washer Machine Rotor and Idler. (FIGURE 2-74)

---

This task covers: a. Removal, b. Replacement; c. Adjustment.

---

### **INITIAL SETUP**

#### **Tools**

Tool kit, general mechanic's,  
5180-00-699-5273

#### **Equipment Condition**

Washer machine removed, para. 2-83.  
Front panel removed, para. 2-86.

#### **Materials/Parts**

V-belt P/N 27155  
V-belt P/N 28808  
Rotor P/N 27179

---

### **REMOVAL**

- a. Remove spring (27).
- b. Remove v-belt (19).
- c. Remove retaining ring (16), flat washer (15), felt washer (14), idler pulley (17), and felt washer (13).
- d. Remove locknut (8) and idler shaft (12).
- e. Remove shoulder bolt (11), flat washer (10), idler lever (10), and lock nut (7).
- f. Remove hexagon head capscrew (25).
- g. Remove machine screw (29) and motor bracket (28).
- h. Remove V-belt (18).
- i. Remove ground clip (20) and wire clip (26).
- j. Remove locknut (21), flat washer (22), resilient mount (23) and spacer (24).
- k. Remove motor (3).
- l. Remove resilient motor mount (30) and flat washer (31).
- m. Remove headless straight pin (6) and motor pulley (32).
- n. Remove spring pin (5) and motor pulley (4).

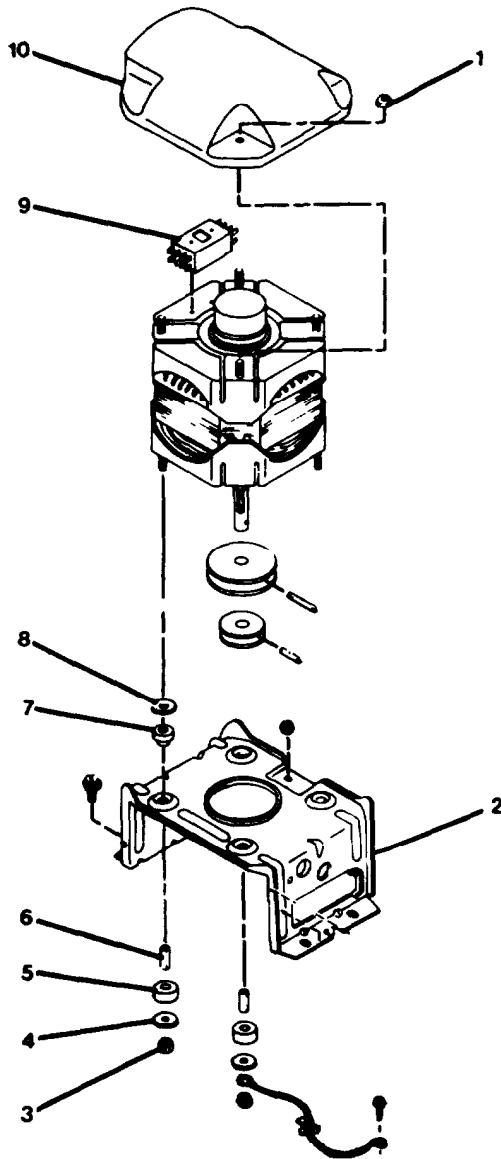


FIGURE 2-74. Washer Motor and Idler.



- o. Remove locknut (2) and motor shield (1).
- p. Remove push switch (33).

#### REPLACEMENT

- a. Install push switch (33).
- b. Install motor shield (1) and locknut (2).
- c. Install motor pulley (4) and spring pin (5).
- d. Install motor pulley (32) and headless straight pin (6).
- e. Install resilient motor mount (30) and flat washer (31).
- f. Install motor (3).
- g. Install spacer (24), resilient mount (23), flat washer (22), and locknut (21).
- h. Install ground clip (20) and wire clip (26).
- i. Install motor bracket (28) and machine screw (29).

#### NOTE

Do not tighten machine screw (29) until V-belt (18) is installed.

- j. Install V-belt (18).
- k. Install hexagon head capscrew (25).
- l. Install idler lever (9), flat washer (10), shoulder bolt (11), and lock nut (7).
- m. Install idler shaft (12) and locknut (8).
- n. Install felt washer (13), idler pulley (17), felt washer (14), flat washer (15), and retaining ring (16).
- o. Install V-belt (19).
- p. Install spring (27).
- q. Refer to paragraphs 2-83 and 2-86.

#### ADJUSTMENT

- a. To adjust V-belt (18) perform the following:

NOTE

Adjustment must be made after motor (3) has been properly positioned to limit of travel to rear of washer within mounting bracket (28) attaching screws (29).

- (1) Loosen two front pump mounting screws (14, FIGURE 2-73), then loosen rear mounting screw.
- (2) Shift front of pump mounting bracket (13) to right or left to obtain proper belt tension.

NOTE

Proper tension is when belt can be deflected approximately 1/2 inch (12.7 mm) from normal position with moderate pressure (1 1/2 pounds (.675 Kg) at a point midway between pulleys).

- (3) Tighten three mounting screws (14).

---

2-89. Replace Laundry Dryer Tumbler. (FIGURE 2-75)

---

This task covers: a. Removal, b. Repair, c. Replacement.

---

### INITIAL SETUP

#### Tools

Tool kit, general mechanic's,  
5180-00-699-5273  
Tool kit, electrician's,  
5180-00-391-1087

#### Equipment Condition

Electrical power turned OFF at galley  
240V power panel. Switch tagged "Out  
of Service - Do Not Operate."

#### Materials/Parts

Laundry dryer tumbler  
P/N SE-4732  
Warning tags, Item 1, Appendix C

---

### REMOVAL

- a. Unplug dryer power cord.
- b. Remove machine bolts (3), lockwasher (2), and plain hexagon nut (1).
- c. Remove dryer vent tube.
- d. Remove laundry dryer tumbler.

### REPLACEMENT

- a. Install laundry dryer tumbler.
- b. Install dryer vent tube.
- c. Install machine bolt (3), lockwasher (2), and plain hexagon nut (1).
- d. Plug in dryer power cord.
- e. Remove tag and turn on electrical power at galley 240V power panel.

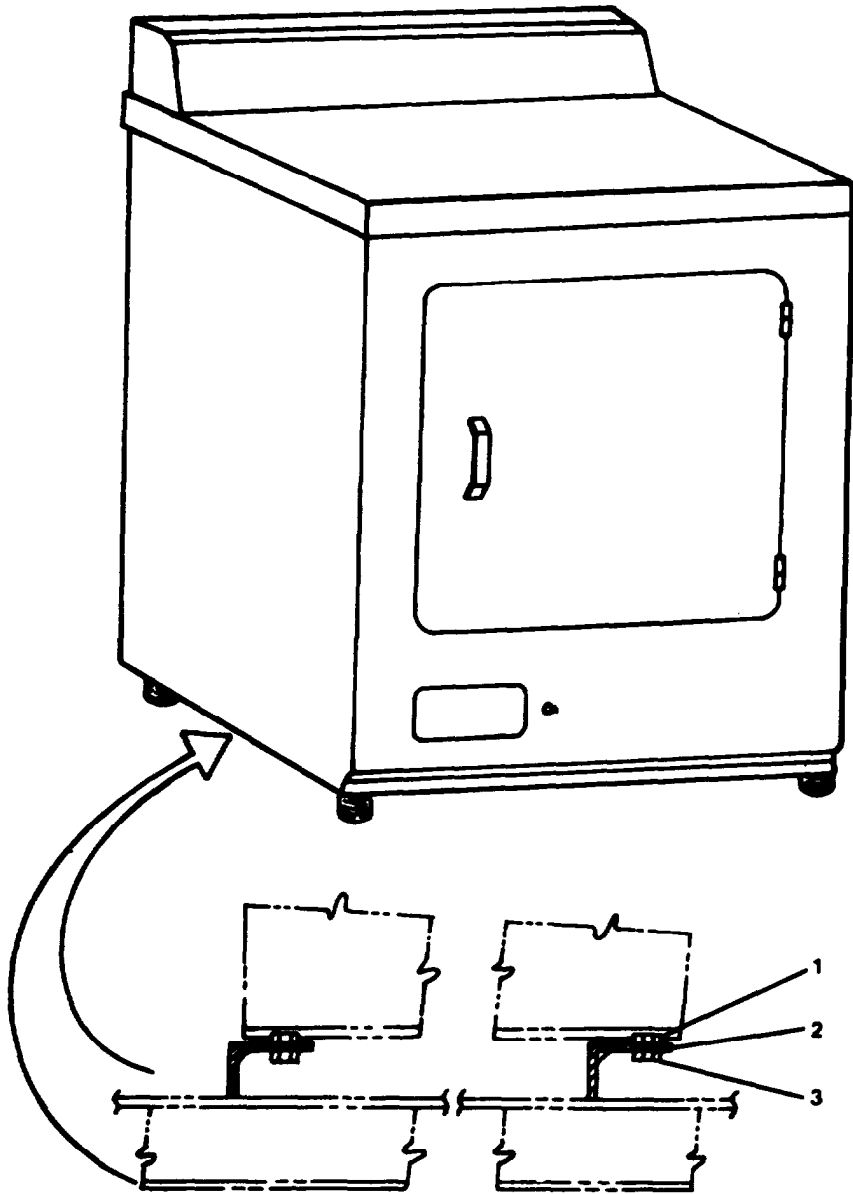


FIGURE 2-75. Replace Laundry Dryer Tumbler.

---

2-90. Replace Dryer Front Bulkhead and Cylinder Assembly. (FIGURE 2-76)

---

This task covers: a. Removal, b. Replacement.

---

### **INITIAL SETUP**

#### **Tools**

Tool kit, general mechanic's,  
5180-00-699-5273

#### **Equipment Condition**

Dryer removed, para 2-89.

#### **Materials/Parts**

Dryer front bulkhead and cylinder  
assembly P/N F16429 RPSTL

---

### **REMOVAL**

- a. Remove machine screw (9, Sheet 1) and flat washer (8).
- b. Remove access door (10).
- c. Remove support rivet (11).
- d. Remove hexagon head capscrew (7).
- e. Remove machine screw (1) and sleeve bushing (2).
- f. Remove hold-down clip (3).
- g. Remove machine screw (13) and sleeve bushing (12).
- h. Remove dryer front panel (6).
- i. Remove seal (5).
- j. Remove switch (4).
- k. Remove machine screw (14, Sheet 2) and lint filter (15).
- l. Remove hexagon head capscrews (25 and 27).
- m. Remove dryer air-duct (26).
- n. Remove bumper (28).
- o. Remove hexagon head capscrew (22), cylinder guide (23), and felt pad (24).

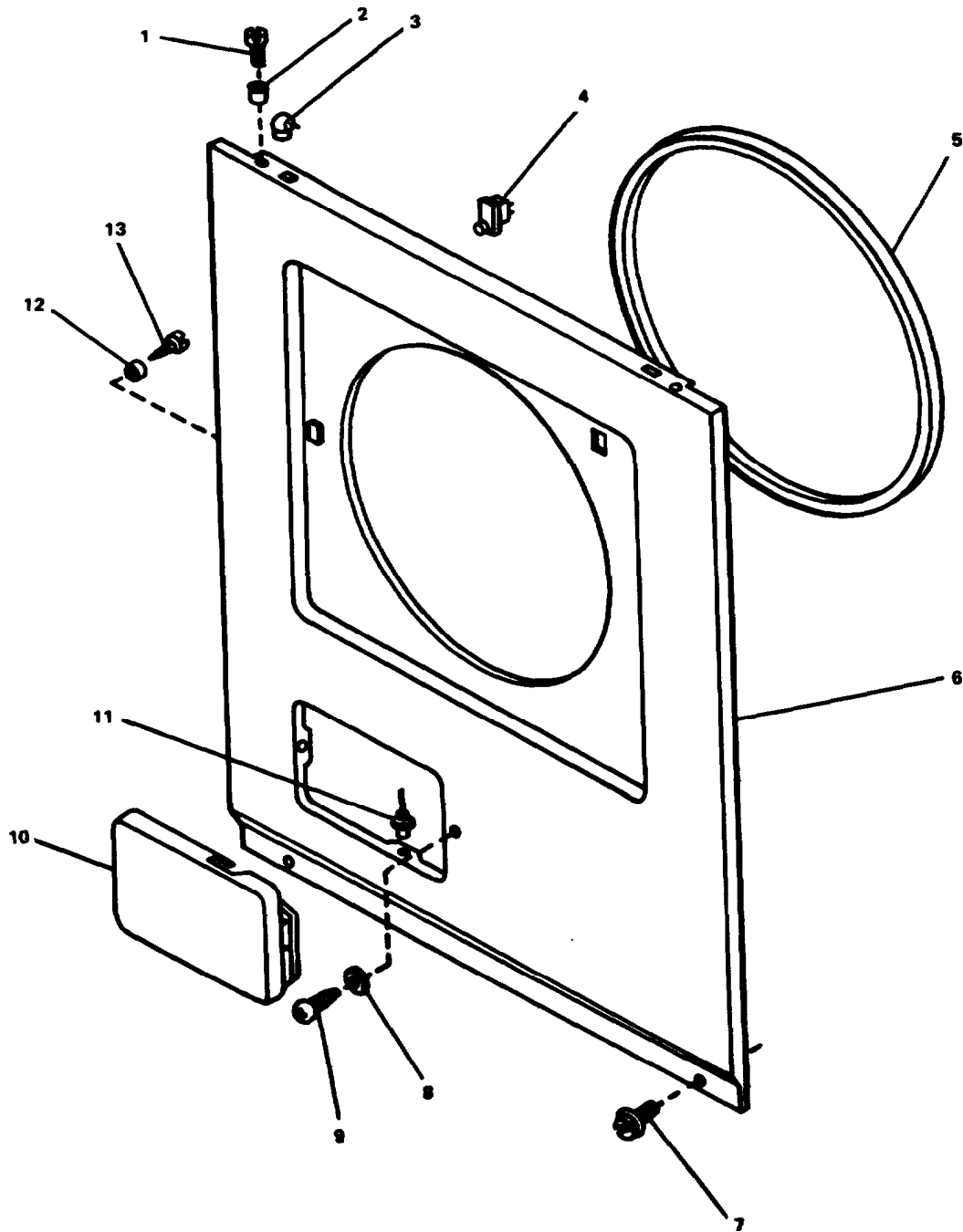


FIGURE 2-76. Dryer Front Bulkhead and Cylinder Assembly (Sheet 1 of 2).

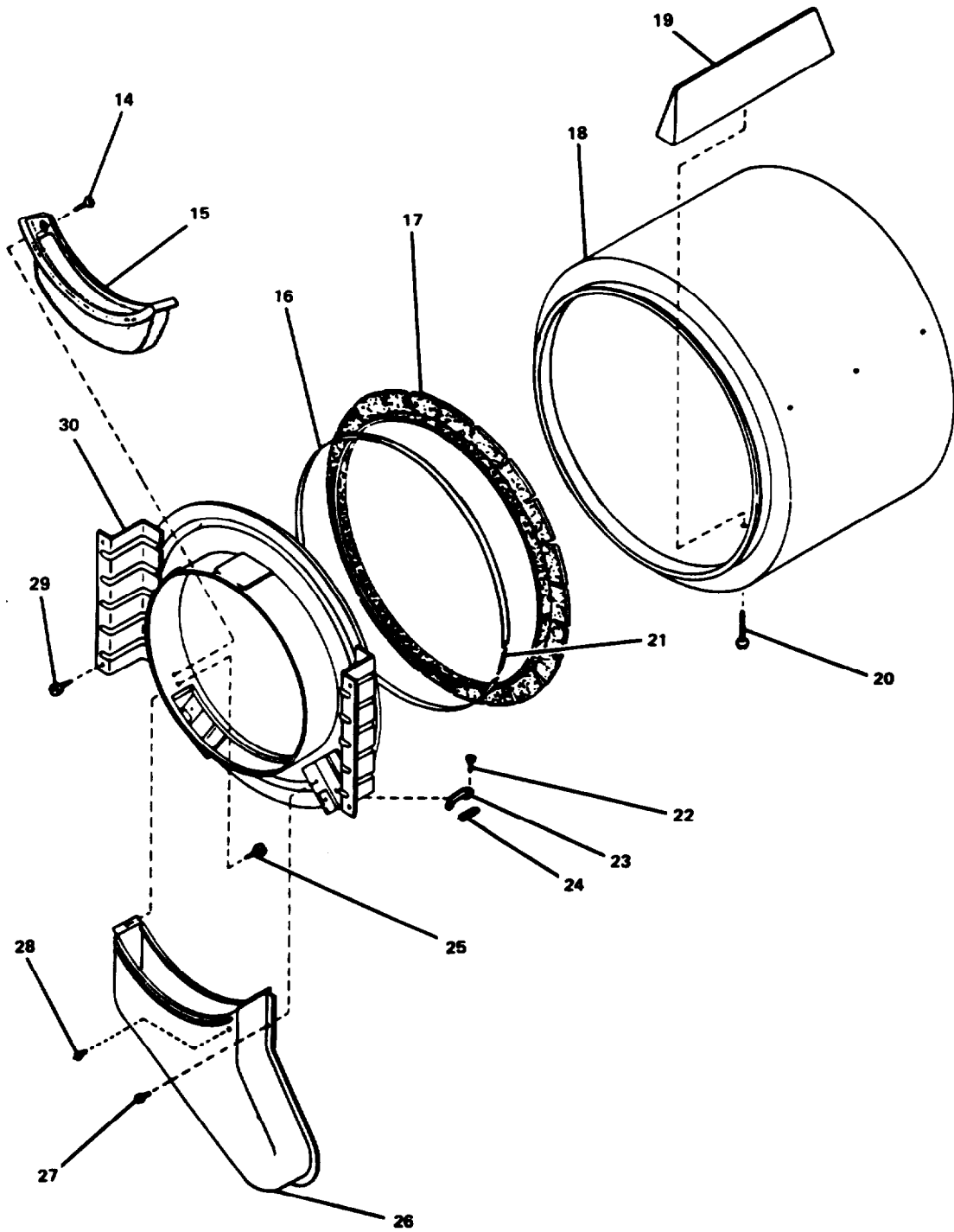


FIGURE 2-76. Dryer Front Bulkhead and Cylinder Assembly (Sheet 2 of 2).

- p. Refer to paragraph 2-93 for V-belt removal.
- q. Remove hexagon head capscrew (29).
- r. Remove front bulkhead (30).
- s. Remove spring (21), retaining strap (16), and seal (17).
- t. Remove hexagon head capscrew (20) and dryer cylinder baffle (19).
- u. Remove cylinder assembly (18).

## **REPLACEMENT**

- a. Install cylinder assembly (13).
- b. Install dryer cylinder baffle (19) and hexagon head capscrew (20).
- c. Install seal (17), retaining strap (16), and spring (21).
- d. Install front bulkhead (30).
- e. Install hexagon head capscrew (29).
- f. Refer to paragraph 2-93 for V-belt installation.
- g. Install felt pad (24), cylinder guide (23), and hexagon head capscrew (22).
- h. Install bumper (28).
- i. Install dryer air-duct (26).
- j. Install hexagon head capscrews (25 and 27).
- k. Install lint filter (15) and machine screw (4).
- l. Install switch (4, Sheet 1).
- m. Install seal (5).
- n. Install dryer front panel (6).
- o. Install sleeve bushing (12) and machine screw (13).
- p. Install hold-down clip (3).
- q. Install sleeve bushing (2) and machine screw (1).
- r. Install hexagon head capscrew (7).
- s. Install support rivet (11).
- t. Install access door (10).
- u. Install flat washer (8) and machine screw (9).



- v. Refer to paragraph 2-89 for dryer replacement.

---

2-91. Replace Dryer Rear Bulkhead and Cylinder Roller Group. (FIGURE 2-77)

---

This task covers: a. Removal, b. Replacement.

---

### **INITIAL SETUP**

#### **Tools**

Tool kit, general mechanic's,  
5180-00-699-5273

#### **Equipment Condition**

Dryer removed, para. 2-89.  
Cylinder assembly removed, para. 2-90.  
Heater element removed, para. 2-92.

---

### **REMOVAL**

- a. Remove spring (19) and retaining strap (2).
- b. Remove seal (1).
- c. Remove retaining ring (17), flat washers (18), roller (16), and thrust washer (15).
- d. Remove locknut (20) and bolt (14).
- e. Remove bolt (11), flat washer (12), and roller (13).

#### NOTE

Hexhead screw (6, FIGURE 2-78) must be removed prior to removal of rear bulkhead and heater box.

- f. Remove machine screws (4, 10) and dryer rear bulkhead (3) and attached heater box.

#### NOTE

Refer to paragraph 2-92 to remove heater box from dryer rear bulkhead.

- g. Remove hexagon head capscrews (6, 7) and cupped washer (8).
- h. Remove dryer bulkhead (9) bracket.
- i. Remove hexagon head capscrew (22, Sheet 2) and bracket (5, Sheet 1).

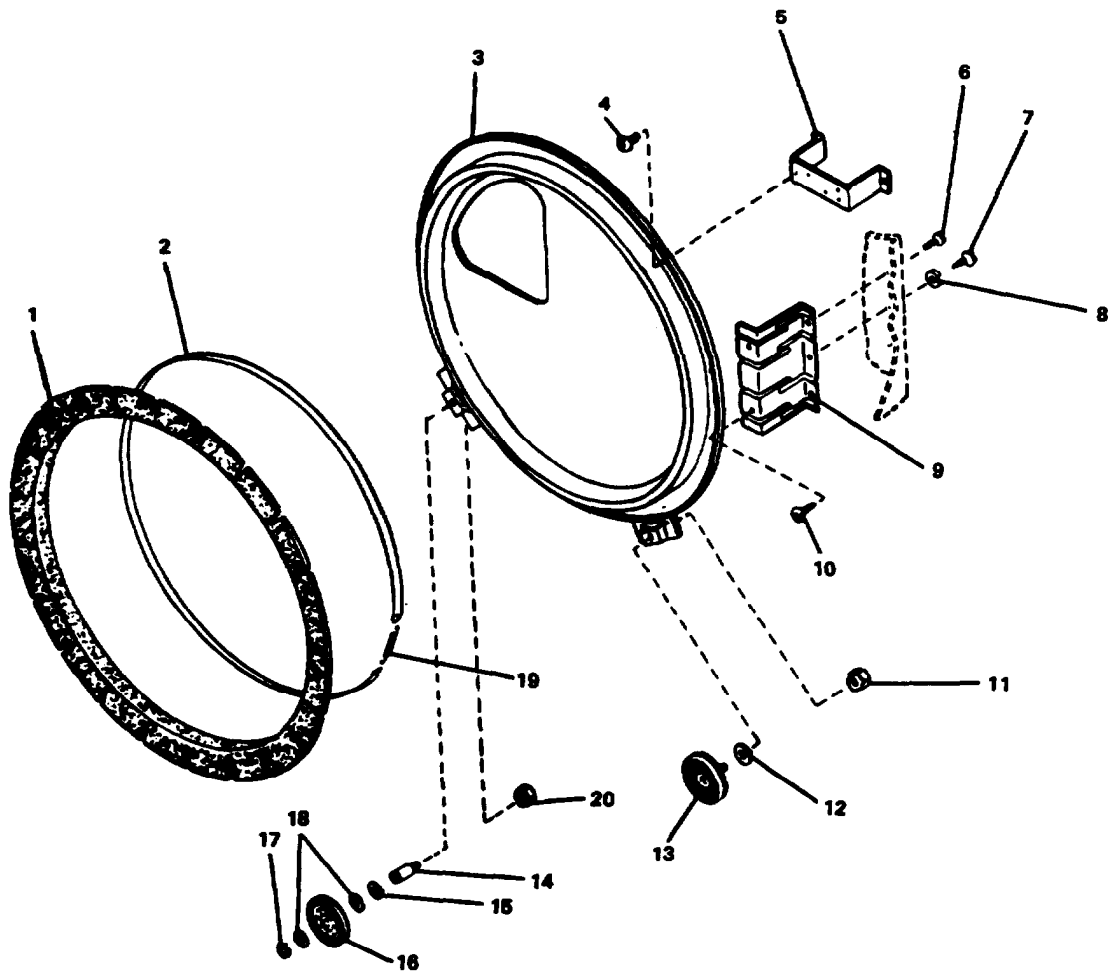


FIGURE 2-77. Dryer Rear Bulkhead and Cylinder Roller Group (Sheet 1 of 2).

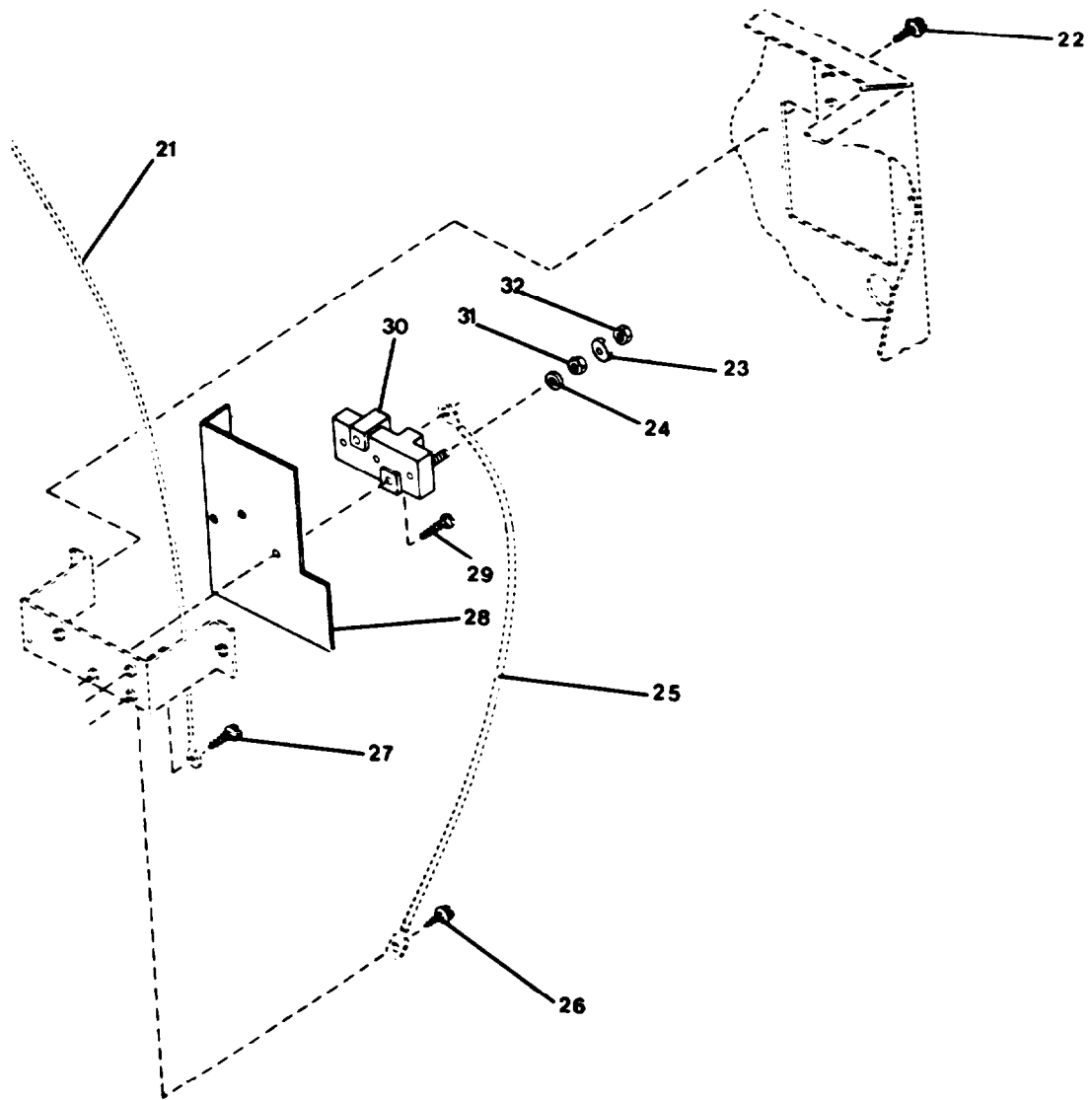


FIGURE 2-77. Dryer Rear Bulkhead and Cylinder Roller Group (Sheet 2 of 2).

- j. Remove machine screw (29, Sheet 2), terminal board (30) and terminal board cover (28).
- k. Remove hexagon head capscrew (26, 27) and remove ground wires (21, 25).
- l. Remove plain hexagon nuts (32), cupped washer (23), plain hexagon nut (31) and flat washer (24).

### **REPLACEMENT**

- a. Install flat washer (24), plain hexagon nut (31), cupped washer (23), and plain hexagon nut (32).
- b. Install ground wires (21, 25) and hexagon head capscrews (26, 27).
- c. Install terminal board cover (28), terminal board (30), and machine screw (29).
- d. Install bracket (5) and hexagon head capscrew (22).
- e. Install dryer bulkhead (9).
- f. Install cupper washer (8) and hexagon head capscrews (6, 7).

### NOTE

The heater box must be installed on the dryer rear bulkhead prior to installation in cabinet, refer to paragraph 2-92.

- g. Install dryer rear bulkhead (3) and machine screws (4, 10).
- h. Install roller (13), flat washer (12) and bolt (11).
- i. Install bolt (14) and locknut (20).
- j. Install thrust washer (15), roller (16), flat washer (18), and retaining ring (17).
- k. Install seal (1).
- l. Install retaining strap (2) and spring (19).
- m. Refer to paragraphs 2-89, 2-90, and 2-92.

---

2-92. Replace Dryer Heater Box Group. (FIGURE 2-78)

---

This task covers: a. Removal, b. Replacement.

---

INITIAL SETUP

Tools

Tool kit, general mechanic's,  
5180-00-699-5273  
Tool kit, electrician's,  
5180-00-391-1087

Equipment Condition

Dryer removed, para. 2-89.  
Cylinder assembly removed, para. 2-90.  
Dryer rear bulkhead removed,  
para. 2-91.

Materials/Parts

Warning tags, Item 1, Appendix C

---

REMOVAL

- a. Remove hexagon head capscrew (15).
- b. Remove hexagon head capscrew (14).
- c. Tag and disconnect electrical leads and remove thermostatic switch (13) from mounting plate.
- d. Remove mounting plate and attached heater element (22) from heater box (1).

NOTE

Pull mounting plate down and away from heater box to remove.

- e. Remove hexagon head capscrew (6).

NOTE

These capscrews must be removed prior to heater box and dryer rear bulkhead removal from the cabinet.

- f. Remove nuts, (12, 16), flat washers (11, 17), nuts (10, 18), flat washers (9, 19), and bushing insulators (8, 20).
- g. Remove bushing insulators (7, 21).
- h. Remove electric heater element (22) from mounting plate.

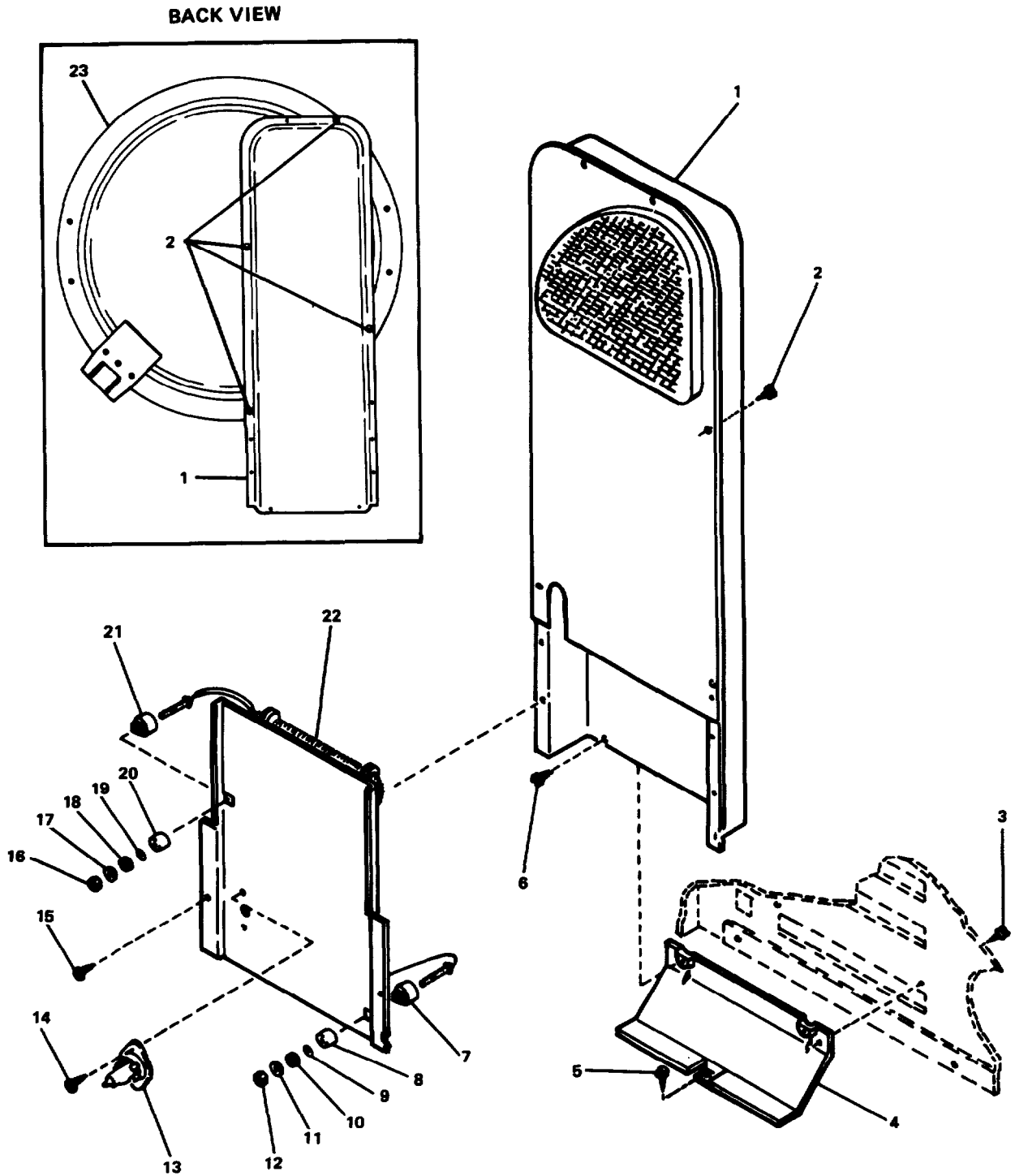


FIGURE 2-78. Dryer Heater Box Group.

- i. Remove hexagon head capscrew (2) retaining heater box to rear bulkhead (23).
- j. Remove dryer heater box (1).
- k. Remove hexagon head capscrews (3, 5).
- l. Remove heat shield (4).

**REPLACEMENT**

- a. Install heat shield (4).
- b. Install hexagon head capscrews (3, 5).

NOTE

The dryer heater box must be installed on the dryer rear bulkhead prior to installation in cabinet.

- c. Install hexagon head capscrews (2) retaining heater box to rear bulkhead.
- d. Install dryer heater box (1) and rear bulkhead (23).
- e. Refer to paragraph 2-91 for dryer rear bulkhead replacement.
- f. Install hexagon head capscrew (6).
- g. Install electric heater element (22) on mounting plate.
- h. Install bushing insulators (7, 21).
- i. Install bushing insulators (8, 20), flat washers (9, 19), nuts (10, 18), flat washers (11, 17), and nuts (12, 16).
- j. Install mounting plate and attached heater element (22) on heater box (1).

NOTE

Rush mounting plate up and into heat box to install.

- k. Install thermostatic switch (13) and remove tags and connect electrical leads.
- l. Install hexagon head capscrew (14).
- m. Install hexagon head capscrew (15).
- n. Refer to paragraphs 2-90 and 2-89.



---

2-93. Replace Dryer Motor and Exhaust Fan Group. (FIGURE 2-79)

---

This task covers: a. Removal, b. Replacement.

---

### INITIAL SETUP

#### Tools

Tool kit, general mechanic's,  
5180-00-699-5273  
Tool kit, electrician's,  
5180-00-391-1087

#### Equipment Condition

Dryer removed, para. 2-89.  
Dryer front panel and air duct  
removed, para. 2-90.

#### Materials/Parts

Warning tags, Item 1, Appendix C

---

### REMOVAL

- a. Remove V-belt (2).
- b. Remove set screw (4) and groove pulley (3).
- c. Remove seal (23).
- d. Remove hexagon head capscrew (24, 30).
- e. Remove exhaust fan cover (31).
- f. Tag and disconnect electrical leads.
- g. Remove hexagon head capscrew (25) and thermostatic switch (22).
- h. Remove hexagon head capscrew (26) and high thermostatic switch (27).
- i. Remove hexagon head capscrew (28) and low limit thermostatic switch (29).
- j. Remove centrifugal impeller fan (21).

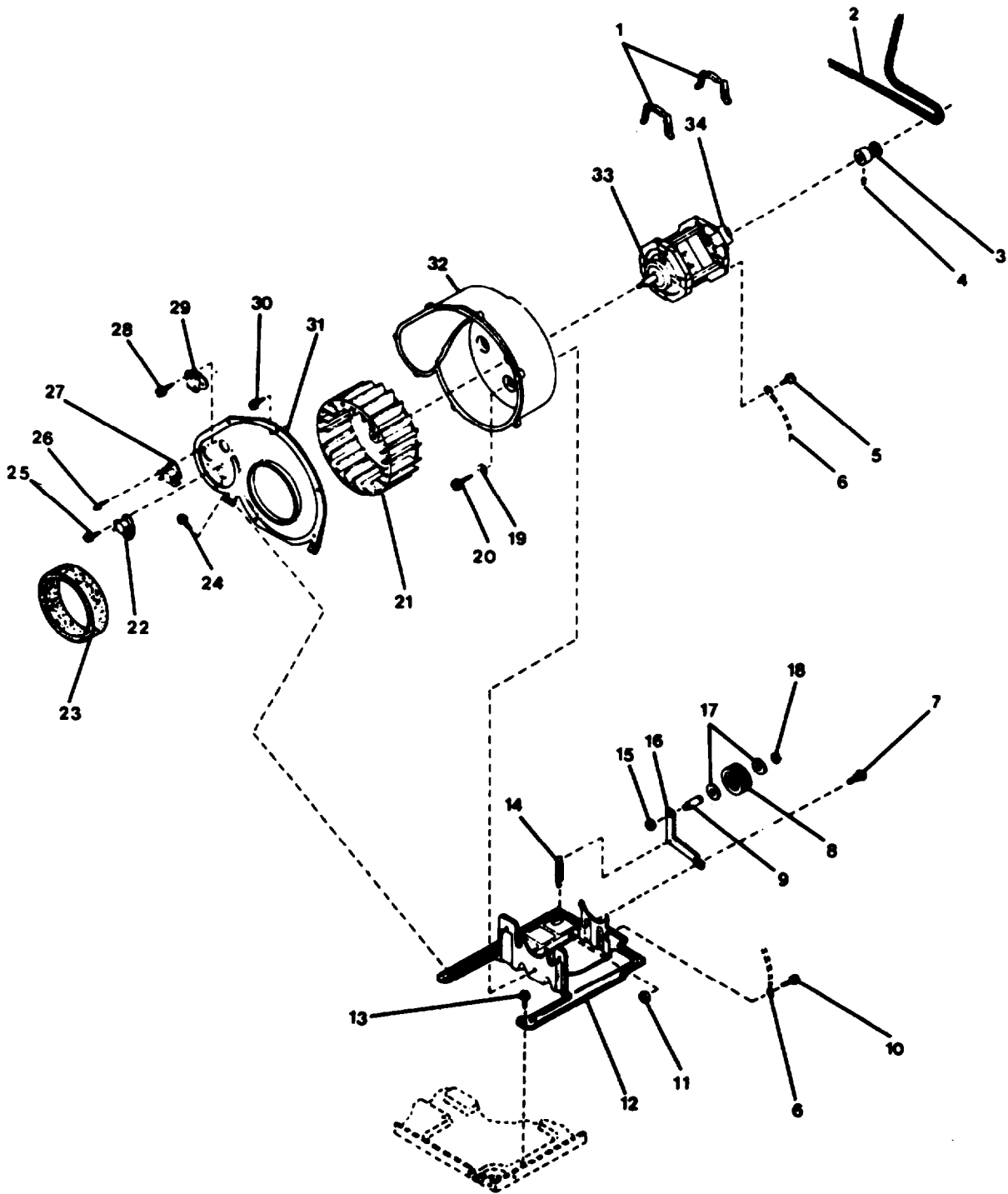


FIGURE 2-79. Repair Dryer Motor and Exhaust Fan Group.

- k. Remove motor clips (1).
- l. Remove hexagon head capscrews (5, 10) and ground wire (6).
- m. Remove motor (33).
- n. Remove switch (34).
- o. Tag and disconnect electrical leads internal to switch (34).
- p. Remove hexagon head capscrews (20) and washer (19).
- q. Remove dryer fan housing (32).
- r. Remove spring (14).
- s. Remove retaining ring (18), flat washers (17), and groove pulley (8).
- t. Remove locknut (15) and bolt (9).
- u. Remove locknut (11) and shoulder bolt (7).
- v. Remove idler lever (16).
- w. Remove hexagon head capscrew (13).
- x. Remove motor mounting bracket (12).

#### **REPLACEMENT**

- a. Install motor mounting bracket (12).
- b. Install hexagon head capscrew (13).
- c. Install idler level (16).
- d. Install shoulder bolt (7) and locknut (11).
- e. Install bolt (9) and locknut (15).
- f. Install groove pulley (8), flat washers (17), and retaining ring (18).
- g. Install spring (14).
- h. Install dryer fan housing (32).
- i. Install washer (19) and hexagon head capscrew (20).
- j. Remove tags and install electrical leads for switch (34) internal to motor (33).
- k. Install switch (34).
- l. Install motor (33).

- m. Install ground wire (6) and hexagon head capscrews (5, 10).
- n. Install motor clips (1).
- o. Install centrifugal impeller fan (21).
- p. Install low limit thermostatic switch (29) and hexagon head capscrew (28).
- q. Install high thermostatic switch (27) and hexagon head capscrew (26).
- r. Install thermostatic switch (22) and hexagon head capscrew (25).
- s. Remove tags and connect electrical leads.
- t. Install exhaust fan cover (31).
- u. Install hexagon head capscrews (24, 30).
- v. Install seal (23).
- w. Install groove pulley (3) and setscrew (4).
- x. Install V-belt (2).
- y. Refer to paragraphs 2-90 and 2-89.

---

2-94. Replace Dryer Cabinet, Exhaust Duct, and Base Group. (FIGURE 2-80)

---

This task covers: a. Removal, b. Replacement.

---

### INITIAL SETUP

#### Tools

Tool kit, general mechanic's,  
5180-00-699-5273

#### Equipment Condition

Dryer removed, para. 2-89.  
Dryer front bulkhead and cylinder  
assembly removed, para. 2-90.  
Dryer rear bulkhead and cylinder roller  
group removed, para. 2-91.  
Dryer heater box group removed, para.  
-2-92.  
Dryer motor and exhaust fan group  
removed, para. 2-93.

---

### REMOVAL

- a. Remove the front panel, refer to paragraph 2-90.
- b. To remove the control panel perform the following:
  - (1) Loosen set screw and remove knob (1) and knurled nut (2) from temperature switch (5) shaft.
  - (2) Remove machine screw (3) and speed nut (6).
  - (3) Partially remove control panel (9).
  - (4) Tag and disconnect electrical leads from switches (5 and 8) and indicator light (10).
  - (5) Remove lock washer (4) from temperature switch shaft.
  - (6) Remove control panel (9) from dryer unit.
- c. Tag and disconnect all electrical leads to components in control hood (7), and ground wire (13, Sheet 2) after removing hex head cap screw (12).
- d. Remove electrical lead wiring harness by pushing through opening in cabinet top (14).
- e. Remove cabinet top washer screws (15) and speed nuts (16) in front corners of unit.

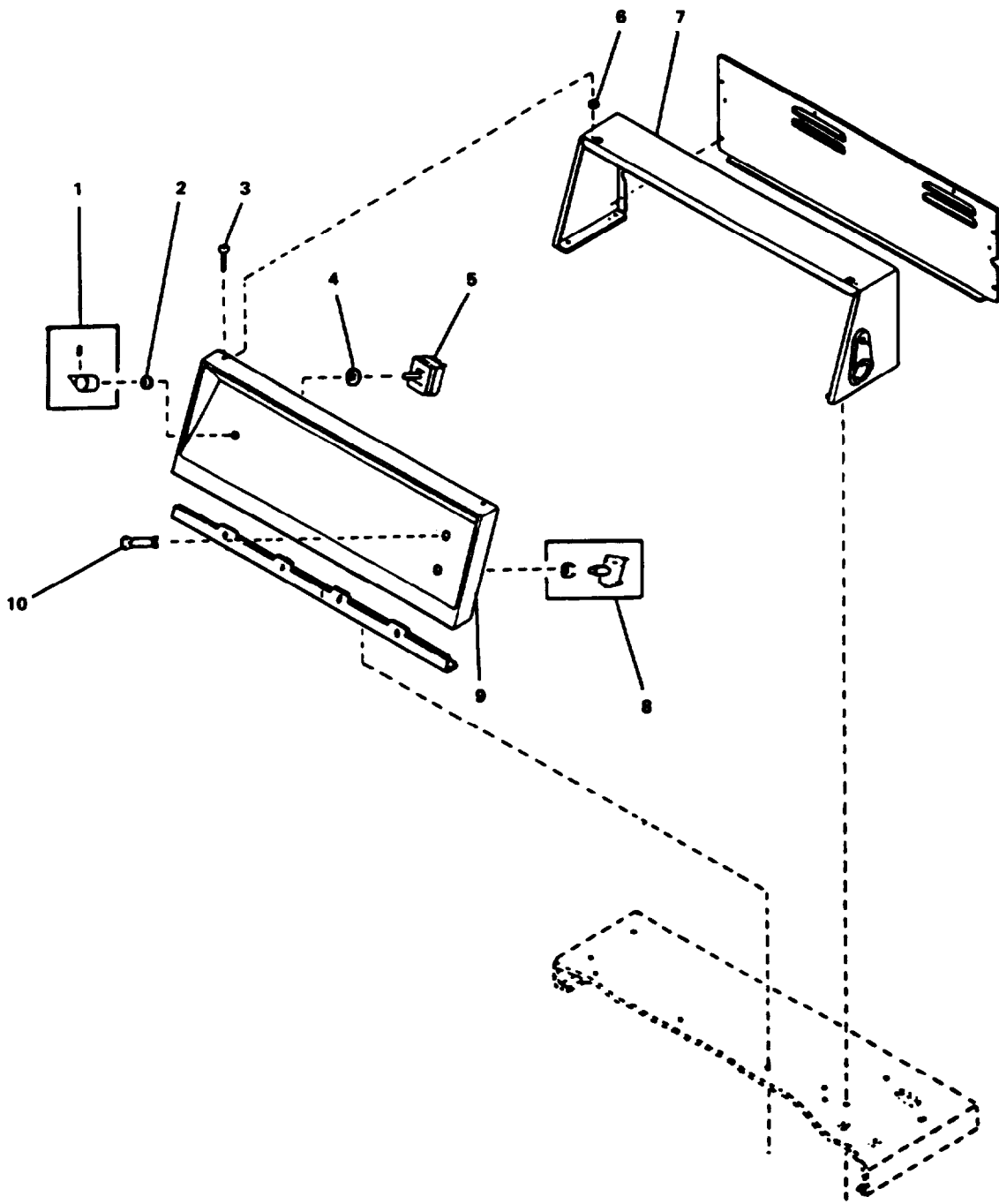


FIGURE 2-81. Dryer Cabinet, Exhaust Duct and Base Group (Sheet 1 of 3).

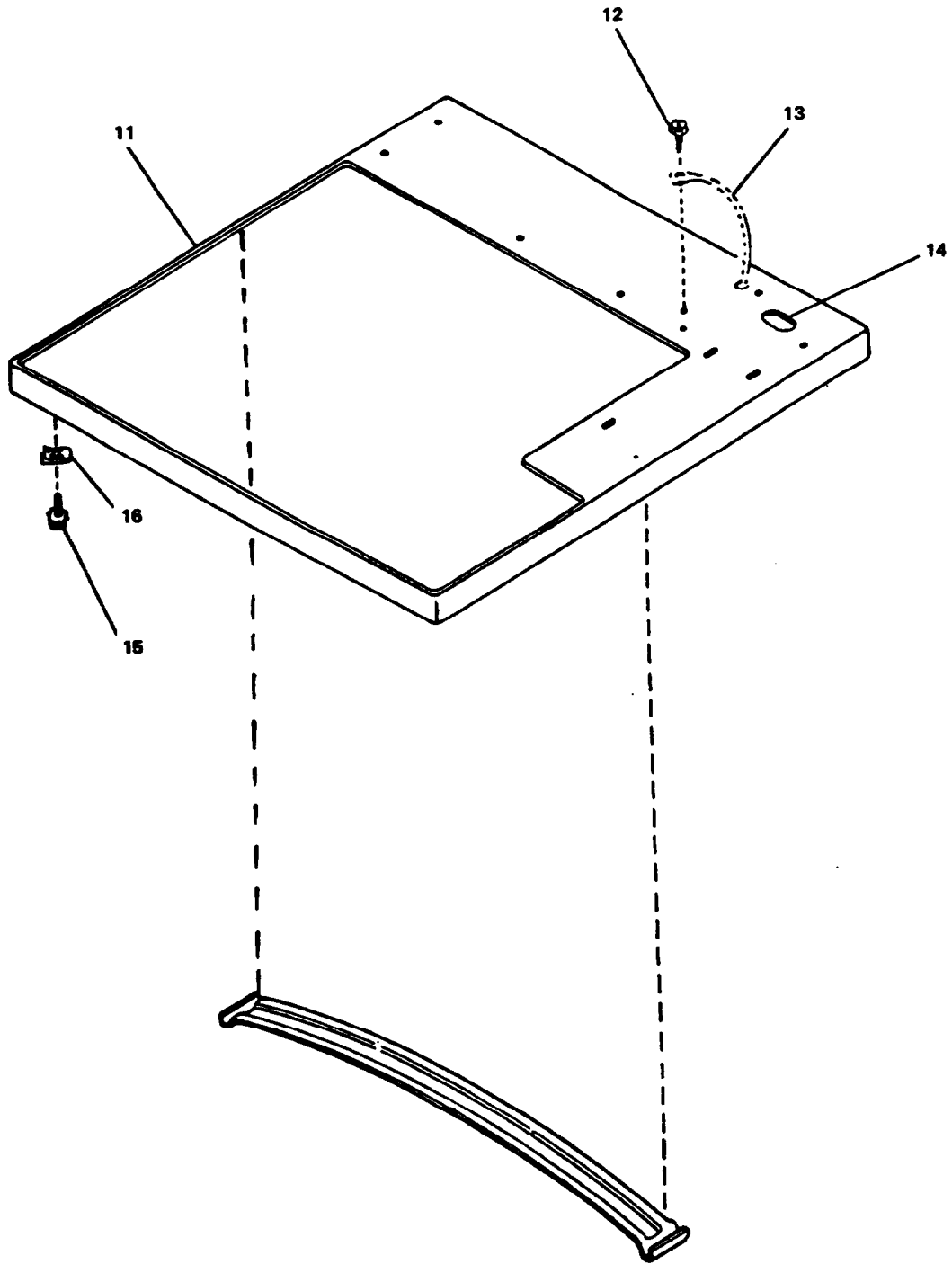


FIGURE 2-81. Dryer Cabinet Exhaust Duct and Base Group (Sheet 2 of 3).

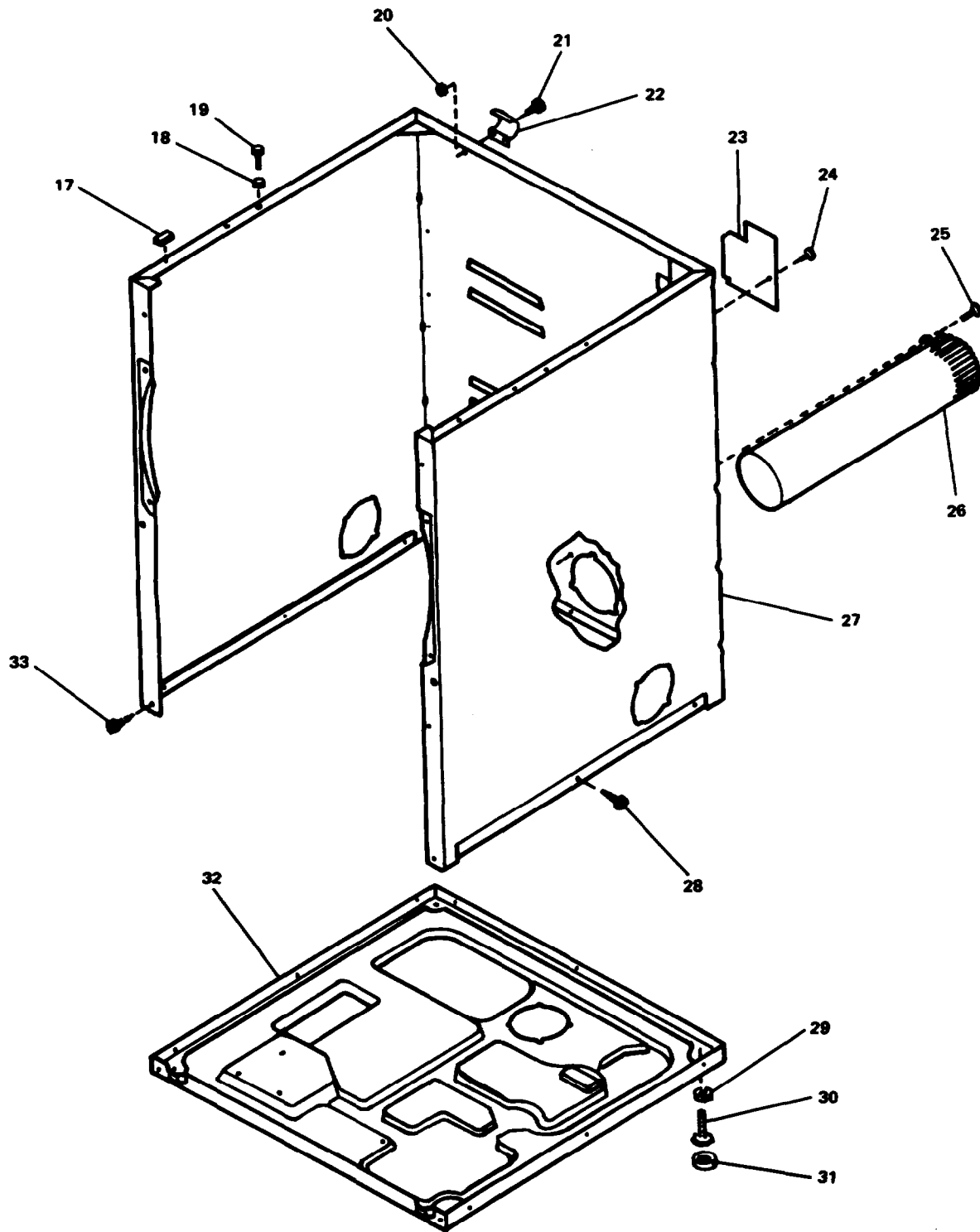


FIGURE 2-81. Dryer Cabinet, Exhaust Duct and Base Group (Sheet 3 of 3).



- f. Lift front of cabinet top (11), disengage from hinges (22, Sheet 3) and remove cabinet top and attached control hood.
- g. Remove front bulkhead and cylinder assembly, refer to paragraph 2-90.
- h. Remove motor and exhaust fan group, refer to paragraph 2-93.
- i. Remove rear bulkhead and heater box (including heat shield), refer to paragraphs 2-91 and 2-92, respectively.
- j. Remove pad (17).
- k. Remove machine screw (19) and sleeve bushing (18).
- l. Remove hexagon head capscrew (21), locknut (20), and hinge (22).
- m. Remove hexagon head capscrew (24) and access plate (23).
- n. Remove hexagon head capscrew (25) and dryer exhaust duct (26).
- o. Remove hexagon head capscrews (28, 33).
- p. Remove cabinet (27) from base (32).
- q. Remove rubber pad (31), leveling leg (30), and hexagon plain nut (29).

#### **ASSEMBLY**

- a. Install hexagon plain nut (29), leveling leg (30), and rubber pad (31) on base (32).
- b. Install cabinet (27) on base.
- c. Install hexagon head capscrews (28, 33).
- d. Install exhaust duct (26) and hexagon head capscrew (25).
- e. Install access plate (23) and hexagon head capscrew (24).
- f. Install hinge (22), locknut (20), and hexagon head capscrew (21).
- g. Install sleeve bushing (18) and machine screw (19).
- h. Install pad (17).
- i. Refer to paragraphs 2-89.
- j. Install heater box (including heat shield) and rear bulkhead, refer to paragraphs 2-92 and 2-91, respectively.
- k. Install motor and exhaust fan group, refer to paragraph 2-93.
- l. Install front bulkhead and cylinder assembly, refer to paragraph 2-90.

- m. Install cabinet top (11, Sheet 2) and attached control hood engaging hinges (22, Sheet 3) before lowering onto cabinet (27).
- n. Install cabinet top (11, Sheet 2) washer screws (15) and speed nuts (16) in front corners of unit.
- o. Install electrical lead wiring harness by pushing up through opening in cabinet top (14).
- p. Remove tags and reconnect all electrical leads to components in control hood (7, Sheet 1) and ground wire (13, Sheet 2) with screw (12).
- q. To install control panel (9) perform the following:
  - (1) Remove tags and connect electrical leads to temperature switch (5), switch (8) and indicator light (10).
  - (2) Install lock washer (4) on temperature switch shaft.
  - (3) Install temperature switch in control panel (9) and retain with knurled nut (2).
- r. Install control panel, speed nut (6), and machine screw (3).
- s. Install knob (1) on temperature switch (5) shaft and tighten set screw.
- t. Install the dryer front panel, refer to paragraph 2-90.

MAINTENANCE OF MISCELLANEOUS PUMPS AND MOTORS
---

---

2-95. Replace/Repair Centrifugal Pump Unit (Fresh Water). (FIGURE 2-81)

---

This task covers: a. Removal, b. Repair, c. Replacement.

---

### INITIAL SETUP

#### Tools

Tool kit, general mechanic's,  
5180-00-699-5273  
Tool kit, electrician's,  
5180-00-391-1087

#### Equipment Condition

Electrical power to pump unit turned  
OFF at ships service switchboard and  
tagged "Out of Service - Do Not  
Operate."

#### Materials/Parts

Centrifugal pump unit P/N 330CS9M-AB-SP  
A/C Motor P/N 23255F  
Warning tags, Item 1, Appendix C

---

### REMOVAL

- a. Tag and disconnect electrical leads at junction box on motor.
- b. Close pump suction (12) and discharge (1) valves.
- c. Remove insulating material from unions at inlet and outlet sides of pump.
- d. Disconnect discharge piping at union (2) located on top of pump.
- e. Disconnect suction piping at union (11) on inlet side of pump.
- f. Remove four plain hex nuts (9), lockwashers (8), washers (7) and hexhead capscrews (6) securing motor (5) to foundation.
- g. Remove pump (4) and motors (5).
- h. Remove pipe nipples (3) and (10) from pump.

### REPAIR

Repair of centrifugal pump unit consists of replacing pump (4), motor (5).

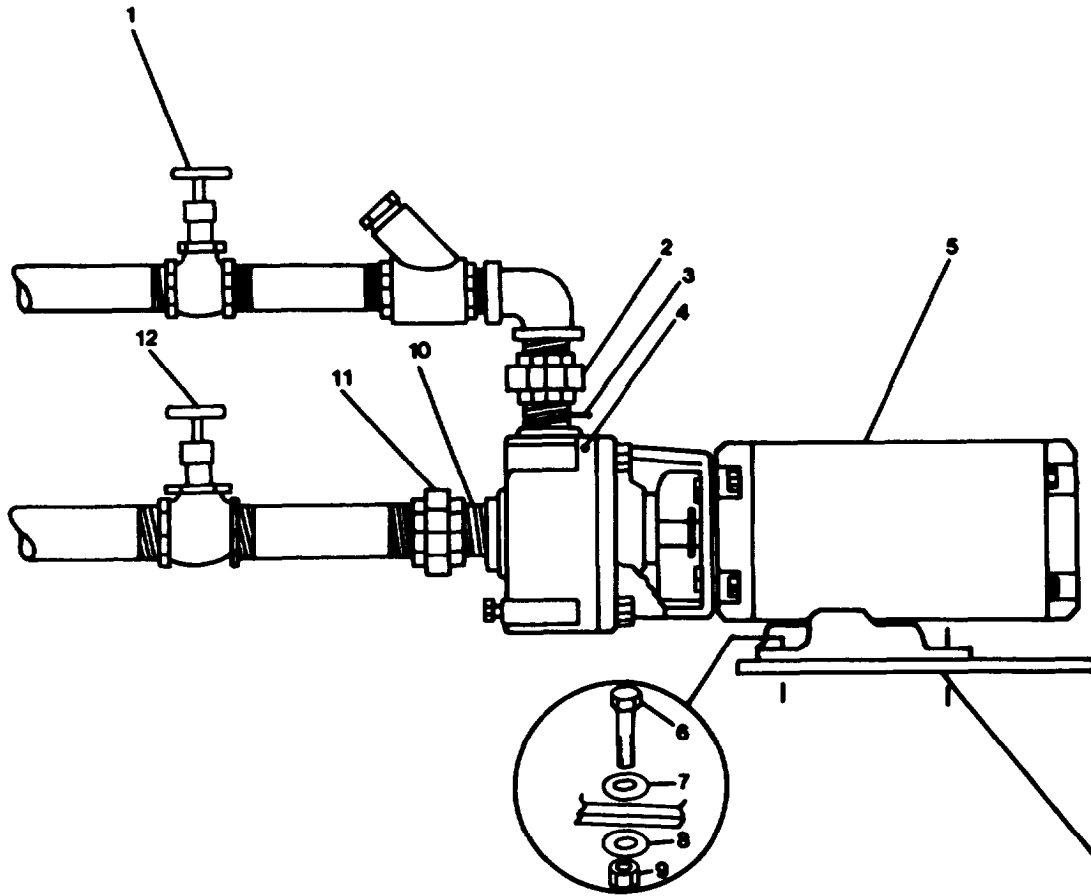


FIGURE 2-81. Centrifugal Pump Unit (Fresh Water).

**REPLACEMENT**

- a. Install nipples (3) and (10) on pump (4).
- b. Position pump and motor (5) on foundation with mounting screw holes aligned.
- c. Secure motor to foundation with four hexhead capscrews (6), washers (7), lockwashers (8) and plain hex nuts (9).
- d. Connect suction piping at union (11) to inlet side of pump.
- e. Connect discharge piping at union (2) located on top of pump.
- f. Replace or install new insulating material on unions at inlet and outlet sides of pump.
- g. Open pump suction (12) and discharge (1) valves.
- h. Remove tags and connect electrical leads at junction box on motor.
- i. Run pump and check for proper operation and leaks.

---

2-96. Replace Alternating Current Motor (Fresh Water Centrifugal Unit).

---

This task covers: a. Removal, b. Replacement.

---

### **INITIAL SETUP**

#### **Tools**

Tool kit, general mechanic's,  
5180-00-699-5273

#### **Materials/Parts**

Alternating current motor  
P/N 23255F  
Warning tags, Item 1, Appendix C

#### **Equipment Condition**

Electrical power to pump unit turned  
OFF at ship service switchboard and  
tagged "Out of Service - Do Not  
Operate."  
Closed valves tagged "'Out of Service -  
Do Not Operate."

### **REMOVAL**

- a. Refer to paragraph 2-95 to remove centrifugal pump unit.
- b. Refer to paragraph 3-109 to disassemble centrifugal pump from alternating current motor.

### **REPLACEMENT**

- a. Refer to paragraph 3-109 for assembly of centrifugal pump on alternating current motor.
- b. Refer to paragraph 2-95 to replace centrifugal pump unit.

---

2-97. Replace/Repair Centrifugal Pump Unit (Fresh Water Booster). (FIGURE 2-82)

---

This task covers: a. Removal, b. Repair, c. Replacement.

---

INITIAL SETUP

Tools

Tool kit, general mechanic's,  
5180-00-699-5273  
Tool kit, electrician's,  
5180-00-391-1087

Equipment Condition

Electrical power to pump unit turned  
OFF at auxiliary machinery motor  
control center and tagged "Out of  
Service - Do Not Operate."  
Closed valves tagged "Out of  
Service - Do Not Operate."

Materials/Parts

Centrifugal pump unit  
P/N SMP 1000  
Motor A/C P/N 0743  
Warning tags, Item 1, Appendix C

---

REMOVAL

- a. Tag and disconnect electrical leads at junction box (1) on motor.
- b. Close pump suction (11) and discharge (4) valves.
- c. Disconnect discharge piping at union (5) located on top of pump (3).
- d. Disconnect suction piping at union (10) on front end of pump.
- e. Remove four hexhead capscrews (12, 14) securing motor (2) to motor foot (13).
- f. Remove pump (3) and motor (2).
- g. Position pipe wrench on adapter with counterclockwise rotation to remove adapter (8) and attached fitting from pump casing.
- h. Position pipe wrench on nipple (6) with counterclockwise rotation to remove nipple and attached fittings from top of pump.

REPAIR

Repair of centrifugal pump unit consists of replacing pump (3), and motor (2).

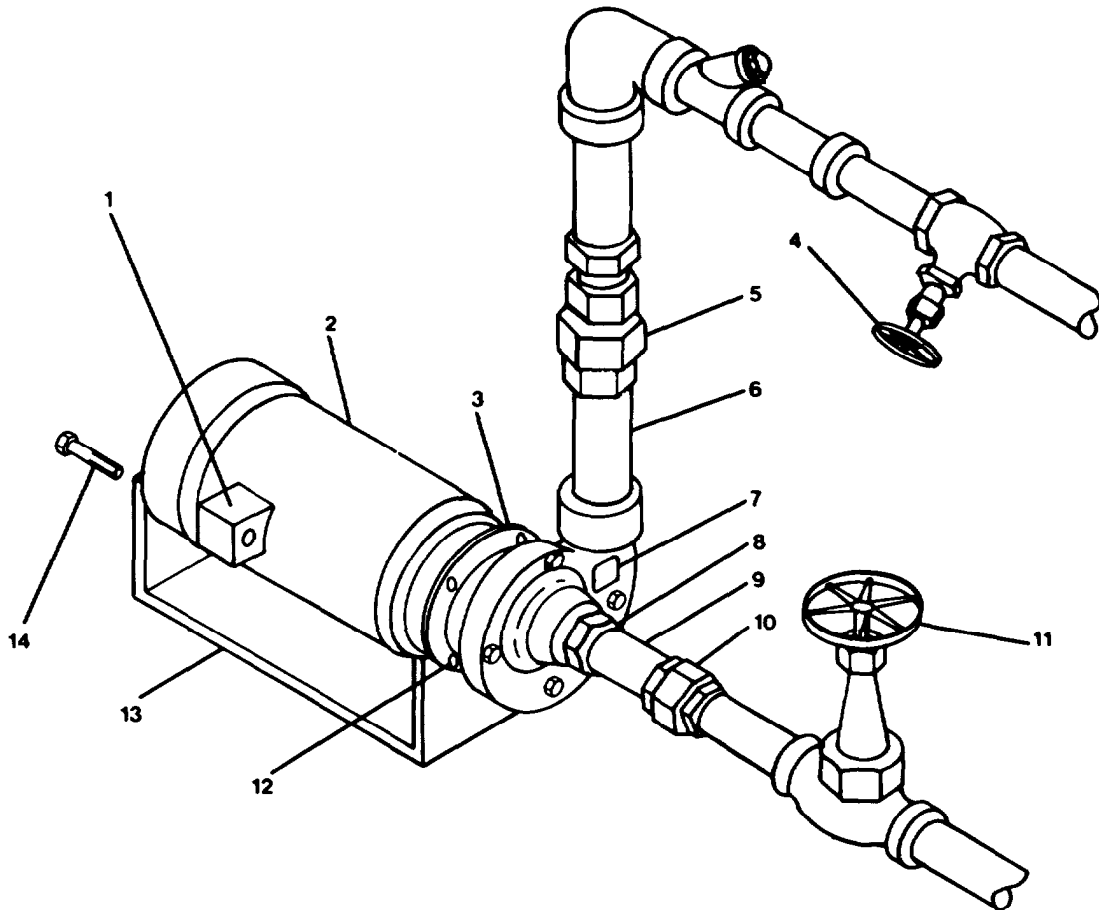


FIGURE 2-82. Pump Assembly (Fresh Water Booster).

REPLACEMENT

- a. Install nipple (6) with attached fittings at top of pump (3).
- b. Install adapter (8) with attached fittings on pump casing.
- c. Position pump and motor on motor foot (13) with mounting screw holes aligned.

- d. Secure motor (2) to motor foot with four hexhead capscrews (12, 14).
- e. Connect suction piping at union (10) on front end of pump.
- f. Connect discharge piping at union (5) located on top of pump.
- g. Open pump suction (11) and discharge (4) valves.
- h. Remove tag and connect electrical leads at junction box (1) on motor.
- i. Restore power to pump assembly.
- j. Run pump to test rotation direction and check for leaks.



---

**2-98. Replace Alternating Current Motor (Fresh Water Booster Centrifugal Pump unit) .**

---

This task covers: a. Removal, b. Replacement.

---

**INITIAL SETUP****Tools**

Tool Kit, General Mechanic's,  
5180-00-699-5273

**General Safety Instruction**

Electrical power to pump unit turned  
OFF at auxiliary machinery motor  
control center and tagged "Out of  
Service - Do Not Operate."

**Materials/Parts**

Alternating current motor P/N 0743  
Warning Tag, Item 1, Appendix C

Closed valves tagged "Out of Service -  
Do Not Operate."

---

**REMOVAL**

- a. Refer to paragraph 2-97 to remove centrifugal pump unit.
- b. Refer to paragraph 3-110 to disassemble centrifugal pump from alternating current motor.

**REPLACEMENT**

- a. Refer to paragraph 3-110 for assembly of centrifugal pump on alternating current motor.
- b. Refer to paragraph 2-97 to replace centrifugal pump unit.

---

**2-99. Replace/Repair Centrifugal Pump Unit (Auxiliary Seawater Cooling). (FIGURE 2-83)**

---

This task covers:      a. Removal,      b. Repair,      c. Replacement.

---

**INITIAL SETUP**

Tools

Tool Kit, General Mechanic's,  
5180-00-699-5273

General Safety Instruction

Electrical power to pump unit turned  
OFF at auxiliary machinery motor  
control center and tagged "Out of  
Service - Do Not Operate."

Materials/Parts

Centrifugal Pump Unit, P/N ABZCH2-532-250  
Warning Tag, Item 1, Appendix C

Closed valves tagged "Out of Service -  
Do Not Operate."

---

**REMOVAL**

- a. Tag and disconnect electrical leads at junction box (16) on motor.
- b. Remove insulating shroud from discharge piping on outlet side of pump. Retain insulating shroud for assembly.
- c. Remove four hex plain nuts (5), lockwashers (4), washers (3) and hexhead capscrews (2) securing piping flange (6) to pump flange (7).
- d. Separate flanges (6, 7) and remove gasket (17).
- e. Remove four hexhead capscrews (9) and lockwashers (10) securing piping flange (8) to pump unit (1).

**NOTE**

**Four soldiers are required for motor and pump removal.**

- f. Remove four hex plain nuts (12), lockwashers (13), washers (14) and hexhead capscrews (15) pump unit (1) to foundation.

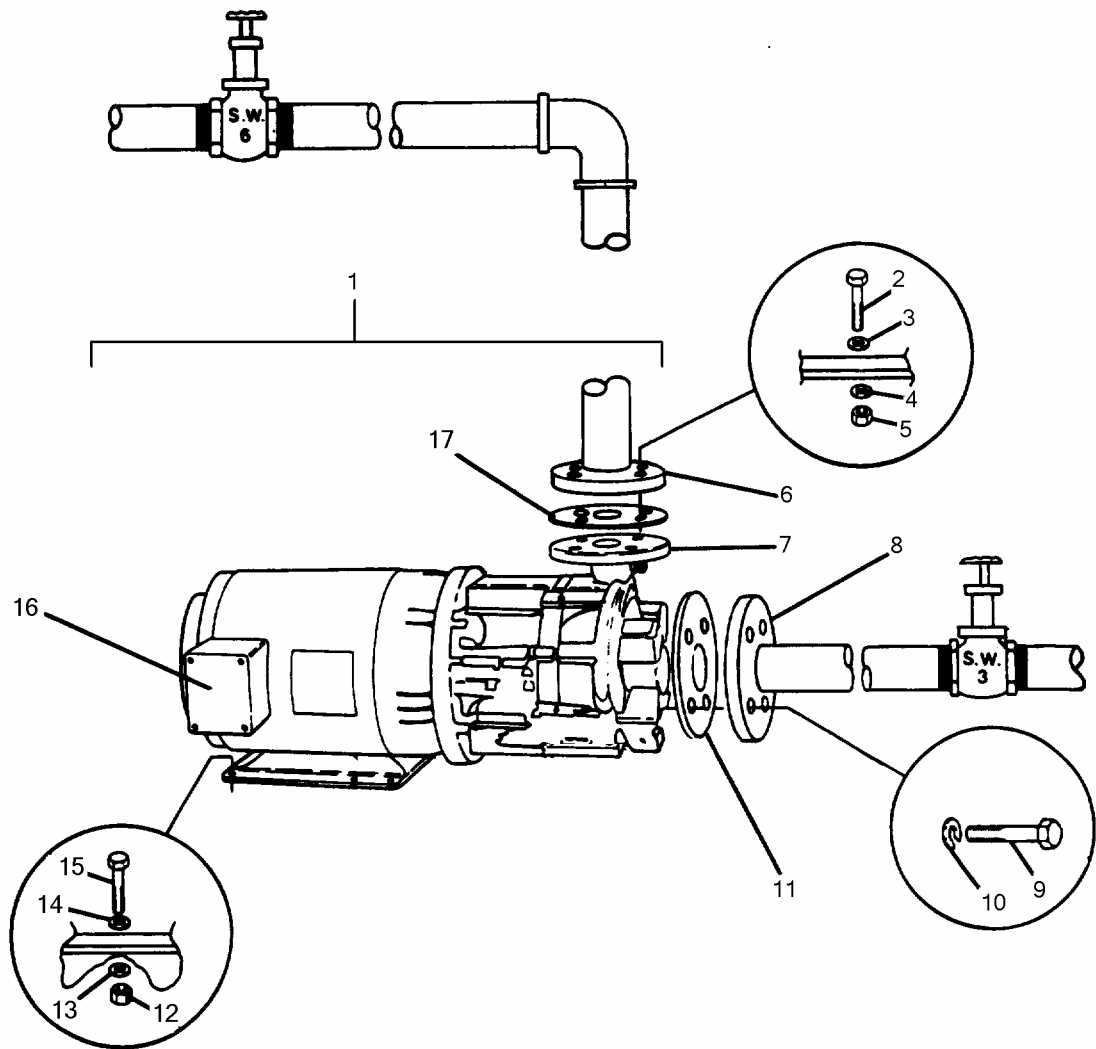


FIGURE 2-83. Centrifugal Pump Unit (Auxiliary Seawater Cooling).

- g. Separate motor and pump from piping flange (8).
- h. Remove gasket (11).
- i. Remove pump unit (1).

### REPAIR

Repair of centrifugal pump unit consists of replacing: centrifugal pump unit (1).

### REPLACEMENT

#### NOTE

**Four soldiers are required for motor and pump installation.**

- a. Position motor and pump on foundation.
- b. Install gasket (11) between pump and piping flange (8).
- c. Slide motor and pump towards flange (8) with mounting screw holes aligned with flange, motor and pump.
- d. Secure pump unit (1) to foundation with four hexhead capscrews (15), washers (14), lockwashers (13) and hex plain nuts (12).
- e. Separate flanges (6 and 7) to install gasket (17).
- f. Secure piping flange (6) to pump flange (7) with four hexhead capscrews (2), washers (3), lockwashers (4) and hex plain nuts (5).
- g. Install insulating shroud over discharge piping on outlet side of pump.
- h. Remove "Out of Service" tags and open pump suction (S.W.-3) and discharge (S.W.-6).
- i. Remove tags and connect electrical leads at junction box (16) on motor.
- j. Remove tags and restore power to pump unit.
- k. Run pump to test for correct rotation and leaks.

---

## 2-100. Replace Electric Motor (Auxiliary Seawater Centrifugal Pump Unit).

---

This task covers: a. Removal, b. Replacement.

---

### INITIAL SETUP

#### Tools

Tool kit, general mechanic's,  
5180-00-699-5273

#### Materials/Parts

Electric motor  
P/N O-242-0  
Warning tags, Item 1, Appendix C

#### Equipment Condition

Electrical power to pump unit turned OFF at auxiliary machinery motor control center and tagged "Out of Service - Do Not Operate." Valves S.W.-3 and S.W.-6 closed and tagged "Out of Service - Do Not Operate."

---

### REMOVAL

- a. Refer to paragraph 2-99 to remove centrifugal pump unit.
- b. Refer to paragraph 3-111 to disassemble centrifugal pump from electric motor.

### REPLACEMENT

- a. Refer to paragraph 3-111 for assembly of centrifugal pump on electric motor.
- b. Refer to paragraph 2-99 to replace centrifugal pump unit.

---

**2-101. Replace/Repair Rotary Pump Unit (Fuel Oil Transfer). (FIGURE 2-84)**

---

This task covers: a. Removal, b. Repair, c. Replacement.

---

**INITIAL SETUP**

**Tools**

Tool kit, general mechanic's,  
5180-00-699-5273  
Tool kit, electrician's,  
5180-00-391-1087

**Equipment Condition**

Electrical power to pump unit  
turned OFF and tagged "Out of Service  
Do Not Operate."  
Valves closed and tagged "Out of  
Service - Do Not Operate."

**Materials/Parts**

Rotary pump unit P/N 20R007001  
AC motor P/N S54  
Warning tags, Item 1, Appendix C

---

**REMOVAL**

**NOTE**

This procedure may also be used for the  
prelubricating oil transfer pump and dirty  
lubricating oil pump since all three pumps  
are the same.

- a. Tag and disconnect electrical leads at the junction box (15) on motor (16).
- b. Close pump suction (1) and discharge (19) valves.
- c. Disconnect discharge piping at union (20) on outlet side of pump.
- d. Disconnect suction piping at union (2) on inlet side of pump.
- e. Remove eight hex plain nuts (11), lockwashers (12), washers (13) and hexhead capscrews (14) securing motor (16) on baseplate (17).
- f. Remove two hex plain nuts (6), lockwashers (7) and hexhead capscrews (8) securing coupling guard (9) on baseplate. Remove coupling guard.
- g. Remove four hex plain nuts (3), lockwashers (4) and hexhead capscrews (5) securing pump shaft bracket (18) on baseplate.
- h. Separate pump assembly (21) from motor (16) at coupling (10).

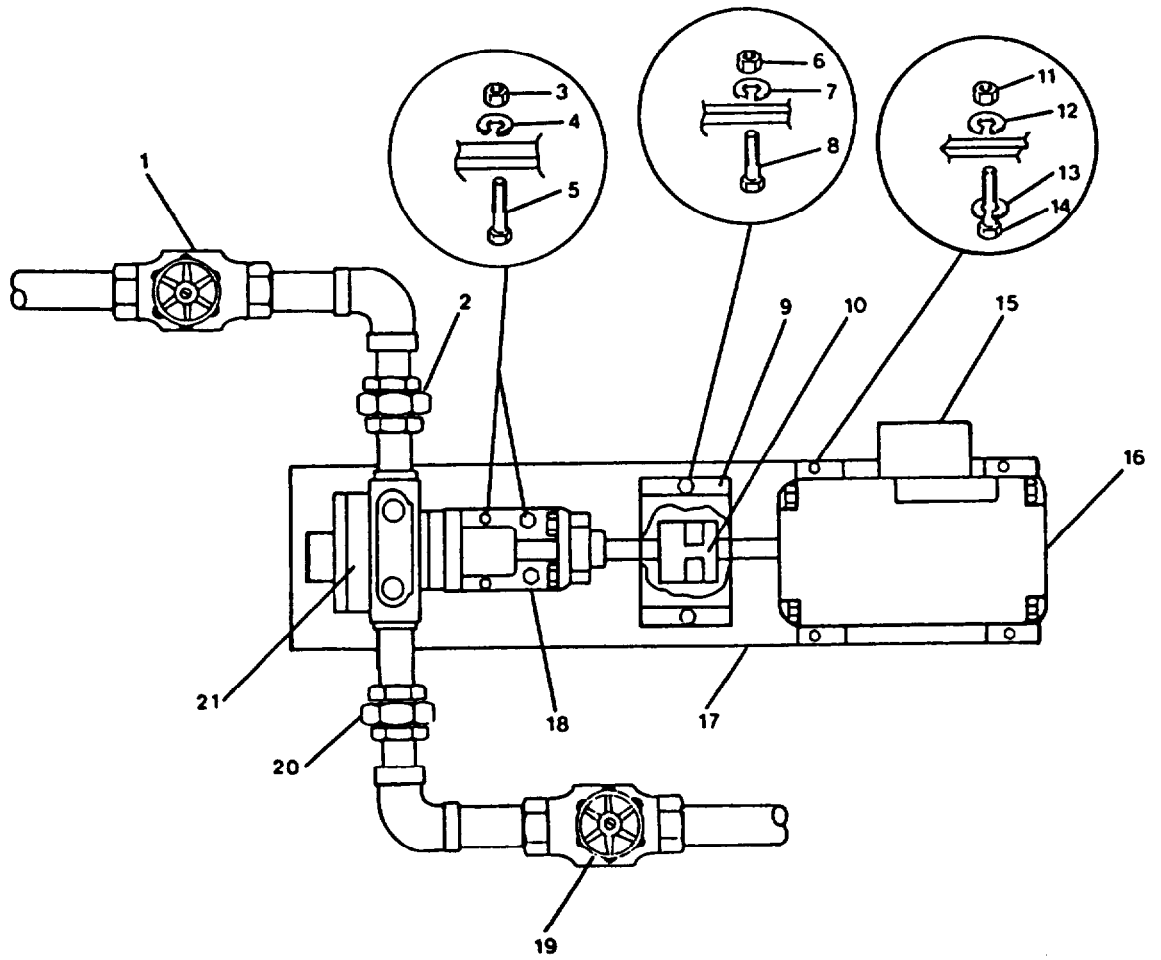


FIGURE 2-84. Rotary Pump Unit (Fuel Oil Transfer). Repair.

## **TM 55-1905-223-24-18-1**

- i. Remove pump assembly.
- j. Remove motor.

### **REPAIR**

Repair of rotary pump unit consists of replacing rotary pump (21) and motor (16).

### **REPLACEMENT**

- a. Position motor (16) on baseplate (17) with mounting screw holes aligned.
- b. Position pump shaft bracket (18) and pump assembly (21) on baseplate.
- c. Connect pump assembly to motor at coupling (10).
- d. Secure pump shaft bracket (18) to baseplate (17) with four hexhead capscrews (5), lockwashers (4) and plain hex nuts (3).
- e. Position coupling guard (9) over coupling (10) and aligned with mounting screw holes on baseplate.
- f. Secure coupling guard with two hexhead capscrews (8), lockwashers (7) and plain hex nuts (6).
- g. Secure motor with four hexhead capscrews (14), washers (13), lockwashers and plain hex nuts (11).
- h. Connect suction piping at union (2) on inlet side of pump.
- i. Connect discharge piping at union (20) on outlet side of pump.
- j. Open suction (1) and discharge (19) valves.
- k. Remove tags and connect leads to junction box (15) on motor.
- l. Remove tags and restore power to pump unit.
- m. Run pump to test for correct direction of rotation and leaks.



---

## 2-102. Replace Rotary Pump (Fuel Oil Transfer). ( FIGURE 2-85)

---

This task covers: a. Removal, b. Replacement.

---

### INITIAL SETUP

#### **Tools**

Tool kit, general mechanic's,  
5180-00-699-5273  
Tool kit, electrician's,  
5180-00-391-1087

#### **Equipment Condition**

Electrical power to pump unit  
turned OFF and tagged "Out of Service  
Do Not Operate."  
Valves Closed and tagged "Out of  
Service - Do Not Operate."

#### **Materials/Parts**

Rotary pump unit P/N 20DR  
Warning tags, Item 1, Appendix C

---

### REMOVAL

#### **NOTE**

This procedure may also be used for the  
prelubricating oil transfer pump and dirty  
lubricating oil pump since all three pumps  
are the same.

- a. Close pump suction (1) and discharge (14) valves.
- b. Disconnect discharge piping at union (15) on outlet side of pump.
- c. Disconnect suction piping at union (2) on inlet side of pump.
- d. Remove two hex plain nuts (6), lockwashers (7) and hexhead capscrews (8) securing coupling guard (9) on baseplate (12). Remove coupling guard.
- e. Remove four hex plain nuts (3), lockwashers (4) and hexhead capscrews (5) securing pump shaft bracket (13) on baseplate.
- f. Separate pump assembly (16) from motor (11) at coupling (10).
- g. Remove pump assembly.

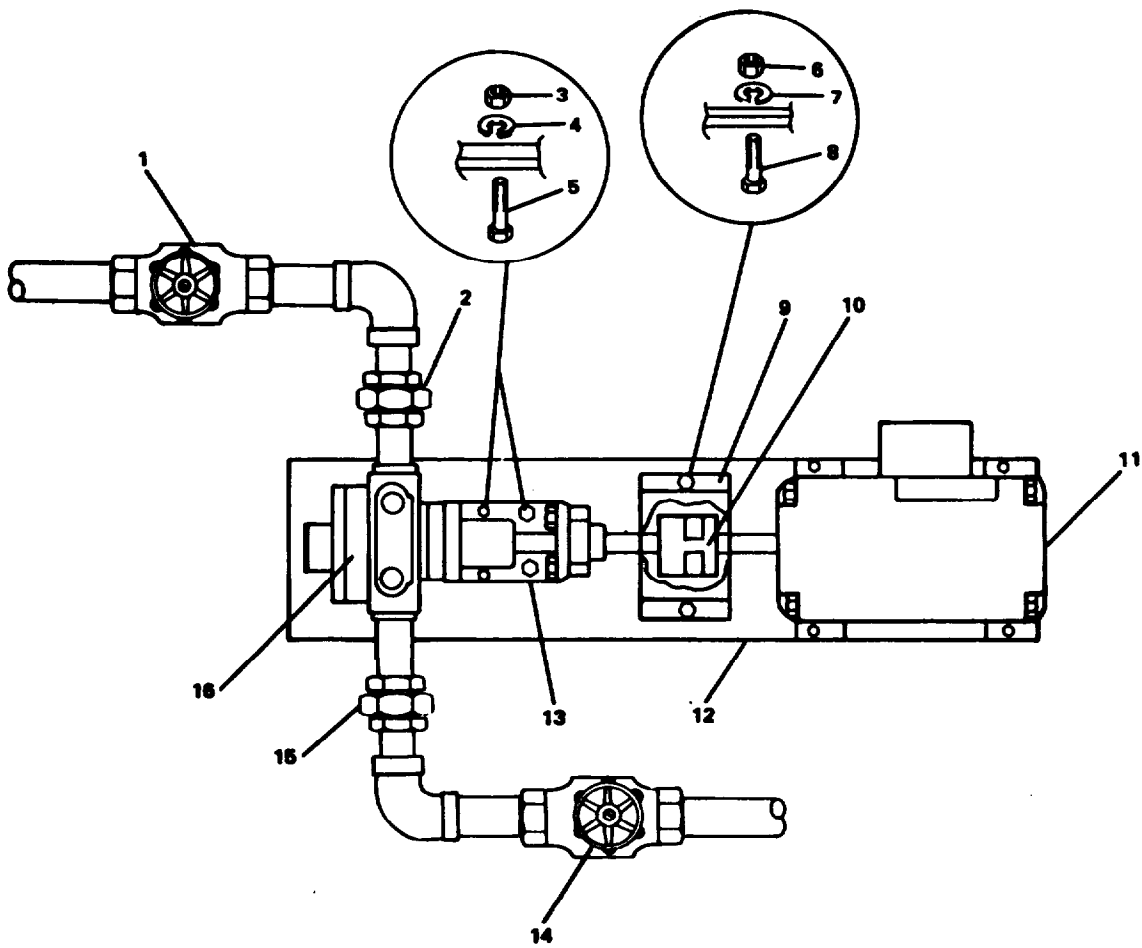


FIGURE 2-85. Rotary Pump Unit (Fuel Oil Transfer). Replace.

**REPLACEMENT**

- a. Position pump shaft bracket (13) and pump assembly (16) on baseplate (12).
- b. Connect pump assembly to motor at coupling (10).
- c. Secure pump shaft bracket (13) to baseplate (12) with four hexhead capscrews (5), lockwashers (4) and plain hex nuts (3).
- d. Position coupling guard (9) over coupling (10) and aligned with mounting screw holes on baseplate.
- e. Secure coupling guard with two hexhead capscrews (8), lockwashers (7) and plain hex nuts (6).
- f. Connect suction piping at union (2) on inlet side of pump.
- g. Connect discharge piping at union (15) on outlet side of pump.
- h. Open suction (1) and discharge (14) valves.
- i. Remove tags and restore power to pump unit.
- j. Run to test.

**2-103. Replace Alternating Current Rotor (Fuel Oil Transfer Rotary Pump Unit).**

---

This task covers: a. Removal, b. Replacement.

---

**INITIAL SETUP**

**Tools**

Tool kit, general mechanic's,  
5180-00-699-5273

**Materials/Parts**

Alternating current motor  
P/N 554  
Warning tags, Item 1, Appendix C

---

**Equipment Condition**

Electrical power to pump unit turned  
OFF and tagged "Out of Service - Do  
Not Operate."  
Appropriate valves closed and tagged.

**REMOVAL/REPLACEMENT**

Refer to paragraph 2-101 for removal/replacement of alternating current motor.

---

**2-104. Replace/Repair Rotary Pump Unit (Prelubricate Oil Transfer).  
(FIGURE 2-86)**

---

This task covers: a. Removal, b. Repair, c. Replacement.

---

**INITIAL SETUP****Tools**

Tool kit, general mechanic's,  
5180-00-699-5273  
Tool kit, electrician's,  
5180-00-391-1087

**Equipment Condition**

Electrical power to pump unit turned  
OFF and tagged "Out of Service - Do  
Not Operate."  
Appropriate valves closed and tagged  
"Out of Service - Do Not Operate."

**Materials/Parts**

Pump rotary unit P/N 30R035001  
Alternating current  
motor P/N JEV  
Warning tags, Item 1, Appendix C

---

**REMOVAL**

- a. Tag and disconnect electrical leads at junction box (15) on motor.
- b. Close pump suction (1) and discharge (21) valves.
- c. Close pump relief valve (19).
- d. Disconnect discharge piping at union (22) on outlet side of pump.
- e. Disconnect pump relief piping at union (20).
- f. Position pipe wrench on elbow (25) for counterclockwise rotation to remove nipple (24) with valve (19) from pump.
- g. Remove four plain hex nuts (11), lockwashers (12), washers (13) and hexhead capscrews (14) securing motor (16) to baseplate (17).
- h. Remove two plain hex nuts (6), lockwashers (7) and hexhead capscrews (8) securing coupling guard (9) to baseplate. Remove coupling guard.
- i. Remove four plain hex nuts (3), lockwashers (4) and hexhead capscrews (5) securing shaft bracket (18) to baseplate.
- j. Separate pump assembly (26) from motor (16) at coupling (10).

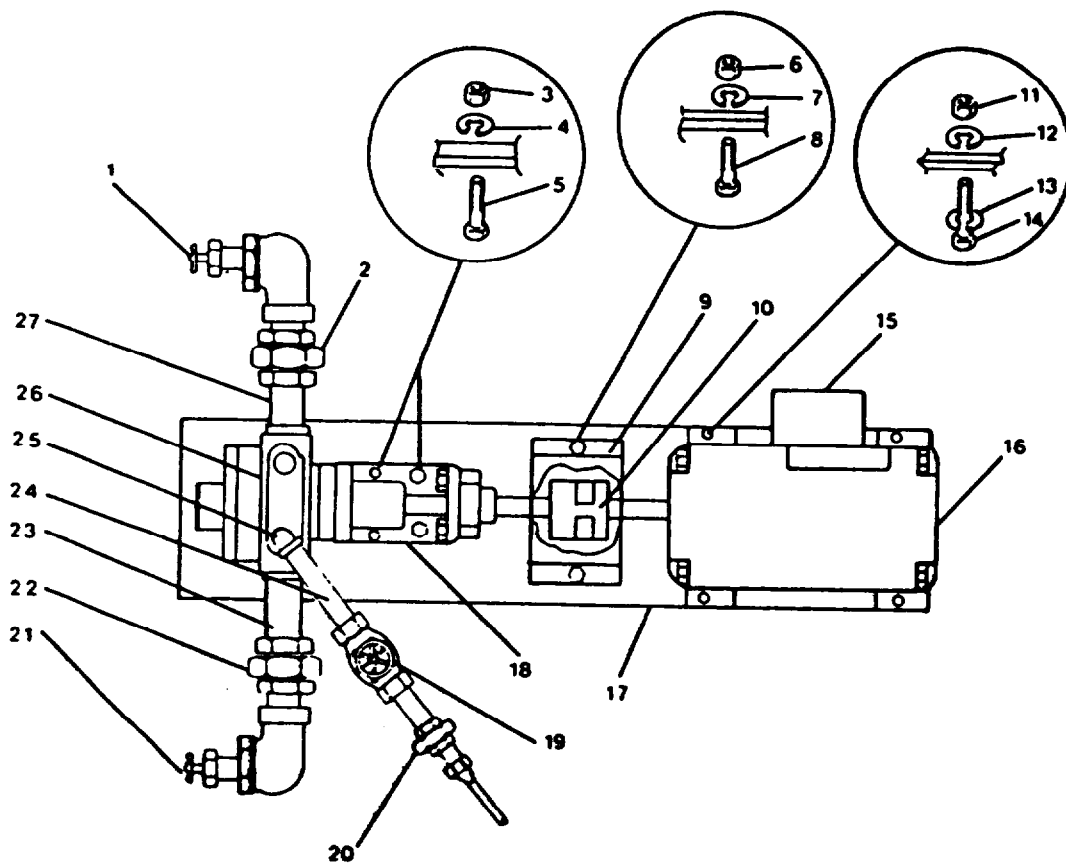


FIGURE 2-86. Rotary Pump Unit (Prelube Oil Transfer).

- k. Remove pump assembly.
- l. Disconnect pipe nipples (23) and (27) from pump.
- m. Remove motor.

### **REPAIR**

Repair of rotary pump unit consists of replacing rotary pump (26) and motor (16).

### **REPLACEMENT**

- a. Position motor (16) on baseplate (17) with mounting screw holes aligned.
- b. Install pipe nipples (23) and (27) on pump.
- c. Position pump assembly (26) on baseplate.
- d. Connect pump assembly with motor (16) at coupling (10).
- e. Secure shaft bracket (18) to baseplate with four hexhead capscrews (5), lockwashers (4) and plain hex nuts (3).
- f. Position coupling guard (9) over mounting screw holes on baseplate.
- g. Secure coupling guard with two hexhead capscrews (8), lockwashers (7) and plain hex nuts (6).
- h. Secure motor with four hexhead capscrews (14), washers (13), lockwashers (12) and hex plain nuts (11),
- i. Install pump relief piping elbow (25) with nipple (24) and valve (19) on pump.
- j. Connect pump relief piping at union (20).
- k. Connect suction piping at union (2) on inlet side of pump.
- l. Connect discharge piping at union (22) on outlet side of pump.
- m. Open pump relief valve (19).
- n. Open suction (1) and discharge (21) valves.
- o. Remove tags and connect electrical leads to junction box (15) on motor.
- p. Remove tag and restore power to pump unit.
- q. Run to test.

---

**2-105. Replace/Repair Rotary Pump (Prelubricate Oil Transfer).  
(FIGURE 2-87)**

---

This task covers: a. Removal, b. Repair, c. Replacement.

---

**INITIAL SETUP**

**Tools**

Tool kit, general mechanic's,  
5180-00-699-5273  
Tool kit, electrician's,  
5180-00-391-1087

**Equipment Condition**

Electrical power to pump unit turned  
OFF and tagged "Out of Service - Do  
Not Operate."  
Appropriate valves closed and tagged  
"Out of Service - Do Not Operate."

**Materials/Parts**

Pump rotary unit P/N 30DR  
Warning tags, Item 1, Appendix C

---

**REMOVAL**

- a. Close pump suction (1) and discharge (16) valves.
- b. Close pump relief valve (14).
- c. Disconnect discharge piping at union (17) on outlet side of pump.
- d. Disconnect pump relief piping at union (15).
- e. Position pipe wrench on elbow (20) for counterclockwise rotation to remove nipple (19) with valve (14) from pump.
- f. Remove two plain hex nuts (6), lockwashers (7) and hexhead capscrews (8) securing coupling guard (9) to baseplate (12). Remove coupling guard.
- g. Remove four plain hex nuts (3), lockwashers (4) and hexhead capscrews (5) securing shaft bracket (13) to baseplate.
- h. Separate pump assembly (21) from motor (11) at coupling (10).
- i. Remove pump assembly.
- j. Disconnect pipe nipples (18) and (22) from pump.



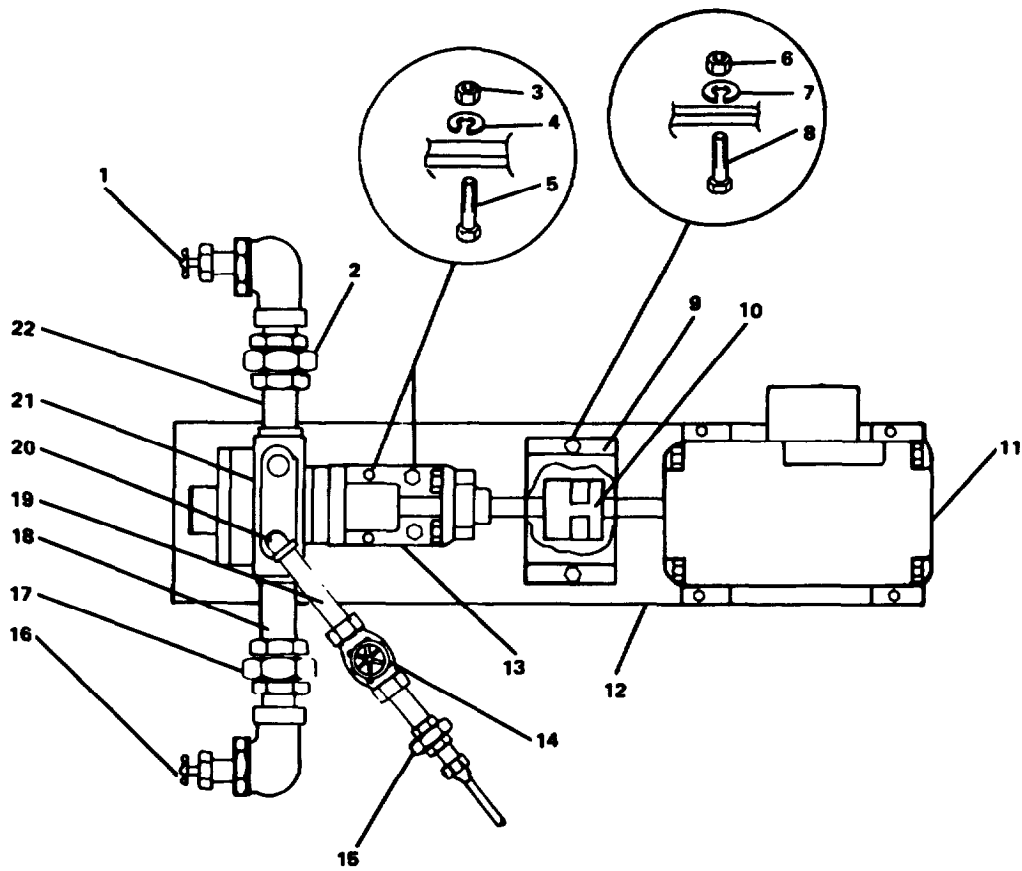


FIGURE 2-87. Rotary Pump (Pre-lube Oil Transfer).

**REPAIR**

Repair of rotary pump consists of replacing rotary pump (26).

**REPLACEMENT**

- a. Install pipe nipples (18) and (22) on pump (21).
- b. Position pump assembly (21) on baseplate (12).
- c. Connect pump assembly with motor (11) at coupling (10).
- d. Secure shaft bracket (13) to baseplate with four hexhead capscrews (5), lockwashers (4) and plain hex nuts (3).
- e. Position coupling guard (9) over mounting screw holes on baseplate.
- f. Secure coupling guard with two hexhead capscrews (8), lockwashers (7) and plain hex nuts (6).
- g. Install pump relief piping elbow (20) with nipple (19) and valve (14) on pump.
- h. Connect pump relief piping at union (15).
- i. Connect suction piping at union (2) on inlet side of pump.
- j. Connect discharge piping at union (17) on outlet side of pump.
- k. Open pump relief valve (14).
- l. Open suction (1) and discharge (16) valves.
- m. Remove tag and restore power to pump unit.
- n. Run to test.

---

**2-106. Replace Alternating Current Motor (Prelube Oil Transfer Rotary Pump unit.**

---

This task covers: a. Removal, b. Replacement.

---

**INITIAL SETUP**

**Tools**

Tool kit, general mechanic's,  
5180-00-699-5273

**Materials/Parts**

Alternating current motor  
P/N JEV  
Warning tags, Item 1, Appendix C

**Equipment Condition**

Electrical power to pump unit turned  
OFT and tagged "Out of Service - Do  
Not Operate."  
Appropriate valves closed tagged  
"Out of Service - Do Not Operate."

---

**REMOVAL/REPLACEMENT**

Refer to paragraph 2-104 for removal/replacement of alternating current motor.

---

**2-107. Replace/Repair Rotary Pump Unit (Dirty Lubricate Oil). (FIGURE 2-88)**

---

This task covers: a. Removal, b. Repair, c. Replacement.

---

**INITIAL SETUP**

**Tools**

Tool kit, general mechanic's,  
5180-00-699-5273  
Tool kit, electrician's,  
5180-00-391-1087

**Equipment Condition**

Electrical power to pump unit turned  
OFF and tagged "Out of Service - Do  
Not Operate."  
Appropriate valved closed and tagged  
"Out of Service - Do Not Operate."

**Materials/Parts**

Rotary pump unit  
P/N 20R007003  
Alternating current motor  
P/N S55  
Warning tags, Item 1, Appendix C

---

**REMOVAL**

- a. Tag and disconnect electrical leads at junction box on motor (12).
- b. Close pump suction (3) and discharge (18) valves.
- c. Close pump relief valve (1).
- d. Disconnect discharge piping at union (17) on outlet side of pump.
- e. Disconnect suction piping at union (4) on inlet side of pump.
- f. Disconnect pump relief piping at connector (2).
- g. Position pipe wrench on elbow (20) for counterclockwise rotation to remove-nipple (22) and valve (1) section from pump.
- h. Remove four plain hex nuts (7) lockwashers (8), and hexhead capscrews (9) securing motor (10) to baseplate (13).
- i. Remove two plain hex nuts (7), lockwashers (8) and hexhead capscrews (9) securing coupling guard (10) to baseplate. Remove coupling guard.
- j. Remove four plain hex nuts (14), lockwashers (15) and hexhead capscrews (16) securing shaft bracket (6) to baseplate.

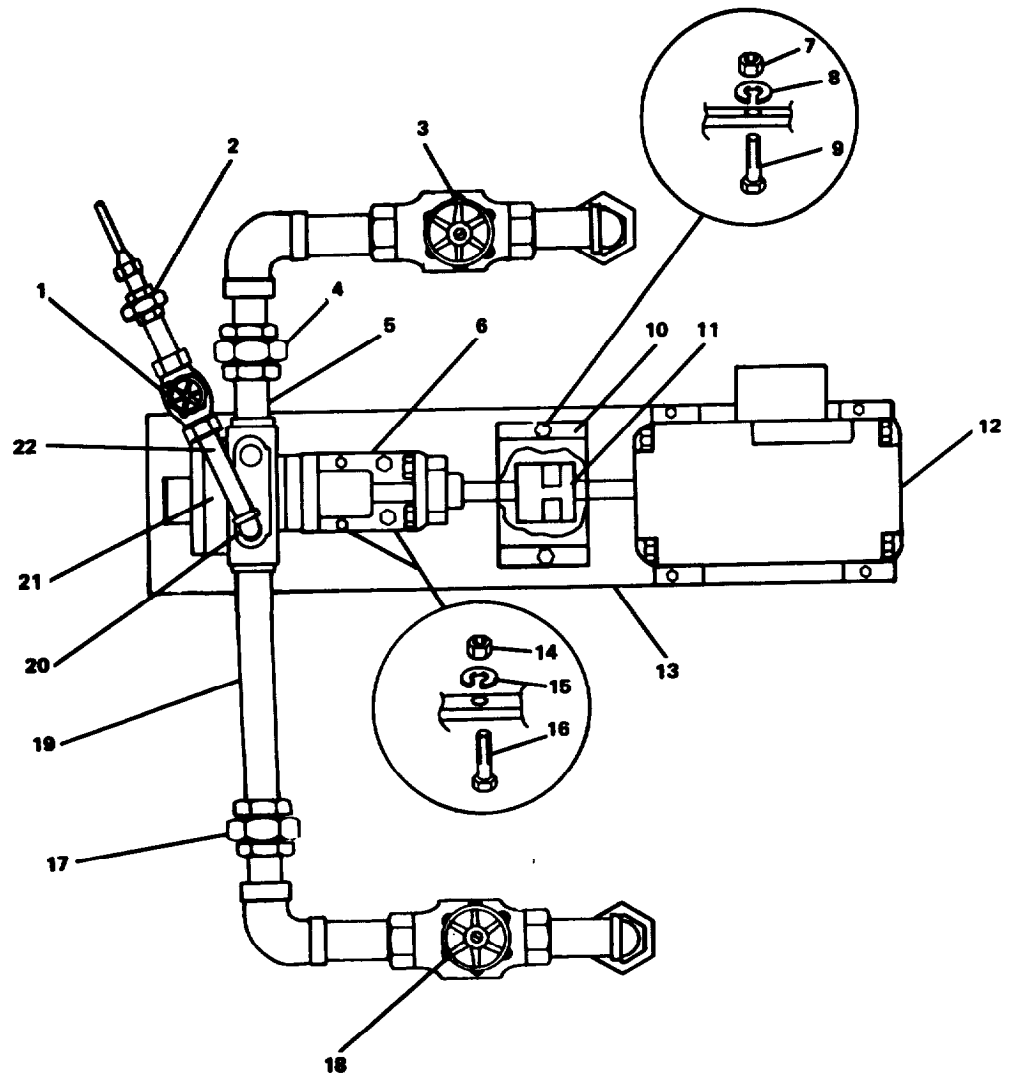


FIGURE 2-88. Rotary Pump Unit (Dirty Lubricate Oil).

**NOTE**

Four soldiers will be required for pump assembly and piping removal.

- k. Separate pump assembly (21) from motor at coupling (11).
- l. Lift pump assembly and piping from baseplate and position pump assembly and piping in an area with adequate space to disconnect piping from pump.

**CAUTION**

To prevent distortion or warping, be sure to protect pump shaft from stress or strain when piping is disconnected from pump.

- m. Position pipe wrench on nipple (19) for counterclockwise rotation to remove discharge piping assembly from outlet side of pump.
- n. Position pipe wrench on nipple (5) for counterclockwise rotation to remove suction piping assembly from inlet side of pump.
- o. Remove motor (17).

**REPAIR**

Repair of rotary pump unit consists of replacing motor (12) and rotary pump (21).

**REPLACEMENT**

- a. Position motor (12) on baseplate (13) with mounting screw holes aligned.

**NOTE**

Four soldiers will be required for pump assembly and piping installation.

**CAUTION**

To prevent distortion or warping, be sure to protect pump shaft from stress or strain when piping are connected to pump.

- b. Position pump assembly (21) in an area with adequate space to connect piping to pump.
- c. Install suction piping assembly at nipple (5) into inlet side of pump.
- d. Position pipe wrench on nipple for clockwise rotation to secure piping to pump.

- e. Install discharge piping assembly at nipple (19) into outlet side of pump.
- f. Position pipe wrench on nipple for clockwise rotation to secure piping to pump.
- g. Position pump assembly and piping on baseplate (13).
- h. Connect pump assembly (21) to motor (12) at coupling (11).
- i. Position shaft bracket (6) over mounting screw holes in baseplate.
- j. Secure shaft bracket with four hexhead capscrews (16), lockwashers (15) and hex plain nuts (14).
- k. Position coupling guard (10) on baseplate with mounting screw aligned.
- l. Secure coupling guard with two hexhead capscrews (9), lockwashers (8) and hex plain nuts (7).
- m. Secure motor (12) with four hexhead capscrews, lockwashers and hex plain nuts.
- n. Install pump relief elbow (20) on pump. Position pipe wrench on elbow for clockwise rotation to secure nipple (22) and valve (1) section pump.
- o. Connect pump relief piping at connector (2).
- p. Connect suction piping at union (4) on inlet side of pump.
- q. Connect discharge piping at union (17) on outlet side of pump.
- r. Open pump relief valve (1).
- s. Open pump suction (3) and discharge (18) valves.
- t. Remove tags and connect electrical leads at junction box on motor (12).
- u. Run to test.

**2-108. Replace/Repair Rotary Pump (Dirty Lubricate Oil). (FIGURE 2-89)**

---

This task covers: a. Removal, b. Repair, c. Replacement.

---

**INITIAL SETUP**

**Tools**

Tool kit, general mechanic's,  
5180-00-699-5273  
Tool kit, electrician's,  
5180-00-391-1087

**Equipment Condition**

Electrical power to pump unit turned  
OFF and tagged "Out of Service - Do  
Not Operate."  
Appropriate valves closed and tagged  
"Out of Service - Do Not Operate."

**Materials/Parts**

Rotary pump unit  
P/N 20DR  
Warning tags, Item 1, Appendix C

---

**REMOVAL**

- a. Close pump suction (3) and discharge (18) valves.
- b. Close pump relief valve (1).
- c. Disconnect discharge piping at union (17) on outlet side of pump.
- d. Disconnect suction piping at union (4) on inlet side of pump.
- e. Disconnect pump relief piping at connector (2).
- f. Position pipe wrench on elbow (20) for counterclockwise rotation to remove nipple (22) and valve (1) section from pump.
- g. Remove two plain hex nuts (7), lockwashers (8) and hexhead capscrews (9) securing coupling guard (10) to baseplate (13). Remove coupling guard.
- h. Remove four plain hex nuts (14), lockwashers (15) and hexhead capscrews (16) securing shaft bracket (6) to baseplate.



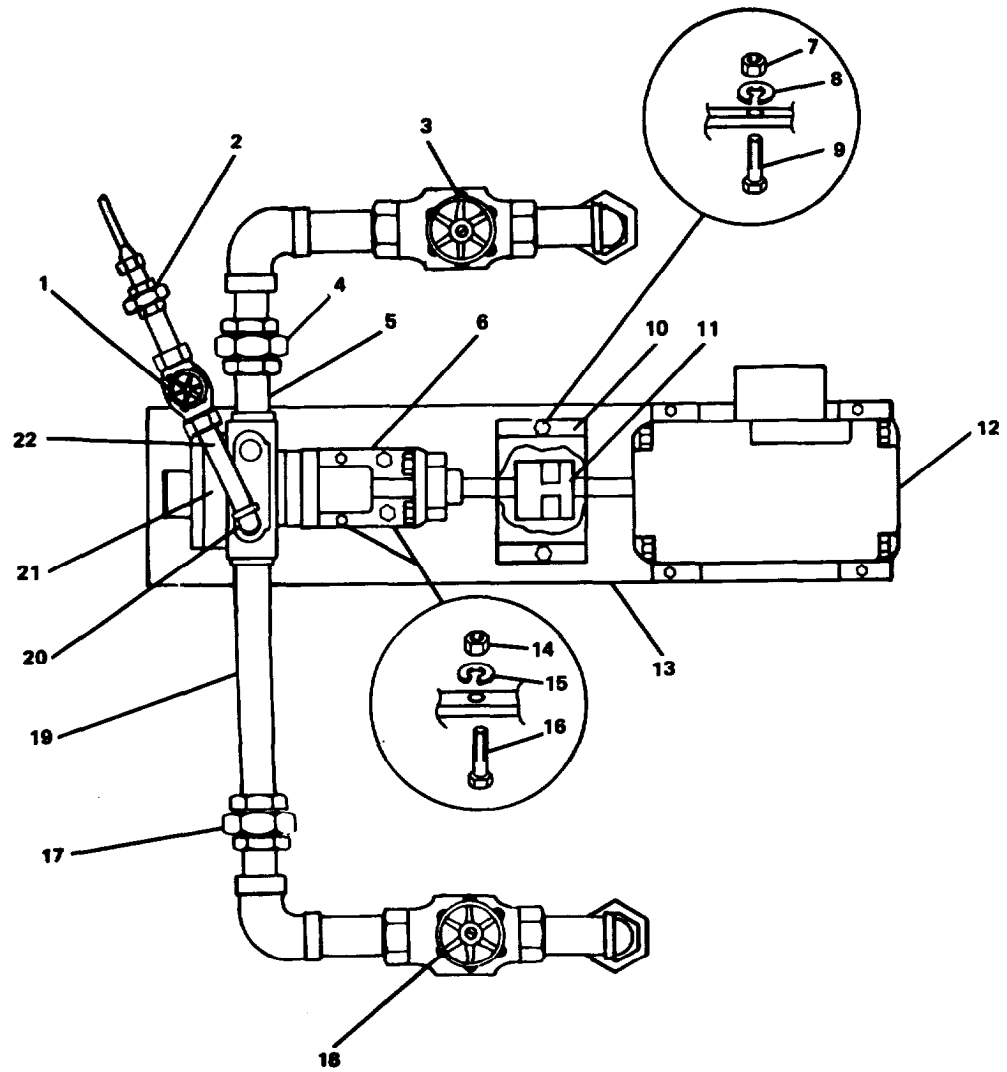


FIGURE 2-89. Rotary Pump (Dirty Lubricate Oil)

**NOTE**

Four soldiers will be required for pump assembly and piping removal.

- i. Separate pump assembly (21) from motor (12) at coupling (11).
- j. Lift pump assembly and piping from baseplate and position pump assembly and piping in an area with adequate space to disconnect piping from pump.

**CAUTION**

To prevent distortion or warping, be sure to protect pump shaft from stress or strain when piping is disconnected from pump.

- k. Position pipe wrench on nipple (19) for counterclockwise rotation to remove discharge piping assembly from outlet side of pump.
- l. Position pipe wrench on nipple (5) for counterclockwise rotation to remove suction piping assembly from inlet side of pump.

**REPAIR**

Repair of rotary pump unit consists of replacing rotary pump (21).

**REPLACEMENT**

**NOTE**

Four soldiers will be required for pump assembly and piping installation.

**CAUTION**

To prevent distortion or warping, be sure to protect pump shaft from stress or strain when piping is connected to pump.

- a. Position pump assembly (21) in an area with adequate space to connect piping to pump.
- b. Install suction piping assembly at nipple (5) into inlet side of pump.
- c. Position pipe wrench on nipple for clockwise rotation to secure piping to pump.

- d. Install discharge piping assembly at nipple (19) into outlet side of pump.
- e. Position pipe wrench on nipple for clockwise rotation to secure piping to pump.
- f. Position pump assembly and piping on baseplate (13).
- g. Connect pump assembly (21) to motor (12) at coupling (11).
- h. Position shaft bracket (6) over mounting screw holes in baseplate.
- i. Secure shaft bracket with four hexhead capscrews (16), lockwashers (15) and hex plain nuts (14).
- j. Position coupling guard (10) on baseplate with mounting screw holes aligned.
- k. Secure coupling guard with two hexhead capscrews (9), lockwashers (8) and hex plain nuts (7).
- l. Install pump relief elbow (25) on pump. Position pipe wrench on elbow for clockwise rotation to secure nipple (27) and valve (1) section pump.
- m. Connect pump relief piping at connector (2).
- n. Connect suction piping at union (4) on inlet side of pump.
- o. Connect discharge piping at union (17) on outlet side of pump.
- p. Open pump relief valve (1).
- q. Open pump suction (3) and discharge (18) valves.
- r. Remove tag and restore power to pump unit.
- s. Run to test.

NOTE

Paragraph 2-109 not applicable to vessels with OWS upgrade, MWO 55-1905-223-55-6. Reference TM 55-1905-223-24-19 for information for vessels that have the OWS upgrade MWO 55-1905-223-55-6 installed.

---

**2-109. Replace Alternating Current Motor (Dirty Oil Rotary Pump Unit).**

---

This task covers: a. Removal, b. Replacement.

---

**INITIAL SETUP**

Tools

Tool Kit, General Mechanic's,  
5180-00-699-5273

General Safety Instruction

Electrical power to pump unit turned  
OFF and tagged "Out of Service - Do  
Not Operate."

Materials/Parts

Alternating current motor, P/N S55  
Warning Tag, Item 1, Appendix C

Appropriate valves closed and tagged  
"Out of Service - Do Not Operate."

---

**REMOVAL/REPLACEMENT**

Refer to paragraph 2-107 for removal/replacement of alternating current motor.

**2-110. Replace/Repair Centrifugal Pump Unit (Reduction Gear Cooling Water).  
(FIGURE 2-90)**

This task covers: a. Removal, b. Repair, c. Replacement.

**INITIAL SETUP**

**Tools**

Tool kit, general mechanic's  
5180-00-699-5273  
Tool kit, electrician's,  
5180-00-391-1087

**Equipment Condition**

Electrical power to pump units  
(PORT/STBD) turned OFF at  
auxiliary machinery motor control  
center and tagged "Out of Service -  
Do Not Operate."  
Pump assembly valve closure:  
PORT - suction (FWC-20)  
Return to keel cooler (FWC-18)  
STBD - Suction (FWC-21)  
Return to keel cooler (FWC-19)  
Closed valves tagged "Out of Service -  
Do Not Operate."

**Materials/Parts**

Centrifugal pump unit  
P/N SMP 2000  
Alternating current motor  
P/N 0743  
Warning tags, Item 1, Appendix C

**REMOVAL**

- a. Tag and disconnect electrical leads at junction box (1) on motor (2).
- b. Close pump suction and discharge valves.
- c. Disconnect discharge piping at union located on top of pump (3).
- d. Disconnect suction piping at union on front end of pump.
- e. Remove four hex plain nuts (7), lockwashers (6), washers (5) and hexhead capscrews (4) securing motor baseplate (8) to foundation.
- f. Remove pump and motor.
- g. Remove adapter and attached fittings from pump casing.
- h. Remove nipple and attached fittings from top of pump.'

**REPAIR**

Repair of centrifugal pump unit consists of replacing motor (2) and pump (3).

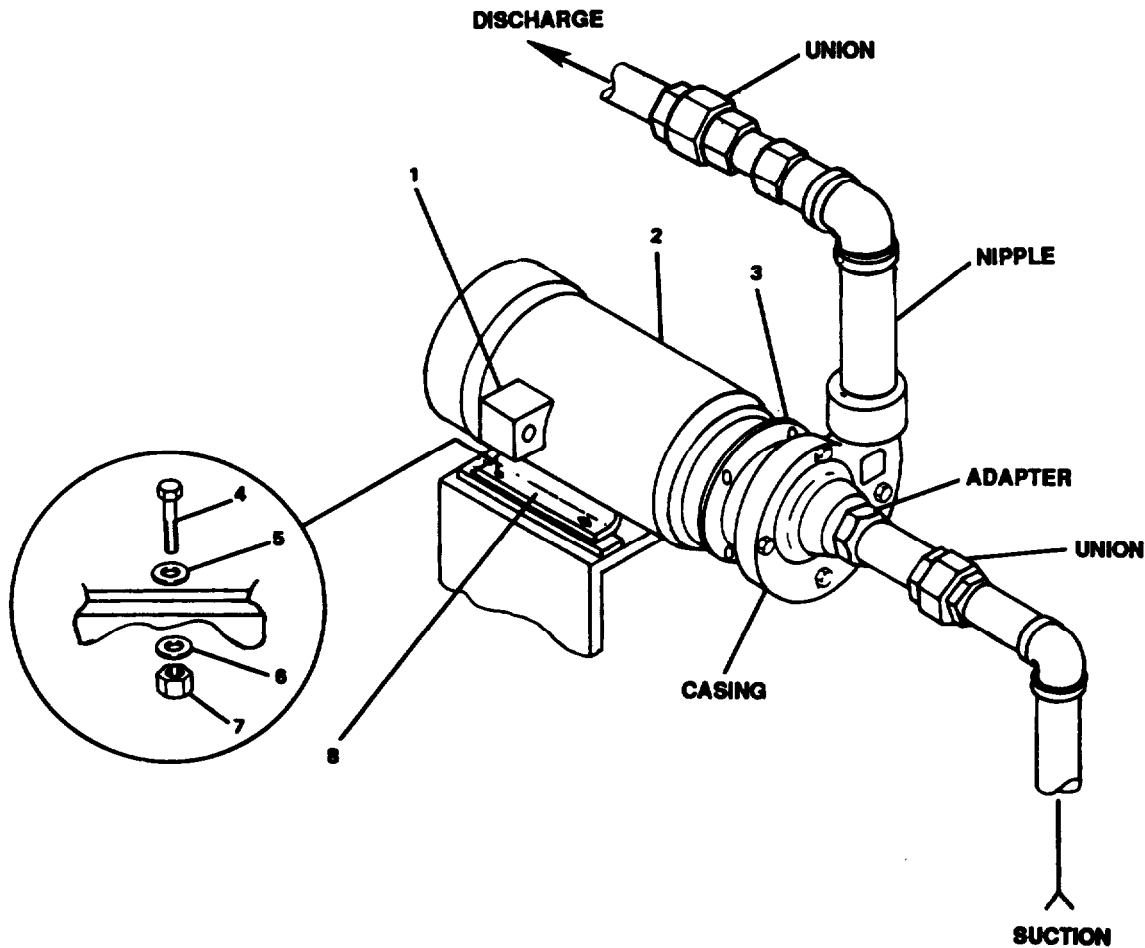


FIGURE 2-90. Pump Assembly (Reduction Gear Cooling Water).

**REPLACEMENT**

- a. Install nipple with attached fittings at top of pump (3).
- b. Install adapter with attached fittings on pump casing.
- c. Position pump and motor baseplate (8) on foundation with mounting screw holes aligned.
- d. Secure motor (2) to foundation with four hexhead capscrews (4), washers (5) lockwashers (6) and hex plain nuts (7).
- e. Connect suction piping at union on front end of pump.
- f. Connect discharge piping at union located on top of pump.
- g. Open pump suction and discharge valves.
- h. Remove tag and connect electrical leads at junction box (1) on motor.
- i. Restore power to pump assembly.

**2-111. Replace Alternating Current Motor (Reduction Gear Cooling Water Centrifugal Pump Unit).**

This task covers: a. Removal, b. Replacement.

**INITIAL SETUP**

**Tools**

Tool kit, general mechanic's,  
5180-00-699-5273  
Tool kit, electrician's,  
5180-00-391-1087

**Materials/Parts**

Alternating current motor  
P/N 0743  
Warning tags, Item 1, Appendix C

**Equipment Condition**

Electrical power to pump units (PORT/STBD) turned OFF at auxiliary machinery motor control center and tagged "Out of Service - Do Not Operate."  
Pump assembly valve closure:  
PORT - Suction (FWC-20)  
Return to keel cooler (FWC-18)  
STBD - Suction (FWC-21)  
Return to keel cooler (FWC-19)  
Closed valves tagged "Out of Service - Do Not Operate."

**REMOVAL/REPLACEMENT**

Refer to paragraph 2-100 for removal/replacement of alternating current motor.

MAINTENANCE OF CONTROLS SYSTEM

---

**2-112. Repair Steering Control and Autopilot System.**

---

This task covers: a. Repair.

---

INITIAL SETUP

Tools

Tool kit, electrician's,  
5180-00-391-1087

Materials/Parts

Warning tags, Item 1, Appendix C

---

Equipment Condition

Electrical power to steering control and autopilot system OFF and tagged "Out of Service - Do Not Operate." (TM 55-1905-223-10).

REPAIR

Repair of the steering control and autopilot system to this level is by repair of the steering control panel assembly (para 2-113), rudder indicator (para 2-114), and junction box assembly (para 2-115).



---

**2-113. Repair Steering Control Panel Assembly. (FIGURE 2-91)**

---

This task covers: a. Disassembly, b. Repair, c. Assembly.

**INITIAL SETUP****Tools**

Tool kit, electrician's,  
5180-00-391-1087

**Materials/Parts**

Incandescent lamps P/N 410-002  
Lamp cover P/N 411-018  
Warning tags, Item 1, Appendix C

**Equipment Condition**

Electrical power to steering control  
and autopilot system OFF and tagged  
"Out of Service - Do Not Operate."  
(TM 55-1905-223-10).

**DISASSEMBLY**

- a. Remove lamp covers (1) from the rear of panel.
- b. Remove incandescent lamp (2).

**REPAIR**

Repair at this level of maintenance is by replacement of lamp covers (1) and incandescent lamps (2).

**ASSEMBLY**

- a. Install new incandescent lamps (2).
- b. Install lamp covers (1) in rear of panel.

---

## 2-113.1 Repair Steering Control Panel (EMI) (FIGURE 2-91.1)

---

This task covers: a. Disassembly, b. Repair, c. Assembly

---

### INITIAL SETUP

#### Tools

Tool kit, electrician's  
5180-00-392-2895

#### Equipment Condition

Electrical power to steering control and autopilot system OFF and tagged "Out of Service - Do not Operate."  
(TM 55-1905-223-10)

#### Materials/Parts

Warning tags, Item 1, Appendix C  
Lamps, P/N 386L

---

### DISASSEMBLY

- a. Remove four mounting screws (1).
- b. Lift unit enough to gain access to the rear of the front panel.
- c. Remove lamps (2).

### REPAIR

Repair at this level of maintenance is by replacement of lamps (2).

### ASSEMBLY

- a. Install new lamps (2).
- b. Lower unit into console.
- c. Install four mounting screws (1).

Hulls 2008 and subsequent

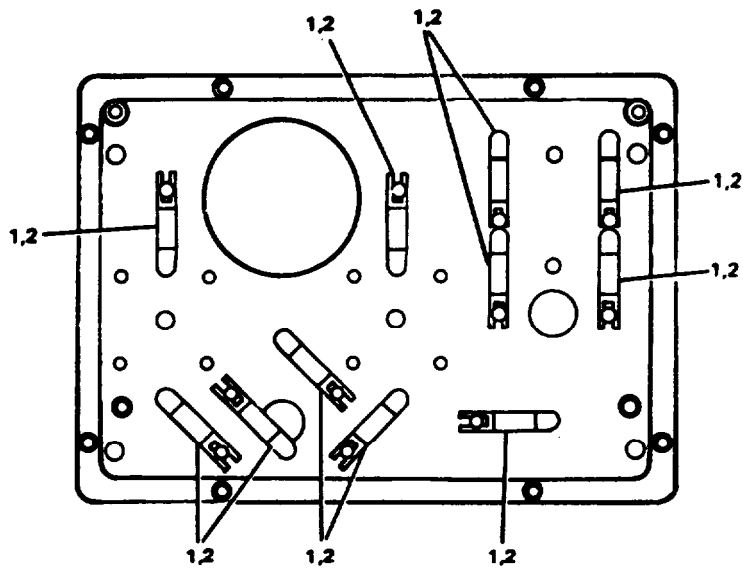


FIGURE 2-91. Steering Control Panel Assembly.

Hulls 2008 and subsequent

Change 2

2-448.1

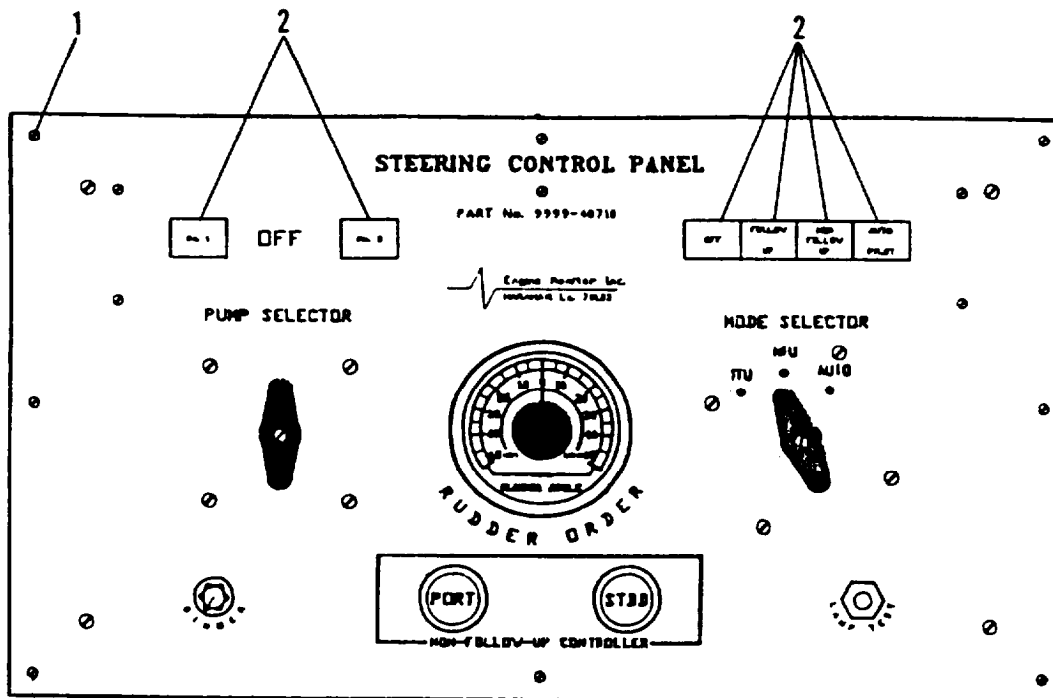


Figure 2-91.1. Steering Control Panel  
Hulls 2008 and subsequent

---

**2-114. Repair Rudder Indicator. (FIGURE 2-92)**

---

This task covers: a. Disassembly, b. Repair, c. Assembly.

---

**INITIAL SETUP****Tools**

Tool kit, electrician's,  
5180-00-391-1087

**Equipment Condition**

Electrical power to steering control  
and autopilot system OFF and tagged  
"Out of Service - Do Not Operate."  
55-1905-223-10).

**Materials/Parts**

Incandescent lamps P/N 410-002  
Cartridge fuse P/N 420-001 (3)  
Warning tags, Item 1, Appendix C

---

**DISASSEMBLY**

- a. Remove cable gland (3) and washer (2).
- b. Remove three capscrews (6) and remove back plate (5).
- c. Remove incandescent lamp (7).
- d. Remove cartridge fuse (4).

**REPAIR**

Repair at this level of maintenance is by replacement of cartridge fuses (4) and incandescent lamps (7).

**ASSEMBLY**

- a. Install new incandescent lamps (7) in each rudder indicator.

**CAUTION**

Make sure new fuses are of the same rating  
as ones being replaced.

- b. Install lamp covers (1) in rear of panel.
- c. Install back plate (5) onto rudder indicator (1). Secure with three capscrews (6).

- d. Install washer (2) and cable gland (3).

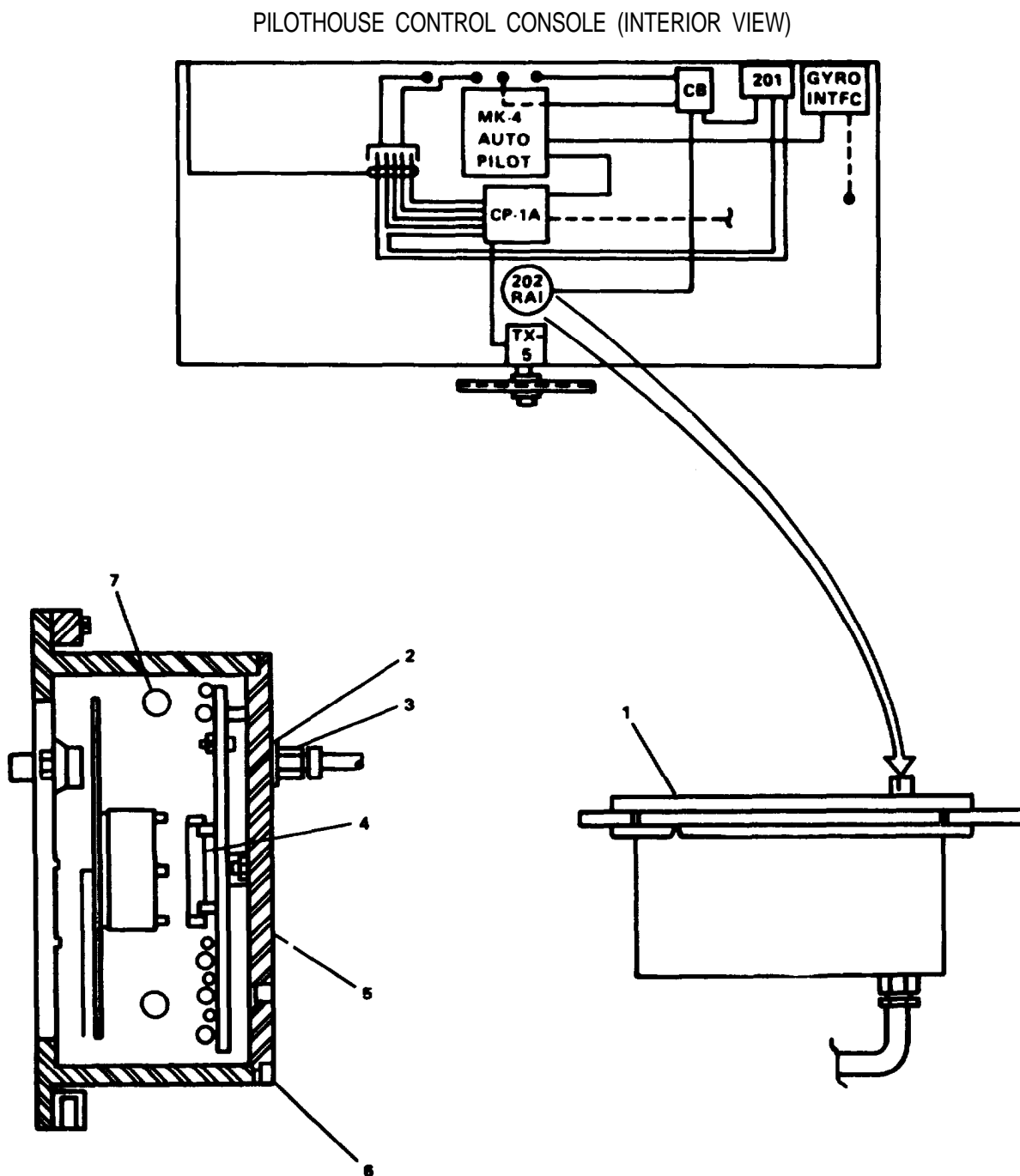


FIGURE 2-92. Rudder Indicator. Pilothouse Console.

---

**2-115. Repair Junction Box Assembly. (FIGURE 2-93)**

---

This task covers: Repair.

---

**INITIAL SETUP****Tools**

Tool kit, electrician's,  
5180-00-391-1087

**Materials/Parts**

Cartridge fuse, P/N 420-001  
Warning tags, Item 1, Appendix C

**Equipment Condition**

Electrical power to steering control  
and autopilot system OFF and tagged  
"Out of Service - Do Not Operate,"  
TM 55-1905-223-10.

**REPAIR**

- a. Open door on pilothouse console.
- b. Unfasten door latches (2) and open door (3) by swinging to the left.
- c. Remove fuses (5) from fuse clips (4).

**NOTE**

Make sure replacement fuses are of the same  
ratings as ones taken out.

- d. Install new fuses (5) in fuse clips (4).
- e. Swing door (3) to the right and secure latches (2) on right side of junction box (1).
- f. Close access door on pilothouse console.
- g. Restore power to pilothouse control console and remove warning tags.

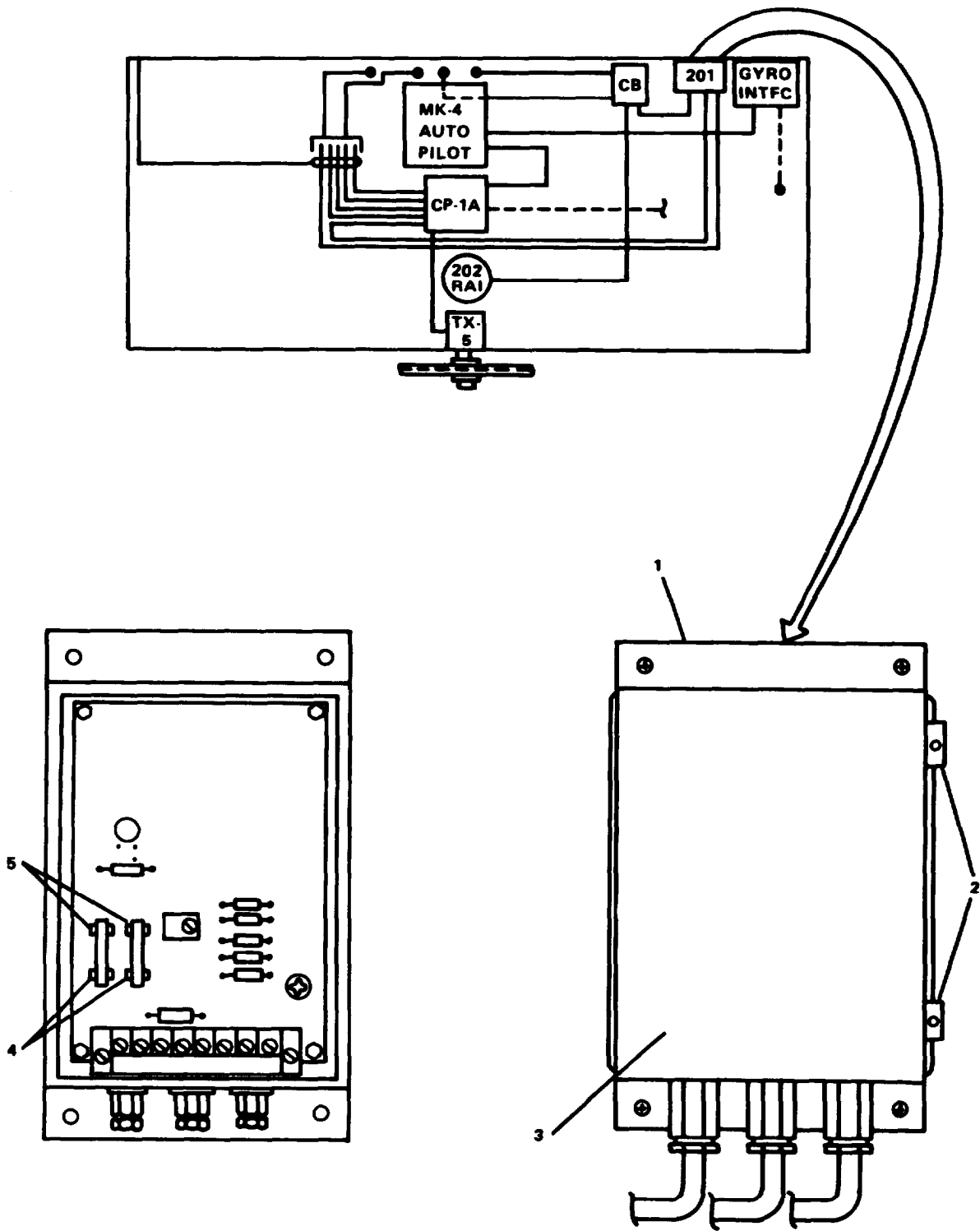


FIGURE 2-93. Junction Box Assembly



---

## 2-116. Replace/Repair Two Station Twin Engine with Bowthruster and Fire Control System.

---

This task covers: a. Inspection, b. Removal, c. Repair, d. Replacement.

---

### INITIAL SETUP

#### **Tools**

Tool kit, general mechanic's,  
5180-00-699-5273

#### **Materials/Parts**

Venturi meter P/N H032-62  
Linear directional valve P/N MOOO-20362  
Warning tags, Item 1, Appendix C  
Teflon tape, Item 5, Appendix C  
Liquid leak detector, Item 36,  
Appendix C

#### **Equipment Condition**

Electrical power and air pressure to pilothouse control console secured and tagged "Out of Service - Do Not Operate."  
Access panel to pilothouse control console removed (para. 2-115).

---

### **INSPECTION**

- a. Operate the system, observe the function for normal operation, AHEAD and ASTERN. Recommended system supply pressure, 120 psi.
- b. During operation check for air leaks at tube fittings, valves and actuator seals by using liquid leak detector. Ensure all tubing is secured and insulated from excessive vibration; check all flexible hoses for checking, aging, or chafing.
- c. With the system actuated AHEAD, inspect the following, then check again while actuated ASTERN.
  - (1) The 3-position gear actuator cylinder should move freely without binding or twisting. The same is true for the governor actuator. Check all linkages and adjustments for correct alignment.
  - (2) Check all pivot points for freedom of movement, excessive wear and corrosion.
  - (3) Check valve indicator pins or stem positions to be sure all are in proper sequence. (Refer to Table 2-3).
  - (4) Recheck all operating pressures for normal settings. (Refer to TM 55-1905-223-10, Operator's Manual.)

- (5) Check all system components for cleanliness. Care must be exercised to insure that excessive dust, dirt, and foreign objects are not allowed to build up around and/or on any of the system components.
- (6) Turn the system air off at the air prep unit shutoff valve. After all system air has bled out, remove the filter unit bowl, drain it, wipe it clean, inspect the filter element, and reinstall the bowl. Be sure the auto drain float (if used) is positioned properly and the lock ring is in the locked position. Double check the lock ring, then turn the air on slowly to prevent shock to the system.

**REMOVAL**

- a. Remove Venturi Meter. (FIGURE 2-94)

**WARNING**

Make sure air pressure is bled from system prior to disconnecting any tubing to avoid personal injury from escaping pressure.

**CAUTION**

Cap or plug all tube connections when removed to prevent contamination of the system.

- (1) Open access panel to pilothouse control console.
  - (2) Inside pilothouse control console, remove two hex head capscrews (4), slide bracket (3) down on tube (5).
  - (3) Disconnect tube (5) at connection (6).
  - (4) Remove venturi meter (2) from control console (1).
- b. Remove Linear Directional Valve. (FIGURE 2-95)

**WARNING**

Make sure air pressure is bled from system prior to disconnecting any tubing to avoid personal injury from escaping pressure.

**CAUTION**

Cap or plug all tube connections when removed to prevent contamination of the system.

- (1) Inside pilothouse control console, disconnect tubing (3) at connection (4).

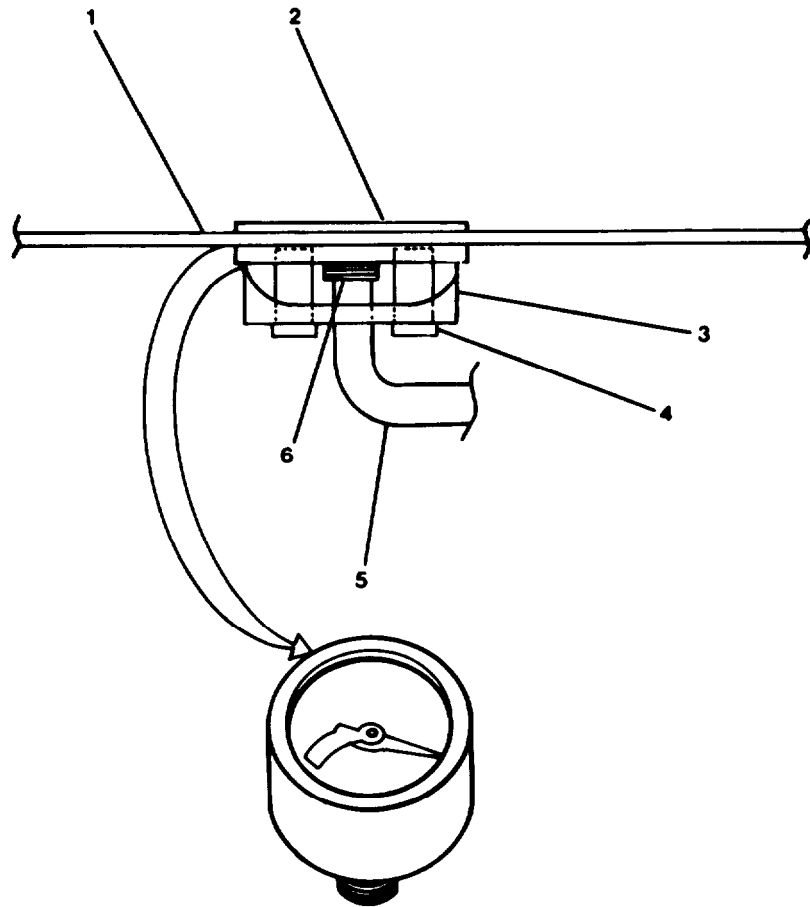


FIGURE 2-94. Venturi Meter, Removal.

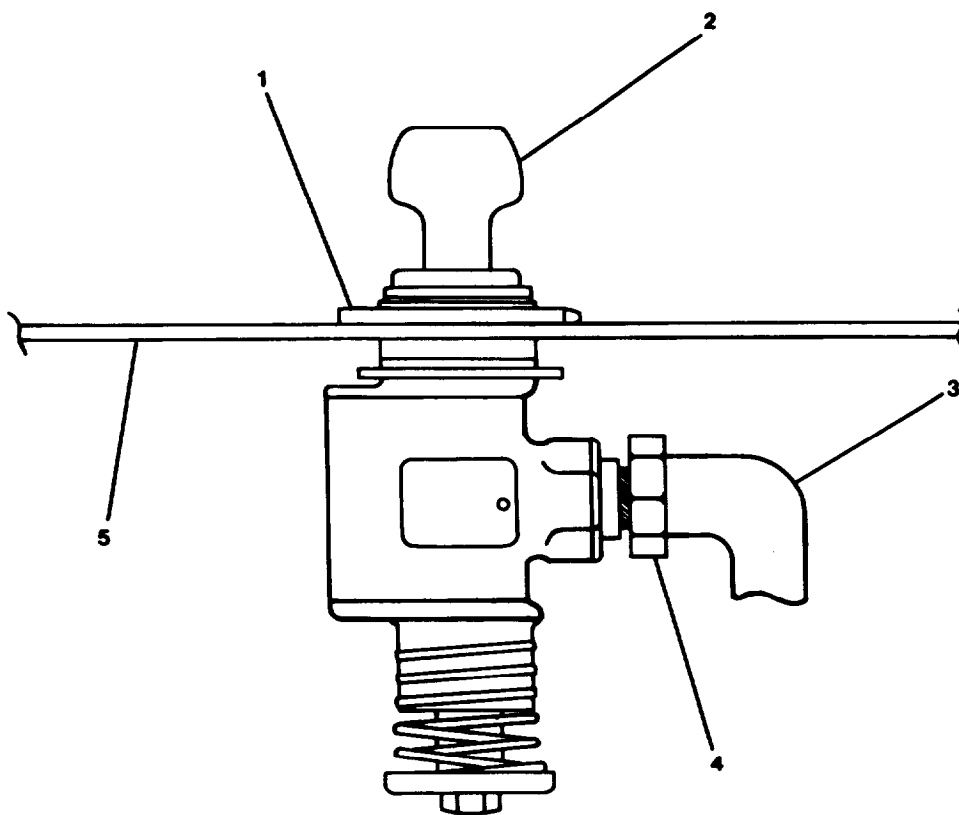


FIGURE 2-95. Linear Directional Valve. Removal.

- (2) Remove hexagon nut (1) securing valve to control console (5).
- (3) Reach inside console and remove linear directional valve (2).

### **REPAIR**

Repair at this level of maintenance is by replacement of venturi meter (2, FIGURE 2-94) and linear directional valve (2, FIGURE 2-95).

### **REPLACEMENT**

- a. Replace Venturi Meter. (FIGURE 2-94)

#### **NOTE**

Prior to connecting tubing, remove caps or plugs from connections.

- (1) Seat Venturi meter (2) in pilothouse control console (1).
- (2) Apply teflon tape to connection (6).
- (3) Connect tube (5) at connection (6).
- (4) Slide bracket (3) up tube (5) and secure to control console with two hex head capscrews (4).

- b. Replace Linear Directional Valve. (FIGURE 2-95)

#### **NOTE**

Prior to connecting tubing, remove caps or plugs from connections.

- (1) Inside control console, push linear directional valve (2) up through console slot.
- (2) Secure to top of console (5) with hexagon nut (1).
- (3) Inside control console, apply teflon tape to connection (4) and connect tubing (3) to linear directional valve.
- (4) Close access panel to pilothouse control console.
- (5) Restore electrical power and air pressure to pilothouse control console.

**2-117. Replace/Repair Directional Control Rotary Valve (Control Station, Pilothouse).**

---

This task covers: a. Removal, b. Disassembly, c. Repair, d. Assembly, e. Test, f. Replacement, g. Adjustment.

---

**INITIAL SETUP**

**Tools**

Tool kit, general mechanic's,  
5180-00-699-5273

**Materials/Parts**

Shuttle valve P/N 03650-9001  
Spring tension washer P/N F023-147  
Thrust bearing washer P/N H257-09  
Roller needle bearing P/N H004-92  
Poppet valve P/N B912-016  
Preformed packing P/N H136-54  
Control station repair kit (for  
complete repair of pilothouse  
control station and engine room  
control station) P/N B732-9101  
Warning tags, Item 1, Appendix C  
Lubriplate No. 107, Item 6, Appendix C  
Teflon tape, Item 5, Appendix C  
Pneumatic grease, Item 7, Appendix C

---

**Equipment Condition**

Air pressure to pilothouse control  
console secured at air prep  
system and tagged "Out of Service -  
Do Not Operate." (TM 55-1905-223-10)

**REMOVAL**

- a. Remove shuttle valve. (FIGURE 2-96)
  - (1) Disconnect tubing (1, 3, and 6) at connections (2, 4, and 7).
  - (2) Remove shuttle valve (8).
  - (3) Unscrew and remove elbow (5).
- b. Remove Directional Control Rotary Valve (Pilothouse Control Station). (FIGURE 2-97).
  - (1) Remove four capscrews (1).
  - (2) Pull directional control rotary valve (2) up and out of control console until flexible hoses are accessible.

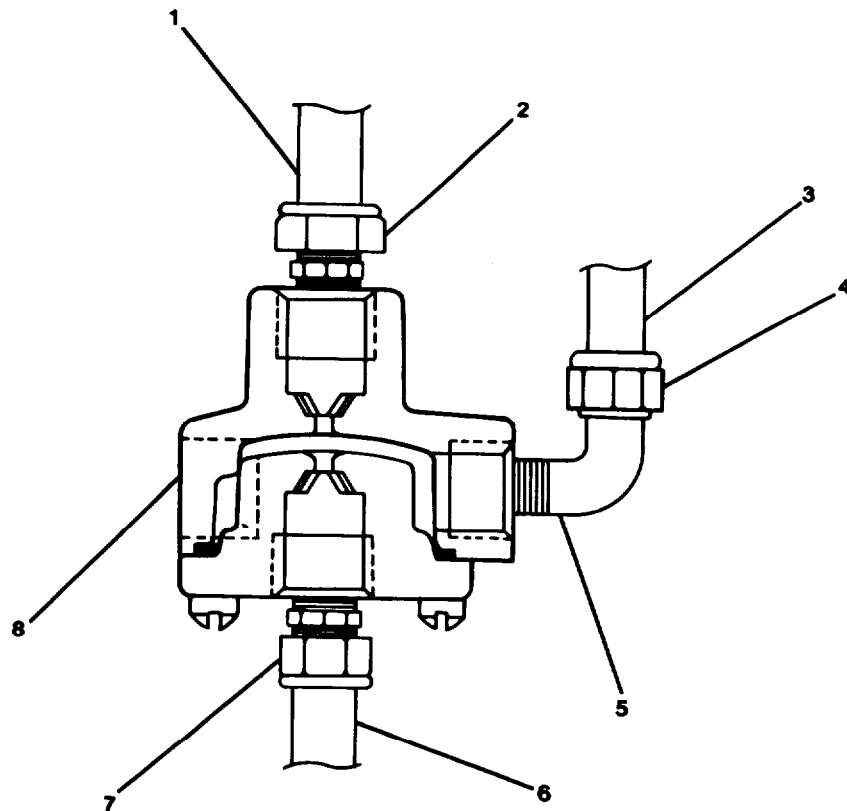


FIGURE 2-96. Shuttle Valve.

- (3) Disconnect and tag flexible hoses at connections (3, 10, and 11).
- (4) Remove directional control rotary valve (2).

DISASSEMBLY (FIGURE 2-97)

- a. Remove hex head screws (9) and lock washers (8).
- b. Remove regulator valve (12).
- c. Remove spring pins (14) from camshaft (7). Remove flat washer (6).
- d. Remove handle (16), camshaft (7) and spring tension washer (13).
- e. Remove spacer (15), thrust washer bearing (4), and roller needle bearing (5).
- f. Remove cap (17) and preformed packing (18).
- g. Remove poppet valve (19).

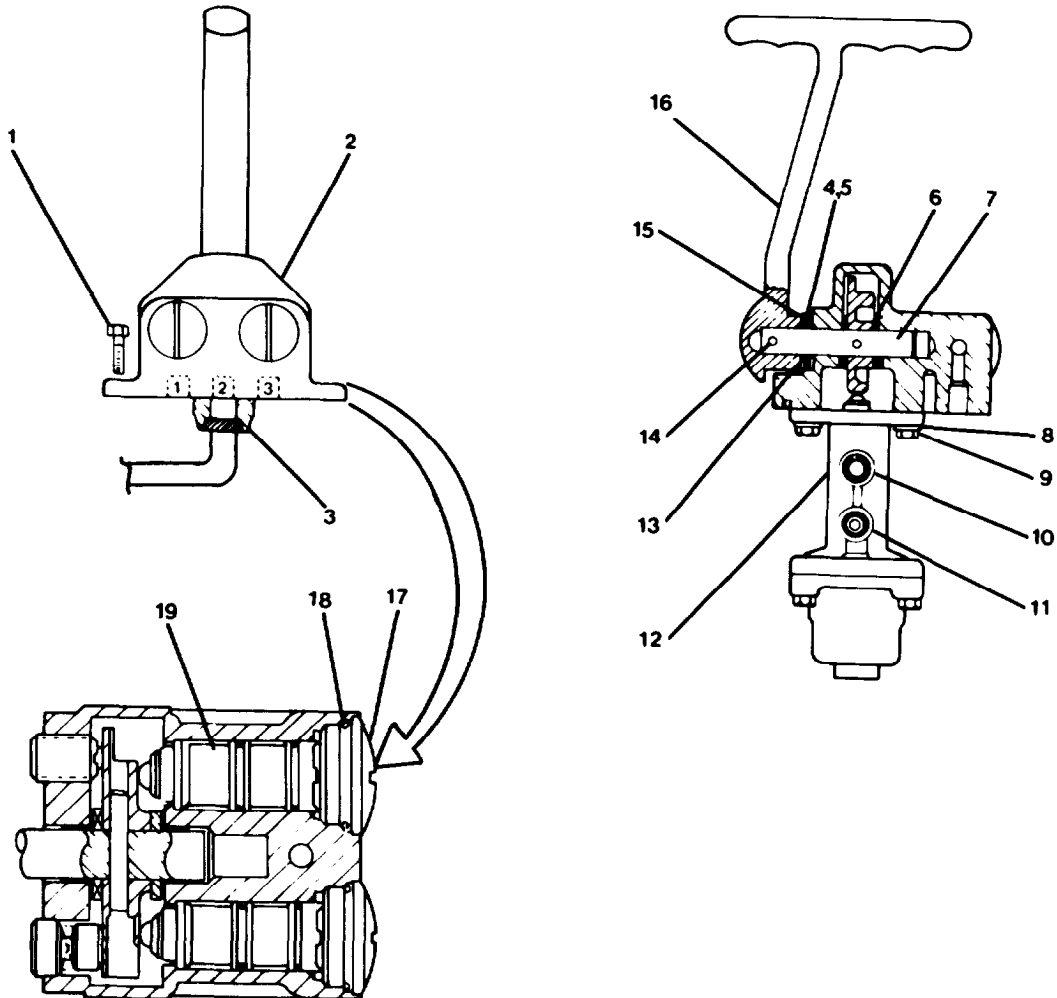


FIGURE 2-97. Directional Control Rotary Valve.

**REPAIR**

Repair at this level of maintenance is by replacement of: shuttle valve (8, FIGURE 2-96), thrust washer bearing (4, FIGURE 2-97), roller needle bearing (5), spring tension washer (13), preformed packing (18), and poppet valve (19).

**NOTE**

Control station repair kit is provided for complete repair of pilothouse and engine room control stations.



ASSEMBLY (FIGURE 2-97)**NOTE**

As component reassembly proceeds, lubricate each part using Lubriplate No. 107 on metal to metal moving surfaces and pneumatic grease on all rubber parts.

- a. Install poppet valve (19).
- b. Install preformed packing (18) and cap (17).
- c. Install spacer (15), roller needle bearing (5). and thrust washer bearing (4).
- d. Install tension spring washer (13) and flat washer (6).
- e. Install camshaft (7) and handle (16).
- f. Secure with spring pins (14).
- g. Install regulator valve (12). Secure with hex head screws (9) and lockwashers (8).

TEST

- a. After cleaning and/or repairs the component must be bench tested to ensure good operation before reinstallation. Check for leaks and smooth operation. Take the precaution of blowing the air line to be reconnected free of any foreign objects; use clean, dry air.
- b. Ensure the components have been properly reinstalled and all linkages and adjustments are properly aligned and set.
- c. Operate the control system. Ahead and then Astern. Observe function of the reinstalled component for freedom of movement, full actuation of controlled engine and reduction gear levers.
- d. Check the repaired component and all fittings for leakage.
- e. Recheck the following:
  - (1) Governor Actuator - actuate the control station to full Astern. In both conditions the throttle lever or fuel rack must move to the full throttle position. When the control station is returned to the neutral or idle position, the throttle lever should immediately return to the idle position.
  - (2) 3-Position Reduction Gear Actuator - move the control station to the Ahead position; check the adjustment to be sure the Ahead clutch is being selected and the selector lever is fully actuated. Repeat this test for Astern clutch selection. When the control station is returned to the neutral position, the reduction gear clutches must disengage immediately.

The reduction gear clutch selector lever must be in the neutral position with no binding or load applied.

REPLACEMENT

- a. Replace Directional Control Rotary Valve (Pilothouse Control Station).  
(FIGURE 2-97)
  - (1) Connect flexible hoses at connections (3, 10, and 11). Remove tags.
  - (2) Install directional control rotary valve (2) in pilothouse control console. Secure with four capscrews (1).
- b. Install Shuttle Valve. (FIGURE 2-96)
  - (1) Screw elbow (5) into shuttle valve.
  - (2) Position shuttle valve (8) for connection to tubing.
  - (3) Connect tubing (1, 3, and 6) at connections (2, 4, and 7).
- c. Restore air pressure to pilot house control console. Remove tags.

ADJUSTMENT (FIGURE 2-98)

- a. Pressure Setting Adjustment. Hex adjusting screw on the pressure regulator varies the maximum and minimum pressure setting the same amount. Turning the screw "IN" raises the maximum and minimum pressure at the pressure regulator "OUT" port, turning it out will decrease maximum and minimum pressure. To make adjustment, first plug ports 1 and 3, place an air gauge in pressure regulator "OUT" port, and connect 120 psi supply to the inlet connection, Move the handle to maximum pressure position, then turn adjusting screw in or out until required pressure is seen on the pressure gauge.
- b. Friction Drag Adjustment. Handle force of the control station can be varied by adjusting hex set screw. This adjustment increases or decreases the manual force required to move or hold the handle in any desired position. Facing the handle side, a clockwise rotation will increase the friction drag.
- c. Handle Detent Adjustment. The detent force of the control station lever can be varied by adjustment detent screw. This adjustment increases or decreases the manual forces required to remove the handle from a detented position. Facing the handle side clockwise rotation of screw will increase detent force.

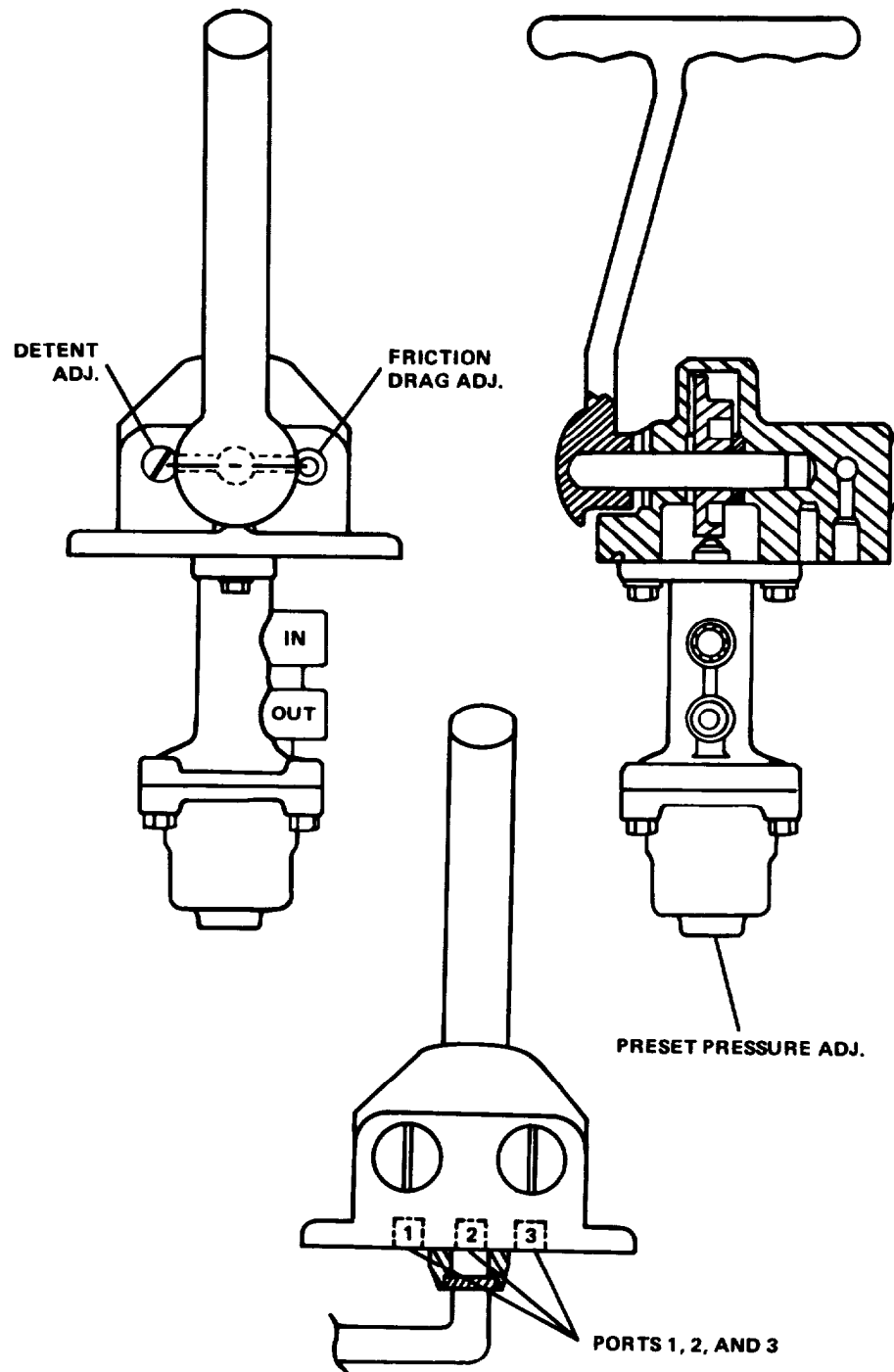


FIGURE 2-98. Directional Control Rotary Valve. Adjustment.

## 2-118. Replace/Repair Engine Room Control Station.

---

This task covers: a. Removal, b. Disassembly, c. Repair, d. Assembly, e. Test, f. Replacement, g. Adjustment.

---

### INITIAL SETUP

#### Tools

Tool kit, general mechanic's,  
5180-00-699-5273

#### Materials/Parts

Spring tension washer P/N F023-147  
Thrust washer bearing P/N H257-09  
Roller needle bearing P/N H004-92  
Sleeve bearing P/N H004-115  
Poppet valve P/N B912-016  
Preformed packing P/N H136-54  
Venturi meter P/N H032-62  
Four-way directional valve  
P/N F041-0003  
Pneumatic grease, Item 7, Appendix C  
Lubriplate No. 107, Item 6, Appendix C  
Teflon tape, Item 5, Appendix C  
Warning tags, Item 1, Appendix C

---

#### Equipment Condition

Air pressure to engine room control station secured at the air prep system and tagged "Out of Service - Do Not Operate." (TM 55-1905-223-10) For TEST and ADJUSTMENT procedure, refer to para. 2-117. Venturi meter removal procedure is the same as para. 2-116.

### REMOVAL

- a. Remove Engine Room Control Station.
  - (1) Remove 12 machine bolts (2, FIGURE 2-99).
  - (2) Remove access panel (3) from engine room control console (1) stbd side.
  - (3) Remove four machine bolts (2, FIGURE 2-100).
  - (4) Inside console remove lo&washers (3) and nuts (4).
  - (5) Lift control station (1) up and out of console until flexible hoses are accessible.
  - (6) Tag and disconnect flexible hoses at ports (11, 12, and 13).
  - (7) Cap or plug connections.
  - (8) Remove control station (1).

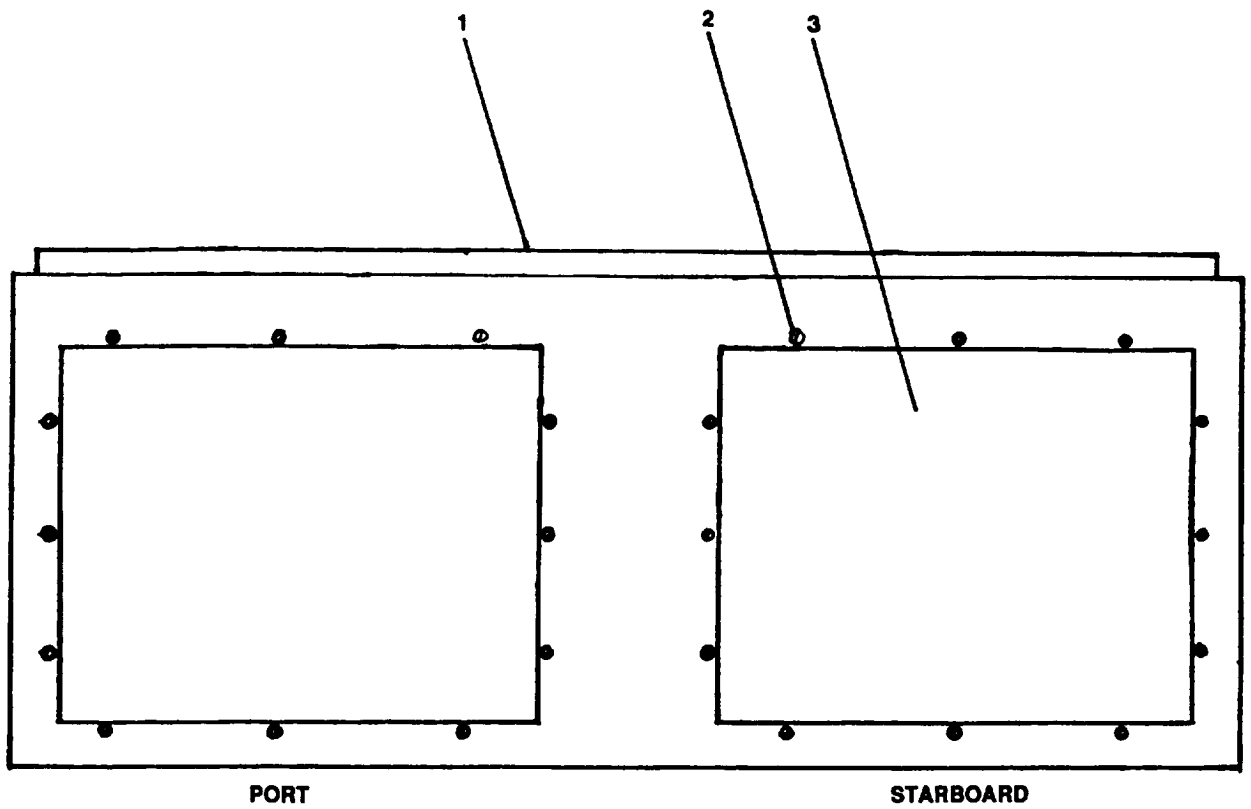


FIGURE 2-99. Engine Room Control Console.

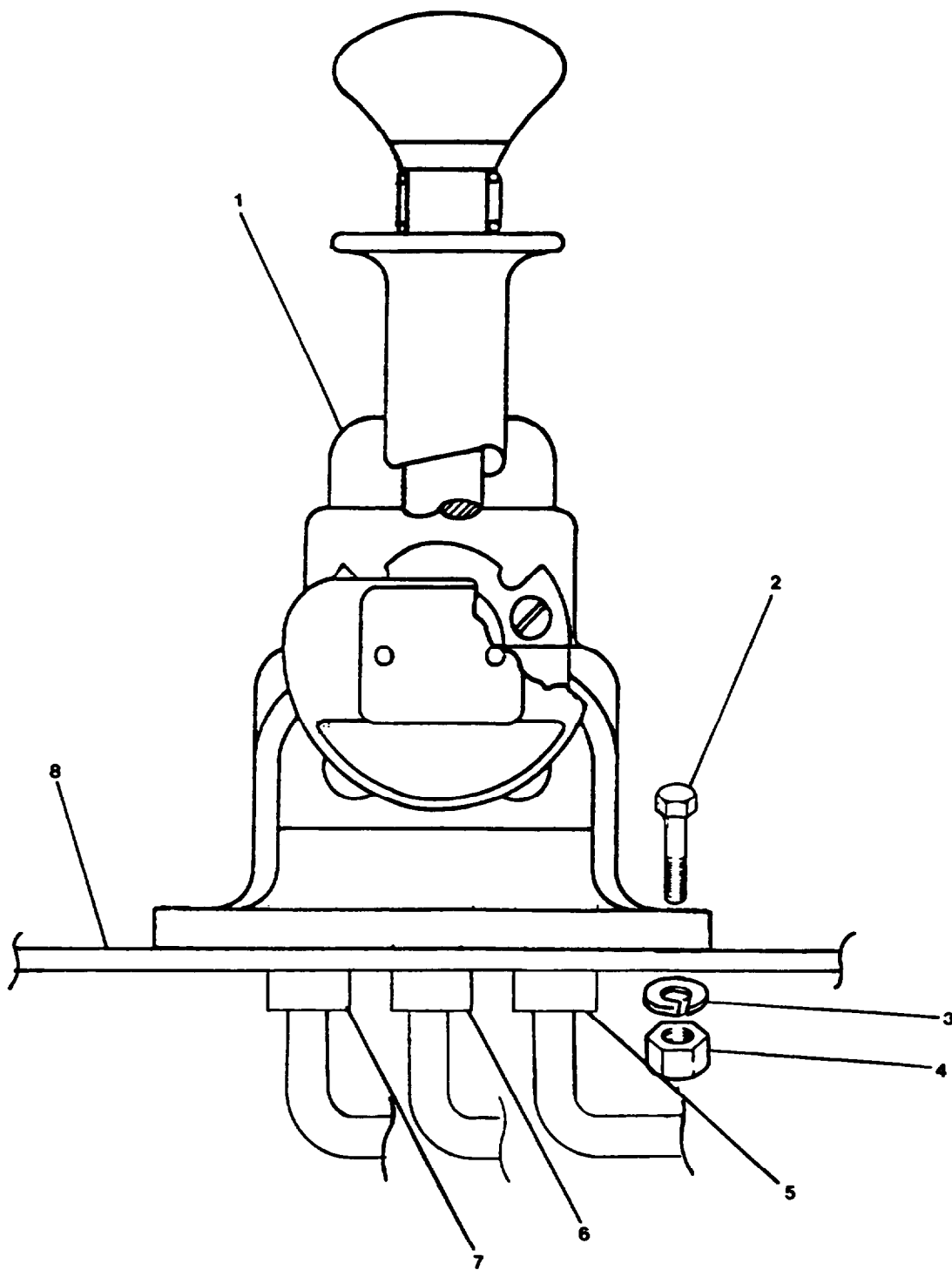


FIGURE 2-100. Four-Way Directional Valve.

## b. Remove Four-Way Directional Valve

- (1) Engine room control console access panel removed in step a.(1) and (2).
- (2) Remove four machine bolts (2, FIGURE 2-100).
- (3) Inside console remove lockwashers (3) and nuts (4).
- (4) Lift valve (1) up and out of console until flexible hoses are accessible.
- (5) Tag and disconnect flexible hoses at ports (5, 6, and 7).
- (6) Cap or plug connections.
- (7) Remove four-way directional valve (1) from console (8).

DISASSEMBLY

- a. Remove hex head screws and lockwashers (15, 16, FIGURE 2-101).
- b. Remove valve regulator (14).
- c. Remove spring pins (18) from camshaft.
- d. Remove handle (19) and camshaft (10).
- e. Remove sleeve bearing (23).
- f. Remove flat washer (9) and spring tension washer (17).
- g. Remove spacer (6), thrust washer bearing (7), and roller needle bearing (8).
- h. Remove cap (20), preformed packing (21), and poppet valve (22).

REPAIR

Repair at this level of maintenance is by replacement of venturi meter, four-way directional valve (1), thrust washer bearing (7), roller needle bearing (8), spring tension washers (17), preformed packing (21), poppet valve (22), and sleeve bearing (23).

ASSEMBLY**NOTE**

As component reassembly proceeds, lubricate each part using lubriplate no. 107 on metal to metal moving surfaces and pneumatic grease on all rubber parts.

- a. Install poppet valve (22), preformed packing (21) and cap (20).
- b. Install roller needle bearing (8), thrust washer bearing (7), and spacer (6).

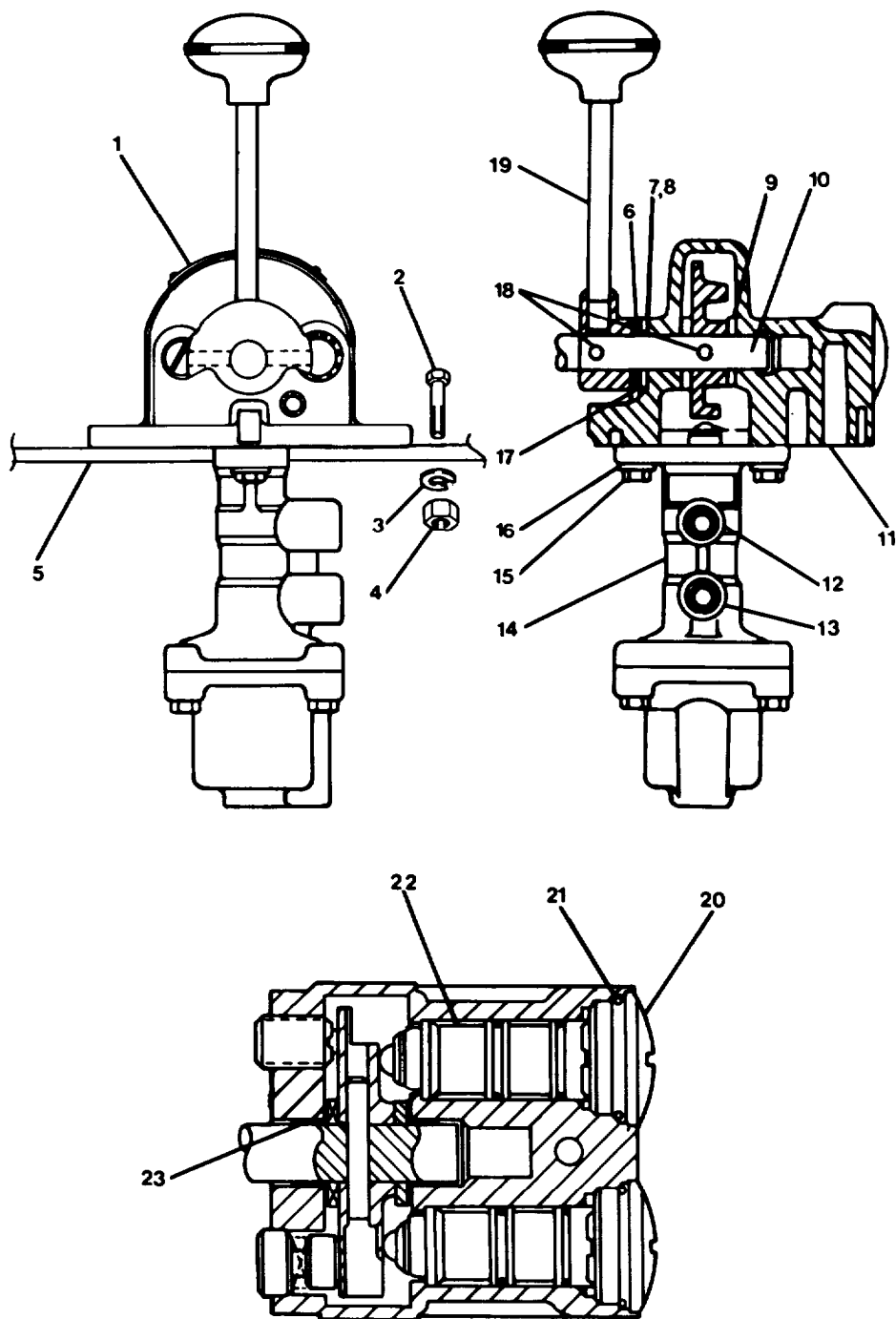


FIGURE 2-101. Engine Room Control Station.



- c. Install flat washers (9) and spring tension washer (17).
- d. Install sleeve bearing (23).
- e. Install camshaft (9) and handle (19).
- f. Install spring pins (18) in camshaft.
- g. Install valve regulator (14); secure to upper portion of control station with hex head screws (15) and lockwashers (16).

#### REPLACEMENT

- a. Replace Four-Way Directional Valve.
  - (1) Remove caps or plugs from connections.
  - (2) Apply teflon tape to connections; connect flexible hoses at ports (5, 6, and 7, FIGURE 2-100).
  - (3) Position valve in slot in engine room console.
  - (4) Replace four machine bolts (2).
  - (5) Inside console secure valve with nuts (4) and lockwashers (3).
- b. Replace Engine Room Control Station.
  - (1) Remove caps or plugs from connections.
  - (2) Apply teflon tape to connections connect flexible hoses at ports (11, 12, and 13, FIGURE 2-101).
  - (3) Position control station in slot in engine room console.
  - (4) Replace four machine bolts (2).
  - (5) Inside console secure control station with nuts (4) and lockwashers (3).
  - (6) Replace access panel (3, FIGURE 2-99) and secure to console with 12 machine bolts (2).
  - (7) Restore air pressure to engine room control console and remove tags.

2-119. Replace/Repair Gearmate Control System.

---

This task covers: a. Removal, b. Disassembly, c. Repair, d. Assembly,  
e. Replacement, f. Adjustment.

---

INITIAL SETUP

Tools

Tool kit, general mechanic's,  
5180-00-699-5273

Materials/Parts

Three-way valve P/N N404-31-093  
Seal P/N H142-19  
Preformed packing P/N H239-25  
Helical compression spring P/N F023-167  
Preformed packing P/N H134-14  
Poppet valve P/N B912-016  
Preformed packing P/N H136-54  
Shuttle valve P/N 03650-9001  
Throttle interlock repair kit (for  
complete repair of throttle  
interlock) P/N B732-934  
Warning tags, Item 1, Appendix C  
Teflon tape, Item 5, Appendix C

---

Equipment Condition

Air pressure to gearmate control  
panel secured at air prep system  
and tagged "Out of Service - Do Not  
Operate." (TM 55-1905-223-10)

REMOVAL

**NOTE**

Replacement of gearmate control system is by  
removal and replacement of components in the  
gearmate control system.

- a. Remove Gearmate Control Panel and Three-Way Valve. (FIGURE 2-102).

**WARNING**

Make sure air is bled from system prior to  
removal of components, to prevent personal  
injury from escaping pressure.

- (1) Tag and disconnect copper tubing (2, 3, 7, 9, 12, and 13) at connections  
(1, 4, 6, 10, 11, and 14).

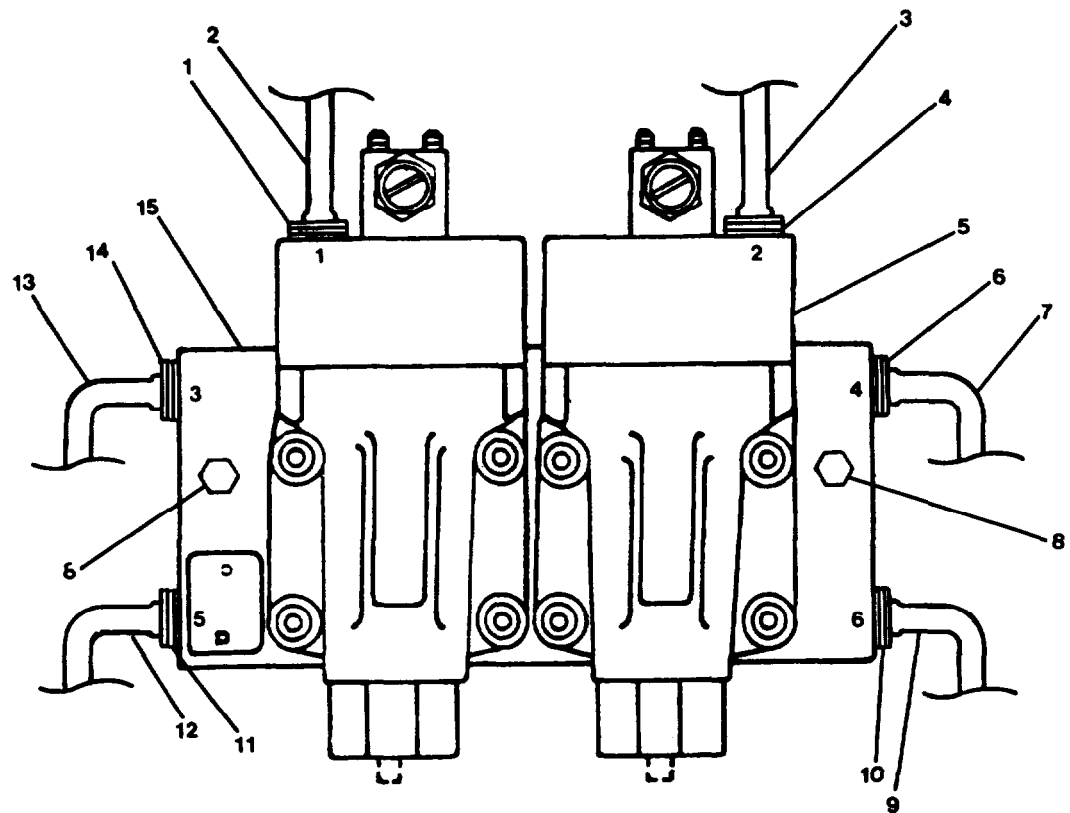


FIGURE 2-102. Gearmate Control Panel Three-Way Valve.

- (2) Cap or plug connections to prevent contamination.
  - (3) Remove machine bolts (8) from manifold plates (15).
  - (4) Remove three-way valves (5).
- b. Remove Throttle Interlock . (FIGURE 2-103)

#### WARNING

Make sure air is bled from system prior to removal of components to prevent personal injury from escaping pressure.

- (1) Tag and disconnect copper tubing at connections (4, 8, 9, 10, and 11).
- (2) Cap or plug connections to prevent contamination.
- (3) Remove mounting screws (5) securing throttle interlock (7) to mounting bracket (6).
- (4) Remove throttle interlock (7).

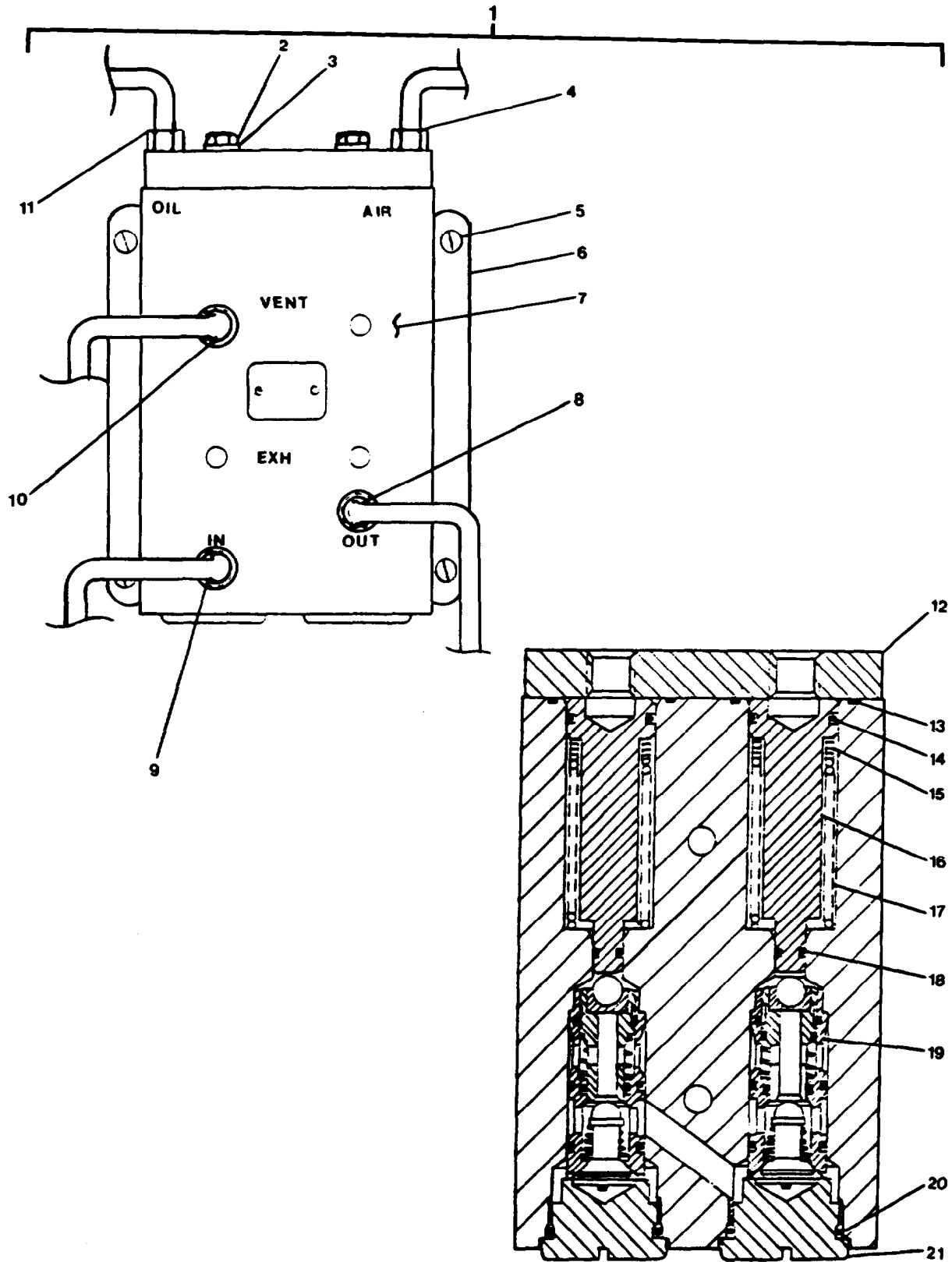


FIGURE 2-103. Throttle Interlock.

c. Remove Shuttle Valves. (FIGURE 2-104)**WARNING**

Make sure air is bled from system prior to removal of components to prevent personal injury from escaping pressure.

- (1) Disconnect tubing (1, 3, and 6) at connections (2, 4, and 7).
- (2) Cap or plug connections to prevent contamination.
- (3) Remove shuttle valve (8).

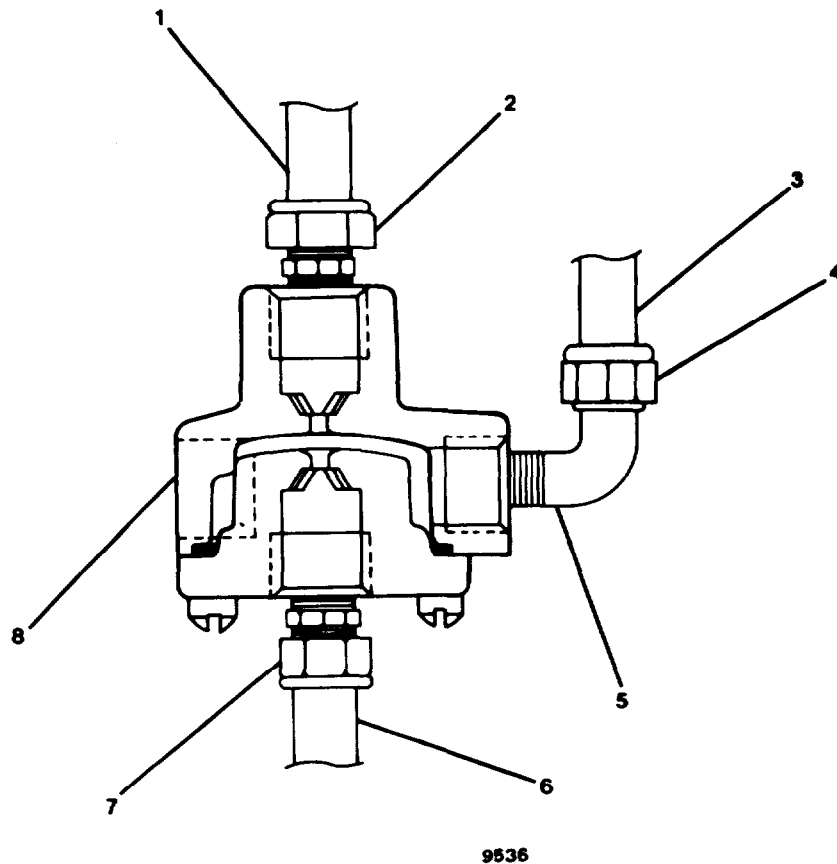


FIGURE 2-104. Shuttle Valve. Removal.

DISASSEMBLY (FIGURE 2-103)

- a. Remove two hex head capscrews (2) and lo&washers (3).
- b. Remove end plate (12).
- c. Remove seal (13) and preformed packing (14).
- d. Remove spacer (15) and piston (16).
- e. Remove helical compression spring (17) and preformed packing (18).
- f. Remove valve cap (21) and preformed packing (20).
- g. Remove poppet valve (19).

REPAIR

- a. Repair at this level of maintenance is by replacement of gearmate control panel, three-way valve (5, FIGURE 2-102), shuttle valve (8, FIGURE 2-104), seal (13, FIGURE 2-103), preformed packing (14), helical compression spring (17), preformed packing (18), preformed packing (20), and poppet valve (19).

**NOTE**

Throttle interlock repair kit is provided for complete repair of throttle interlock.

- b. Wash all rubber parts with soap and water, all other parts with petroleum base solvent, mineral spirits (stoddard solvent) or kerosene. Blow dry all parts with low pressure air. Flex all rubber parts; if hardened, cracked or worn, replace them.

ASSEMBLY (FIGURE 2-103)

- a. Install poppet valve (19).
- b. Install preformed packing (20) and valve cap (21).
- c. Install preformed packing (18) on end of piston (16).
- d. Install helical compression spring (17).
- e. Install spacer (15) and piston (16) on top of helical compression spring.
- f. Install preformed packing (14) and seal (13).
- g. Replace end plate (12) and secure with hex head capscrews (2) and lockwashers (3).

REPLACEMENT

- a. Replace Throttle Interlock. (FIGURE 2-103).
  - (1) Position throttle interlock for mounting and remove caps or plugs.
  - (2) Install throttle interlock (7) on mounting bracket (6). Secure with mounting screws (5).
  - (3) Apply teflon tape to all connections.
  - (4) Connect copper tubing at connections (4, 8, 9, 10, and 11). Remove tags.
- b. Replace Gearmate Control Panel and Three-Way Valves. (FIGURE 2-102).
  - (1) Position three-way valves (5) for mounting and remove caps or plugs.
  - (2) Install three-way valves (5) to manifold plate (15) and secure with machine bolts (8).
  - (3) Apply teflon tape to connections.
  - (4) Connect copper tubing (2, 3, 7, 9, 12, and 13) at connections (1, 4, 6, 10, 11, and 14). Remove tags.
  - (5) Restore air pressure to gearmate control panel. Remove tags.

## ADJUSTMENT (FIGURE 2-105)

- a. To adjust ahead time delay, use valve (1); for Astern timing use valve (2). Loosen the locknut (3) located around the adjustment knob (4). For shorter delay, turn adjustment knob (4) counterclockwise; for longer delay, turn clockwise. After adjustment, tighten the locknut and recheck timing with engine off and system connected, tested and supplied with normal operating pressure (120 psi). Move engine room control station lever to Astern position; let set for 5 seconds; then move the control lever to Ahead position, note neutral time delay, and adjust to valve (1) if required. Reverse this procedure for Astern neutral delay using valve (2) for adjustment.
- b. A red indicator pin (5) will extend from the valve cap on the bottom of the valve when valve (1) or (2) is in time delay mode.

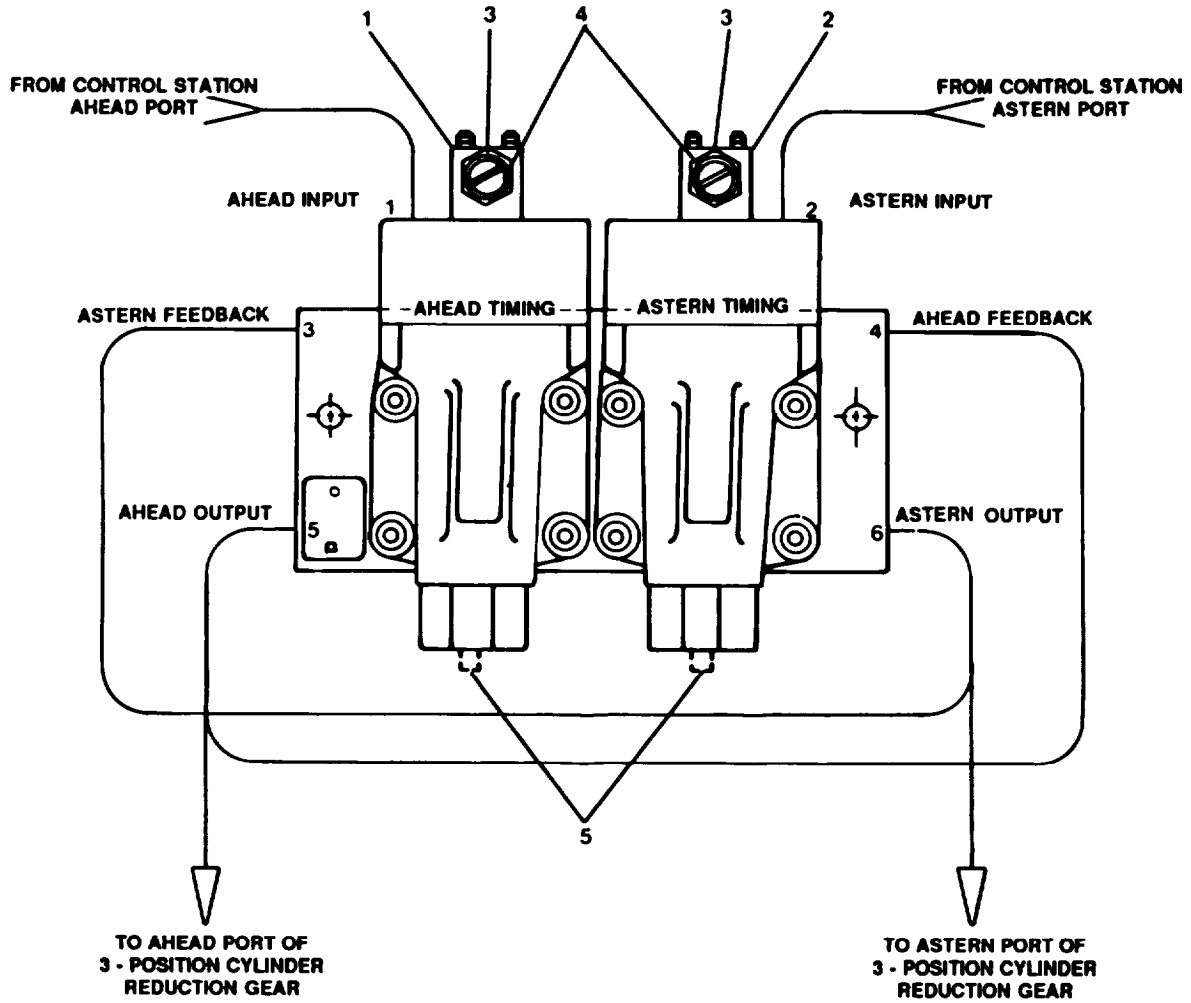


FIGURE 2-105. Three-Way Valve Adjustment.



---

## 2-120. Replace/Repair Gearmate Control Panel.

---

This task covers: a. Removal, b. Disassembly, c. Repair, d. Assembly, e. Replacement, f. Adjustment.

---

### INITIAL SETUP

#### Tools

Tool kit, general mechanic's,  
5180-00-699-5273

#### Materials/Parts

Three-way valve P/N N404-31-093  
Seal P/N H142-19  
Prefomed packing P/N H239-25  
Helical compression spring P/N F023-167  
Prefomed packing P/N H134-14  
Poppet valve P/N B912-016  
Prefomed packing P/N H136-54  
Shuttle valve P/N 03650-9001  
Throttle interlock repair kit (for  
complete repair of throttle  
interlock) P/N B732-934  
Warning tags, Item 1, Appendix C  
Teflon tape, Item 5, Appendix C

#### Equipment Condition

Air pressure to gearmate control  
panel secured at air prep system  
and tagged "Out of Service - Do Not  
Operate." (TM 55-1905-223-10)

---

### NOTE

Refer to paragraph 2-119 for replace/repair  
of the gearmate control panel.

2-121. Replace/Repair Air Preparation System. (FIGURE 2-106)

---

This task covers: a. Removal, b. Disassembly, c. Repair, d. Assembly, e. Replacement.

---

INITIAL SETUP

Tools

Tool kit, general mechanic's,  
5180-00-699-5273

Materials/Parts

Air preparation system P/N F011-120  
Venturi meter P/N H032-62  
Safety relief valve P/N H172-106  
Ball valve P/N H172-105  
Fluid pressure filter parts kit  
(for complete repair of air  
preparation system) P/N B732-920  
Warning tags, Item 1, Appendix C  
Teflon tape, Item 5, Appendix C

Equipment Condition

CA-1 control air cut-out at compressed  
air manifold secured and tagged  
"Out of Service - Do Not Operate."  
(TM 55-1905-223-10)

---

REMOVAL

- a. Disconnect and cap or plug tubing (5) from exhaust ball valve (4).
- b. Disconnect and cap or plug tubing (12) from intake valve (13).
- c. Remove four machine screws (2).
- d. Remove air preparation system (1) from bulkhead.

DISASSEMBLY

- a. Remove nuts (6) and shut-off handles (7).
- b. Remove ball valve (4) from pipe nipple (3).
- c. Remove ball valve (13) from pipe nipple (14).
- d. Loosen jam nut (8) and remove Venturi meter (9).
- e. Remove safety relief valve (10) from nipple (11).

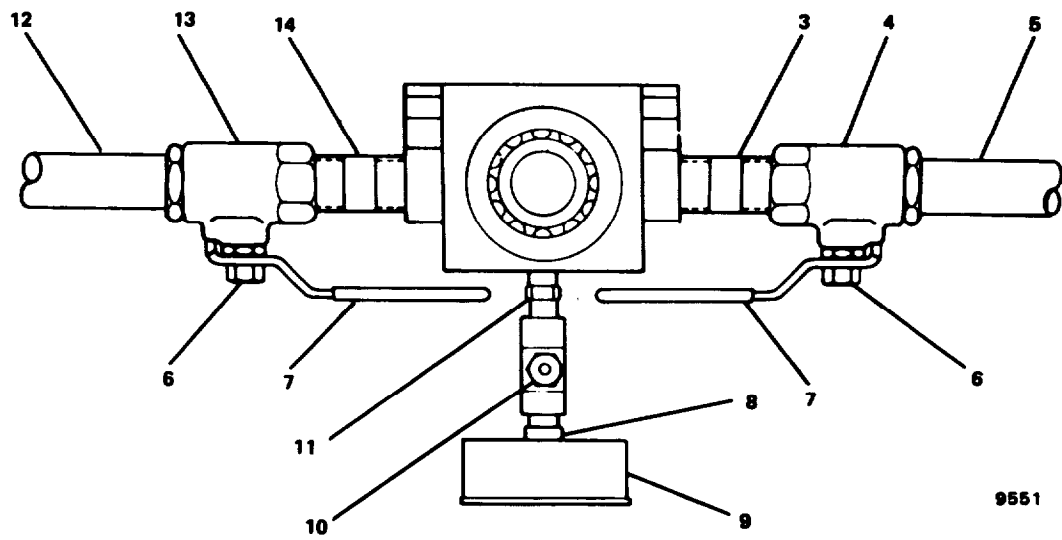
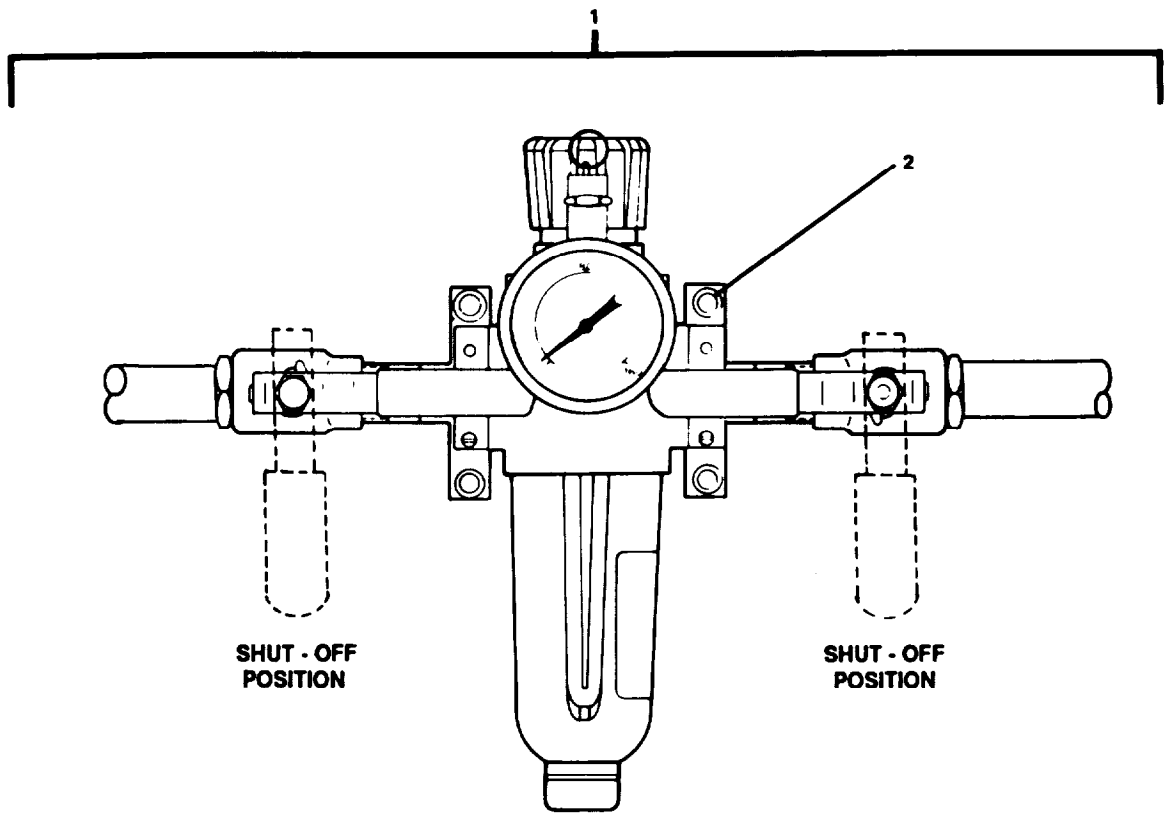


FIGURE 2-106. Air Preparation System.

**REPAIR**

**NOTE**

Repair kit is provided for complete repair of the air preparation system.

- a. Clean rubber parts with soap and water, all other parts with petroleum base solvent, mineral spirits or kerosene. Rinse thoroughly and blow dry with low pressure air.
- b. Check all parts for wear, corrosion or damage.
- c. Repair at this level of maintenance is by replacement of Venturi meter (9), safety relief valve (10), and ball valves (4) and (13).

**ASSEMBLY**

- a. Apply teflon tape to threads of nipple (11) and install safety relief valve (10).
- b. Apply teflon tape to threads on back of Venturi meter (9).
- c. Secure meter to safety relief valve with jam nut (8).
- d. Apply teflon tape to nipple (14) and install intake ball valve (13).
- e. Apply teflon tape to tubing (10) and connect to ball valve (13).
- f. Apply teflon tape to nipple (3) and install exhaust ball valve (4).
- g. Remove caps or plugs from tubing.
- h. Apply teflon tape to tubing (5) and connect to ball valve (4).
- i. Replace shutoff handles (7) and secure with nuts (6).

**REPLACEMENT**

- a. Install air preparation system (1) on bulkhead.
- b. Secure with four machine screws (2).
- c. Connect tubing (12) to intake valve (13).
- d. Connect tubing to exhaust valve (4).
- e. Turn ON air at CA-1 control air cut-out and remove tag.

---

2-122. Replace/Repair System Pressure Regulating Valve. (FIGURE 2-107)

---

This task covers: a. Removal, b. Disassembly, c. Repair, d. Assembly, e. Replacement.

---

### INITIAL SETUP

#### Tools

Tool kit, general mechanic's,  
5180-00-699-5273

#### Materials/Parts

Fluid pressure regulating valve  
P/N 05852-2040  
Dial indicating pressure gage  
P/N 03560-0300  
Panel parts kit (need for complete  
repair of brake panel) P/N B732-687  
Warning tags, Item 1, Appendix C  
Teflon tape, Item 5, Appendix C

---

#### Equipment Condition

Air pressure to brake panel secured at  
air prep system and tagged "Out  
of Service - Do Not Operate."  
(TM 55-1905-223-10)

### REMOVAL

#### **CAUTION**

Vent air pressure from system prior to  
disconnecting tubing to prevent injury to  
personnel by escaping pressures.

- a. Disconnect tubing at adapters (12, 13, and 15) cap or plug tubing.
- b. Remove four machine screws (21).
- c. Remove brake panel assembly (3) from bracket.

### DISASSEMBLY

#### **NOTE**

Cap or plug all tubing/adapters when  
disconnected to prevent contamination from  
entering the system.

- a. Loosen cover latches (2).
- b. Remove panel cover (1) from brake panel (3).

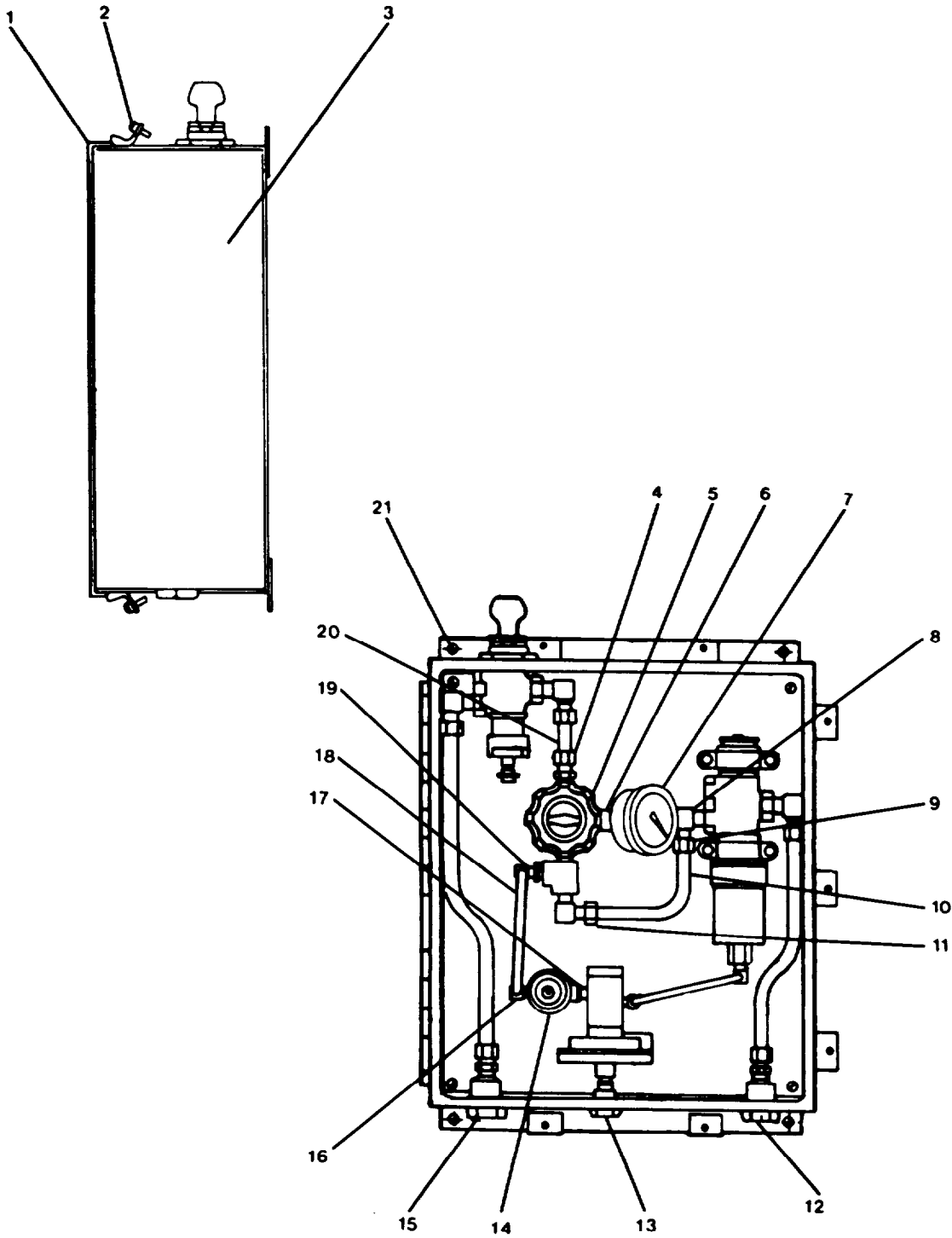


FIGURE 2-107. Brake Panel Assembly.

c. Remove Dial Indicating Pressure Gauge.

- (1) Disconnect and remove tubing (10) at connections (9, 11).
- (2) Disconnect tubing (18) and (20) at connections (19) and (4).
- (3) Unscrew system pressure regulating valve (5) from straight adapter (6).
- (4) Unscrew dial indicating pressure gauge (7) from straight adapter (8).
- (5) Remove gauge (7).

## d. Remove Fluid Pressure Regulating Valve.

- (1) Disconnect tubing (18) at connection (16). Remove tubing.
- (2) Unscrew and remove fluid pressure regulating valve (14) from straight adapter (17).

## REPAIR

Repair at this level of maintenance is by replacement of dial indicating pressure gauge (7) and fluid pressure regulating valve (14).

## NOTE

Panel parts kit is provided for complete repair of brake panel.

## ASSEMBLY

## a. Replace Fluid Pressure Regulating Valve.

- (1) Remove caps or plugs from tubing and adapters prior to connecting.
- (2) Apply teflon tape to threaded portion of straight adapter (17).
- (3) Install fluid pressure regulating valve (14) on straight adapter.
- (4) Apply teflon tape to tubing (18) connection (16). Connect tubing to fluid pressure regulating valve.

b. Replace Dial Indicating Pressure Gauge.

- (1) Remove caps or plugs from tubing and adapters prior to connecting.
- (2) Apply teflon tape to threaded portion of straight adapter (8).
- (3) Install dial indicating pressure gauge (7) on straight adapter.
- (4) Apply teflon tape to threaded portion of straight adapter (6).
- (5) Install system pressure regulating valve (5) on straight adapter.

## **TM 55-1905-223-24-18-1**

- (6) Apply teflon tape to threaded portion of tubing (18, 20).
- (7) Connect tubing (18) at connection (19).
- (8) Connect tubing (20) at connection (4).
- (9) Apply teflon tape to threaded portions of tubing (10).
- (10) Connect tubing at connections (8, 11).
- (11) Replace panel cover (1) and secure to brake panel (3) with cover latches (2)

### **REPLACEMENT**

- a. Position brake panel (3) on bracket.
- b. Secure with four machine screws (21).
- c. Remove caps or plugs from tubing.
- d. Connect tubing at connections (12, 13, and 15).
- e. Restore air pressure to brake panel and remove tags.



---

2-123. Replace/Repair Governor Actuator Assembly. (FIGURE 2-108)

---

This task covers: a. Removal, b. Repair, c. Replacement.

---

### INITIAL SETUP

#### Tools

Tool kit, general mechanic's,  
5180-00-699-5273

#### Materials/Parts

Governor actuator assembly  
P/N B202-1009  
Warning tags, Item 1, Appendix C  
Teflon tape, Item 5, Appendix C

#### Equipment Condition

Main propulsion engines and  
bowthrustrer engine secured and  
tagged "Out of Service - Do Not  
Operate." (TM 55-1905-223-10)  
Air supply secured at air  
preparation system and tagged  
"Out of Service - Do Not Operate."  
(TM 55-1905-223-10)

---

### REMOVAL

- a. Disconnect tubing (1) at connection (2). Cap or plug tubing.
- b. Disconnect rod end (4) at hex nut (5).
- c. Remove governor actuator manual over-ride (6).
- d. Remove two hex head machine bolts (7).
- e. Remove governor actuator assembly (3) from main propulsion engines and bowthrustrer engine.

### REPAIR

Repair at this level of maintenance is by replacement of governor actuator assembly (3).

### REPLACEMENT

- a. Position governor actuator assembly (3) on main propulsion engines and bowthrustrer engine.
- b. Secure with two hex head machine bolts (7).
- c. Attach governor actuator manual override (6) to rod end (4).

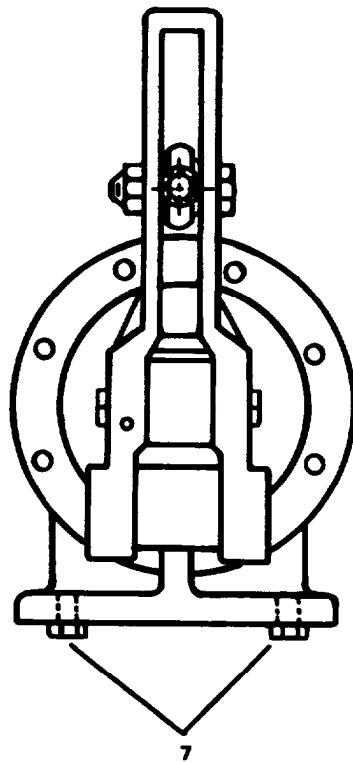
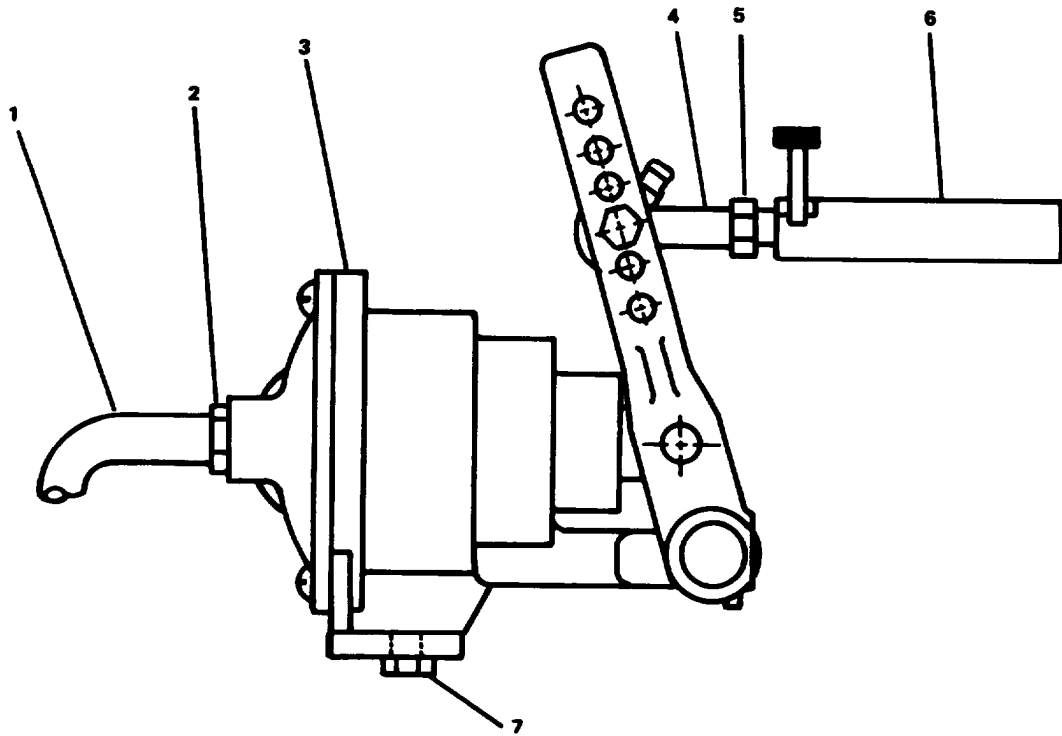


FIGURE 2-108. Governor Actuator Assembly.

- d. Secure with hex nut (5).
- e. Remove caps or plugs from tubing.
- f. Apply teflon tape to threaded portion of connection (2).
- g. Secure tubing (1) and connection (2) to governor actuator assembly (3).
- h. Restore air supply to governor actuator assembly and remove tags.
- i. Restore main propulsion engines and bowthruster engine to operational condition and remove tags.

2-124. Replace/Repair Manual Over-Ride Governor Actuator. (FIGURE 2-109)

---

This task covers: a. Disassembly, b. Repair, c. Assembly.

---

INITIAL SETUP

Tools

Tool kit, general mechanic's,  
5180-00-699-5273

Materials/Parts

Manual over-ride governor  
actuator P/N D320-4001  
Lubriplate No. 107,  
Item 6, Appendix C  
Warning tags, Item 1, Appendix C  
Petroleum base solvent,  
Item 37, Appendix C

Equipment Condition

Main propulsion engines and  
bowthruster engine secured and  
tagged "Out of Service - Do Not  
Operate." (TM 55-1905-223-10)  
Air supply secured at air  
preparation system and tagged  
"Out of Service - Do Not Operate."  
(TM 55-1905-223-10)  
Manual over-ride governor  
actuator removed from governor  
actuator, para. 2-123.

---

DISASSEMBLY

- a. Loosen lock nut (2).
- b. Unscrew knurled head screw (1).
- c. Slide shaft (3) out of sleeve (4).

REPAIR

- a. Repair at this level of maintenance is by replacement of parts that are damaged or worn.
- b. Clean all parts with petroleum base solvent, and blow dry with low pressure air.

ASSEMBLY

- a. Lubricate each part with Lubriplate No. 107.
- b. Slide shaft (3) into sleeve (4).
- c. Screw knurled head screw (1) down onto shaft (3).

- d. Secure with lock nut (2).
- e. Attach manual over-ride governor actuator to governor actuator, para. 2-123.
- f. Restore air supply to governor actuator and remove tags.
- g. Restore main propulsion engines and bowthruster engine to operational condition and remove tags.

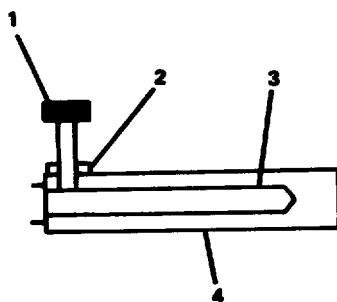


FIGURE 2-109. Manual Over-Ride Governor Actuator.

2-125. Replace/Repair Linear Directional Control Valve.

---

This task covers: a. Removal, b. Disassembly, c. Repair, d. Assembly, e. Replacement.

---

INITIAL SETUP

Tools

Tool kit, general mechanic's,  
5180-00-699-5273

Materials/Parts

Preformed packing P/N H134-66  
Preformed packing P/H H136-93  
Gasket P/N M223-006  
Preformed packing P/N H135-27  
Warning tags, Item 1, Appendix C  
Teflon tape, Item 5, Appendix C

---

Equipment Condition

Air supply to linear directional control valve secured and tagged "Out of Service - Do Not Operate" at LPA-8 (Supply to Control Air). (TM 55-1905-223-10)

**WARNING**

To avoid personal injury; slowly open tubing connection to allow buildup pressure to escape.

**NOTE**

Cap or plug tubing connections when removed to ensure no contamination enters lines.

REMOVAL (FIGURE 2-110)

- a. Disconnect tubing at connections (3, 4, 5, 6, and 7).
- b. Remove four machine bolts and self-locking nuts (2).
- c. Remove control valve (1) from bracket (8).

DISASSEMBLY (FIGURE 2-111)

- a. Remove machine screw (1), stop stem (2), lockwasher (3), and stem (4).
- b. Remove bearing assembly (5).
- c. Remove valve body (6) from housing (14).

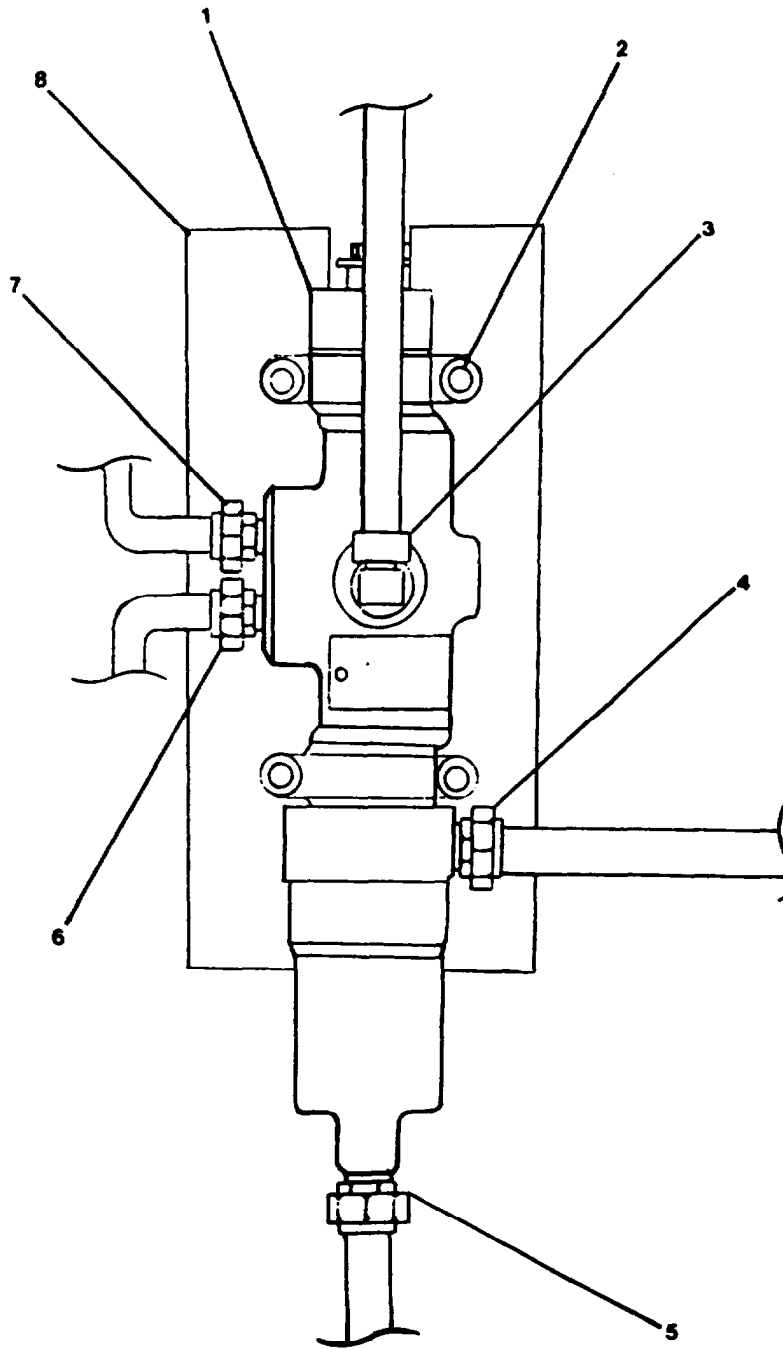


FIGURE 2-110. Linear Directional Control Valve, Removal.

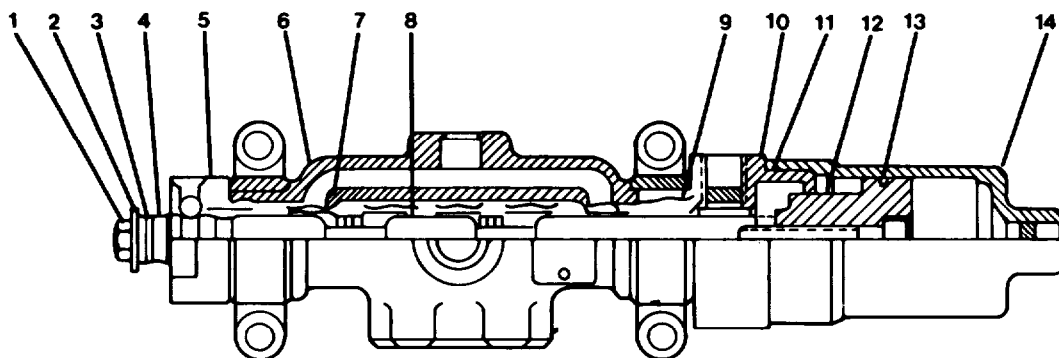


FIGURE 2-111. Linear Directional Control Valve Disassembly.

- d. Remove spacer (7) and preformed packing (8).
- e. Remove preformed packing (9) from housing (14).
- f. Remove retainer (10) and gasket (11) from piston (12).
- g. Remove preformed packing (13).

## REPAIR

Repair at this level of maintenance is by replacement of preformed packings (8, 9, and 13) and gasket (11).

## ASSEMBLY

- a. Install preformed packing (13).
- b. Install gasket (11) in piston (12). Install retainer (10).
- c. Install preformed packing (9) in housing (14).
- d. Install preformed packing (8) and spacer (7).
- e. Install valve body (6) on housing (14).
- f. Install bearing assembly (5) on valve body (6).
- g. Install stem (4), lockwasher (3), stop stem (2), and machine screw (1).



REPLACEMENT (FIGURE 2-110)

- a. Install control valve (1) on bracket (8).
- b. Secure with four machine bolts and self-locking nuts (2).
- c. Remove caps or plugs prior to connection.
- d. Apply teflon tape to threaded portion of connections.
- e. Connect tubing at connections (3, 4, 5, 6, and 7).
- f. Restore air pressure to linear directional control valve at LPA-8 (supply to control air), remove tag.

2-126. Replace/Repair Bowthrustrer/Fire Pump Valve System.

---

This task covers: a. Removal, b. Disassembly, c. Repair, d. Assembly, e. Replacement.

---

INITIAL SETUP

Tools

Tool kit, general mechanic's,  
5180-00-699-5273

Materials/Parts

Four-way valve P/N MOOO-20431  
Roller operated valve P/N M095-218-03  
Cylinder assembly P/N FWDOO-0013  
Preformed packing P/N H134-113  
Wearing ring P/N B813-119  
Preformed packing P/N H145-64  
Preformed packing P/N H136-21  
Bearing rod P/N H004-91  
Preformed packing P/N H145-26  
Preformed packing P/N H092-134  
Cylinder assembly repair kit (for  
complete repair of cylinder  
assembly) P/N B730-21003  
Warning tags, Item 1, Appendix C  
Cleaning solvent, Item 5A, Appendix C  
Pneumatic grease, Item 7, Appendix C  
Lubriplate No. 107, Item 6, Appendix C  
Wiping rags, Item 14, Appendix C

---

Equipment Condition

Auxiliary (diesel driven) fire pump  
and bowthrustrer engine secured and  
tagged. "Out of Service - Do Not  
Operate." (TM 55-1905-223-10)  
Turn OFF air supply to the bowthrustrer  
control station and vent pressure to  
atmosphere.

**WARNING**

Make sure air pressure is vented before  
removing valves or cylinders to avoid  
personal injury.

**CAUTION**

Make sure tubing is capped or plugged when  
disconnected to prevent foreign material  
from entering the system.

REMOVAL (FIGURE 2-112)a. Remove Four-Way Valve.

- (1) Disconnect tubing at (3, 4, 5, 6, and 7). Cap or plug tubing.
- (2) Remove mounting hardware (2).
- (3) Remove four-way valve (8) from mounting bracket.

b. Remove Roller Operated Valve (Fire Pump).

- (1) Disconnect tubing at (9, 11). Cap or plug tubing.
- (2) Remove mounting hardware (12).
- (3) Remove roller operated valve (10) from mounting bracket.

c. Remove Roller Operated Valve (Bowthruster).

- (1) Disconnect tubing at (13, 15). Cap or plug tubing.
- (2) Remove mounting hardware (16).
- (3) Remove roller operated valve (14) from mounting bracket.

d. Remove Cylinder Assembly (Fire Pump).

- (1) Disconnect tubing at (17, 19). Cap or plug tubing.
- (2) Remove clevis pin and mounting hardware (18, 20).
- (3) Remove cylinder assembly (21) from mounting bracket.

e. Remove Cylinder Assembly (Bowthruster).

- (1) Disconnect tubing at (22, 24). Cap or plug tubing.
- (2) Remove clevis pin and mounting hardware (23, 25).
- (3) Remove cylinder assembly (26) from mounting bracket.

DISASSEMBLY (Cylinder Assembly) (FIGURE 2-113).

- a. Cylinder assemblies removed for disassembly and repair.
- b. Remove socket head screws (15) and tie rod nuts (18).
- c. Remove clevis bracket (16) and eye bracket (20).
- d. Remove cap (14) and rod clevis (17).
- e. Remove piston rod (2).

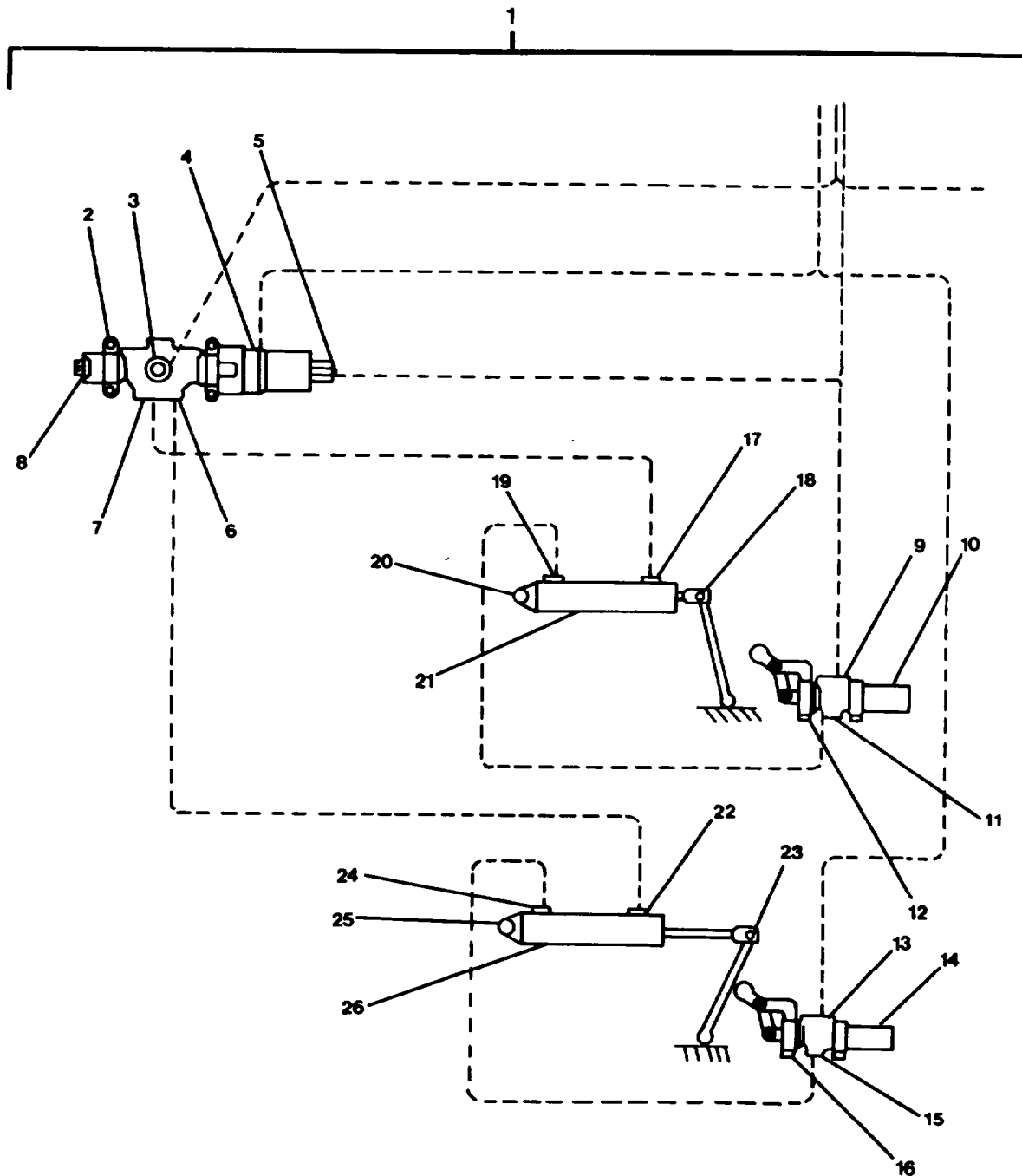


FIGURE 2-112. Bowthruster/Fire Pump Valve System.

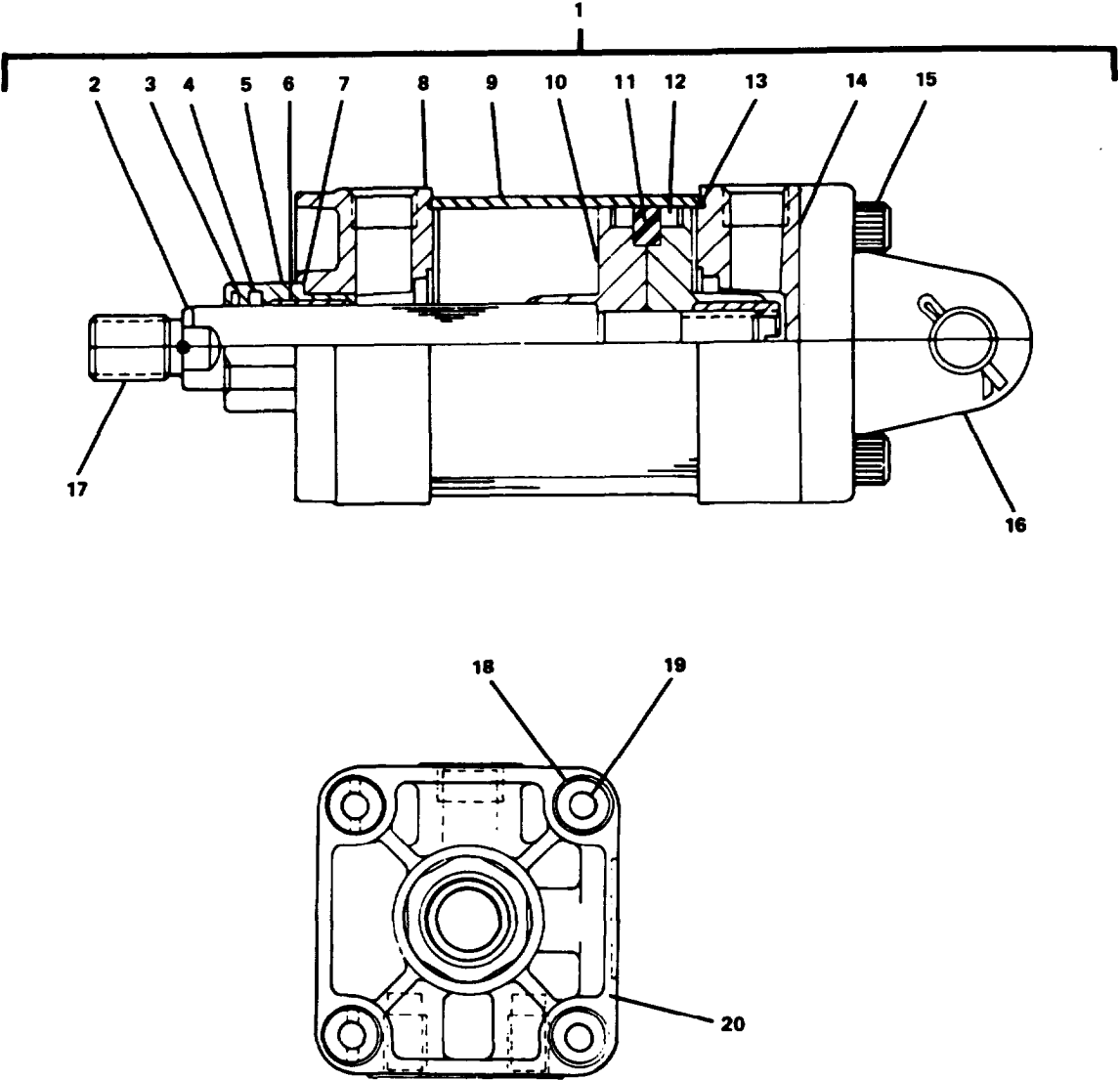


FIGURE 2-113. Cylinder Assembly.

## TM 55-1905-223-24-18-1

- f. Remove preformed packing (12, 13) from tube cylinder (9).
- g. Remove wearing ring (11).
- h. Remove cylinder head (8).
- i. Remove piston (10).
- j. Remove preformed packing (7).
- k. Remove bearing rod (6) from rod guide (5).
- l. Remove preformed packing (3, 4).

### REPAIR

- a. Repair at this level of maintenance is by replacement of four-way valve (8, FIGURE 2-112), roller operated valves (10, 14), preformed packing (3, 4, 7, 12, and 13, FIGURE 2-113), wearing ring (11), and bearing rod (6).

#### **NOTE**

Cylinder assembly repair kit is provided for complete repair of cylinder assembly.

- b. Clean all metal parts with petroleum base solvent, mineral spirits or kerosene.
- c. Wash all rubber parts with soap and water. Rinse thoroughly and blow dry with low-pressure air.
- d. Replace those parts which are worn or damaged.

### ASSEMBLY (FIGURE 2-113)

#### **CAUTION**

Avoid cutting or nicking the piston preformed packing by carefully inserting the piston rod assembly into the cylinder bore with the piston tilted at a slight angle.

#### **NOTE**

Lubricate all rubber parts with Dow Corning No. 55 pneumatic grease, and all moving parts with Lubriplate No. 107. Equivalent greases may be used.

- a. Install preformed packing (3, 4) in rod guide (5).
- b. Install bearing rod (6).
- c. Install preformed packing (7) in cylinder head (8).

- d. Install piston (10), wearing ring (11), and preformed packing (12, 13) in tube cylinder (9).
- e. Install piston rod (2).
- f. Install rod clevis (17).
- g. Line up tie rods (19) with holes in eye bracket (20) and cap (14).
- h. Secure eye bracket with tie rod nuts (18).
- i. Install cap (14) and secure with socket head screws (15).

REPLACEMENT (FIGURE 2-112)

- a. Replace Cylinder Assembly (Bowthruster).

**CAUTION**

Make sure all air lines in the system are blown free of any foreign material before replacement.

- (1) Position cylinder assembly (26) on mounting bracket and secure with mounting hardware (23, 25).
- (2) Remove caps or plugs from tubing.
- (3) Connect tubing at (22, 24).
- b. Replace Cylinder Assembly (Fire Pump).
  - (1) Position cylinder assembly (21) on mounting bracket and secure with mounting hardware (18, 20).
  - (2) Remove caps or plugs from tubing.
  - (3) Connect tubing at (17, 19).
- c. Replace Roller Operated Valve (Bowthruster).
  - (1) Position roller operated valve (14) on mounting bracket and secure with mounting hardware (16).
  - (2) Remove caps or plugs from tubing.
  - (3) Connect tubing at (13, 15).
- d. Replace Roller Operated Valve (Fire Pump).
  - (1) Position roller operated valve (10) on mounting bracket and secure with mounting hardware (12).
  - (2) Remove caps or plugs from tubing.

- (3) Connect tubing at (9, 11).
- e. Replace Four-Way Valve.
  - (1) Position four-way valve (8) on mounting bracket and secure with mounting hardware (2).
  - (2) Remove caps or plugs from tubing.
  - (3) Connect tubing at (3, 4, 5, 6, and 7).
- f. Turn ON air supply to bowthruster control station.
- g. Restore bowthruster engine and auxiliary (diesel driven) fire pump to operation and remove tags.



---

2-127. Repair Machinery Plant Monitoring and Alarm System.

---

This task covers: Repair.

---

### INITIAL SETUP

#### Tools

Tool kit, electrician's  
5180-00-391-1087

#### Materials/Parts

Warning tags, Item 1, Appendix C

#### Equipment Condition

Electrical power to machinery plant monitoring and alarm system secured and tagged, "Out of Service - Do Not Operate." at ship service switchboard (TM 55-1905-223-10)

---

### REPAIR

Repair of machinery plant monitoring and alarm system at this level is by repair of the components in the system (refer to paragraphs 2-128 through 2-141).

2-128. Repair Engine Room Panel Assembly. (FIGURE 2-114).

---

This task covers: a. Disassembly, b. Repair, c. Assembly.

---

INITIAL SETUP

Tools

Tool kit, electrician's,  
5180-00-391-1087

Equipment Condition

Power to controls system secured  
and tagged "Cut of Service - Do Not  
Operate." (TM 55-1905-223-10)

Materials/Parts

Push switch P/N 71-1022-000  
Light lens (acknowledge)  
P/N 71-1022-106  
Incandescent lamp (28 Volt)  
P/N 71-1021-000  
Light lens (power on lamp test)  
P/N 71-1023-100  
Light lens (deadman alarm)  
P/N 71-1022-107  
Push switch P/N 71-1023-000  
Light lens (scan) (P/N 71-1023-101  
Light lens (minus page) P/N 71-1023-102  
Light lens (plus page) P/N 71-1023-103  
Push switch P/N 71-1028-000  
Light lens (engineers assist)  
P/N 71-1022-108  
Push switch P/N 71-1529-000  
Light lens (start/run) P/N 71-1529-100  
Light lens (stop) P/N 71-1529-002  
Indicator light P/N 71-1026-000  
Light lens (run) P/N 71-1026-001  
Incandescent lamp P/N 71-1021-001  
Light lens (engine room)  
P/N 71-1026-002  
Light lens (bridge) P/N 71-1026-003  
Push switch P/N 71-1025-000  
Light lens (start) P/N 71-1529-001  
Light lens (stop) P/N 71-1529-002  
Warning tags, Item 1, Appendix C

---

DISASSEMBLY

- a. Grasp light lens (scan) (4) between thumb and forefinger and squeeze gently until lens pops free. Remove lens.

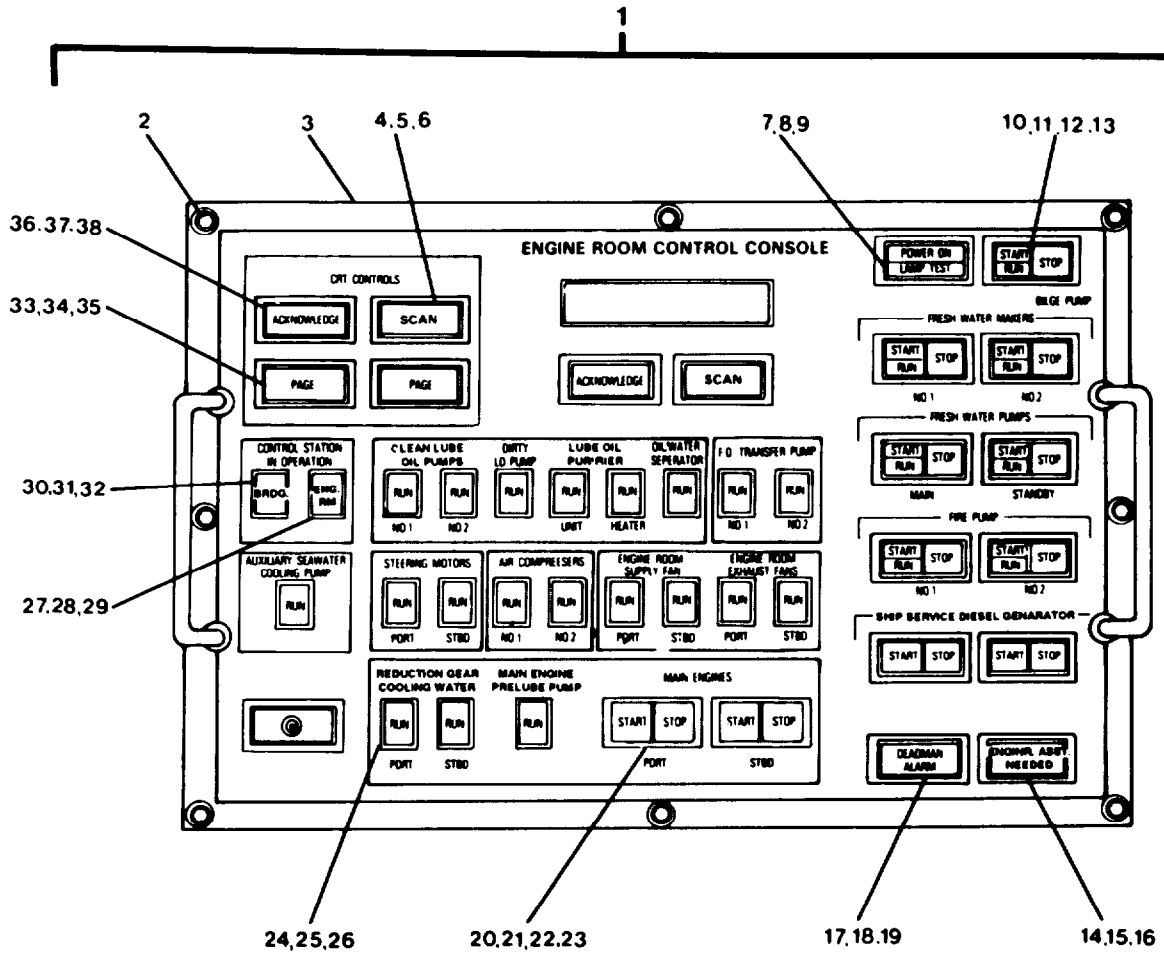


FIGURE 2-114. Panel Assembly, Engine Room.

- b. Remove incandescent lamp (5) and push switch (6).
- c. Repeat procedures a. and b. for remaining scan indicator.
- d. Grasp light lens (power on lamp test) (7) between thumb and forefinger and squeeze gently until lens pops free. Remove lens.
- e. Remove incandescent lamp (8) and push switch (9).
- f. Grasp light lens (start/run) (10) between thumb and forefinger and squeeze gently until lens pops free. Remove lens.
- g. Repeat procedure f. for light lens (stop) (11).
- h. Remove incandescent lamp (12) and push switch (13).
- i. Repeat procedures f. through h. for remaining start/run and stop indicators.
- j. Grasp light lens (engineer assist) (14) between thumb and forefinger and squeeze gently until lens pops free. Remove lens.
- k. Remove incandescent lamp (15) and push switch (16).
- l. Grasp light lens (deadman alarm) (17) between thumb and forefinger and squeeze gently until lens pops free. Remove lens.
- m. Remove incandescent lamp (18) and push switch (19).
- n. Grasp light lens (start) (20) between thumb and forefinger and squeeze gently until lens pops free. Remove lens.
- o. Repeat procedure n. for light lens (stop) (21).
- p. Remove incandescent lamp (22) and indicator lights (23).
- q. Repeat procedures n. through p. for remaining start and stop indicators.
- r. Grasp light lens (run) (24) between thumb and forefinger and squeeze gently until lens pops free. Remove lens.
- s. Remove incandescent lamp (25) and indicator light (26).
- t. Repeat procedures r. and s. for remaining run indicators.
- u. Grasp light lens (engine room) (27) between thumb and forefinger and squeeze gently until lens pops free. Remove lens.
- v. Remove incandescent lamp (28) and indicator light (29).
- w. Grasp light lens (bridge) (30) between thumb and forefinger and squeeze gently until lens pops free. Remove lens.
- x. Remove incandescent lamp (31) and push switch (32).

- y. Grasp light lens (plus page) (33) between thumb and forefinger and squeeze gently until lens pops free. Remove lens.
- z. Remove incandescent lamp (34) and push switch (35).
- aa. Repeat procedures y. and z. for (minus page) indicator.
- ab. Grasp light lens (acknowledge) (36) between thumb and forefinger and squeeze gently until lens pops free. Remove lens.
- ac. Remove incandescent lamp (37) and push switch (38).
- ad. Repeat procedures ab. and ac. for remaining acknowledge indicator.

### REPAIR

Repair at this level of maintenance is by replacement of light lenses (4, 7, 10, 11, 14, 17, 20, 21, 24, 27, 30, 33, and 36), incandescent lamps (5, 8, 12, 15, 18, 22, 25, 28, 31, 34, and 37), push switches (6, 9, 13, 16, 19, 32, 35, and 38), and indicator lights (23, 26, and 29).

### ASSEMBLY

- a. Install push switch (38) and incandescent lamp (37).
- b. Grasp light lens (acknowledge) (36) between thumb and forefinger, insert in slot and squeeze gently until lens is seated.
- c. Repeat procedures a. and b. for remaining acknowledge indicator.
- d. Install push switch (35) and incandescent lamp (34).
- e. Grasp light lens (plus page) (33) between thumb and forefinger, insert in slot and squeeze gently until lens is seated.
- f. Repeat procedures d. and e. for minus page indicator.
- g. Install push switch (32) and incandescent lamp (31).
- h. Grasp light lens (bridge) (30) between thumb and forefinger, insert in slot and squeeze gently until lens is seated.
- i. Install indicator light (29) and incandescent lamp (28).
- j. Grasp light lens engine room (27) between thumb and forefinger, insert in slot and squeeze gently until lens is seated.
- k. Install indicator light (26) and incandescent lamp (25).
- l. Grasp light lens (run) (24) between thumb and forefinger, insert in slot and squeeze gently until lens is seated.

- m. Repeat procedures k. and 1. for remaining run indicators.
- n. Install indicator light (23) and incandescent lamp (22).
- o. Grasp light lens (stop) (21) between thumb and forefinger, insert in slot and squeeze gently until lens is seated.
- p. Repeat procedure o. for light lenses (start) (20) and remaining light lenses (stop).
- q. Install push switch (19) and incandescent lamp (18).
- r. Grasp light lens (deadman alarm) (17) between thumb and forefinger, insert a slot and squeeze gently until lens is seated.
- s. Install push switch (16) and incandescent lamp (15).
- t. Grasp light lens (engineer assist) (14) between thumb and forefinger, insert in slot and squeeze gently until lens is seated.
- u. Install push switch (13) and incandescent lamp (12).
- v. Grasp light lens (stop) (11) between thumb and forefinger, insert in slot and squeeze gently until lens is seated.
- w. Repeat procedure v. for light lens (start/run) (10) and remaining light lenses (stop).
- x. Install push switch (9) and incandescent lamp (8).
- y. Grasp light lens (power on lamp test) (7) between thumb and forefinger, insert in slot and squeeze gently until lens is seated.
- z. Install push switch (6) and incandescent lamp (5).
- aa. Grasp light lens (scan) (4) between thumb and forefinger, insert in slot and squeeze gently until lens is seated.
- ab. Contact direct support maintenance to install panel assembly.

---

2-129. Repair Engine Room Multi-Remote Module. (FIGURE 2-115)

---

This task covers: a. Removal, b. Repair, c. Replacement.

---

### INITIAL SETUP

#### Tools

Tool kit, electrician's,  
5180-00-391-1087

#### Equipment Condition

Electrical power to monitoring and  
alarm system secured and tagged  
"Out of Service - Do Not Operate."  
(TM 55-1905-223-10)

#### Materials/Parts

Digital display indicator (2)  
P/N 61-4250-000  
Liquid level switch P/N 61-1700-002  
Liquid level switch P/N 61-1700-003  
Warning tag, Item 1, Appendix C

---

### REMOVAL

- a. Disconnect electrical cables K-C056 (1) and K-C057 (4) from liquid level switches (2, 3) and cables K-C060 (5) and K-C061 (7) from digital indicators (6, 8).
- b. Remove attaching hardware and liquid level switches (2,3).
- c. Remove attaching hardware and digital indicators (6,8).

### REPAIR

Repair at this level of maintenance is by replacement of liquid level switches (2, 3) and digital indicators (6, 8).

### REPLACEMENT

- a. Install digital indicators (6, 8). Secure with attaching hardware.
- b. Install liquid level switches (2, 3). Secure with attaching hardware.
- c. Connect electrical cables K-CO56 (1), K-CO57 (4), K-CO60 (5) and K-CO61 (7).
- d. Remove tag and turn on electrical power.

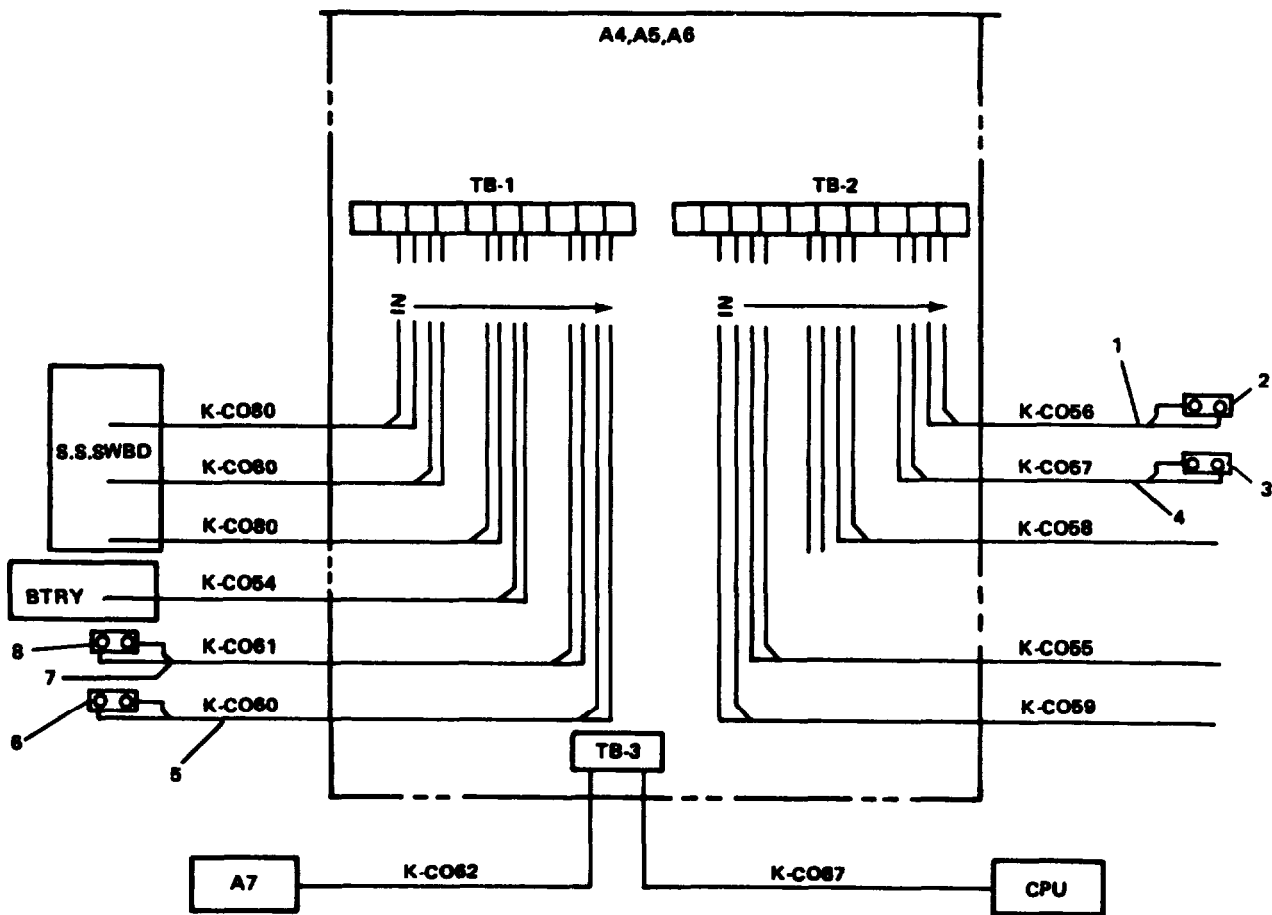


FIGURE 2-115. Engine Room Multi-Remote Module.



---

2-130. Repair Port Engine Remote Module. (FIGURE 2-116)

---

This task covers: a. Removal, b. Repair, c. Replacement.

---

### INITIAL SETUP

#### Tools

Tool kit, electrician's,  
5180-00-391-1087

#### Equipment Condition

Electrical power to controls system  
secured and tagged "Out of Service  
Do Not Operate".  
(TM 55-1905-223-10)

#### Materials/Parts

Solid state switch P/N 91-2003-0000  
Solid state switch P/N 86435  
Pressure switch P/N 1836-A2J  
Pressure switch P/N PIS-3030  
Liquid level switch P/N 61-17001-001  
Liquid level switch (2)  
P/N 61-2050-000  
Warning tags, Item 1, Appendix C

---

### REMOVAL

#### NOTE

Prior to performing maintenance at the unit level, intermediate direct support maintenance must first remove the electrical power cables.

- a. Loosen captive screws (1) and open cover (2) on enclosure (3, Sheet 1).
- b. Tag and disconnect electrical leads and remove solid state switch (4).
- c. Remove liquid level switch (5, Sheet 2).
- d. Remove solid state switch (6).
- e. Remove liquid level switch (7).
- f. Remove pressure switch (8).
- g. Remove liquid level switch (9).
- h. Remove pressure switch (10).

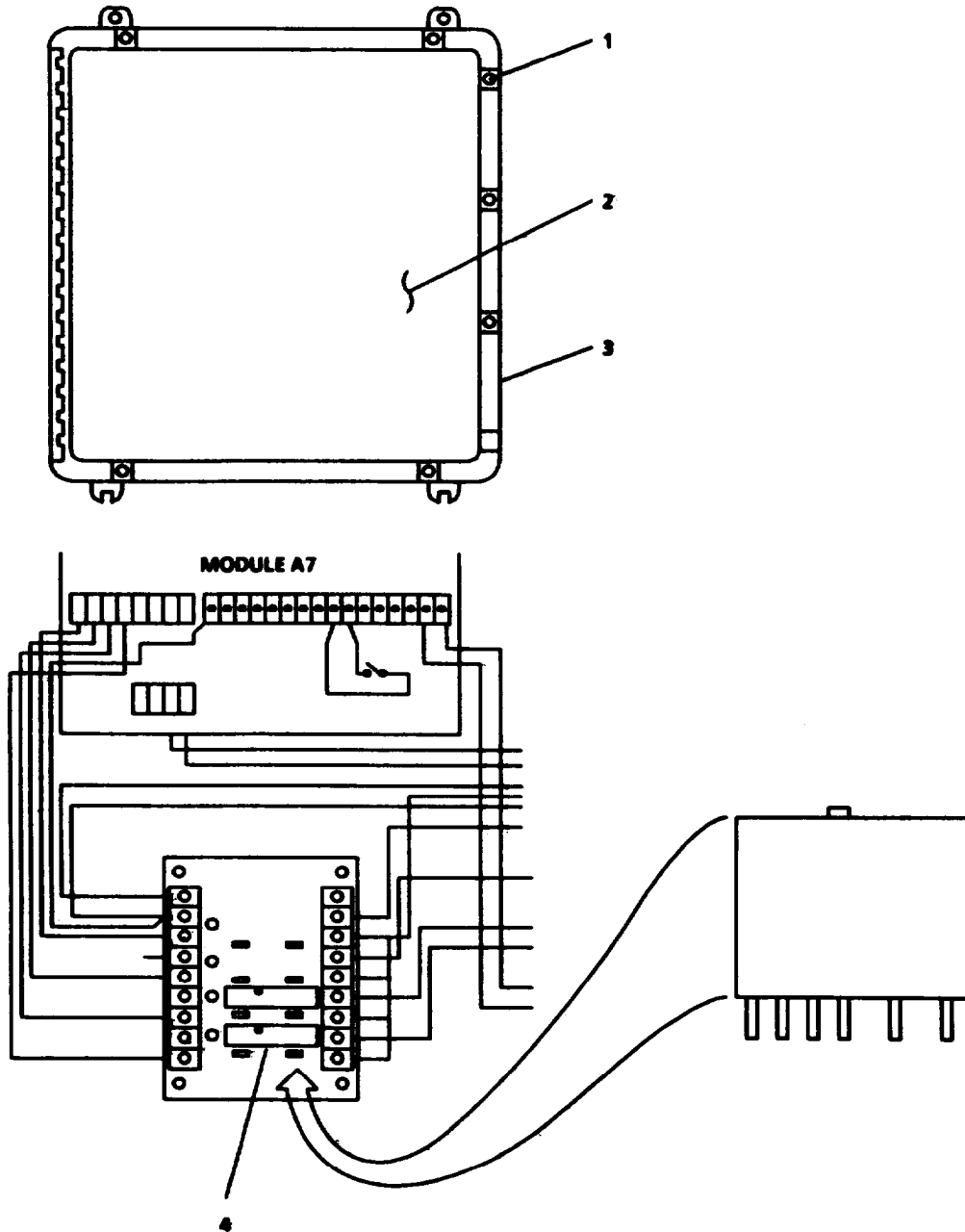


FIGURE 2-116. Port Engine Remote Module (Sheet 1 of 2).

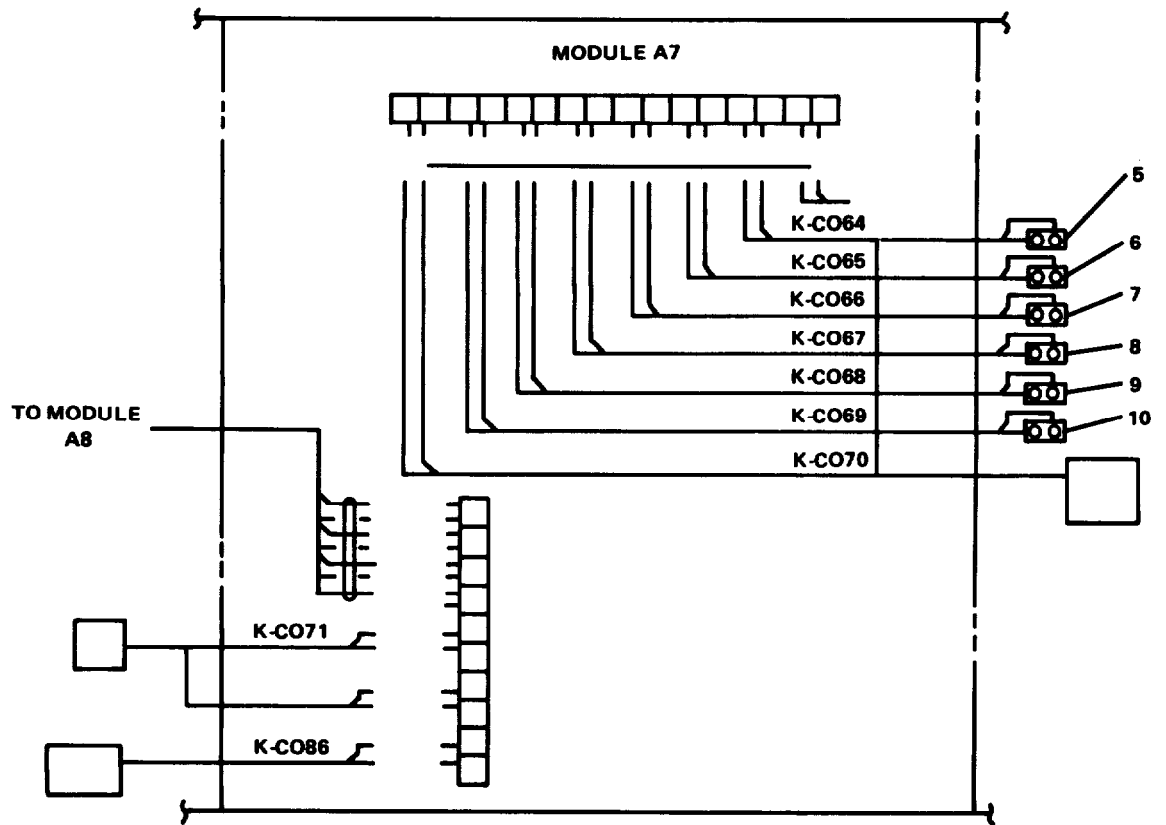


FIGURE 2-116. Port Engine Remote Module (Sheet 2 of 2).

**REPAIR**

Repair at this level of maintenance is by replacement of solid state switches (4, Sheet 1; 6, Sheet 2), pressure switches (8, 10), and liquid level switches (5, 7, 9).

**REPLACEMENT**

- a. Install pressure switch (10).
- b. Install liquid level switch (9).
- c. Install pressure switch (8).
- d. Install liquid level switch (7).
- e. Install solid state switch (6).
- f. Install liquid level switch (5).
- g. Install solid state switch (4, Sheet 1) and remove tags and connect electrical leads.
- h. Close cover (2) on enclosure (3) and tighten captive screws (1).
- i. Remove tag and turn on electrical power to port engine remote module.

---

**2-131. Repair Annunciator (Engineer's Quarters and Galley). (FIGURE 2-117)**

---

This task covers: a. Disassembly, b. Repair, c. Assembly.

---

**INITIAL SETUP****Tools**

Tool kit, electrician's,  
5180-00-391-1087

**Equipment Condition**

Electrical power OFF and tagged  
"Out of Service - Do Not Operate"  
at ship service switchboard.  
(TM 55-1905-223-10)

**Materials/Parts**

Push switch P/N 1022-000 (2)  
Light lens P/N 1022-108 (2)  
Incandescent lamp (28V)  
P/N 1021-000 (2)  
Audible alarm P/N 1000-003 (2)  
Warning tags, Item 1, Appendix C

---

**DISASSEMBLY**

- a. Loosen screws (2) to release latches (3).
- b. Swing door (1) to the left to gain access to interior.
- c. Tag and remove electrical wires (4) at screw post (5).
- d. Reach around outside of door (1) and unscrew audible alarm (6).
- e. Tag and remove electrical wires (9) from terminal board (8).
- f. Remove screws (7) and remove push switch, lens, and lamp (10).

**REPAIR**

Repair at this level of maintenance is by replace of push switches, lenses and lamps (10), and audible alarm (8).

**ASSEMBLY**

- a. Check for corrosion and clean around screw posts and connections before installing new components.
- b. Install push switch, lens, and lamp assembly (10) in door (1).
- c. Secure with two screws (7).

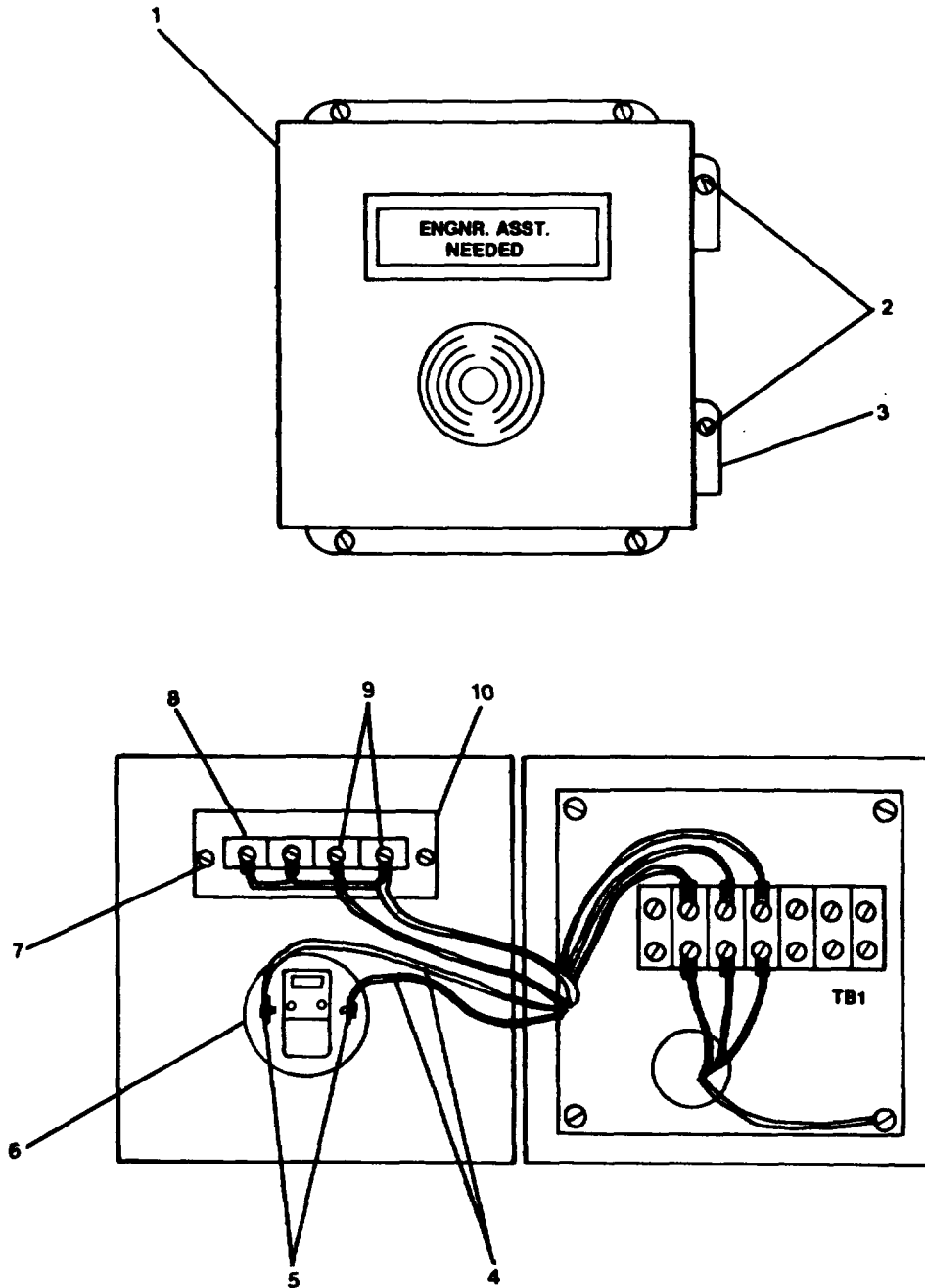


FIGURE 2-117. Annunciator (Engineer's Quarters and Galley)

- d. Connect electrical wires (9) to terminal board (8) and remove tags.
- e. Screw audible alarm (6) into door (1).
- f. Connect electrical wires (4) to screw posts (5) and remove tags.
- g. Swing door to the right and secure with latches (3) and screws (2).
- h. Restore power to the annunciator and remove "Out of Service - Do Not Operate" tag.

2-132. Replace/Repair Interface Unit Assembly. (FIGURE 2-118)

---

This task covers: a. Removal, b. Repair, c. Replacement.

---

### INITIAL SETUP

#### Tools

Tool kit, electrician's,  
5180-00-391-1087

#### Equipment Condition

Electrical power to controls system  
secured and tagged "Out of Service -  
Do Not Operate" at ship service  
switchboard. (TM 55-1905-223-10)

#### Materials/Parts

Interface unit assembly  
P/N 02-09000-000  
Electromagnetic relay (2)  
P/N 91-1000-000  
Warning tag, Item 1, Appendix C

---

### REMOVAL

- a. Loosen captive screws (1) and open cover (2).
- b. Remove relay retainer (3).
- c. Remove electromagnetic relay (4).

### REPAIR

Repair at this level of maintenance is by replacement of electromagnetic relay (4).

### REPLACEMENT

- a. Install electromagnetic relay (4).
- b. Install relay retainer (3).
- c. Close cover (2) and tighten captive screws (1).



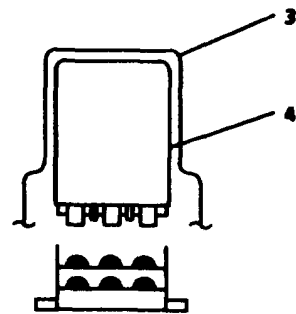
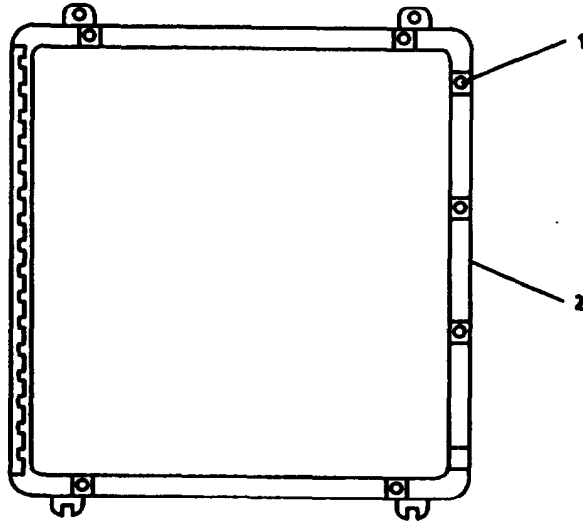


FIGURE 2-118. Interface Unit.

2-133. Repair Starboard Engine Remote Module. (FIGURE 2-119)

---

This task covers: a. Disassembly, b. Repair, c. Assembly.

---

INITIAL SETUP

Tools

Tool kit, electrician's,  
5180-00-391-1087

Materials/Parts

Pressure switch P/N 836-A2J  
Pressure switch P/N P1S-3030  
Warning tags, Item 1, Appendix C  
Teflon tape, Item 5, Appendix C  
Anti-seize compound,  
Item 15, Appendix C

Equipment Condition

Electrical power to controls system  
secured and tagged "Out of Service -  
Do Not Operate" at ship service  
switchboard. (TM 55-1905-223-10)  
Starboard engine shut down and  
tagged "Out of Service - Do Not  
Operate" at ship service switchboard.  
(TM 55-1905-223-10)

---

**NOTE**

Prior to performing maintenance at the unit level, intermediate direct support maintenance must first remove the electrical power cables.

DISASSEMBLY

- a. Tag and disconnect cables from switches (1 through 7).
- b. Remove liquid switch (1).
- c. Remove clamp assembly (2) and liquid level switch (3).
- d. Remove liquid level switch (4).
- e. Remove pressure switch (5).
- f. Remove pressure switch (6).
- g. Remove liquid level switch (7).

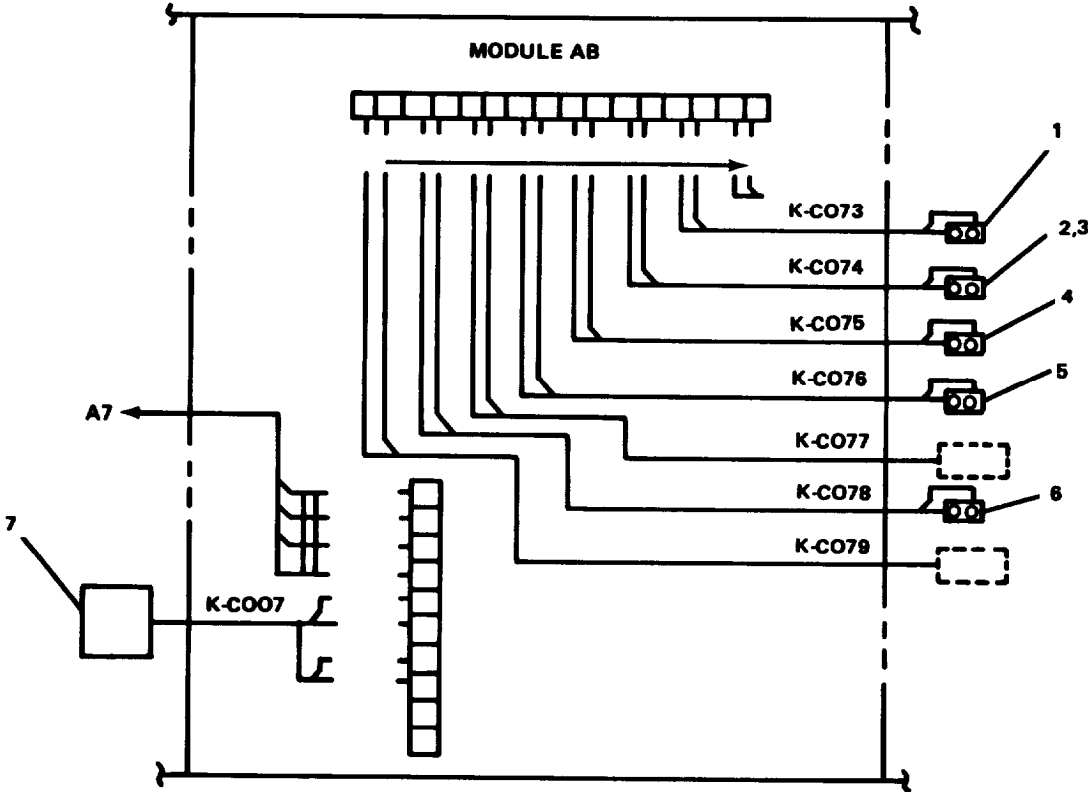


FIGURE 2-119. Remote Module, Starboard Engine.

**REPAIR**

Repair at this level of maintenance is by replacement of switches.

**ASSEMBLY**

- a. Install liquid level switch (7).
- b. Install pressure switch (6).
- c. Install pressure switch (5).
- d. Install liquid level switch (4).
- e. Install liquid level switch (3) and clamp assembly (2).
- f. Install liquid level switch (1).
- g. Remove tags and connect electrical leads at switches.

---

2-134. Replace/Repair Interface Unit Assembly. (FIGURE 2-120)

---

This task covers: a. Removal, b. Repair, c. Replacement.

---

### INITIAL SETUP

#### Tools

Tool kit, electrician's,  
5180-00-391-1087

#### Equipment Condition

Electrical power to controls system secured and tagged "Out of Service - Do Not Operate" at ship service switchboard. (TM 55-1905-223-10)

#### Materials/Parts

Electromagnetic relay  
P/N 91-1000-000  
Electromagnetic relay  
P/N 91-1011-000  
Warning tag, Item 1, Appendix C

---

### REMOVAL

- a. Loosen captive screws (1) and open cover (2) on enclosure (3).
- b. Remove relay retainers (4, 5).
- c. Remove electromagnetic relays (6, 7).

### REPAIR

Repair at this level of maintenance is by replacement of electromagnetic relays (6, 7).

### REPLACEMENT

- a. Install electromagnetic relays (6, 7).
- b. Install relay retainers (4, 5).
- c. Close cover (2) on enclosure (3) and tighten captive screw (1).
- d. Remove tag and turn on electrical power to interface unit assembly.

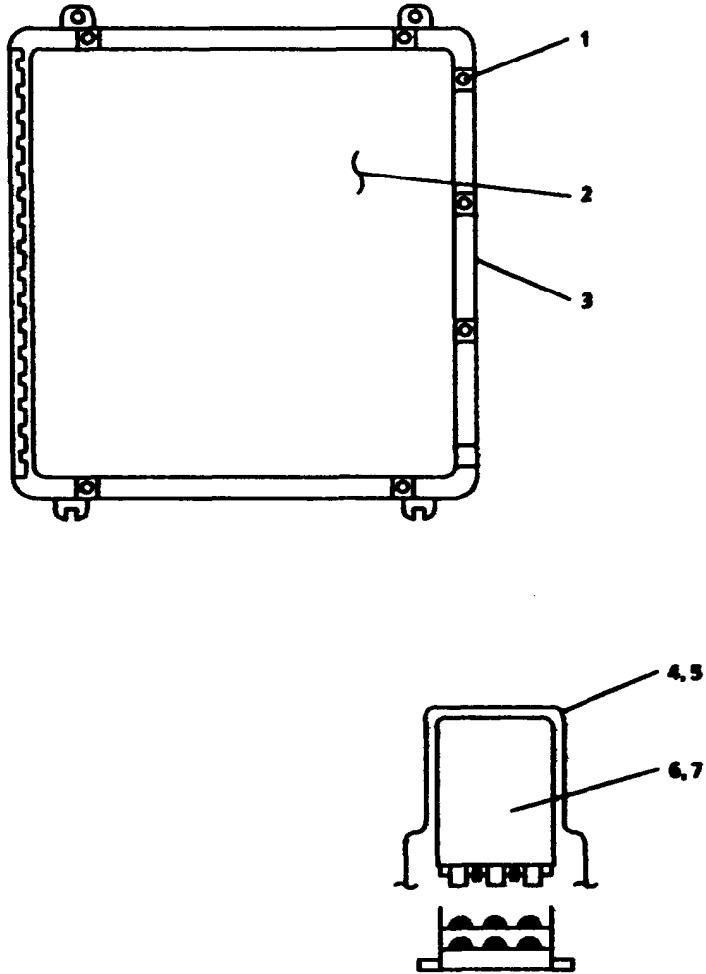


FIGURE 2-120. Interface Unit Assembly.

---

2-135. Repair Bridge Panel Assembly. (FIGURE 2-121).

---

This task covers: a. Disassembly, b. Repair, c. Assembly.

---

### INITIAL SETUP

#### Tools

Tool kit, electrician's,  
5180-00-391-1087

#### Equipment Condition

Power to controls system secured  
and tagged "Out of Service - Do Not  
Operate." (TM 55-1905-223-10)

#### Materials/Parts

Push switch P/N 71-1022-000  
Light lens (acknowledge)  
P/N 71-1022-106  
Incandescent lamp (28 Volt)  
P/N 71-1021-000  
Light lens (power on lamp test)  
P/N 71-1022-100  
Light lens (deadman alarm)  
P/N 71-1022-107  
Push switch P/N 71-1028-000  
Light lens (scan) (P/N 71-1022-101  
Light lens (minus page) P/N 71-1022-102  
Light lens (plus page) P/N 71-1022-103  
Light lens (dimmer)  
P/N 71-1022-108  
Push switch P/N 71-1529-000  
Light lens (stop) P/N 71-1022-105  
Indicator light P/N 71-1026-000  
Light lens (run) P/N 71-1026-001  
Light lens (engine room)  
P/N 71-1026-002  
Light lens (bridge) P/N 71-1026-003  
Light lens (start) P/N 71-1529-001  
Light lens (stop) P/N 71-1529-002  
Audible alarm (buzzer) P/N 71-1021-001  
Warning tags, Item 1, Appendix C

---

### DISASSEMBLY

- a. Grasp light lens (1, 4, 8, 11, 14, 16, 18, 21, 24, 27, 30, 33, 36) between thumb and forefinger. Squeeze gently until lens pops free. Remove lens.
- b. Remove incandescent lamps (2, 5, 9, 12, 15, 17, 19, 22, 25, 28, 31, 34, 37).
- c. Remove push switches (3, 6, 10, 13, 20, 23, 26, 29, 32, 35, 38)

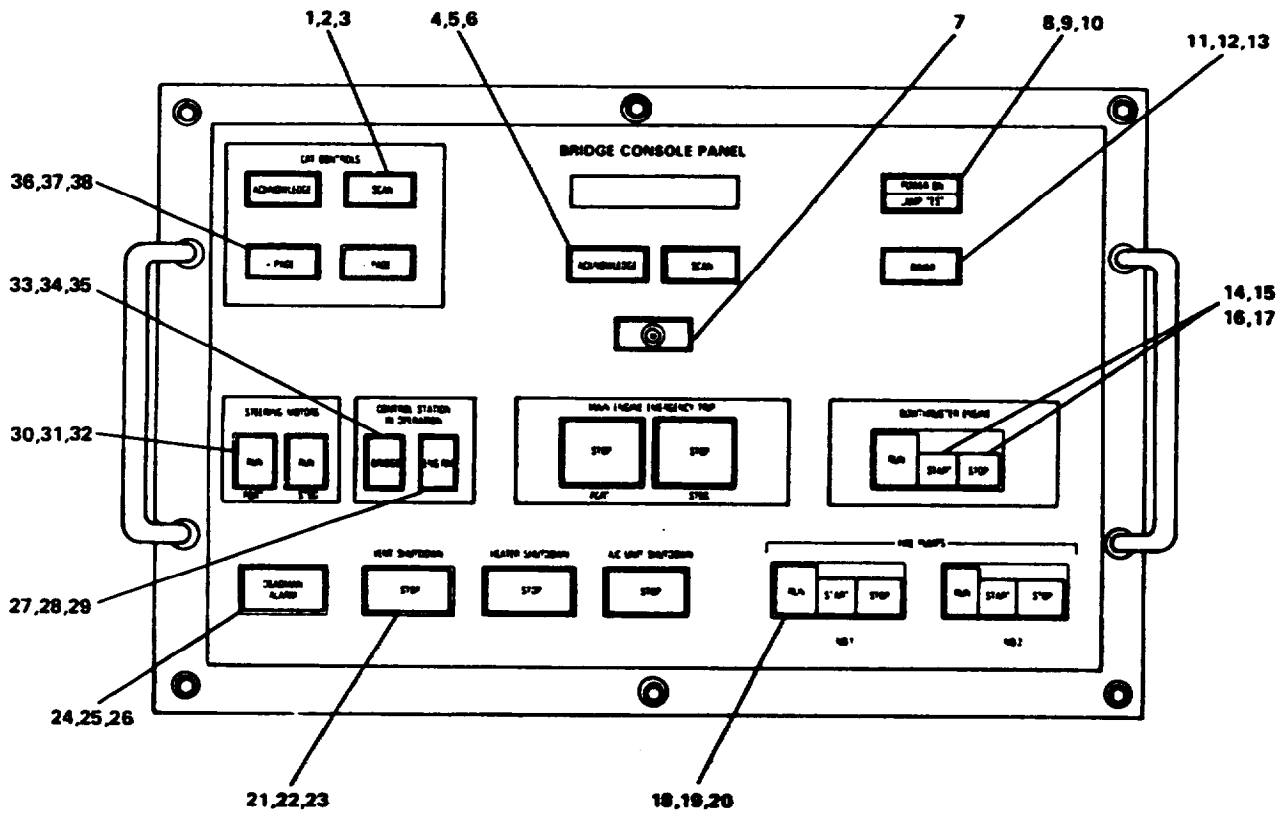


FIGURE 2-121. Bridge Panel.



- d. Remove audible alarm (7).

### **REPAIR**

Repair is by replacement of light lenses, push switches, incandescent lamps, indicator lights, and audible alarm.

### **ASSEMBLY**

- a. Install audible alarm (7).
- b. Install push switches (3, 6, 10, 13, 20, 23, 26, 29, 32, 35, 38).
- c. Install incandescent lamps (2, 5, 9, 12, 15, 17, 19, 22, 25, 28, 31, 34, 37).
- d. Grasp light lens (1, 4, 8, 11, 14, 16, 18, 21, 24, 27, 30, 33, 36) between thumb and forefinger. Insert light lens in slot. Squeeze gently until lens is seated.

2-136. Repair Central Processing Unit. (FIGURE 2-122)

---

This task covers: a. Disassembly, b. Repair, c. Assembly.

---

### INITIAL SETUP

#### Tools

Tool kit, electrician's,  
5180-00-391-1087

#### Materials/Parts

Cartridge fuse (2)  
P/N 68-00009-003  
Electromagnetic relay (2)  
P/N 51-0000-9-003  
Warning tags, Item 1, Appendix C

#### Equipment Condition

Electrical power to controls system  
secured and tagged "Out of  
Service - Do Not Operate" at ship  
service switchboard,  
(TM 55-1905-223-10)

---

### DISASSEMBLY

- a. Unscrew two retaining screws (2) and swing door (3) of enclosure (1) to the left.
- b. Unplug electromagnetic relays (4, 6) from terminal board (5).
- c. Remove fuses (9, 10) from fuse caps 7, 8.

### REPAIR

Repair at this level of maintenance is by replacement of fuses (9, 10) and magnetic relays (4, 6).

### ASSEMBLY

- a. Install fuses (9, 10) in end of fuse caps (7, 8).
- b. Insert into fuse holes, push inward and turn 1/4 turn clockwise.
- c. Plug electromagnetic relays (4, 6) into terminal board (5).
- d. Swing door (3) to the right, secure to enclosure (1) with two retaining screws (2).
- e. Restore power to central processing unit and remove tags.

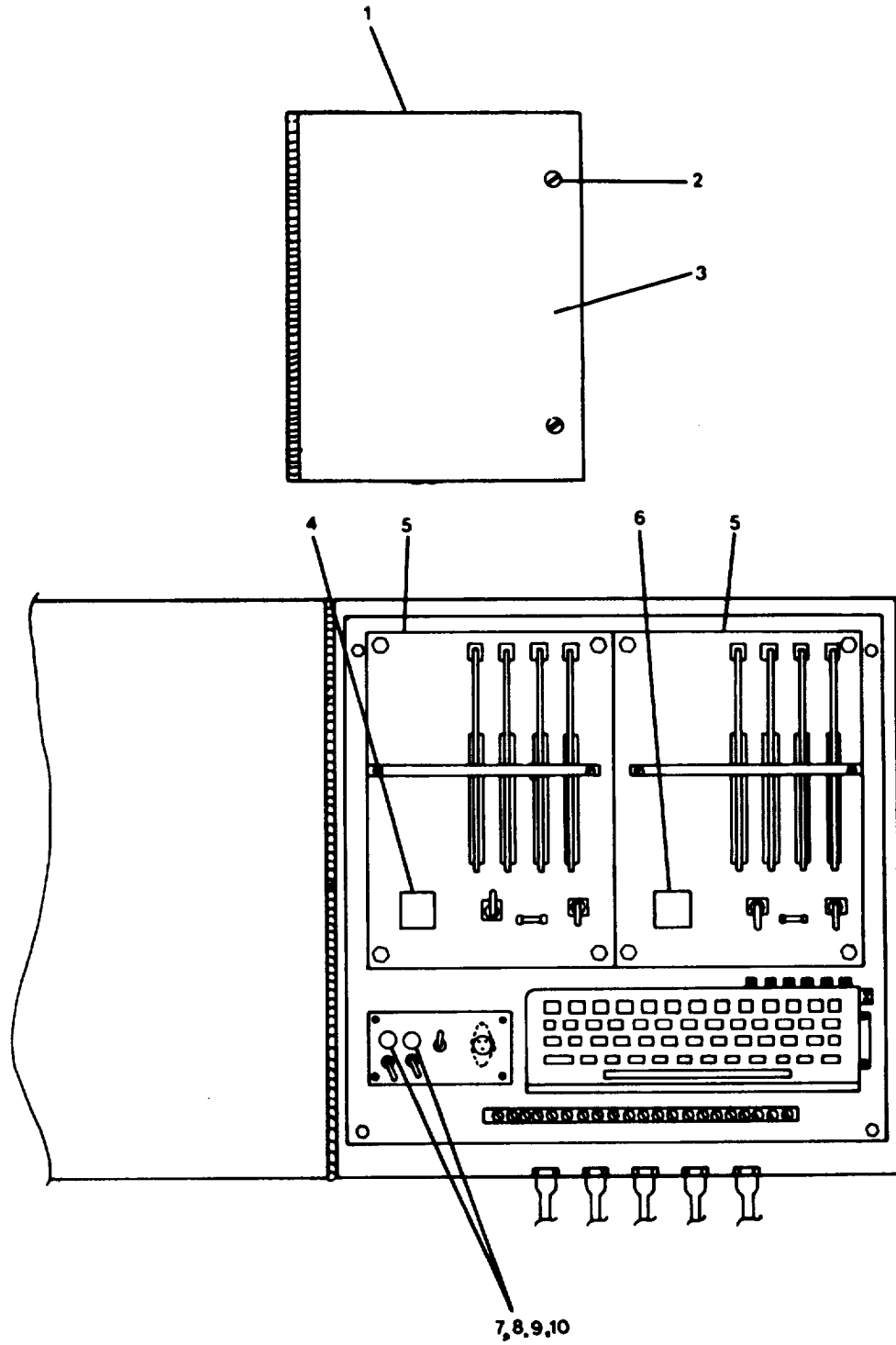


FIGURE 2-122. Central Processing Unit.

2-137. Repair Analog Remote Module Assembly. (FIGURE 2-123)

---

This task covers: a. Disassembly, b. Repair, c. Assembly.

---

INITIAL SETUP

Tools

Tool kit, electrician's,  
5180-00-391-1087

Materials/Parts

Fuses P/N 68-00G09-001  
Warning tag, Item 1, Appendix

Equipment Condition

Electrical power to machinery plant monitoring and alarm system secured and tagged "Out of Service - Do Not Operate" at ship service switchboard. (TM 55-1905-223-10).

---

DISASSEMBLY

- a. Unscrew two captive screws (1) securing door (2). Swing door to the left to open.
- b. Remove fuse (3) from fuse holder in printed circuit board B1.
- c. Remove fuse (4) from fuse holder in printed circuit board B2.
- d. Remove fuse (5) from fuse holder in printed circuit board B3.

REPAIR

Repair at this level of maintenance is by replacement of fuses (3).

**CAUTION**

Make sure replacement fuses are of the same size and rating as ones removed.

ASSEMBLY

- a. Install fuse (5) in fuse holder of printed circuit board B3.
- b. Install fuse (4) in fuse holder of printed circuit board B2.
- c. Install fuse (3) in fuse holder of printed circuit board B1.
- d. Close door (2) and secure with two captive screws (1).

- e. Restore power to analog remote module assembly and remove tag.

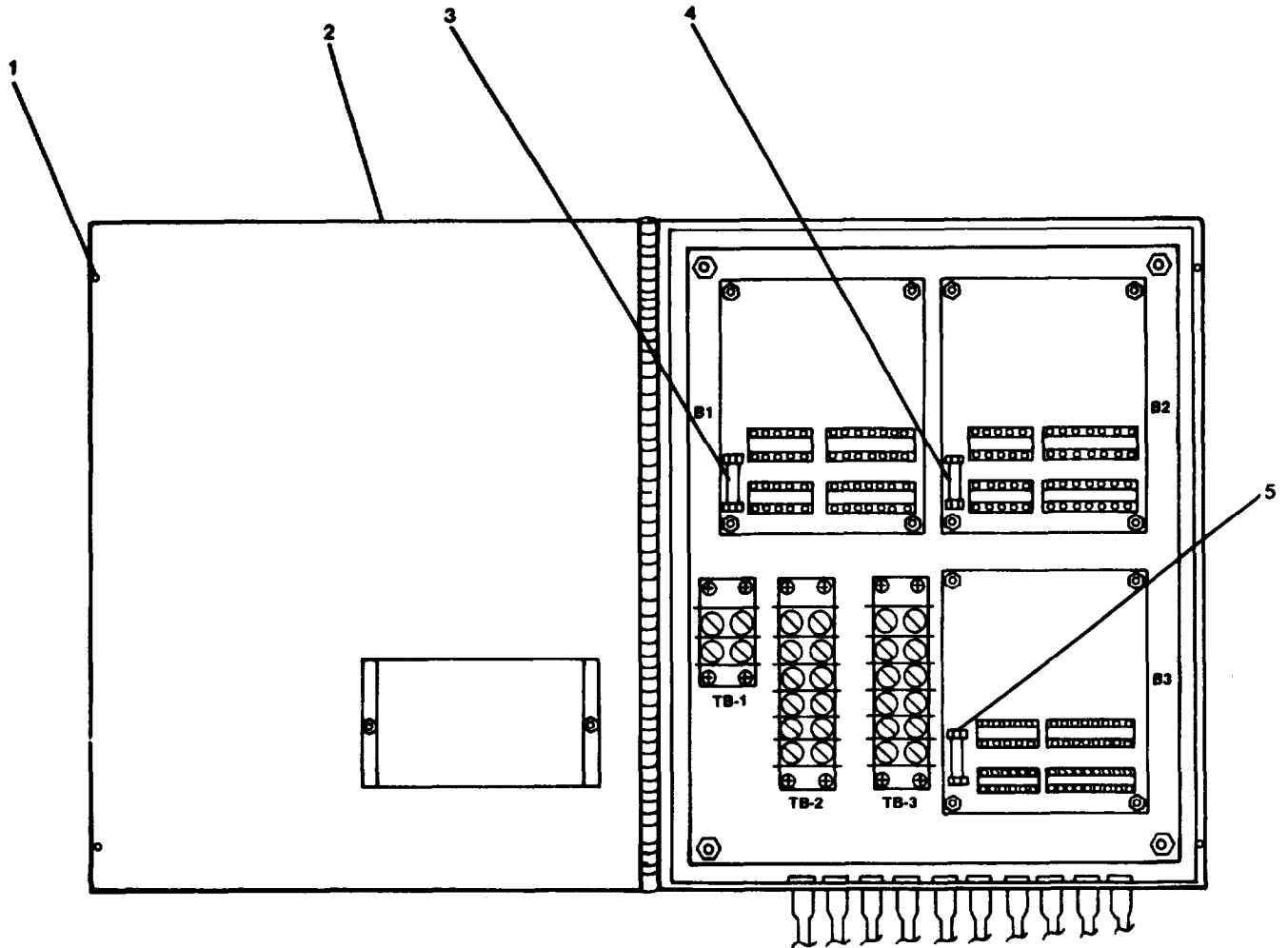


FIGURE 2-123. Analog Remote Module Assembly (Repair).

2-138. Repair Generators Remote Module. (FIGURE 2-124)

---

This task covers: a. Disassembly, b. Repair, c. Assembly.

---

### INITIAL SETUP

#### Tools

Tool kit, electrician's,  
5180-00-391-1087

#### Equipment Condition

Electrical power to controls system  
secured and tagged "Out of Service -  
Do Not Operate" at ship service  
switchboard (TM 55-1905-223-10).

#### Materials/Parts

Liquid level switch (2)  
P/N 61-2050-000

Liquid level switch P/N 61-1700-003  
Warning tags, Item 1, Appendix C

---

### DISASSEMBLY

#### NOTE

Prior to performing maintenance at the unit level,  
intermediate direct support maintenance must first remove the  
electrical power cables.

- a. Tag and disconnect electrical lead at liquid level switches (1, 2 and 3).
- b. Remove liquid level switches (1, 2 and 3).

### REPAIR

Repair at this level of maintenance is by the replacement of liquid level  
switches (1, 2, and 3).

### ASSEMBLY

- a. Install liquid level switches (1, 2, and 3).
- b. Remove tags and connect electrical leads.

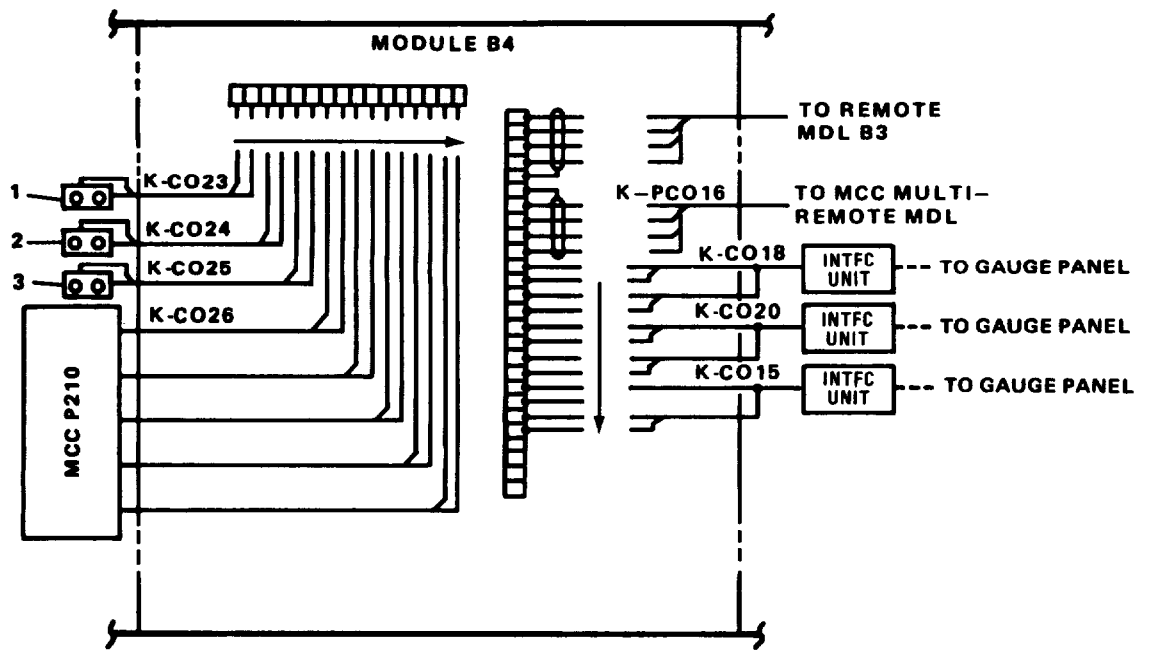


FIGURE 2-124. Generators Remote Module.

2-139. Repair Interface Unit Assembly. (FIGURE 2-125)

---

This task covers: a. Disassembly, b. Repair, c. Assembly.

---

### INITIAL SETUP

#### Tools

Tool kit, electrician's,  
5180-00-391-1087

#### Materials/Parts

Electromagnetic relay  
P/N 91-1000-000  
Electromagnetic relay  
P/N 91-1011-000  
Warning tags, Item 1, Appendix C

---

#### Equipment Condition

Electrical power to controls system  
secured and tagged "Out of Service -  
Do Not Operate" at ship service  
switchboard (TM 55-1905-223-10).

### DISASSEMBLY

- a. Loosen captive screws (1) and open cover (2) on enclosure (3).
- b. Remove relay retainers (4, 5).
- c. Remove electromagnetic relays (6, 7).

### REPAIR

Repair at this level of maintenance is by replacement of electromagnetic relays (6, 7).

### ASSEMBLY

- a. Install electromagnetic relays (6, 7).
- b. Install relay retainers (4, 5).
- c. Close cover (2) on enclosure (3) and tighten captive screw (1).
- d. Remove tag and turn on electrical power to interface unit assembly.



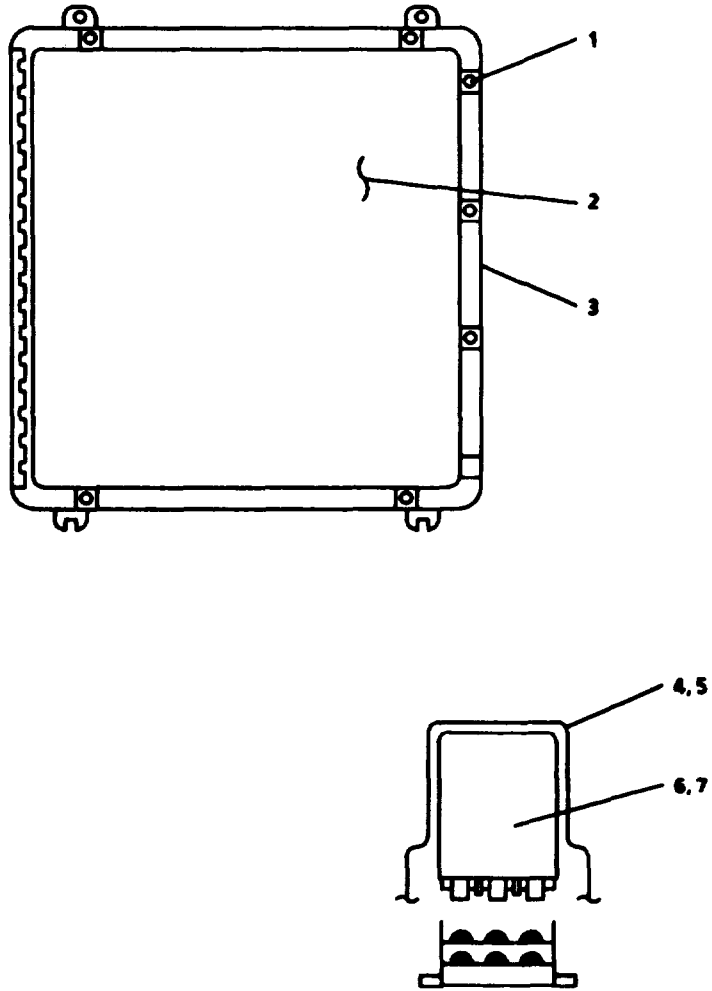


FIGURE 2-125. Interface Unit Assembly.

2-140. Repair Interface Unit Assembly. (FIGURE 2-126)

---

This task covers: a. Disassembly, b. Repair, c. Assembly.

---

### INITIAL SETUP

#### Tools

Tool kit, electrician's,  
5180-00-391-1087

#### Materials/Parts

Electromagnetic relay  
P/N 91-1000-000  
Warning tags, Item 1, Appendix C

#### Equipment Condition

Electrical power to controls system  
secured and tagged "Out of Service  
Do Not Operate" at ship service  
switchboard (TM 55-1905-223-10).

---

### DISASSEMBLY

- a. Loosen captive screws (1) and open cover (2) on enclosure (3).
- b. Remove relay retainers (4).
- c. Remove electromagnetic relays (5).

### REPAIR

Repair at this level of maintenance is by replacement of electromagnetic relays (5).

### ASSEMBLY

- a. Install electromagnetic relays (5).
- b. Install relay retainers (4).
- c. Close cover (2) on enclosure (3) and tighten captive screw (1).
- d. Remove tag and turn on electrical power to interface unit assembly.

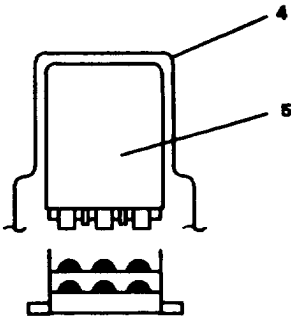
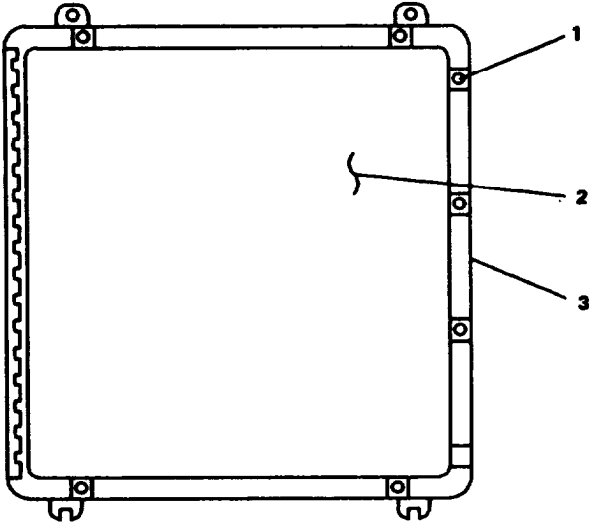


FIGURE 2-126. Interface Unit Assembly.

2-141. Repair Motor Controller Multi-Remote Module. (FIGURE 2-127)

---

This task covers: a. Disassembly, b. Repair, c. Assembly.

---

INITIAL SETUP

Tools

Tool kit, electrician's,  
5180-00-391-1087

Equipment Condition

Secure electrical power to motor controller multi-remote module and tag "Out of Service - Do Not Operate" at ship service switchboard.

Materials/Parts

Solid state switch P/N 91-2003-000  
Solid state switch P/N 91-2000-000  
Warning tag, Item 1, Appendix C

---

DISASSEMBLY

**NOTE**

Prior to performing maintenance at the unit level, intermediate direct support maintenance must first remove the electrical power cables.

- a. Loosen captive screws (1) and open cover (2).
- b. Remove solid state switches (3, 4).

REPAIR

Repair at this level of maintenance is by replacement of solid state switches (3, 4).

ASSEMBLY

- a. Install solid state switches (3, 4).
- b. Close cover (2) and tighten captive screws (1).
- c. Restore power.

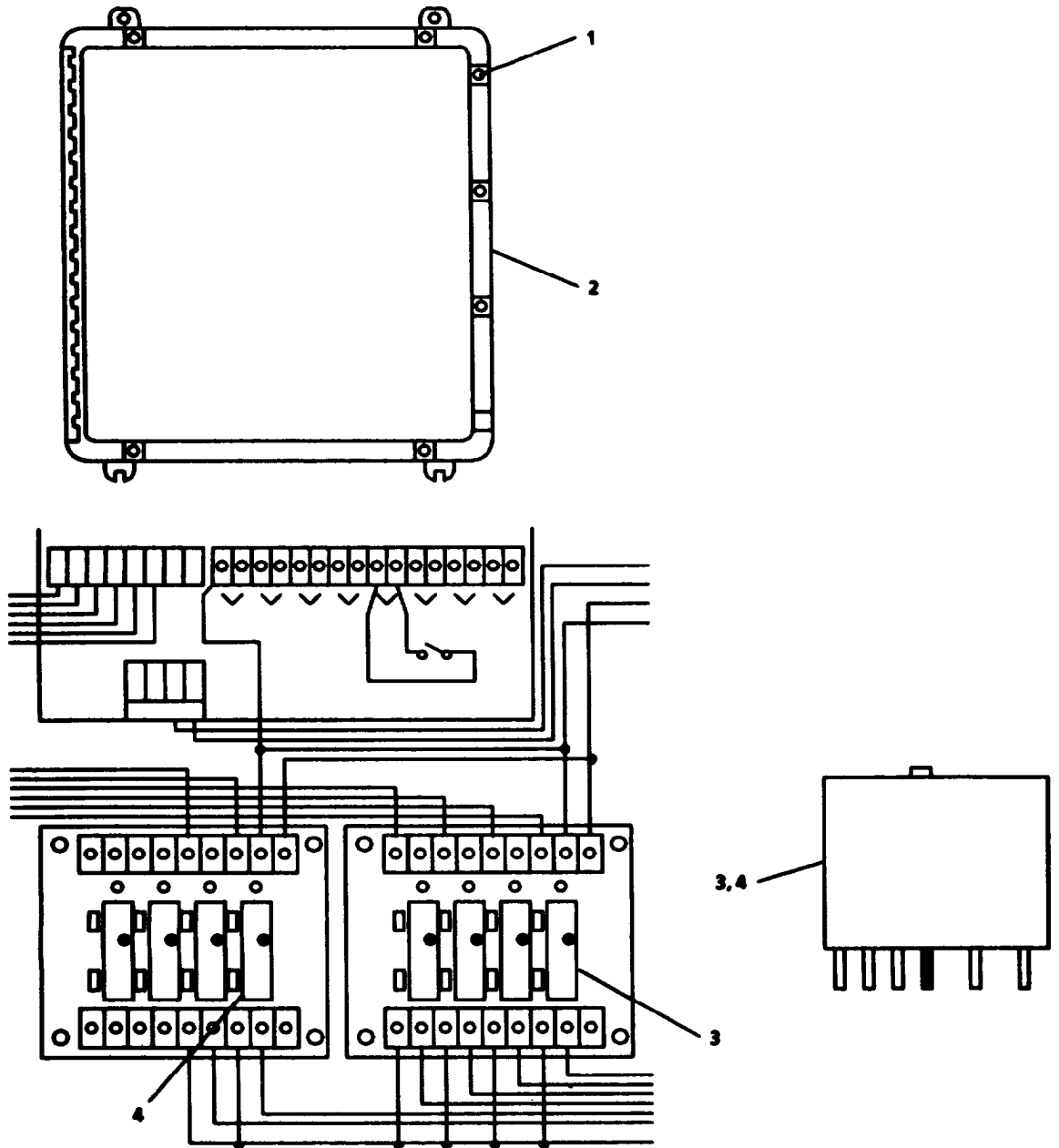


FIGURE 2-127. Multi-Remote Module.

2-142. Repair Engine Order Telegraph System.

---

This task covers: Repair.

---

INITIAL SETUP

Tools

Tool kit, electrician's,  
5180-00-391-1087

Materials/Parts

Warning tag, Item 1, Appendix C

---

Equipment Condition

Electrical power to engine order telegraph system secured and tagged "Out of Service - Do Not Operate" at ship service switchboard. (TM 55-1905-223-10)

REPAIR

Repair of the engine order telegraph system at this level of maintenance is by repair of the components in the system (refer to paragraphs 2-143 through 2-146).

2-143. Repair Bridge Panel Assembly. (FIGURE 2-128)

This task covers: a. Disassembly, b. Repair, c. Assembly.

INITIAL SETUP

Tools

Tool kit, electrician's,  
5180-00-391-1087

Materials/Parts

Warning tag, Item 1, Appendix C  
 Push switch P/N 71-1022-000  
 Incandescent lamp (28 volt)  
     P/N 71-1021-000  
 Light lens (Full Ahead)  
     P/N 71-1022-001  
 Light lens (Half Ahead)  
     P/N 71-1022-002  
 Light lens (Slow Ahead)  
     P/N 71-1022-003  
 Light lens (Dead Slow Ahead)  
     P/N 71-1022-004  
 Light lens (Dead Slow Astern)  
     P/N 71-1022-005  
 Light lens (Half Astern)  
     P/N 71-1022-006  
 Light lens (Half Astern)  
     P/N 71-1022-007  
 Light lens (Full Astern)  
     P/N 71-1022-008

Equipment Condition

Electrical power to engine order telegraph system secured and tagged "Out of Service - Do Not Operate" at ship service switchboard. (TM 55-1905-223-10)

Light lens (Standby)  
     P/N 71-1022-009  
 Light lens (Cancel Standby)  
     P/N 71-1022-010  
 Light lens (Bridge Control)  
     P/N 71-1022-011  
 Light lens (Finished with Engines)  
     P/N 71-1022-012  
 Light lens (Power on Lamp Test)  
     P/N 71-1022-013  
 Light lens (Dimmer)  
     P/N 71-1022-014  
 Light lens (Stop)  
     P/N 71-1022-015  
 Light lens (Port Wrong Direction)  
     P/N 71-1022-016  
 Light lens (STBD Wrong Direction)  
     P/N 71-1022-017  
 Light lens (Communication Failure)  
     P/N 71-1022-018  
 Audible alarm (buzzer)  
     P/N 41-1000-002

DISASSEMBLY

- a. Grasp bridge control lens (1) between thumb and forefinger and squeeze gently until lens pops free. Remove lens.
- b. Remove two incandescent lamps (2) and push switch (3).
- c. Repeat procedures e. and f. for port side bridge control indicator.

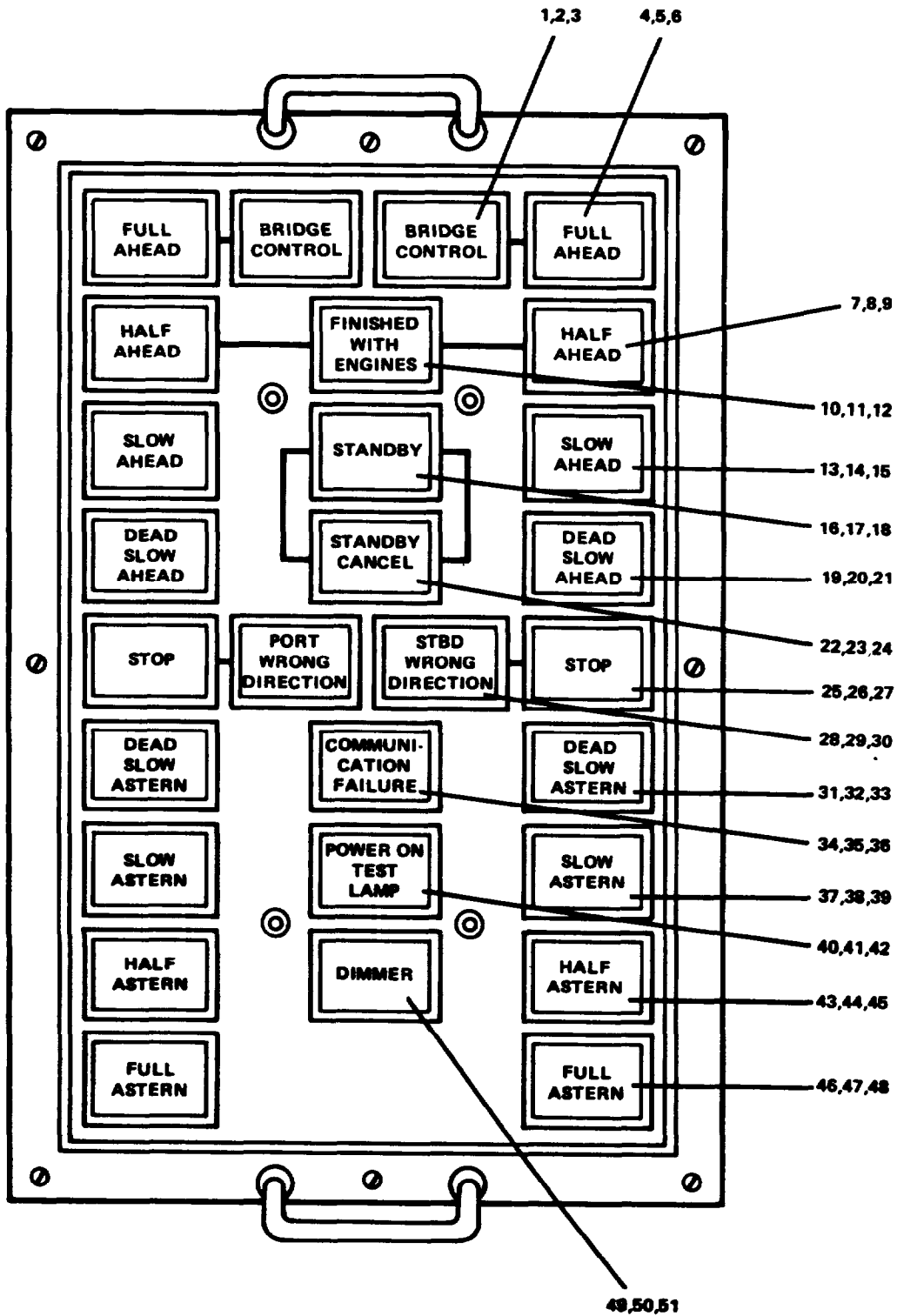


FIGURE 2-128. Bridge Panel Assembly.



- d. Grasps full ahead lens (4) between thumb and forefinger and squeeze gently until lens pops free. Remove lens.
- e. Remove two incandescent lamps (5) and push switch (6).
- f. Repeat procedures h. and i. for port side full ahead indicator.
- g. Grasps half ahead lens (7) between thumb and forefinger and squeeze gently until lens pops free. Remove lens.
- h. Remove two incandescent lamps (8) and push switch (9).
- i. Repeat procedures k. and l. for port side half ahead Indicator.
- j. Grasp finished with engines lens (10) between thumb and forefinger and squeeze gently until lens pops free. Remove lens.
- k. Remove two incandescent lamps (11) and push switch (12).
- l. Grasp slow ahead lens (13) between thumb and forefinger and squeeze gently until lens pops free. Remove lens.
- m. Remove two incandescent lamps (14) and push switch (15).
- n. Repeat procedures p. and q. for port side slow ahead indicator.
- o. Grasp standby lens (16) between thumb and forefinger and squeeze gently until lens pops free. Remove lens,
- p. Remove two incandescent lamps (17) and push switch (18).
- q. Grasp dead slow ahead lens (19) between thumb and forefinger and squeeze gently until lens pops free. Remove lens,
- r. Remove two incandescent lamps (20) and push switch (21).
- s. Repeat procedures u. and v. for port side dead slow ahead indicator.
- t. Grasp standby cancel lens (22) between thumb and forefinger and squeeze gently until lens pops free. Remove lens.
- u. Remove two incandescent lamps (23) and push switch (24).
- v. Grasp stop lens (25) between thumb and forefinger and squeeze gently until lens pops free. Remove lens.
- w. Remove two incandescent lamps (26) and push switch (27).
- x. Repeat procedures v. and w. for port side stop indicator.
- y. Grasp starboard wrong direction lens (28) between thumb and forefinger and squeeze gently until lens pops free. Remove lens.
- z. Remove two incandescent lamps (29) and push switch (30).

## TM 55-1905-223-24-18-1

- aa. Repeat procedures y. and z. for port side port wrong direction indicator.
- ab. Grasp dead slow astern lens (31) between thumb and forefinger and squeeze gently until lens pops free. Remove lens.
- ac. Remove two incandescent lamps (32) and push switch (33).
- ad. Repeat procedures ab. and ac. for port side dead slow astern indicator.
- ae. Grasp communication failure lens (34) between thumb and forefinger and squeeze gently until lens pops free. Remove lens.
- af. Remove two incandescent lamps (35) and push switch (36).
- ag. Grasp slow astern lens (37) between thumb and forefinger and squeeze gently until lens pops free. Remove lens.
- ah. Remove two incandescent lamps (38) and push switch (39).
- ai. Repeat procedures ag. and ah. for port side slow astern indicator.
- aj. Grasp power on lamp test lens (40) between thumb and forefinger and squeeze until lens pops free. Remove lens.
- ak. Remove two incandescent lamps (41) and push switch (42).
- al. Grasp half astern lens (43) between thumb and forefinger and squeeze gently until lens pops free. Remove lens.
- am. Remove two incandescent lamps (44) and push switch (45).
- an. Repeat procedures al. and am. for port side half astern indicator.
- ao. Grasp full astern lens (46) between thumb and forefinger and squeeze gently until lens pops free. Remove lens.
- ap. Remove two incandescent lamps (47) and push switch (48).
- aq. Repeat procedures ao. and ap. for port side full astern indicator.
- ar. Grasp dimmer lens (49) between thumb and forefinger and squeeze gently until lens pops free. Remove lens.
- as. Remove two incandescent lamps (50) and push switch (51).

### **REPAIR**

Repair at this level of maintenance is by replacement of light lenses (1, 7, 10, 13, 16, 19, 22, 25, 28, 31, 34, 37, 40, 43, 46, and 49), incandescent lamps (2, 5, 8, 11, 14, 17, 20, 23, 26, 29, 32, 35, 38, 41, 44, 47, and 50), push switches (3, 6, 9, 12, 15, 18, 21, 24, 27, 30, 33, 36, 39, 42, 45, 48, and 51).

**ASSEMBLY**

- a. Install push switch (51) and two incandescent lamps (50).
- b. Install dimmer lens (49).
- c. Install push switch (48) and two incandescent lamps (47).
- d. Install full astern lens (46).
- e. Repeat procedures c. and d. for port side full astern indicator.
- f. Install push switch (45) and two incandescent lamps (44).
- g. Install half astern lens (43).
- h. Repeat procedures f. and g. for port side half astern indicator.
- i. Install push switch (42) and two incandescent lamps (41).
- j. Install power on lamp test lens (40).
- k. Install push switch (39) and two incandescent lamps (38).
- l. Install slow astern lens (37).
- m. Repeat procedures k. and l. for port side slow astern indicator.
- n. Install push switch (36) and two incandescent lamps (35).
- o. Install communication failure lens (34).
- p. Install push switch (33) and two incandescent lamps (32).
- q. Install dead slow astern lens (31).
- r. Repeat procedures p. and q. for port side dead slow astern indicator.
- s. Install push switch (30) and two incandescent lamps (29).
- t. Install starboard wrong direction lens (28).
- u. Repeat procedures s. and t. for port side port wrong direction indicator.
- v. Install push switch (27) and two incandescent lamps (26).
- w. Install stop lens (25).
- x. Repeat procedures v. and w. for port side stop indicator.
- y. Install push switch (24) and two incandescent lamps (23).
- z. Install standby cancel lens (22).

**TM 55-1905-223-24-18-1**

- aa. Install push switch (21) and two incandescent lamps (20).
- ab. Install dead slow ahead lens (19).
- ac. Repeat procedures aa. and ab. for port side dead slow ahead indicator.
- ad. Install push switch (18) and two incandescent lamps (17).
- ae. Install standby lens (16).
- af. Install push switch (15) and two incandescent lamps (14).
- ag. Install slow ahead lens (13).
- ah. Repeat procedures af. and ag. for port side slow ahead indicator.
- ai. Install push switch (12) and two incandescent lamps (11).
- aj. Install finished with engines lens (10).
- ak. Install push switch (9) and two incandescent lamps (8).
- al. Install half ahead lens (7).
- am. Repeat procedures ak. and al. for port side half ahead indicator.
- an. Install push switch (6) and two incandescent lamps (5).
- ao. Install full ahead lens (4).
- ap. Repeat procedures ao. and ap. for port side full ahead indicator.
- aq. Install push switch (3) and two incandescent lamps (2).
- ar. Install bridge control lens (1).
- as. Repeat procedures aq. and ar. for port side bridge control indicator.

---

2-144. Repair Central Processing Unit. (FIGURE 2-129)

---

This task covers: a. Disassembly, b. Repair, c. Assembly.

---

INITIAL SETUP

Tools

Tool kit, electrician's,  
5180-00-391-1087

Materials/Parts

Cartridge fuse P/N 91-6009-003  
Warning tag, Item 1, Appendix C

Equipment Condition

Electrical power to engine order telegraph system secured and tagged "Out of Service - Do Not Operate" at ship service switchboard. (TM 55-1905-223-10)

---

DISASSEMBLY

- a. Loosen captive screws (1) and open cover (2) on enclosure (3).
- b. Remove cartridge fuse (4).

REPAIR

Repair at this level of maintenance is by replacement of cartridge fuse (4).

ASSEMBLY

- a. Install cartridge fuse (4).
- b. Close cover (2) on enclosure (3) and tighten captive screws (1).
- c. Restore power to central processing unit and remove tag.

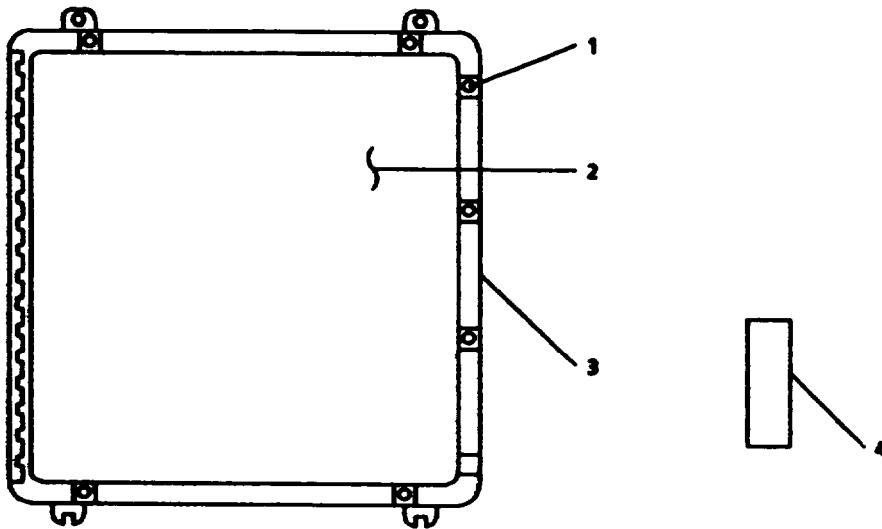


FIGURE 2-129. Central Processing Unit, 02-10350-000.

---

2-145. Repair Engine Room Multi-Remote Module. (FIGURE 2-130)

---

This task covers: a. Disassembly, b. Repair, c. Assembly.

---

### INITIAL SETUP

#### Tools

Tool kit, electrician's,  
5180-00-391-1087

#### Materials/Parts

Pressure switch (4)  
P/N 61-4250-000  
Warning tag, Item 1, Appendix C

#### Equipment Condition

Electrical power to engine order telegraph system secured and tagged "Out of Service - Do Not Operate" at ship service switchboard. (TM 55-1905)-223-10)

---

### DISASSEMBLY

- a. Tag and disconnect electrical leads.
- b. Remove pressure switches (1 through 4).

### REPAIR

Repair at this level of maintenance is by replacement of pressure switches (1 through 4).

### ASSEMBLY

- a. Install pressure switches (1 through 4).
- b. Remove tags and connect electrical leads.

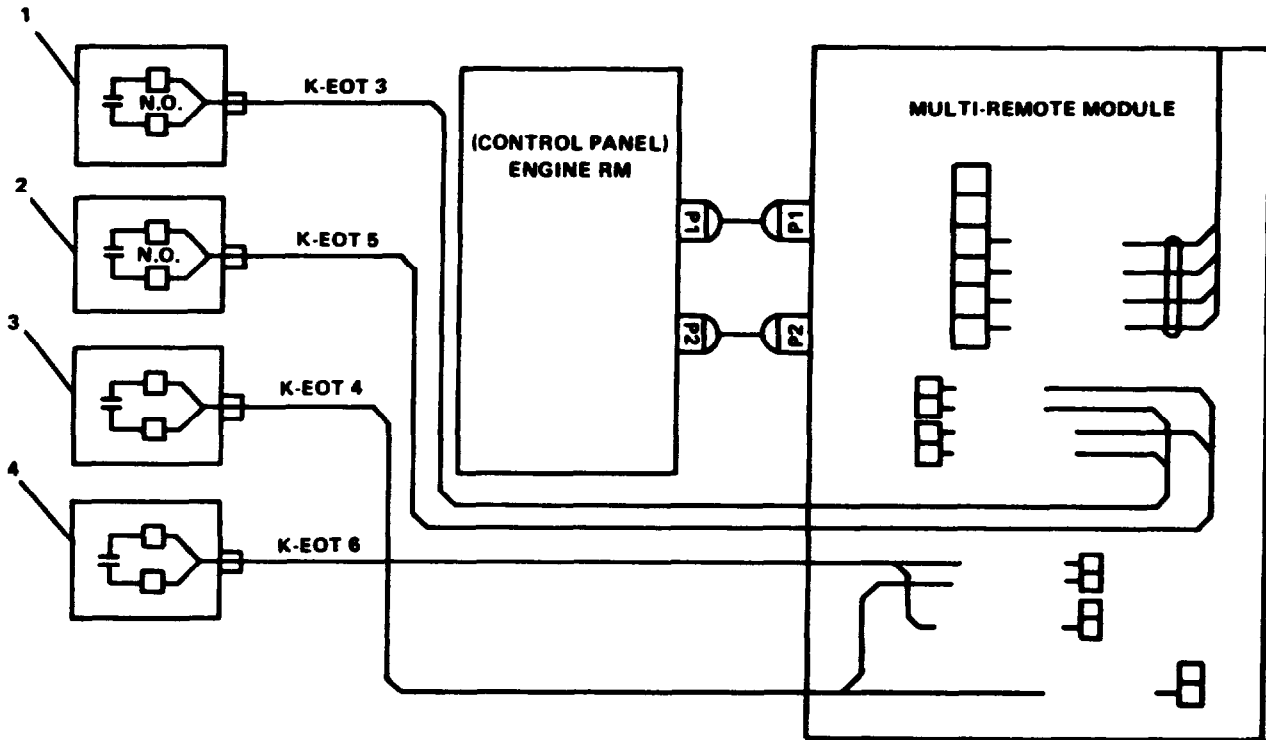


FIGURE 2-130. Engine Room Multi-Remote Module.



2-146. Repair Engine Room Panel Assembly.

This task covers: a. Disassembly, b. Repair, c. Assembly.

INITIAL SETUP

Tools

Tool kit, electrician's,  
5180-00-391-1087

Materials/Parts

Warning tag, Item 1, Appendix C  
 Push switch P/N 71-1022-000  
 Incandescent lamp (28 volt)  
     P/N 71-1021-000  
 Light lens (Full Ahead)  
     P/N 72-1022-001  
 Light lens (Half Ahead)  
     P/N 71-1022-002  
 Light lens (Slow Ahead)  
     P/N 71-1022-003  
 Light lens (Dead Slow Ahead)  
     P/N 71-1022-004  
 Light lens (Dead Slow Astern)  
     P/N 71-1022-005  
 Light lens (Half Astern)  
     P/N 71-1022-006  
 Light lens (Half Astern)  
     P/N 71-1022-007  
 Light lens (Full Astern)  
     P/N 71-1022-008

Equipment Condition

Electrical power to engine order telegraph system secured and tagged "Out of Service - Do Not Operate" at ship service switchboard. (TM 55-1905-223-10)

Light lens (Standby)  
     P/N 71-1022-009  
 Light lens (Cancel Standby)  
     P/N 71-1022-010  
 Light lens (Bridge Control)  
     P/N 71-1022-011  
 Light lens (Finished with Engines)  
     P/N 71-1022-012  
 Light lens (Power on Lamp Test)  
     P/N 71-1022-013  
 Light lens (Dimmer)  
     P/N 71-1022-014  
 Light lens (Stop)  
     P/N 71-1022-015  
 Light lens (Port Wrong Direction)  
     P/N 71-1022-016  
 Light lens (STBD Wrong Direction)  
     P/N 71-1022-017  
 Light lens (Communication Failure)  
     P/N 71-1022-018  
 Audible alarm (buzzer)  
     P/N 41-1000-002

**NOTE**

Refer to paragraph 2-143 for Disassembly, Repair and Assembly procedures.

2-147. Replace/Repair Bow Ramp Control System.

---

This task covers: a. Removal, b. Repair, c. Replacement.

---

INITIAL SETUP

Tools

Tool kit, electrician's,  
5180-00-391-1087

Materials/Parts

Warning tags, Item 1, Appendix C

---

Equipment Condition

Electrical power to Bow Ramp Control system secured and tagged "Out of Service - Do Not Operate".  
(TM 55-1905-223-10)

**NOTE**

Replacement and Repair of the bow ramp control system is by replacement and repair of the components in the system (refer to paragraphs 2-148 through 2-150).

---

## 2-148. Replace/Repair Control Panel (Winch Room).

---

This task covers: a. Removal, b. Disassembly, c. Repair, d. Assembly, e. Replacement.

---

### INITIAL SETUP

#### Tools

Tool kit, electrician's,  
5180-00-391-1087

#### Equipment Condition

Power to bow ramp control system  
secured and tagged "Out of Service -  
Do Not Operate." (TM 55-1905-223-10)

#### Materials/Parts

Push switch (green) P/N 00H-R1A  
Push switch (red) P/N 00H-R6A4  
Push switch (black) P/N 00H-R2A  
Indicator light (green) P/N 00H-PR16G  
Indicator light (amber) P/N 00H-PR16A  
Indicator light (red) P/N 00H-PR16R  
Toggle switch P/N 00T-T2SB21  
Electromagnetic relay P/N 00H-C24A1  
Electromagnetic relay P/N 00HG471  
Warning tags, Item 1, Appendix C

---

### REMOVAL (FIGURE 2-131)

- a. Tag and disconnect electrical power cable (3).
- b. Remove four machine screws (2).
- c. Remove control panel (1) from bulkhead.

### DISASSEMBLY (FIGURE 2-132)

- a. Open door (2, Sheet 1) of control panel by unscrewing door fasteners (4).
- b. Tag and disconnect, electrical leads to high, temp indicator (5) tension indicator (7), tension switch (9), toggle switch (11), stop switch (13), start switch (15), and run indicator (17).
- c. Tag and disconnect electrical leads to electromagnetic relays (18, 19, Sheet 2).
- d. Remove electromagnetic relays.
- e. Unscrew retaining ring (3) and remove indicator light (5) from high temp indicator.

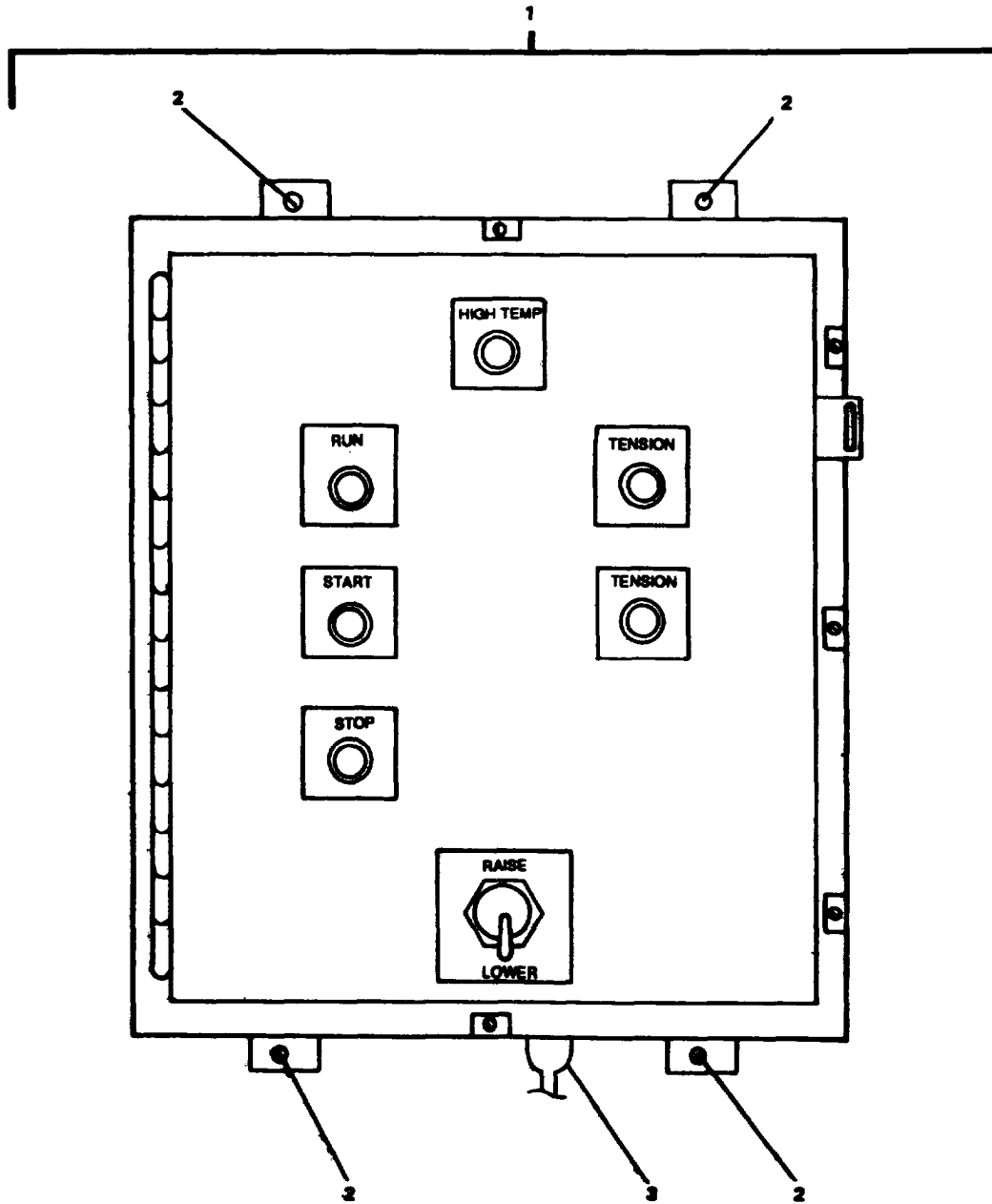


FIGURE 2-131. Control Panel (Winch Room) Removal.

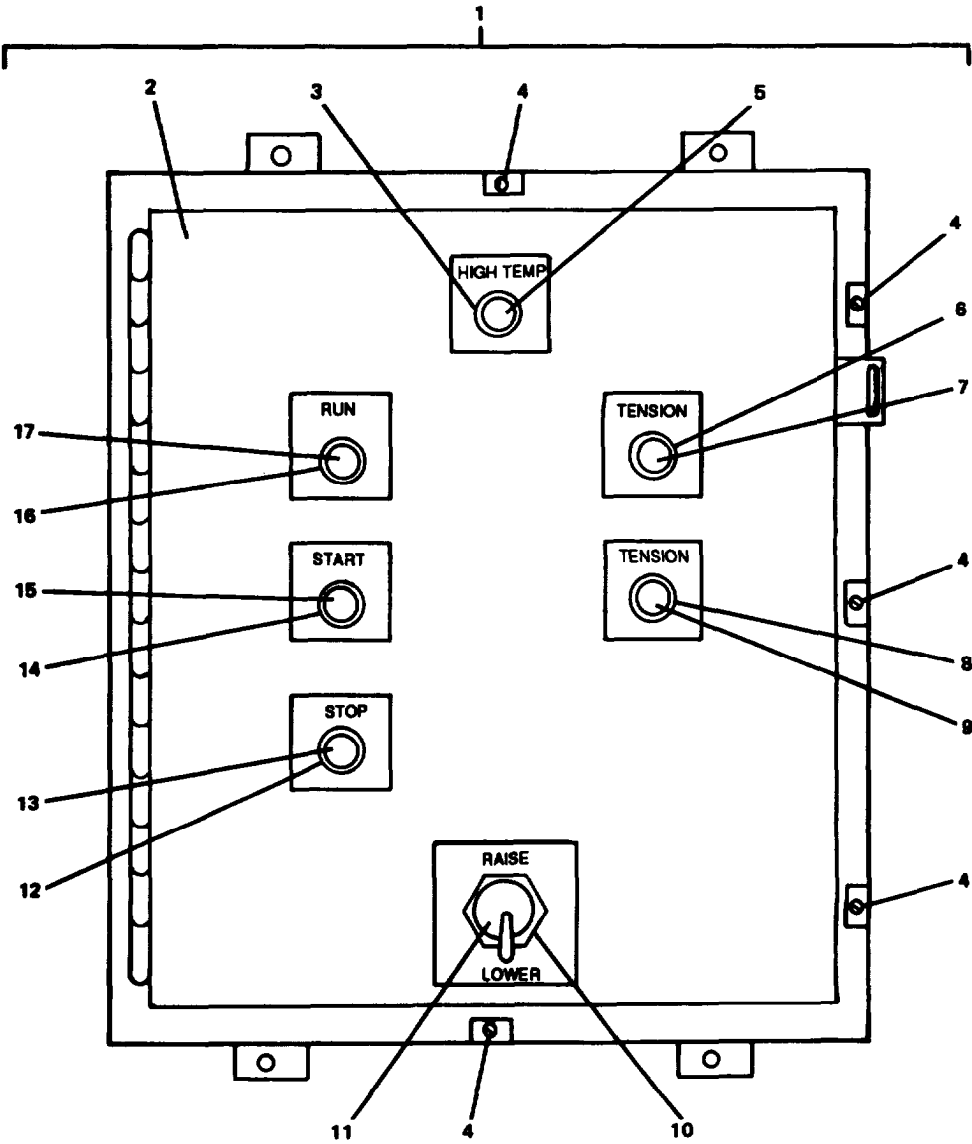


FIGURE 2-132. Control Panel (Winch Room) Disassembly (Sheet 1 of 2).

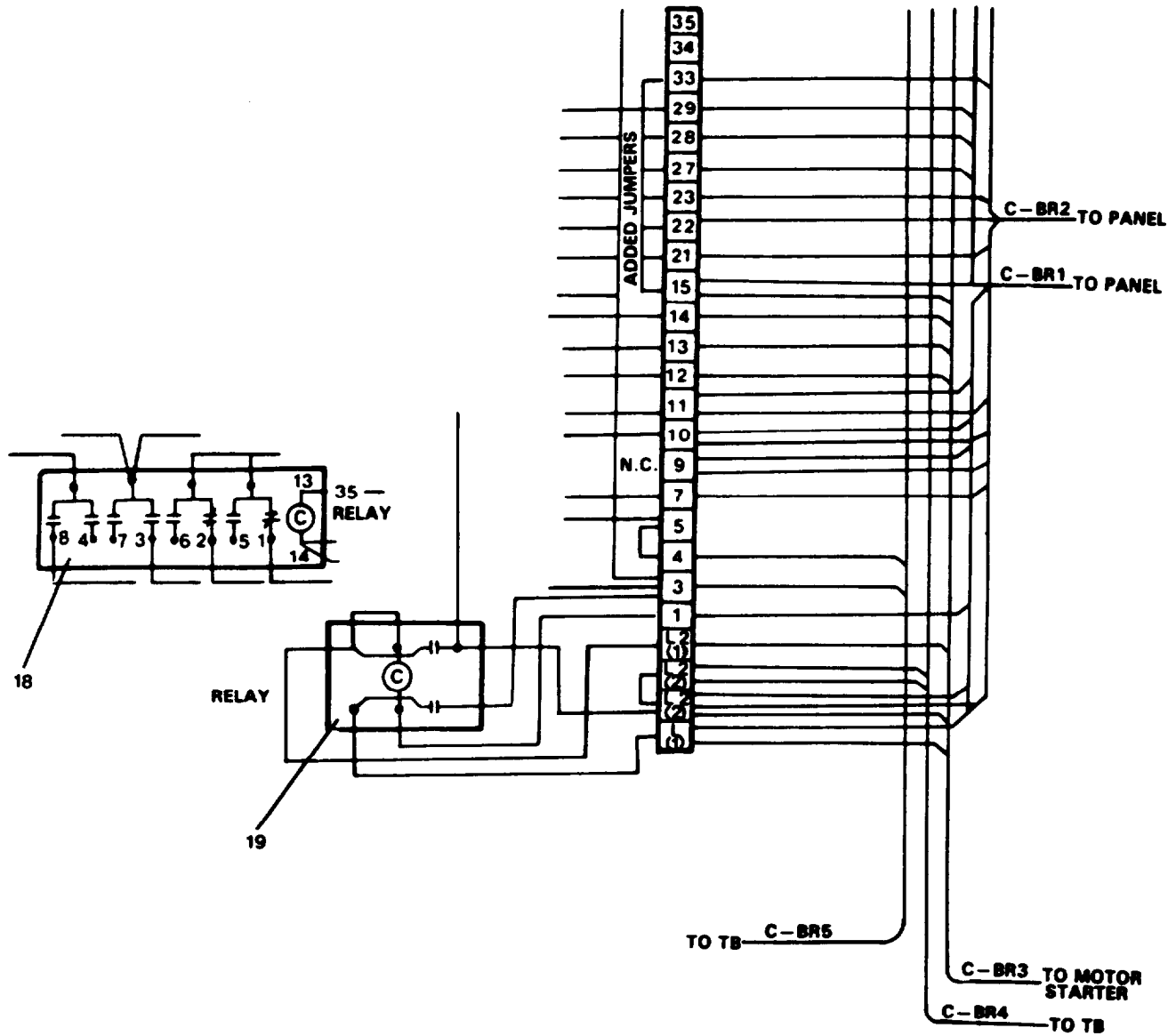


FIGURE 2-132. Control Panel (Winch Room) Disassembly (Sheet 2 of 2).

- f. Unscrew retaining ring (6) and remove indicator light (7) from tension indicator.
- g. Unscrew retaining ring (8) and remove tension push switch (9).
- h. Unscrew hexagon nut (10) and remove toggle switch (11).
- i. Unscrew retaining ring (12) and remove stop push switch (13).
- j. Unscrew retaining ring (14) and remove start push switch (15).
- k. Unscrew retaining ring (16) and remove indicator light (17) from run indicator.

### **REPAIR**

Repair at this level of maintenance is by replacement of indicator lights (5, 7, and 17), push switches (9, 13, and 15), toggle switch (11), and electromagnetic relays (18, 19).

### **ASSEMBLY**

- a. Install run indicator light (17) and secure with retaining ring (16).
- b. Install start push switch (15) and secure with retaining ring (14).
- c. Install stop push switch (13) and secure with retaining ring (12).
- d. Install toggle switch (11) and secure with hexagon nut (10).
- e. Install tension push switch (9) and secure with retaining ring (8).
- f. Install tension indicator light (7) and secure with retaining ring (6).
- g. Install high temp indicator light (5) and secure with retaining ring (3).
- h. Install electromagnetic relays (18, 19). Connect electrical leads and remove tags.
- i. Connect electrical leads to run indicator (17), start switch (15), stop switch (13), toggle switch (11), tension switch (9), tension indicator (7), and high temp indicator (5). Remove tags.
- j. Close door (2) and secure with door fasteners (4).

### **REPLACEMENT** (FIGURE 2-131)

- a. Position control panel (1) on bulkhead and secure with four machine screws (2).
- b. Connect electrical power cable (3) and remove tags.
- c. Restore power to control panel and remove tags.

2-149. Replace/Repair Bow Ramp Control Panel (Pilothouse Console). (FIGURE 2-133)

---

This task covers: a. Removal, b. Disassembly, c. Repair, d. Assembly,  
e. Replacement.

---

### INITIAL SETUP

#### Tools

Tool kit, electrician's,  
5180-00-391-1087

#### Equipment Condition

Power to bow ramp control system secured  
and tagged "Out of Service - Do Not  
Operate." (TM 55-1905-223-10)

#### Materials/Part

Rotary switch P/N 008-69070  
Push switch P/N 00H-R1A  
Push switch P/N 00H-R6A  
Push switch P/N 00H-R2A  
Indicator light (green) P/N 00H-PR16G  
Indicator light (amber) P/N 00H-PR16A  
Indicator light (red) P/N 00H-PR16R  
Toggle switch P/N 00T-T2SB21  
Cartridge fuse P/N RN5  
Warning tags, Item 1, Appendix C

---

### REMOVAL

- a. Disconnect wires and tag.
- b. Remove four mounting screws (3) securing bow ramp control panel (1) in pilot house control console.
- c. Remove panel from console.

### DISASSEMBLY

- a. Tag and disconnect electrical leads to rotary switch (5), tension indicator light (7), tension push switch (11), toggle switch (14), stop push switch (16), start push switch (18), run indicator light (20), and high temp indicator light (9).
- b. Unscrew retaining ring (4) and remove rotary switch (5).
- c. Unscrew retaining ring (6) and remove tension indicator light (7).
- d. Unscrew retaining ring (8) and remove high temp indicator light (9).
- e. Unscrew retaining ring (10) and remove tension push switch (11).



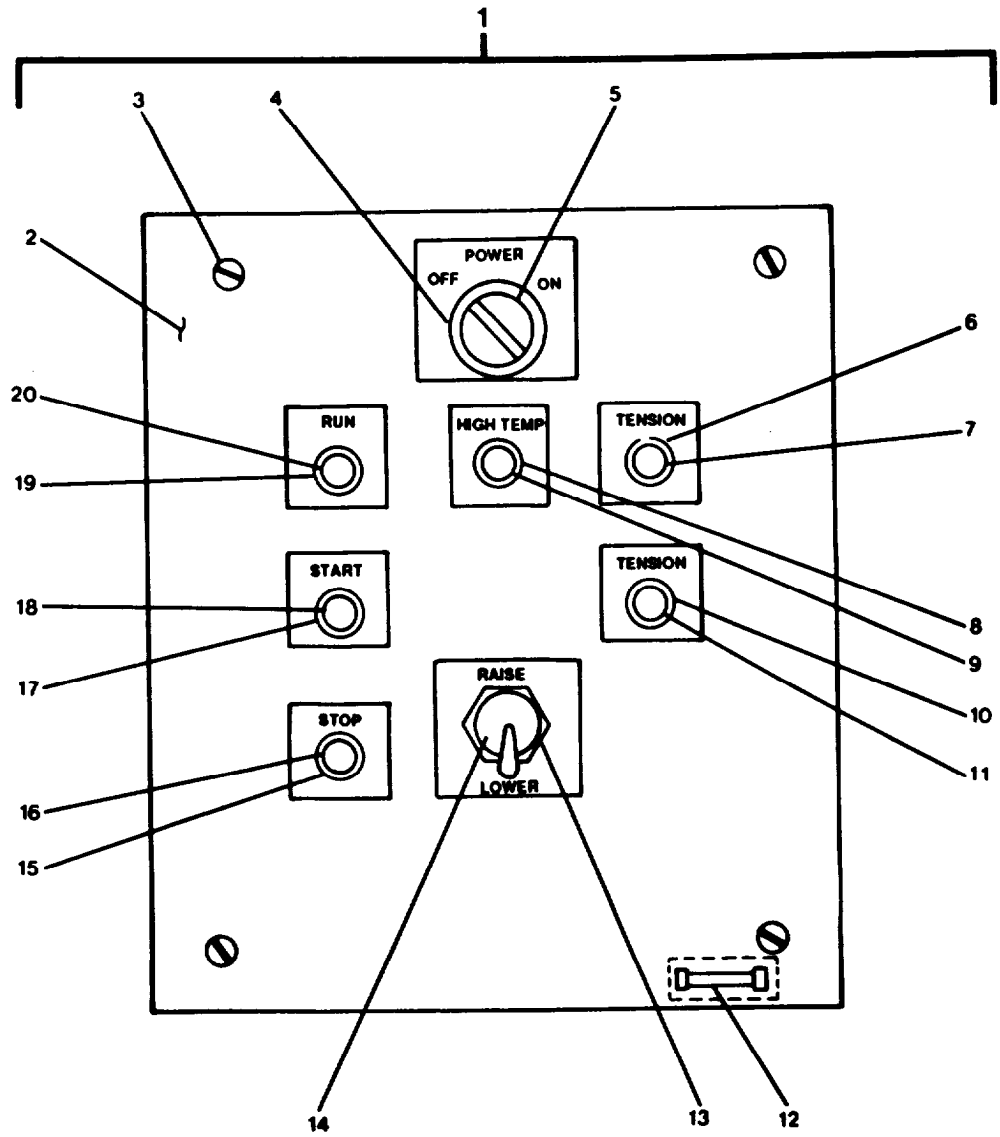


FIGURE 2-133. Bow Ramp Control Panel.

## **TM 55-1905-223-24-18-1**

- f. Remove fuse (12).
- g. Unscrew hexagon nut (13) and remove toggle switch (14).
- h. Unscrew retaining ring (15) and remove stop push switch (16).
- i. Unscrew retaining ring (17) and remove start push switch (18).
- j. Unscrew retaining ring (19) and remove run indicator light (20).

### **REPAIR**

Repair at this level of maintenance is by replacement of rotary switch (5), indicator lights (7, 9, and 20), push switches (11, 16, and 18), toggle switch (14), and fuse (12).

### **ASSEMBLY**

- a. Install run indicator light (20) and secure with retaining ring (19).
- b. Install start push switch (18) and secure with retaining ring (17).
- c. Install stop push switch (16) and secure with retaining ring (15).
- d. Install toggle switch (14) and secure with hexagon nut (13).
- e. Install fuse (12).
- f. Install tension push switch (11) and secure with retaining ring (10).
- g. Install high temp indicator light (9) and secure with retaining ring (8).
- h. Install tension indicator light (7) and secure with retaining ring (6).
- i. Install rotary switch (5) and secure with retaining ring (4).
- j. Connect electrical leads to rotary switch (5), tension indicator (7), tension push switch (11), toggle switch (14), stop push switch (16), start push switch (18), run indicator (20), and high temp indicator (9).
- k. Remove tags.

### **REPLACEMENT**

- a. Install bow ramp control panel (2) in pilothouse control console and secure with four mounting screws (3).
- b. Restore power to control panel and remove tags.

---

2-150. Replace/Repair Bow Ramp Control Panel (Forecastle). (FIGURE 2-134)

---

This task covers: a. Removal, b. Disassembly, c. Repair, d. Assembly, e. Replacement.

---

### INITIAL SETUP

#### Tools

Tool kit, electrician's,  
5180-00-391-1087

#### Equipment Condition

Power to bow ram control system secured and tagged "Out of Service - Do Not Operate", at ship service switchboard. (TM 55-1905-223-10)

#### Materials/Parts

Push switch P/N 00H-R1A  
Push switch P/N 00H-R6A  
Push switch P/N 00H-R2A  
Indicator light (green) P/N 00H-PR16G  
Indicator light (amber) P/N 00H-PR16A  
Indicator light (red) P/N 00H-PR16R  
Toggle switch P/N 00T-T2SB21  
Warning tags, Item 1, Appendix C

---

### REMOVAL

- a. Tag and disconnect electrical power cable (3, Sheet 1).
- b. Remove four machine screws (2).
- c. Remove control panel (1) from bulkhead.

### DISASSEMBLY

- a. Loosen eight screws (3) and slide door latches (4) off of lip (5, Sheet 2).
- b. Remove door (2).
- c. Tag and disconnect electrical leads to high temp indicator (7), tension indicator (9), tension push switch (11), toggle switch (13), stop push switch (15), start push switch (17), and run indicator (19).
- d. Unscrew retaining ring (6) and remove high temp indicator (7).
- e. Unscrew retaining ring (8) and remove tension indicator (9).
- f. Unscrew retaining ring (10) and remove tension push switch (11).

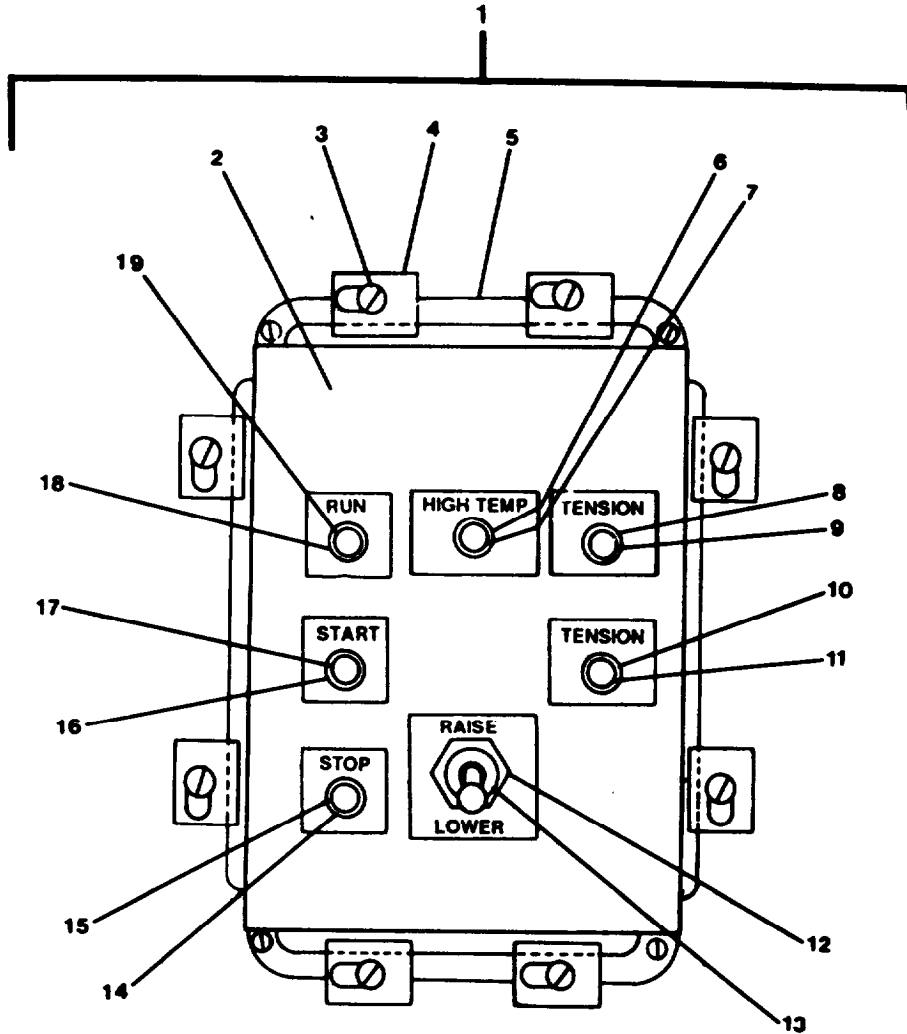


FIGURE 2-134. Bow Ramp Control Panel (Forecastle) (Sheet 1 of 2).

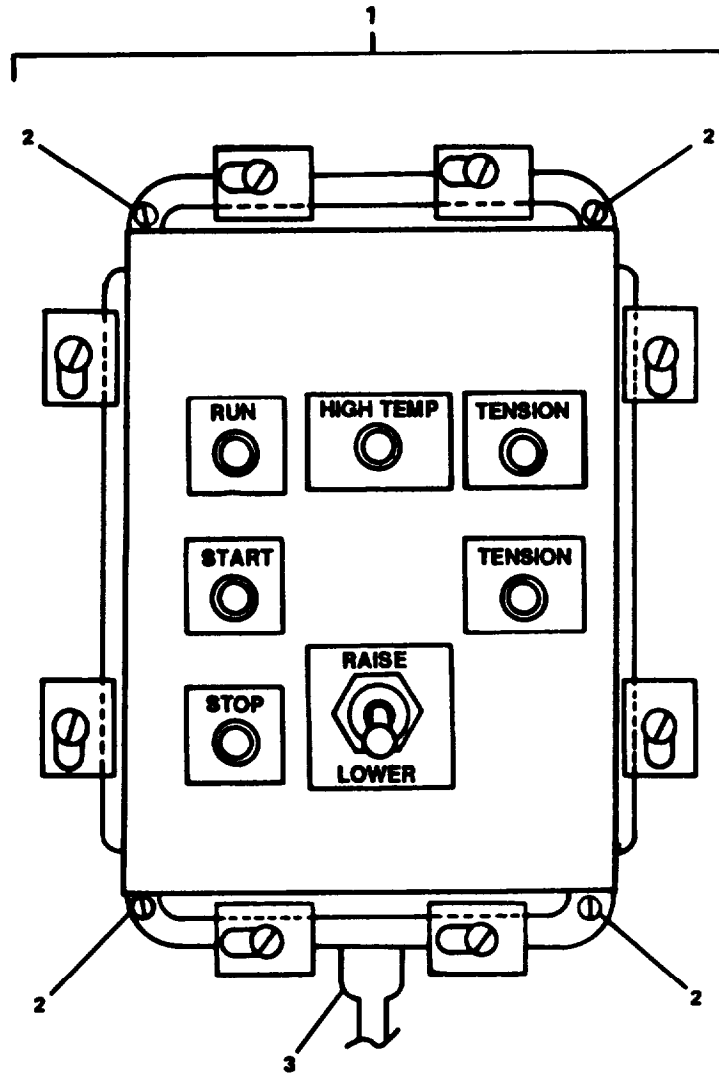


FIGURE 2-134. Bow Ramp Control Panel (Forecastle) (Sheet 2 of 2).

- g. Unscrew hexagon nut (12) and remove toggle switch (13).
- h. Unscrew retaining ring (14) and remove stop push switch (15).
- i. Unscrew retaining ring (16) and remove start push switch (17).
- j. Unscrew retaining ring (18) and remove run indicator (19).

**REPAIR**

Repair at this level of maintenance is by replacement of indicator lights (7, 9, and 19) push switches (11, 15 and 17), and toggle switch (13).

**ASSEMBLY**

- a. Install run indicator light (19) and secure with retaining ring (18).
- b. Install start push switch (17). and secure with retaining ring (16).
- c. Install stop push switch (15) and secure with retaining ring (14).
- d. Install toggle switch (13) and secure with hexagon nut (12).
- e. Install tension push switch (11) and secure with retaining ring (10).
- f. Install tension indicator light (9) and secure with retaining ring (8).
- g. Install high temp indicator light (7) and secure with retaining ring (6).
- h. Connect electrical leads to run indicator (19), start push switch (17), stop push switch (15), toggle switch (13), tension push switch (11), tension indicator (9), and high temp indicator (7).
- i. Replace door (2) and secure with door latches (4) and screws (3, Sheet 1).
- j. Restore power to control panel and remove tags.

**REPLACEMENT**

- a. Position control panel on bulkhead and secure-with four machine screws (2, Sheet 1).
- b. Connect electrical power cable (3) and remove tags.
- c. Restore power to control panel and remove tags.

---

2-151. Repair Fire Detection System. (FIGURE 2-135)

---

This task covers: a. Disassembly, b. Repair, c. Assembly.

---

### INITIAL SETUP

#### Tools

Tool kit, electrician's,  
5180-00-391-1087

#### Materials/Parts

Solid state relay P/N 8501-X0-80-120  
Warning light P/N 50A-N5  
Solid state relay P/N 8501-X0-20-120  
Warning light (strobe beacon)  
P/N 52EXA-N5  
Warning tags, Item 1, Appendix C

---

#### Equipment Condition

Electrical power to Fire Detection System OFF at EP102; circuit breaker 15 tagged "Out of Service - Do Not Operate." (TM 55-1905-223-10)

### WARNING

Notify the bridge that the fire. detection system will be secured for an extended period of time for maintenance.

### DISASSEMBLY

- a. Unplug solid state relay (3) and remove from enclosure (2, Sheet 1).
- b. Tag and disconnect electrical leads (4) to warning lights (1).
- c. Remove mounting hardware and remove warning lights (1).
- d. Unplug solid state relay (6) and remove from enclosure (5, Sheet 2).
- e. Tag and disconnect electrical leads (7) to warning light (9).
- f. Remove mounting hardware securing warning light (9) to connector box (8).
- g. Remove warning light (strobe beacon) (9).

### REPAIR

Repair at this level of maintenance is by replacement of solid state relays (3, 6) and warning lights (1, 9).

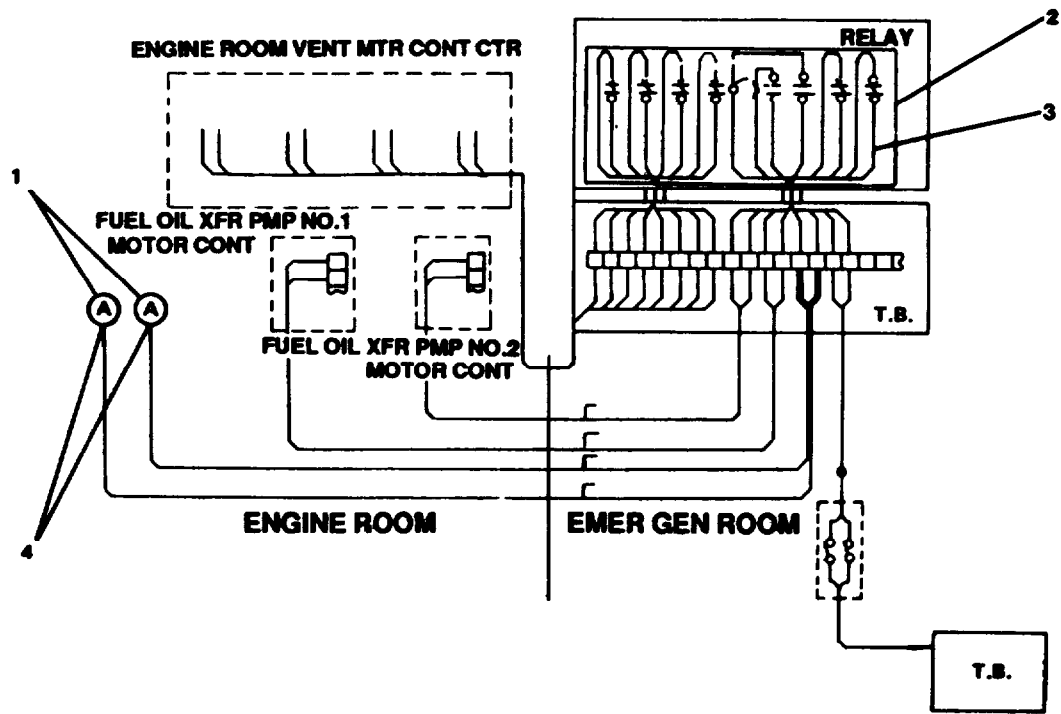


FIGURE 2-135. Fire Detection System (Sheet 1 of 2).



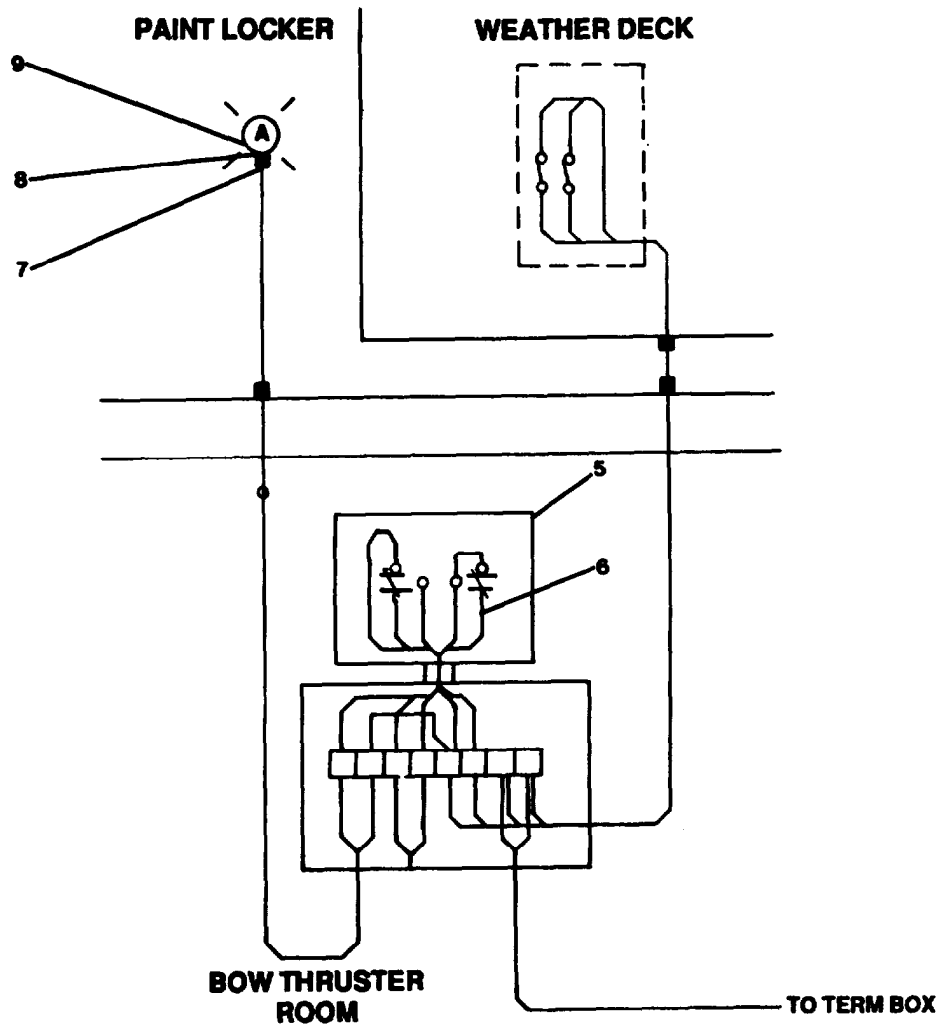


FIGURE 2-135. Fire Detection System (Sheet 2 of 2).

**ASSEMBLY**

- a. Install warning light (strobe beacon) (9) on connector box (8) and secure with mounting hardware.
- b. Connect electrical leads (7) to warning light. Remove tags.
- c. Plug in solid state relay (6) in slot in enclosure (5).
- d. Install warning lights (1) and secure with mounting hardware (Sheet 1).
- e. Connect electrical leads (4) to warning lights. Remove tags.
- f. Plug in solid state relay (3) in slot in enclosure (2).
- g. Restore power to fire detection system at EP102 circuit breaker 15 and remove tags.
- h. Notify the bridge that maintenance on the fire detection system is completed.

---

## 2-152.. Repair Fire Detection Control Panel with Thermostats. (FIGURE 2-136)

---

This task covers: a. Disassembly, b. Repair, c. Assembly.

---

### INITIAL SETUP

#### Tools

Tool kit, electrician's,  
5180-00-391-1087

#### Equipment Condition

Electrical power to fire detection control panel OFF at EP 102; circuit breaker 16 tagged "Out of Service - Do Not Operate."

#### Materials/Parts

Lever switch P/N MS-51 (15)  
Thermostatic switch P/N 27021-o (15)  
Electrical bell P/N BDC-1024  
Thermostatic switch P/N 27121-20 (2)  
Warning tags, Item 1, Appendix C

---

### WARNING

Notify the bridge that the fire detection system will be secured for an extended period of time for maintenance.

### DISASSEMBLY

- a. Tag and disconnect electrical leads to thermostatic switches.
- b. Remove mounting hardware securing thermostatic switches to junction boxes (2).
- c. Remove thermostatic switch (1).
- d. Tag and disconnect electrical leads to lever switches.
- e. Remove mounting hardware on junction box covers (4) securing lever switches.
- f. Remove lever switch (3).
- g. Tag and disconnect electrical leads to lever switches.
- h. Remove mounting hardware securing lever switches to surface mounting boxes (5).
- i. Remove lever switch (7).

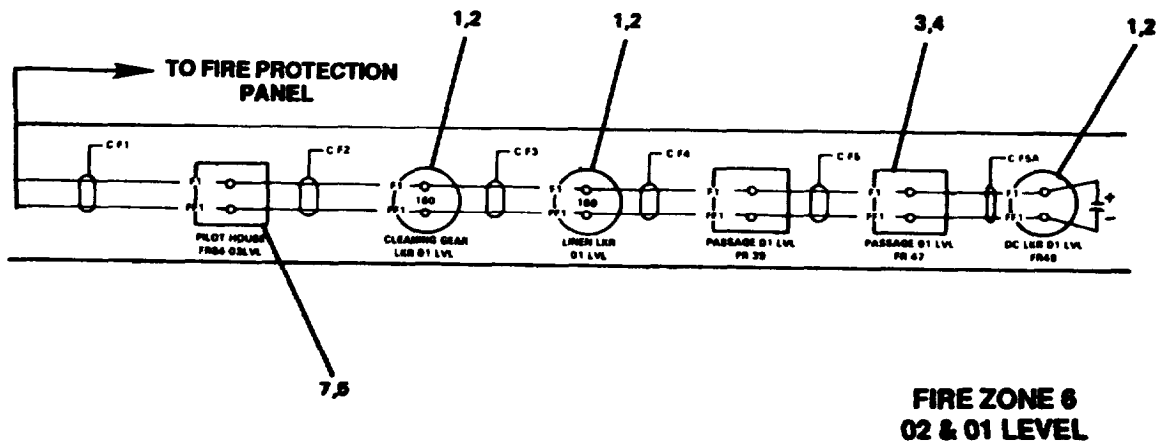


FIGURE 2-136. Fire Detection Control Panel with Thermostats (Sheet 1 of 4).

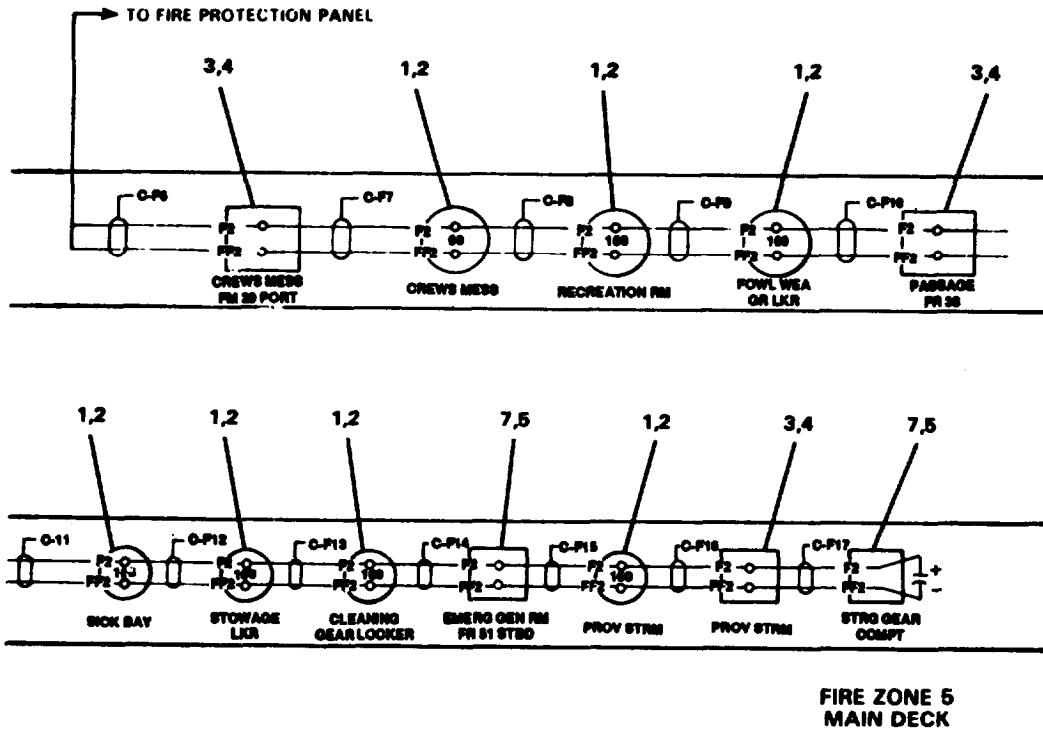


FIGURE 2-136. Fire Detection Control Panel with Thermostats (Sheet 2 of 4).

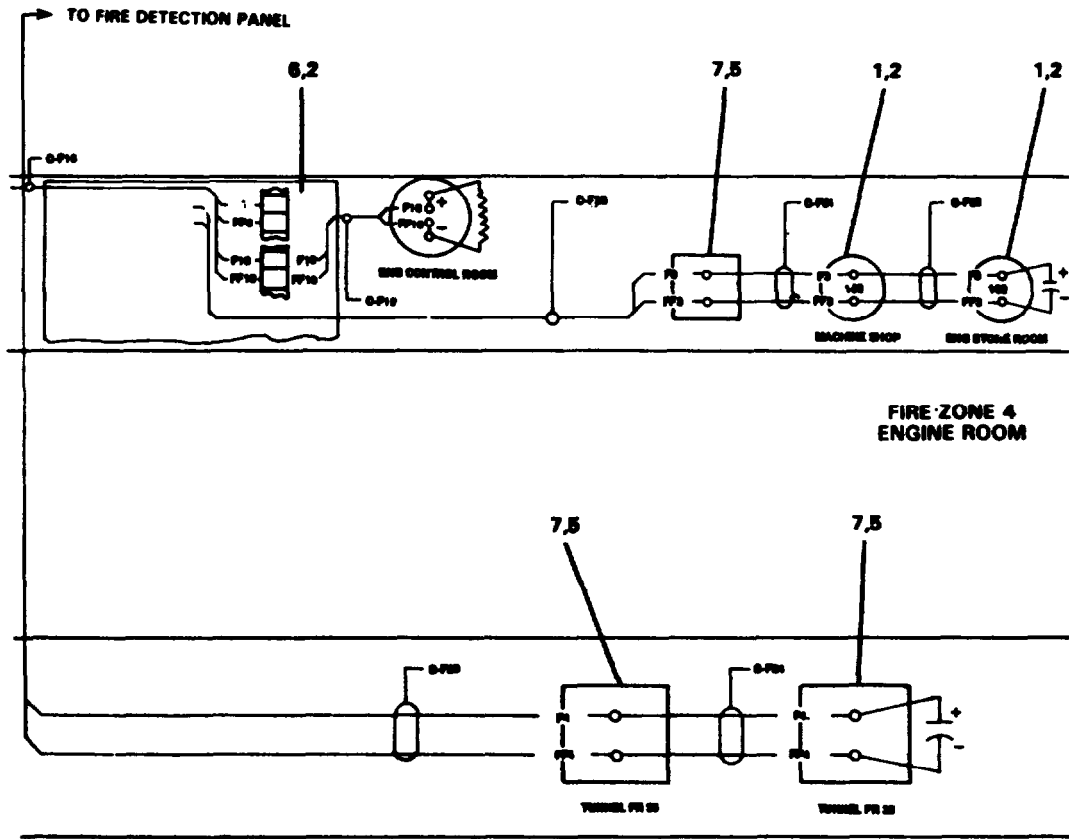


FIGURE 2-136. Fire Detection Control Panel with Thermostats (Sheet 3 of 4).

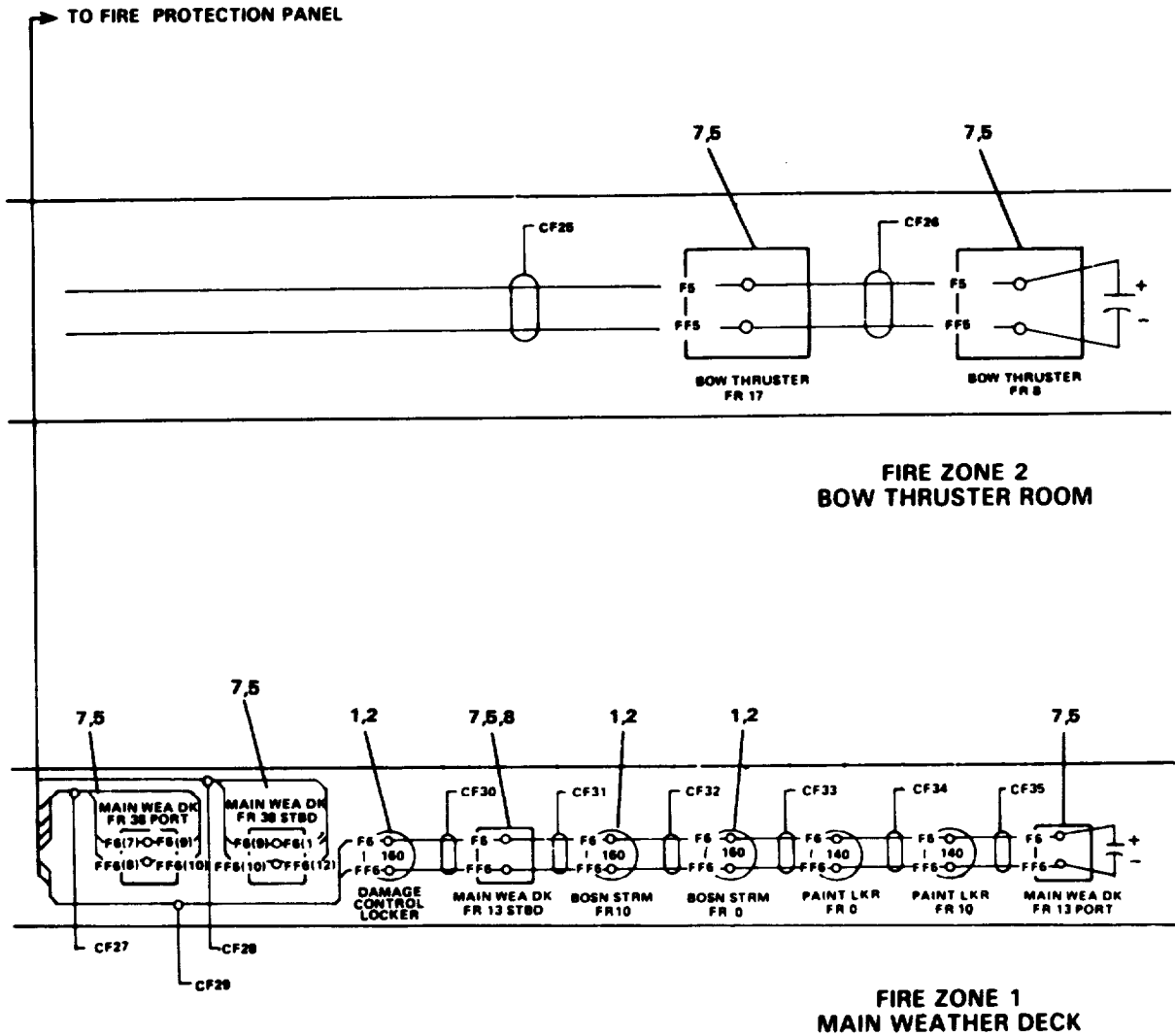


FIGURE 2-136. Fire Detection Control Panel with Thermostats (Sheet 4 of 4).

- j. Tag and disconnect electrical leads to electrical bell.
- k. Remove mounting hardware securing electrical bell to junction box (2).
- l. Remove electrical bell (6).

### **REPAIR**

Repair at this level of maintenance is by replacement of thermostatic switches (1), lever switches (3, 7) and electrical bell (6).

### **ASSEMBLY**

- a. Install electrical bell (6) on junction box (2); secure with mounting hardware.
- b. Connect electrical leads and remove tags.
- c. Install lever switches (7) on surface mounting boxes (5); secure with the mounting hardware.
- d. Connect electrical leads and remove tags.
- e. Install lever switches (3) and replace junction box covers (4); secure with mounting hardware.
- f. Connect electrical leads and remove tags.
- g. Install thermostatic switches (1) on junction boxes (2); secure with mounting hardware.
- h. Connect battery inside fire detection control panel.
- i. Turn circuit breaker 16 ON in EP102. Remove tags.
- j. Notify the bridge that maintenance on the fire detection system is complete.



---

**2-153. Repair Shipboard Alarm Panel. (FIGURE 2-137)**

---

This task covers: a. Disassembly, b. Repair, c. Assembly.

---

**INITIAL SETUP****Tools**

Tool kit, electrician's,  
5180-00-391-1087

**Equipment Condition**

Electrical power to shipboard panel alarm OFF at EP102, circuit breaker 9 tagged "Out of Service - Do Not Operate." (TM 55-1905-223-10)

**Materials/Parts**

Electrical bell P/N 340-4N5  
Thermostatic switch P/N IC/J-105  
Water switch P/N IC/W  
Warning tags, Item 1, Appendix C

---

**WARNING**

Notify the bridge that the shipboard panel alarm will be secured for an extended period of time due to maintenance.

**DISASSEMBLY**

- a. Disconnect electrical cable (2) from electrical bell (4).
- b. Remove hexhead nut (3).
- c. Remove electrical bell (4) from terminal box (1).
- d. Tag and disconnect electrical leads (5) to water switch (6).
- e. Remove mounting hardware and remove water switch (6).
- f. Tag and disconnect electrical leads (9) to thermostatic switch (8).
- g. Remove mounting hardware and remove thermostatic switch (8) from junction box (7).

**REPAIR**

Repair at this level of maintenance is by replacement of electrical bell (4), water switch (6), and thermostatic switch (8).

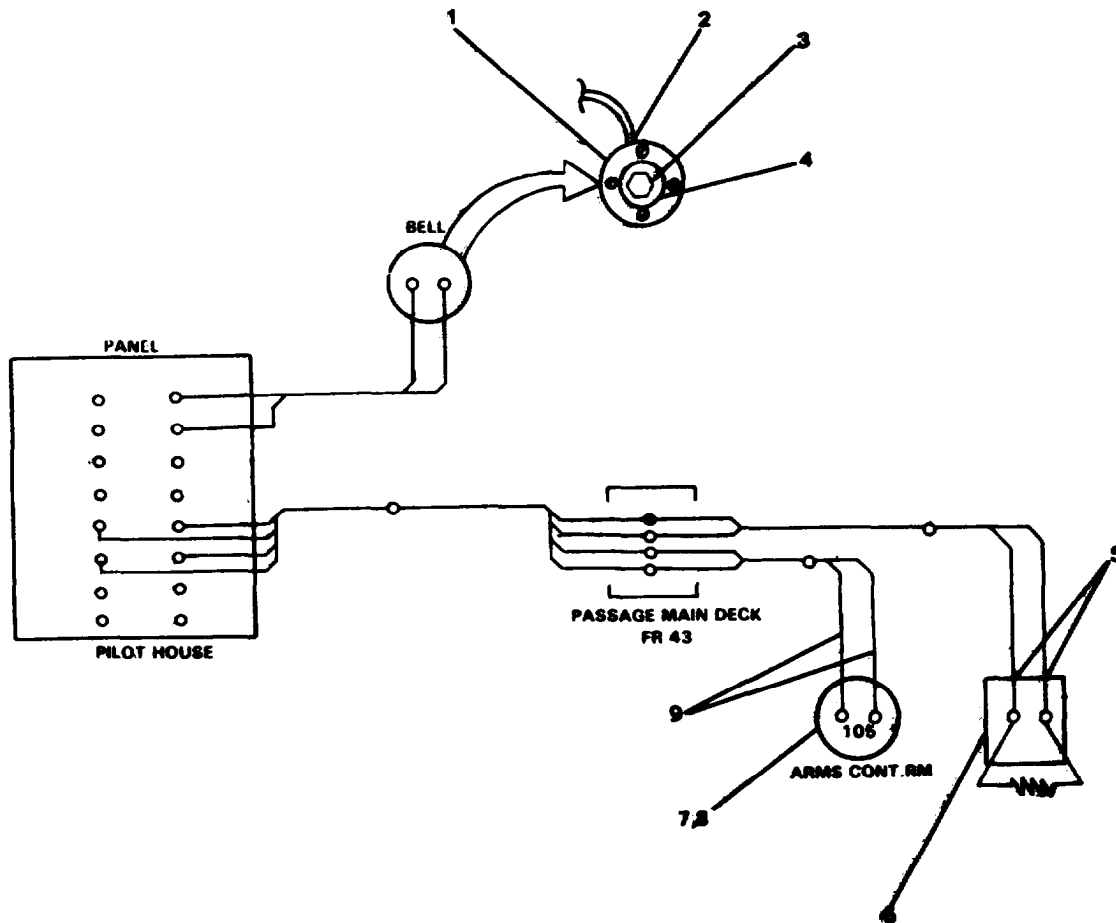


FIGURE 2-137. Shipboard Panel Alarm.

**ASSEMBLY**

- a. Install thermostatic switch (8) in junction box (7). Secure with mounting hardware.
- b. Connect electrical leads (9) to thermostatic switch. Remove tags.
- c. Install water switch (6) and secure with mounting hardware.
- d. Connect electrical leads (5) to water switch. Remove tags.
- e. Install electrical bell (4) on terminal box (1). Secure with hex head nut (3).
- f. Connect electrical cable (2) to electrical bell.
- g. Restore power to shipboard panel alarm at EP102, circuit breaker 9. Remove tag.
- h. Notify the bridge that maintenance on the shipboard panel alarm system is complete.

---

2-154. Replace/Repair Bow Thruster Control System.

---

This task covers: a. Removal, b. Repair, c. Replacement.

---

INITIAL SETUP

Tools

■ Tool kit, electrician's,  
5180-00-391-1087

Materials/Parts

Warning tags, Item 1, Appendix C

---

Equipment Condition

Electrical power to Bow Thruster  
Control system secured and tagged  
"Out of Service - Do Not Operate."  
(TM 55-1905-223-10)

**NOTE**

Repair and replacement of bow thruster control system is by repair and repair of the steering control panel assembly (para. 2-155) and the bow thruster control unit assembly (para. 2-156).

---

**2-155. Replace/Repair Steering Control Panel Assembly. (Figure 2-138)**

---

This task covers: a. Removal, b. Disassembly, c. Repair, d. Assembly, e. Replacement.

---

**INITIAL SETUP****Tools**

Tool kit, electrician's,  
5180-00-391-1087

**Equipment Condition**

Power to bow thruster control system secured and tagged "Out of Service - Do Not Operate." (TM 55-1905-223-10)

**Materials/Parts**

Light lens (green) (2)  
P/N 1054985  
Indicator light (4) P/N 1054978  
Incandescent lamp (4) P/N 1063250  
Light lens (red) (2) P/N 1051399  
Steering switch P/N 1060377  
Push switch (2) P/N 1054979  
Lever switch P/N 1054919  
Lock switch P/N 1051704  
Warning tags, Item 1, Appendix C

---

**REMOVAL**

- a. Remove six round head, screws (2, Sheet 1) from steering control panel (26).
- b. Carefully remove panel from pilothouse control console until electrical leads are exposed.
- c. Tag and disconnect electrical leads to the following: cables C-BT7 (27, Sheet 2), C-BT2 (28), and C-BT1 (29), indicator lights (5, 9, 12, and 25, Sheet 1), gauge (6), push switches (14, 16), steering switch (18), lever switch (20), and lock switch (22).

**DISASSEMBLY**

- a. Unscrew light lens (3) and remove incandescent lamp (4) and indicator light (5).
- b. Unscrew light lens (7) and remove incandescent lamp (8) and indicator light (9).

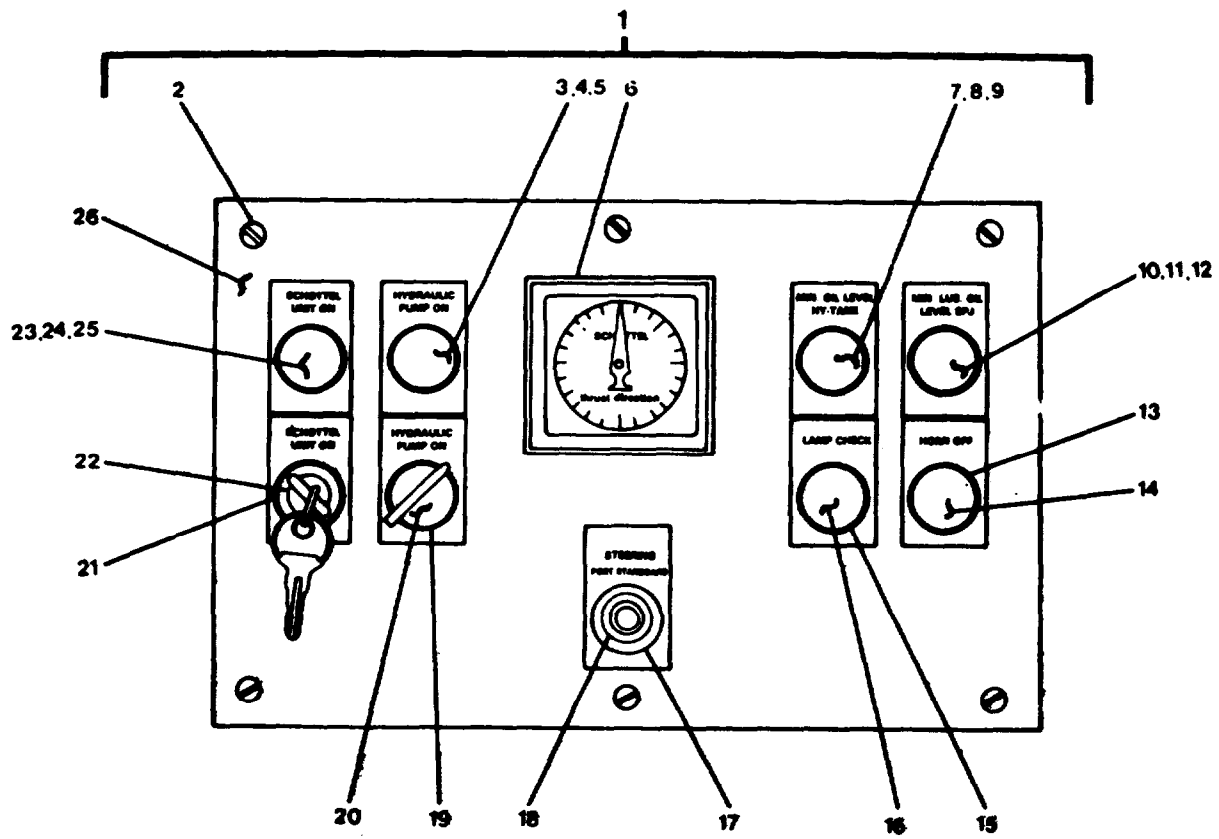


FIGURE 2-138. Steering Control Panel Assembly (Sheet 1 of 2).

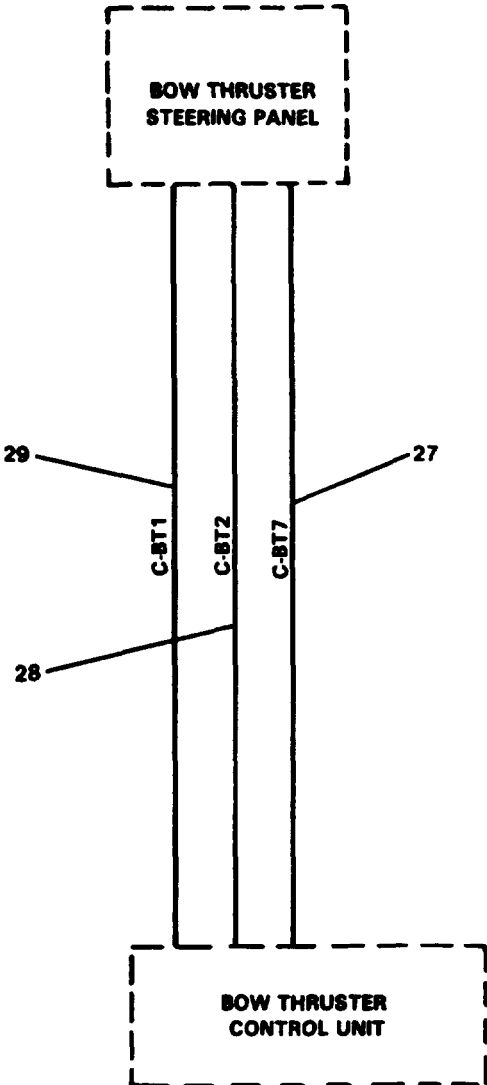


FIGURE 2-138. Steering Control Panel Assembly (Sheet 2 of 2)

- c. Unscrew light lens (10) and remove incandescent lamp (11) and indicator light (12).
- d. Unscrew retaining ring (13) and remove push switch (14).
- e. Unscrew retaining ring (15) and remove push switch (16).
- f. Unscrew retaining ring (17) and remove steering (toggle) switch (18).
- g. Unscrew retaining ring (19) and remove lever switch (20).
- h. Unscrew retaining ring (21) and remove lock switch (22).
- i. Unscrew light lens (23) and remove incandescent lamp (24) and indicator light (25).

### **REPAIR**

Repair at this level of maintenance is by replacement of light lenses (3, 7, 10, and 23), incandescent lamps (4, 8, 11, and 24), indicator lights (5, 9, 12, and 25), push switches (14, 16), steering switch (18), lever switch (20), and lock switch (22).

### **ASSEMBLY**

- a. Install indicator light (25) and incandescent lamp (24); secure with light lens (23).
- b. Install lock switch (22) and secure with retaining ring (21).
- c. Install lever switch (20) and secure with retaining ring (19).
- d. Install steering switch (18) and secure with retaining ring (17).
- e. Install push switch (16) and secure with retaining ring (15).
- f. Install push switch (14) and secure with retaining ring (13).
- g. Install indicator light (12) and incandescent lamp (11). Secure with light lens (10).
- h. Install indicator light (9) and incandescent lamp (8). Secure with light lens (7).
- i. Install indicator light (5) and incandescent lamp (4). Secure with light lens (3).

### **REPLACEMENT**

- a. Connect electrical leads to the following: lock switch (22), lever switch (20), steering switch (18), push switches (14, 16), gauge (6), indicator lights (5, 9, 12, and 25), cables C-BT1 (29), C-BT2 (28), and C-BT7 (27). Remove tags (Sheet 2).



- b. Carefully insert steering control panel assembly (1) in pilothouse control console (Sheet 1).
- c. Secure with six round head screws (2).
- d. Restore power to steering control panel assembly and remove tags.

---

2-156. Replace/Repair Control Unit Assembly (Bowthruster).

---

This task covers: a. Removal, b. Disassembly, c. Repair, d. Assembly,  
e. Replacement.

---

**INITIAL SETUP**

**Tools**

Tool kit, electrician's,  
5180-00-391-1087

**Materials/Parts**

Light lens (red) P/N 1051399  
Indicator light P/N 1054978  
Incandescent lamp P/N 1063250  
Pushbutton P/N 1054976  
Lock switch P/N 1051704  
Buzzer P/N 1032141  
Cartridge fuse P/N 1069895  
Relay P/N 1026045  
Rotary switch P/N M522STK  
Transmitter indicator P/N 4081468  
Terminal box P/N 1011586  
Level switch P/N 1012099  
Rotary switch P/N S2JRM3B2  
Lever switch P/N 10250T3011  
Push switch P/N 10250T2  
Warning tags, Item 1, Appendix C  
Utility pail, Item 13, Appendix C  
Wiping rags, Item 14, Appendix C

**Equipment Condition**

Electrical power to bowthruster control system secured and tagged "Out of Service - Do Not Operate." (TM 55-1905-223-10)

---

**REMOVAL**

- a. Remove Rotary Switch. (FIGURE 2-139)

**WARNING**

To avoid electrical shock, make sure power to switch is secured and tagged "Out of Service - Do Not Operate."

- (1) Remove four retaining screws (1) securing cover (2).
- (2) Remove cover, tag and disconnect electrical leads to rotary switch (4).
- (3) Remove hex head nut (3) securing rotary switch to cover.

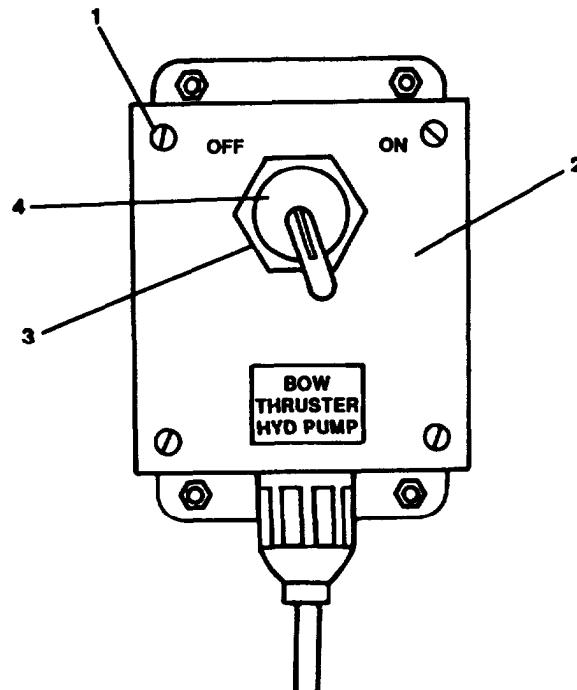


FIGURE 2-139. Rotary Switch. Removal.

- (4) Remove rotary switch.
- b. Remove Level Switch. (Bowthruster Engine) (FIGURE 2-140)
  - (1) Unscrew connector (2) and remove electrical cable (1).
  - (2) Unscrew hex head nut (3) and remove level switch (4).

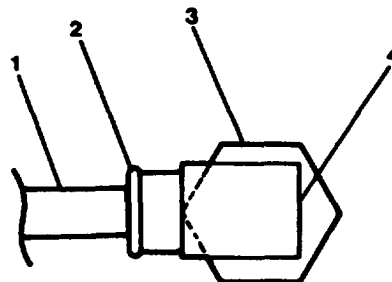


FIGURE 2-140. Level Switch. Removal.

c. Removal Terminal Box. (Bowthruster Engine) (FIGURE 2-141)

- (1) Tag and disconnect electrical cables at connections (4, 5, and 7).
- (2) Remove four hex head nuts (1) from mounting studs (2).
- (3) Remove terminal box (3) from mounting bracket (6).

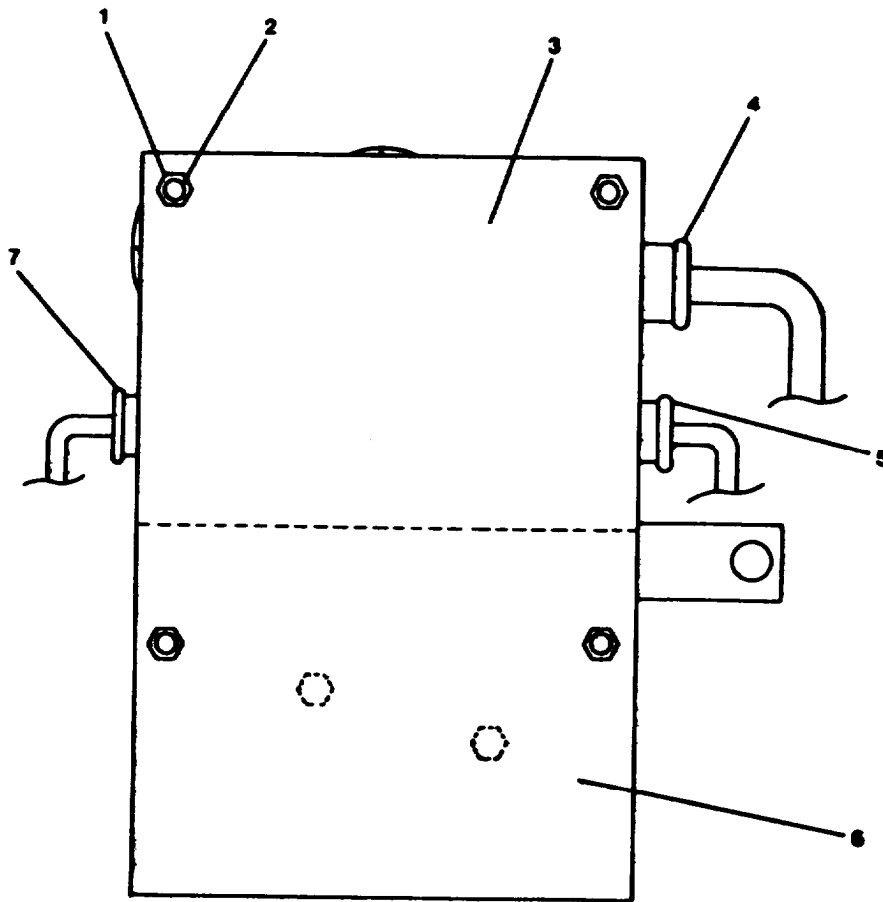


FIGURE 2-141. Terminal Box.

d. Remove Transmitter Indicator. (Bowthruster Engine) (FIGURE 2-142)

- (1) Remove cover (7). Disconnect electrical cables. Remove cables at connection (2).
- (2) Remove four hex head nuts (3) from mounting studs (4).
- (3) Lift transmitter indicator (1) off of bracket (5) and shaft (6).

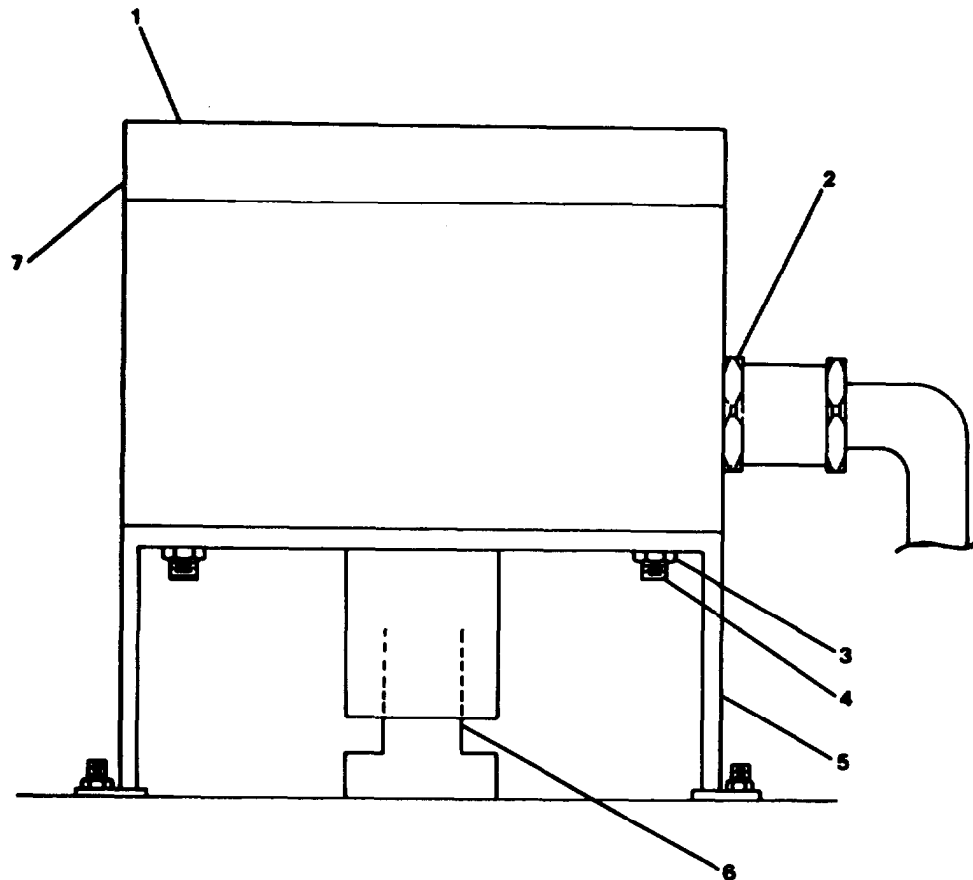


FIGURE 2-142. Transmitter Indicator.

- e. **Remove Lever Switch.** (Located on Waterjet power pack) (FIGURE 2-143)
- (1) Place utility pail under hydraulic lines at connections (2, 3).
  - (2) Disconnect hydraulic lines. Cap or plug lines.
  - (3) Remove four capscrews (4).
  - (4) Remove lever switch (1).
  - (5) Wipe up hydraulic oil leakages.

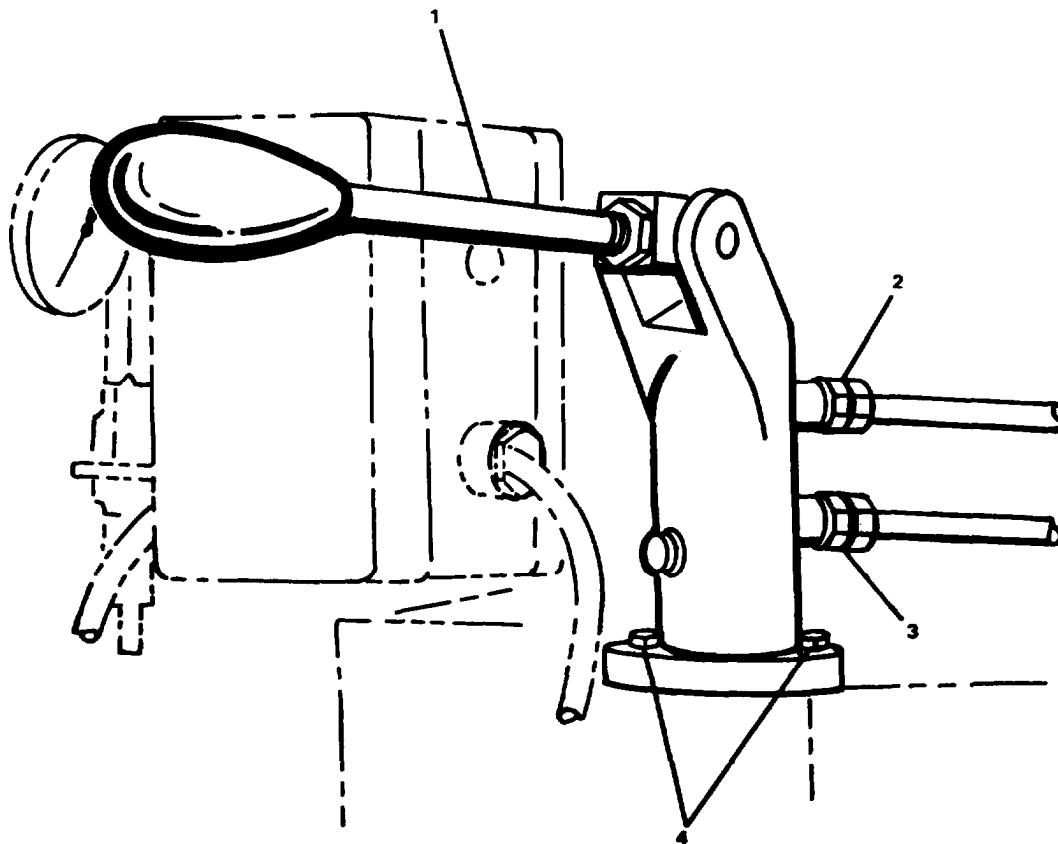


FIGURE 2-143. Lever Switch.

f. Remove Push Switch. (FIGURE 2-144)

- (1) Tag and disconnect electrical leads to push switch.
- (2) Loosen set screw (2) and remove knob (1).
- (3) Remove hex head nut (3).
- (4) Remove push switch (5) from pilothouse control console (4).

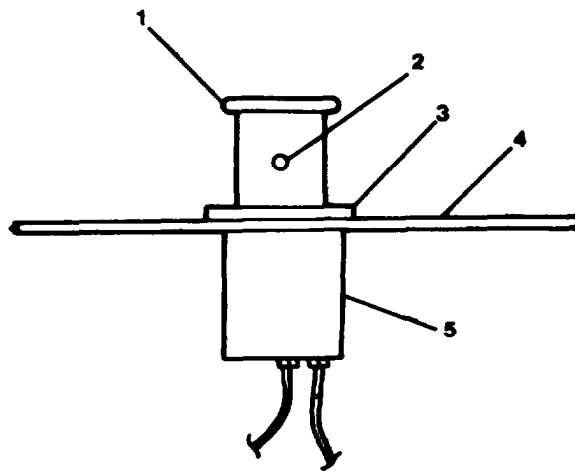


FIGURE 2-144. Push Switch.

- g. Remove Rotary Switch. (Starboard Bulkhead) (FIGURE 2-145)
- (1) Remove round head screw (4) and lever (3).
  - (2) Remove four screws (7) and cover (8).
  - (3) Tag and disconnect electrical leads (6) to rotary switch.
  - (4) Remove four round head screws (2) and rotary switch cover (1).
  - (5) Remove rotary switch (5).

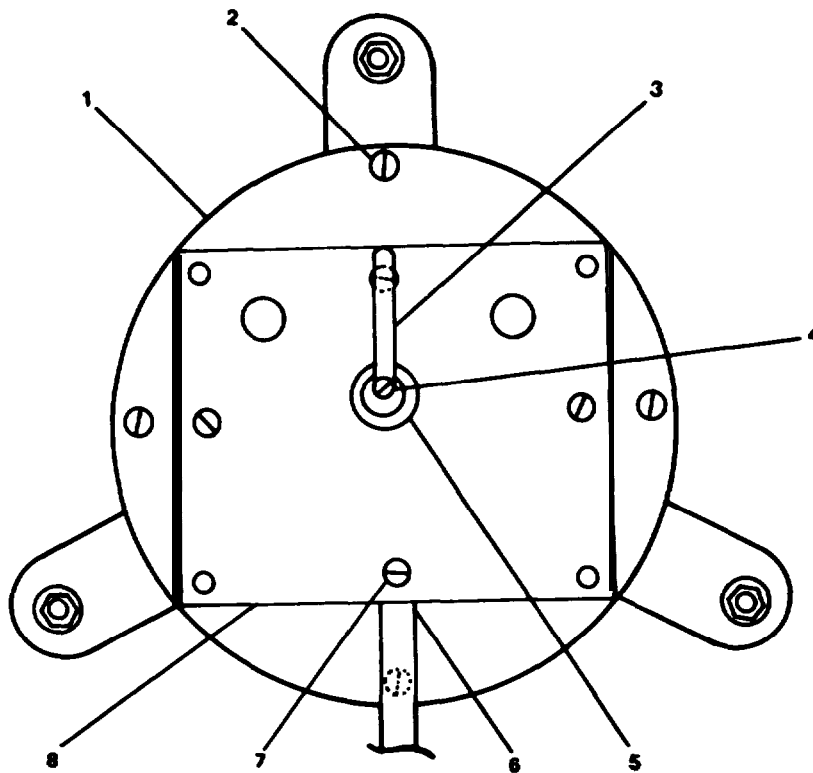


FIGURE 2-145. Rotary Switch.

DISASSEMBLY (FIGURE 2-146)

- a. Remove key (4) from side of control unit and insert in keyhole (5) to unlock nut.
- b. Swing door (9) to the left to open.
- c. Tag and disconnect electrical leads to the following: lamp check push switch (3), leads (13, 27), horn off push switch (12), leads (15), buzzer (10), leads (24, 25), collective alarm indicator (8), leads (23), relays (21), and leads (22).

- d. Unscrew retaining ring (2) and remove two screws (14).
- e. Remove lamp check push switch (3).
- f. Unscrew retaining ring (11) and remove two screws (16).
- g. Remove horn off push switch (12).
- h. Unscrew collective alarm lens (6). Remove incandescent lamp (7).
- i. Remove two screws (26) and remove collective alarm indicator light (8).
- j. Unscrew buzzer (10) and remove.
- k. Unscrew two hexagon head screws (17) and remove cartridge fuse cover plate (18).
- l. Remove cartridge fuses (19).
- m. Remove capscrews (20) and remove relays (21).

### **REPAIR**

Repair at this level of maintenance is by replacement of rotary switch (4, FIGURE 2-145), level switch (4, FIGURE 2-140), terminal box (3, FIGURE 2-141), transmitter indicator (1, FIGURE 2-142), lever switch (1, FIGURE 2-143), push switch (5, FIGURE 2-144), rotary switch (1, FIGURE 2-145), push switches (3, 12, FIGURE 2-144), buzzer (10), lens (6), incandescent lamp (7), indicator light (8), cartridge fuses (19), and relays (21).

### **ASSEMBLY**

- a. Install relays (21, FIGURE 2-146) and secure with capscrews (20).
- b. Install cartridge fuses (19), replace cover plate (18), and secure with two hexagon head screws (17).
- c. Screw buzzer (10) into slot in door.
- d. Install collective alarm indicator (8) and secure with two screws (26).
- e. Install incandescent lamp (7) in indicator (8) and replace collective alarm lens (6).
- f. Install horn off push switch (12).
- g. Secure with two screws (16) and replace retaining ring (11).
- h. Install lamp check push switch (3).
- i. Secure with two screws (14) and replace retaining ring (2).



- j. Connect electrical leads to the following: relays (21 and leads 22), collective alarm indicator (8 and lead 23), buzzer (10 and leads 24, 25), horn off push switch (12 and leads 15) and lamp check push switch (3 and leads 13, 27).
- k. Close door.
- l. Insert key (4) in keyhole (5) and lock unit. Replace key on side of control unit.

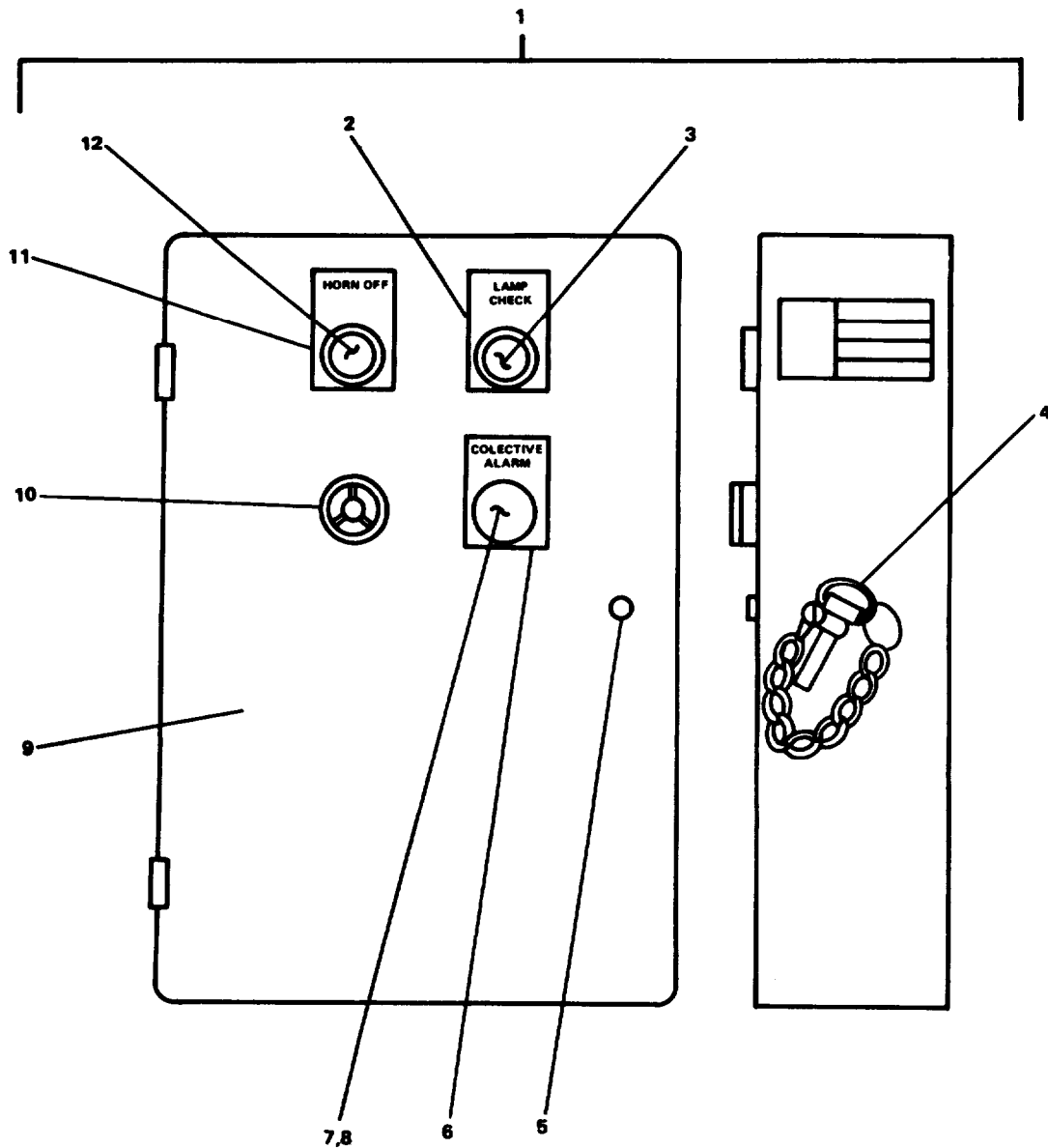


FIGURE 2-146. Control Unit Assembly, Bowthruster (Sheet 1 of 2).

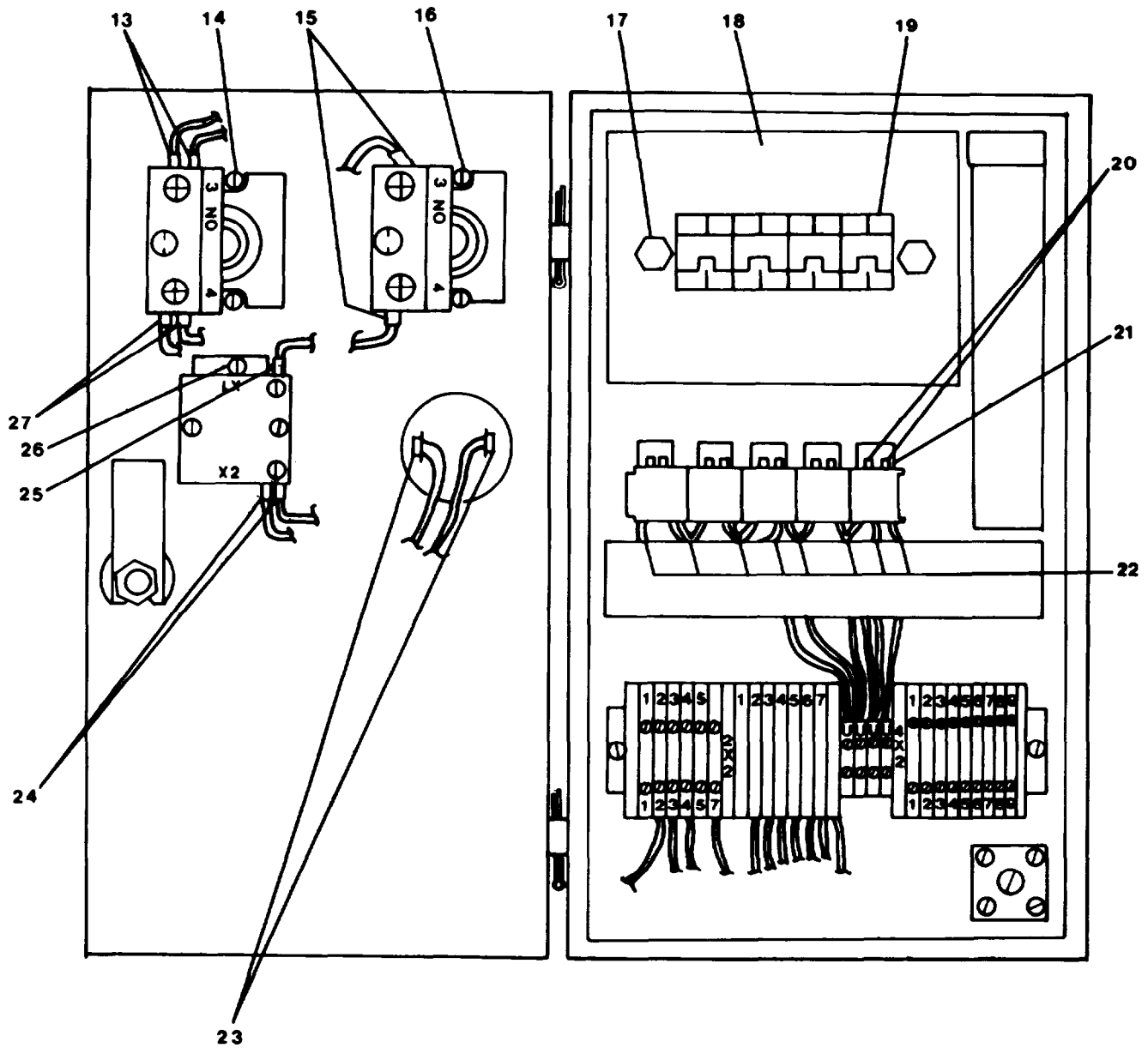


FIGURE 2-146. Control Unit Assembly. Bowthruster (Sheet 2 of 2).

**REPLACEMENT**a. Replace Rotary Switch. (FIGURE 2-145)

- (1) Install rotary switch (5) through slot in rotary switch cover (1).
- (2) Replace cover and secure with four round head screws (2).
- (3) Connect electrical leads (6) and remove tags.
- (4) Replace cover (8) and secure with four screws (7).
- (5) Install lever (3) and secure with round head screws (4).

b. Replace Bush Switch. (FIGURE 2-144)

- (1) Install push switch (5) in slot in pilothouse control console (4).
- (2) Secure with hex head nut (3).
- (3) Install knob (1) on switch and secure set screw (2).
- (4) Connect electrical leads and remove tags.

c. Replace Lever Switch. (FIGURE 2-143)

- (1) Install lever switch (1) and secure with four capscrews (4).
- (2) Remove caps or plug and connect hydraulic lines at connections (2, 3).

d. Replace Transmitter Indicator.

- (1) Seat indicator (1) on shaft (6).
- (2) Secure indicator to bracket (5) by screwing four hex head nuts (3) onto mounting studs (4).
- (3) Connect electrical cable at connection (2).

e. Replace Terminal Box.

- (1) Install terminal box (3) on mounting bracket (6).
- (2) Secure terminal box to bracket by screwing four hex head nuts (1) onto mounting studs (2).
- (3) Connect electrical cables at connections (4, 5, and 7). Remove tags.

f. Replace Level Switch.

- (1) Install level switch (4) and secure with hex head nut (3).
- (2) Connect electrical cable (1) at connection (2).

g. Replace Rotary Switch.

(1) Position rotary switch (4) in cover (2).

(2) Secure with hex head nut (3).

(3) Connect electrical leads to rotary switch. Remove tags.

(4) Secure cover (2) to box with four retaining screws (1).

h. Restore electrical power to bowthruster and control panel assembly. Remove tags.

i. Restore hydraulic power to bowthruster. Remove tags.

MAINTENANCE OF ELECTRICAL SYSTEM
----------------------------------

---

2-157. Replace/Repair Power Distribution (240V).

---

This task covers: a. Removal, b. Repair, c. Replacement.

---

INITIAL SETUP

Tools

Tool kit, electrician's,  
5180-00-391-1087

Equipment Condition

Disconnect input power to the panel(s)  
being replaced/repared and tag "Out  
of Service - Do Not Operate."

Materials/Parts

Warning tags, Item 1, Appendix C

---

Replacement and repair of 240V power distribution is by replacement/repair of the components in the power distribution system. Refer to paragraphs 2-158 through 2-176.

---

2-158. Replace/Repair Shore Power Supply Assembly. (FIGURE 2-147).

---

This task covers: a. Removal, b. Repair, c. Replacement.

---

### INITIAL SETUP

#### Tools

Tool kit, electrician's,  
5180-00-391-1087

#### Equipment Condition

Disconnect input power to the assembly being replaced/repaired and tag "Out of Service - Do Not Operate."  
TM 55-1905-223-10.

#### Materials/Parts

Warning tags, Item 1, Appendix C

---

### REMOVAL

- a. Tag and disconnect shore power cable assembly (7) from shore power supply terminal box (8).
- b. Tag and disconnect electrical power cables (PO405 B) (T-200) (9) from shore power supply terminal box (8) and shore power transformer (4).
- c. Tag and disconnect electrical power cables (PO405 A) (T-200) (5) from ship service switchboard and shore power transformer (4).
- d. Tag and disconnect electrical cables (P0205) (T-200) (6) from ship service switchboard and shore power transformer (4).
- e. Tag and disconnect electrical power cables (P0204) (D-4) (2) from indicator light and ship service switchboard.
- f. Tag and disconnect electrical power cables (P0201) (T-200) (3) from ship service switchboard.
- g. Tag and disconnect electrical power cables (PO202 A) (M-14) (10) from ship service diesel generator No. 1 and ship service switchboard (Sheet 2).
- h. Tag and disconnect electrical power cables (P0202) (T-300) (11) from ship service diesel generator No. 1 and ship service switchboard.
- i. Tag and disconnect electrical power cable (PO202 GOV) (F-4) (12) from ship service switchboard.
- j. Tag and disconnect electrical power cable (PO202 HTR) (D-4) (13) from ship service diesel generator No. 1 and ship service switchboard.

- k. Tag and disconnect electrical power cable (PO203 A) (M-14) (14) from ship service diesel generator No. 2 and ship service switchboard.
- l. Tag and disconnect electrical power cable (PO203) (T-300) (15) from ship service diesel generator No. 2 and ship service switchboard.
- m. Tag and disconnect electrical power cable (PO203 GOV) (F-4) (16) from ship service diesel generator No. 2 and ship service switchboard.
- n. Tag and disconnect electrical power cable (PO203 HTR) (D-4) (17) from ship service diesel generator No. 2 and ship service switchboard.

### **REPAIR**

Repair of the shore power supply assembly is by replacement of electrical power cables.

### **REPLACEMENT**

- a. Remove tag and connect electrical power cable (PO203 HTR) (D-4) (17) to ship service diesel generator No. 2 and ship service switchboard.
- b. Remove tag and connect electrical power cable (PO203 GOV) (F-4) (16) to ship service diesel generator No. 2 and ship service switchboard.
- c. Remove tag and connect electrical power cable (PO203) (T-300) (15) to ship service diesel generator No. 2 and ship service switchboard.
- d. Remove tag and connect electrical power cable (P0203A) (M-14) (14) to ship service diesel generator No. 2 and ship service switchboard.
- e. Remove tag and connect electrical power cable (PO202 HTR) (D-4) (13) to ship service diesel generator No. 1 and ship service switchboard.
- f. Remove tag and connect electrical power cable (PO202 GOV) (F-4) (12) to ship service diesel generator No. 1 and ship service switchboard.
- g. Remove tag and connect electrical power cable (PO202) (T-300) (11) to ship service diesel generator No. 1 and ship service switchboard.
- h. Remove tag and connect electrical power cable (P0202A) (M-14) (10) to ship service diesel generator No. 1 and ship service switchboard.
- i. Remove tag and connect electrical power cable (PO201) (T-200) (3) to ship service switchboard.
- j. Remove tag and connect electrical power cable (PO204) (D-4) (2) to indicator light and ship service switchboard.
- k. Remove tag and connect electrical power cables (PO205) (T-200) (6) to ship service switchboard and shore power transformer (4).
- l. Remove tag and connect electrical power cables (P0205A) (T-200) (5) to ship service switchboard and shore power transformer (4).

- m. Remove tag and connect electrical power cable (P0405B) (T-200) (9) to shore power supply terminal box (8) and shore power transformer (4).
- n. Remove tag and connect shore power cable assembly (7) to shore power supply terminal box (8).
- o. Remove tags and restore power to panel(s).

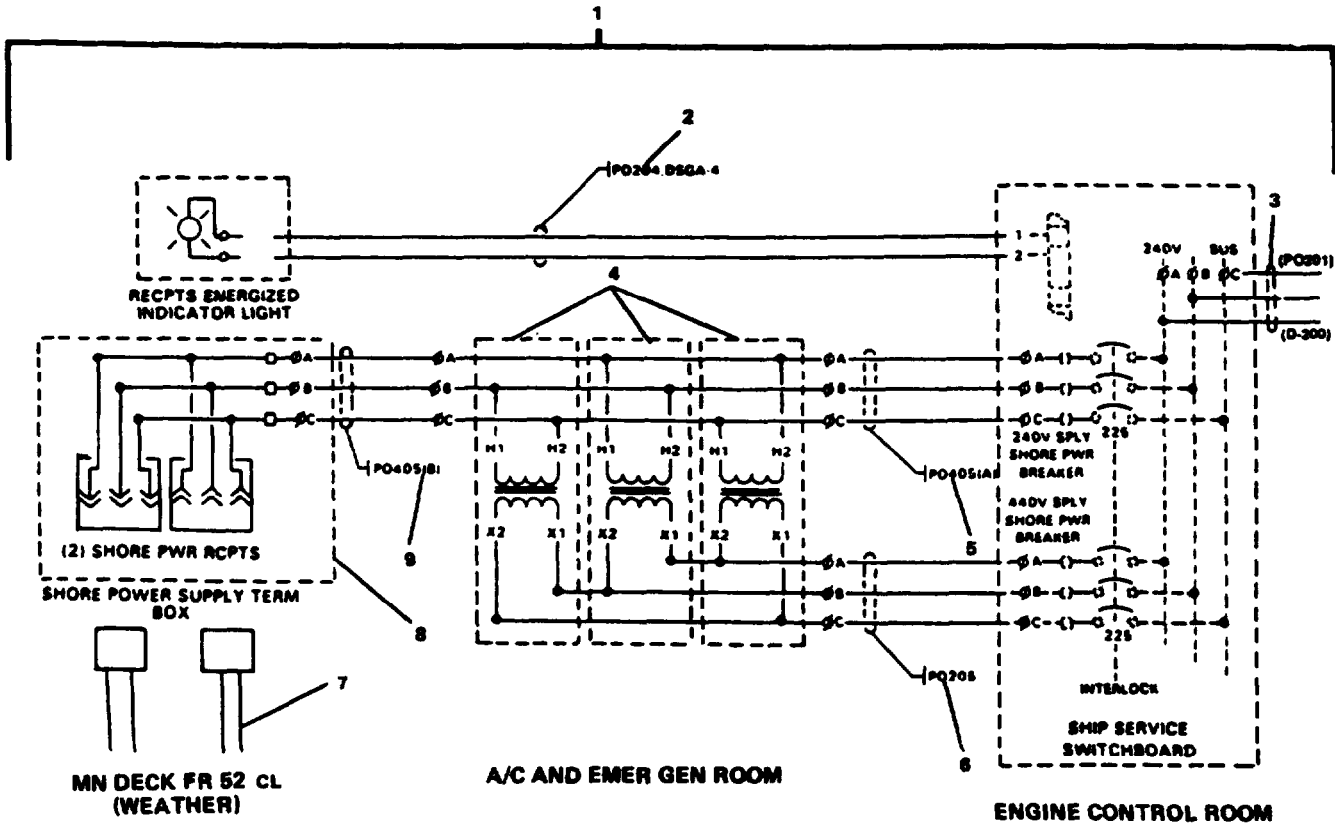


FIGURE 2-147. Shore Power Supply Assembly (Sheet 1 of 2).



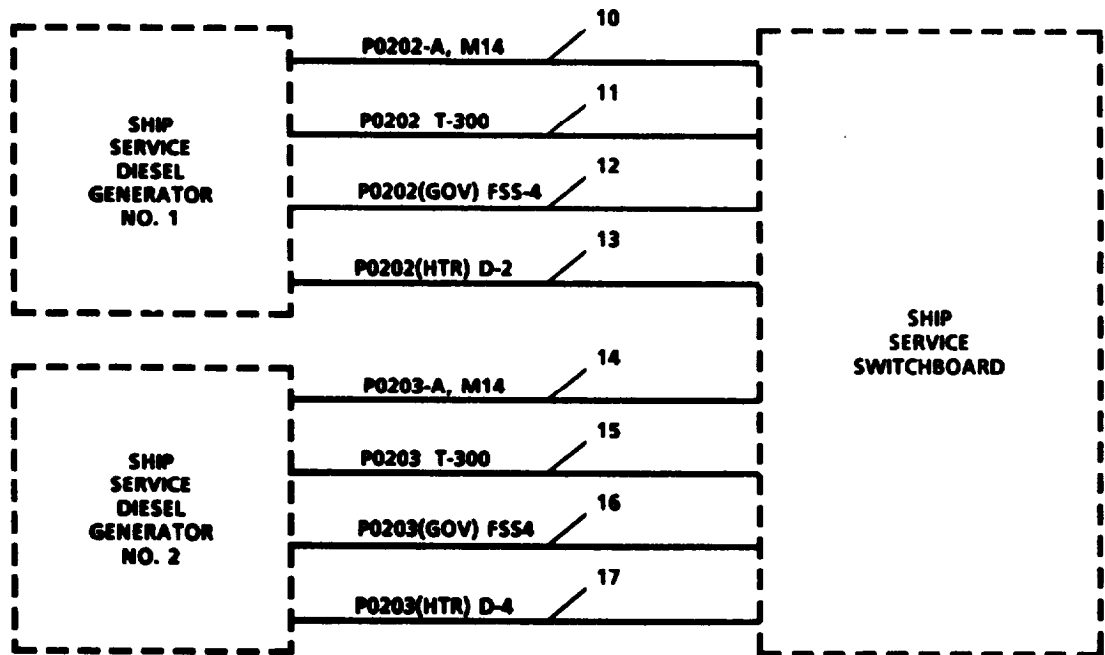


FIGURE 2-147. Shore Power Supply Assembly (Sheet 2 of 2).

2-159. Replace/Repair Power Distribution Panel P201. (FIGURE 2-148)

---

This task covers: a. Removal, b. Repair, c. Replacement.

---

INITIAL SETUP

Tools

Tool kit, electrician's,  
5180-00-391-1087

Equipment Condition

Main switchboard FWD HEADER POWER PANEL  
P201 175AT circuit breaker OFF and  
tagged "Out of Service - Do Not  
Operate." TM 55-1905-223-10.

Materials/Parts

Circuit breaker P/N Q330HM  
Circuit breaker P/N Q315HM  
Circuit breaker P/N Q340HM  
Warning tag, Item 1, Appendix C

---

WARNING

Death, serious injury, or equipment damage can result from contact with live electrical circuits. Before beginning work on this or any other electrical equipment, turn power and control voltage circuit breakers OFF and tag "Out of Service - Do Not Operate."

REMOVAL

- a. Remove door assembly.
  - (1) Open door (8, sheet 1).
  - (2) Remove four mounting bolts (7).
  - (3) Remove panel cover (1) and door assembly (8).
  - (4) Remove machine screws (5), springs (4), latches (6), push on nuts (2), and spring washers (3).
  - (5) Remove panel insert (9).
  
- b. Remove circuit breakers.
  - (1) Tag associated breaker wiring (16, sheet 2).
  - (2) Loosen wire mounting screw on circuit breaker (15) and remove wire (16) from circuit breaker.
  - (3) Grasp circuit breaker (15) on end nearest center of panel and pull out to remove circuit breaker from panel.

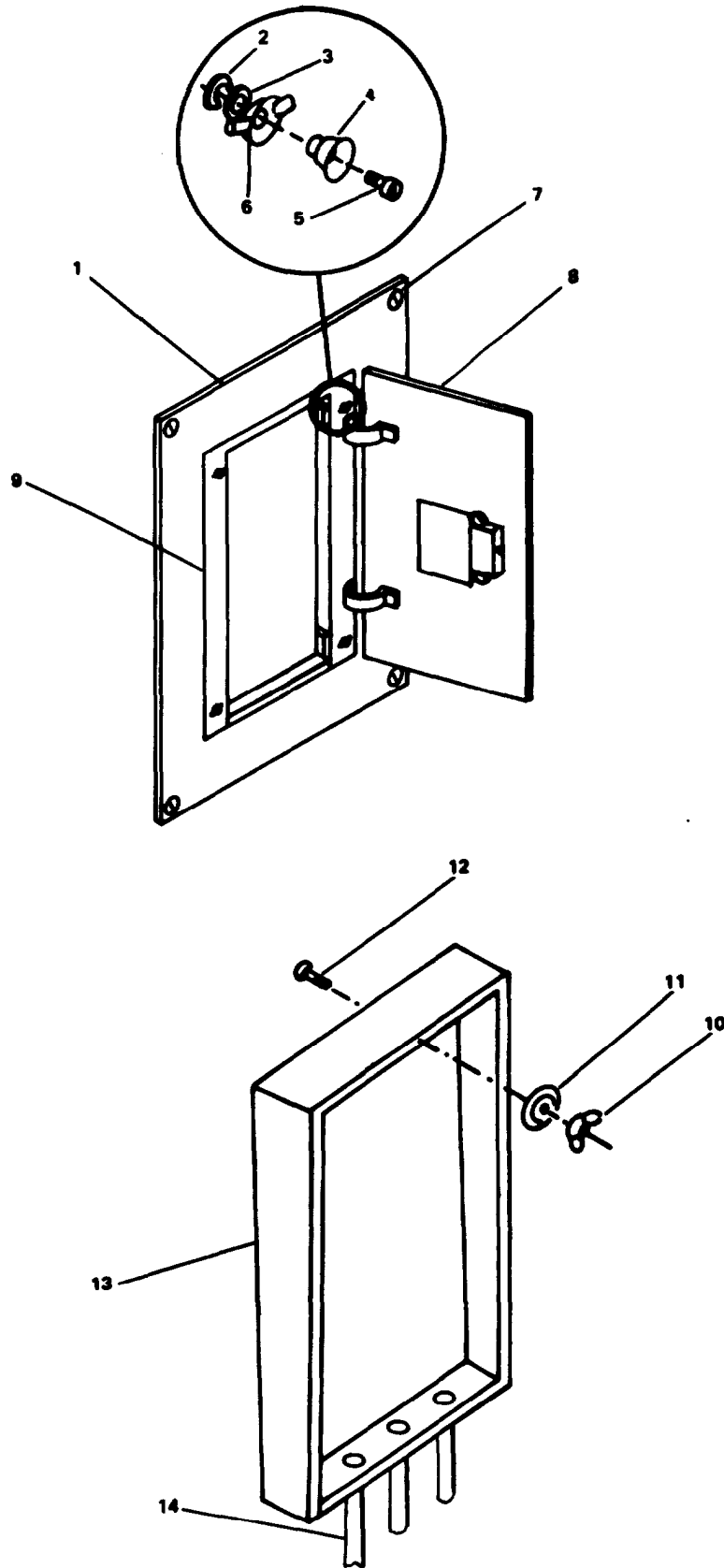
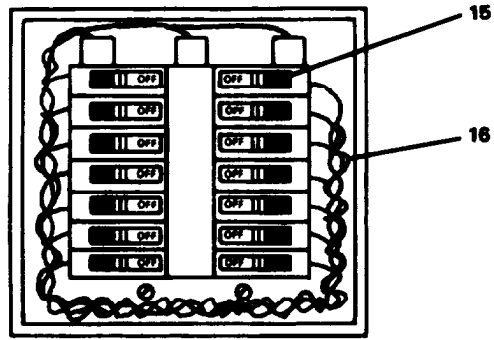


FIGURE 2-148. Power Distribution Panel Removal (Sheet 1 of 2).



8079

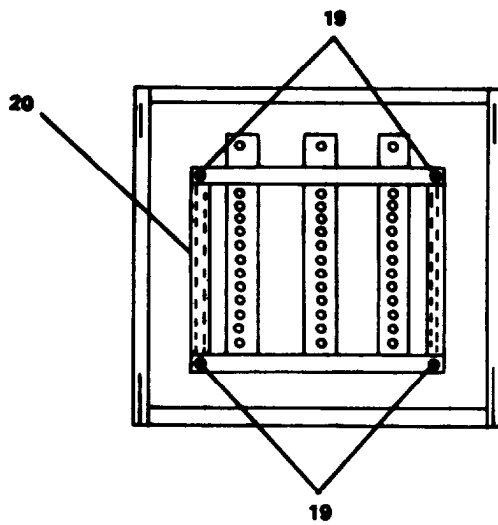
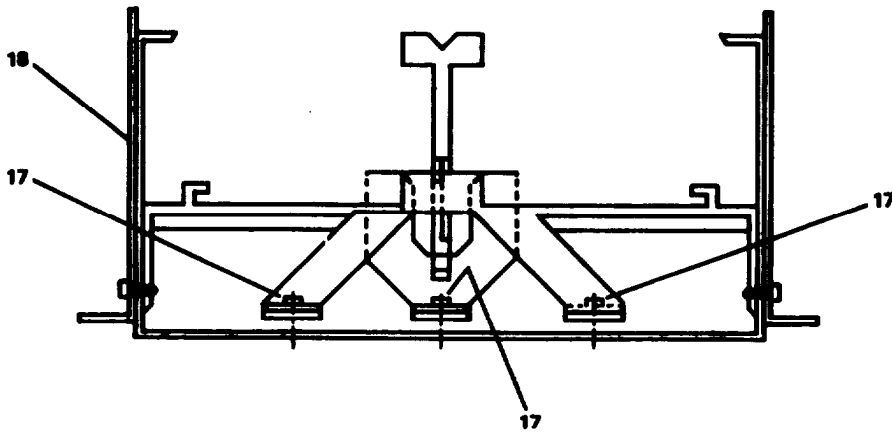


FIGURE 2-148. Power Distribution Panel Remove (Sheet 2 of 2).

- c. Remove breaker plug in unit.
  - (1) Remove machine screws (17).
  - (2) Remove breaker plug in unit (18).
- d. Remove main interior lug.
  - (1) Remove attaching screws (19).
  - (2) Remove main interior lug (20).
- e. Remove power distribution panel.
  - (1) Tag and disconnect electrical power cables (14, sheet 1).
  - (2) Remove four wing nuts (10), star nuts (11), and machine screws (12).
  - (3) Remove power distribution panel (13).

### **REPAIR**

Repair of power distribution panel is by replacement of circuit breakers. Repair of door assembly, breaker plug in unit, and main interior lug is by replacement of the components.

### **REPLACEMENT**

- a. Replace power distribution panel.
  - (1) Position power distribution panel (13, sheet 1).
  - (2) Secure with four machine screws (12), star nuts (11) and wing nuts (10).
  - (3) Remove tags and connect electrical cables (14).
- b. Replace main interior lug.
  - (1) Install main interior lug (20, sheet 2).
  - (2) Secure with attaching screws (19).
- c. Replace breaker plug in unit.
  - (1) Install breaker plug in unit (18).
  - (2) Secure with machine screws (17).
- d. Replace circuit breakers.
  - (1) Push circuit breaker (15) on end nearest center of panel to lock circuit breaker in panel.
  - (2) Attach wire (16) to circuit breaker. Tighten wire mounting screw on circuit breaker. Remove tag.
- a. Replace door assembly.
  - (1) Install panel insert (9, sheet 1).
  - (2) Secure with spring washers (3), push on nuts (2), latches (6), springs (4) and machine screws (5).
  - (3) Install panel cover (1), and door assembly (8).
  - (4) Secure with mounting bolts (7).

TM 55-1905-223-24-18-1

(5) Close door (8).

f. Turn power on, remove tags.

---

2-160. Replace/Repair Power Distribution Panel, Galley P202.

---

This task covers: a. Removal, b. Repair, c. Replacement.

---

### INITIAL SETUP

#### Tools

Tool kit, electrician's,  
5180-00-391-1087

#### Equipment Condition

Main switchboard GALLEY POWER PANEL  
P202 250RT circuit breaker OFF and  
tagged "Out of Service - Do Not  
Operate." TM 55-1905-223-10.

#### Materials/Parts

Circuit breaker P/N 360H  
Circuit breaker P/N 325H  
Circuit breaker P/N Q315H  
Circuit breaker P/N Q330H  
Circuit breaker P/N Q340H  
Warning tag, Item 1, Appendix C

---

### WARNING

Death, serious injury, or equipment damage can result from contact with live electrical circuits. Before beginning work on this, or any other electrical equipment, turn power and control voltage circuit breakers OFF and tag "Out of Service - Do Not Operate."

Refer to the procedures in paragraph 2-159 to replace and repair the power distribution panel, door assembly, plug in breaker unit, and main interior lug.

2-161. Replace/Repair Power Distribution Panel P203.

---

This task covers: a. Removal, b. Repair, c. Replacement

---

**INITIAL SETUP**

**Tools**

Tool kit, electrician's,  
5180-00-392-2895

**Materials/Parts**

Circuit breaker P/N Q315HM  
Circuit breaker P/N Q320HM  
Circuit breaker P/N Q345HM  
Circuit breaker P/N Q330HM  
Warning tag, Item 1, Appendix C

**Equipment Condition**

Main switchboard MCHRY SPACES HTR PWR  
PNL P203 150AT circuit breaker OFF  
and tagged "Out of Service - Do Not  
Operate." TM 55-1905-223-10.

---

**WARNING**

Death, serious injury, or equipment damage can result from contact with live electrical circuits. Before beginning work on this, or any other electrical equipment, turn power and control voltage circuit breakers OFF and tag "Out of Service - Do Not Operate."

Refer to the procedures in paragraph 2-159 to replace and repair the power distribution panel, door assembly, plug in breaker unit, and main interior lug.



2-162. Replace/Repair Power Distribution Panel P204.

This task covers: a. Removal, b. Repair, c. Replacement.

INITIAL SETUP

Tools

Tool kit, electrician's,  
5180-00-391-1087

Equipment Condition

Main switchboard MISC MCHRY POWER  
PANEL P204 60AT circuit breaker  
OFF and tagged "Out of Service - Do  
Not Operate." TM 55-1905-223-10.

Materials/Parts

Circuit breaker P/N Q315HM  
Warning tag, Item 1, Appendix C

WARNING

Death, serious injury, or equipment damage can result from contact with live electrical circuits. Before beginning work on this, or any other electrical equipment, turn power and control voltage circuit breakers OFF and tag "Out of Service - Do Not Operate."

Refer to the procedures in paragraph 2-159 to replace and repair the power distribution panel, door assembly, plug in breaker unit, and main interior lug.

---

2-163. Repair Auxiliary Machinery Motor Control Center Power Distribution.  
(FIGURE 2-149).

---

This task covers: a. Removal, b. Replacement.

---

### INITIAL SETUP

#### Tools

Tool kit, electrician's,  
5180-00-391-1087

#### Equipment Condition

Main switchboard AUX MCHRY MCC P205  
75AT circuit breaker OFF and tagged  
"Out of Service - Do Not Operate"  
(TM 55-1905-223-10)

#### Materials/Parts

Push switch P/N 10250H671  
Push switch P/N 10250H658  
Warning tag, Item 1, Appendix C

---

### WARNING

Death, serious injury, or equipment damage can result from contact with live electrical circuits. Before beginning work on this, or any other electrical equipment, turn power and control voltage circuit breakers OFF and tag "Out of Service - Do Not Operate."

### NOTE

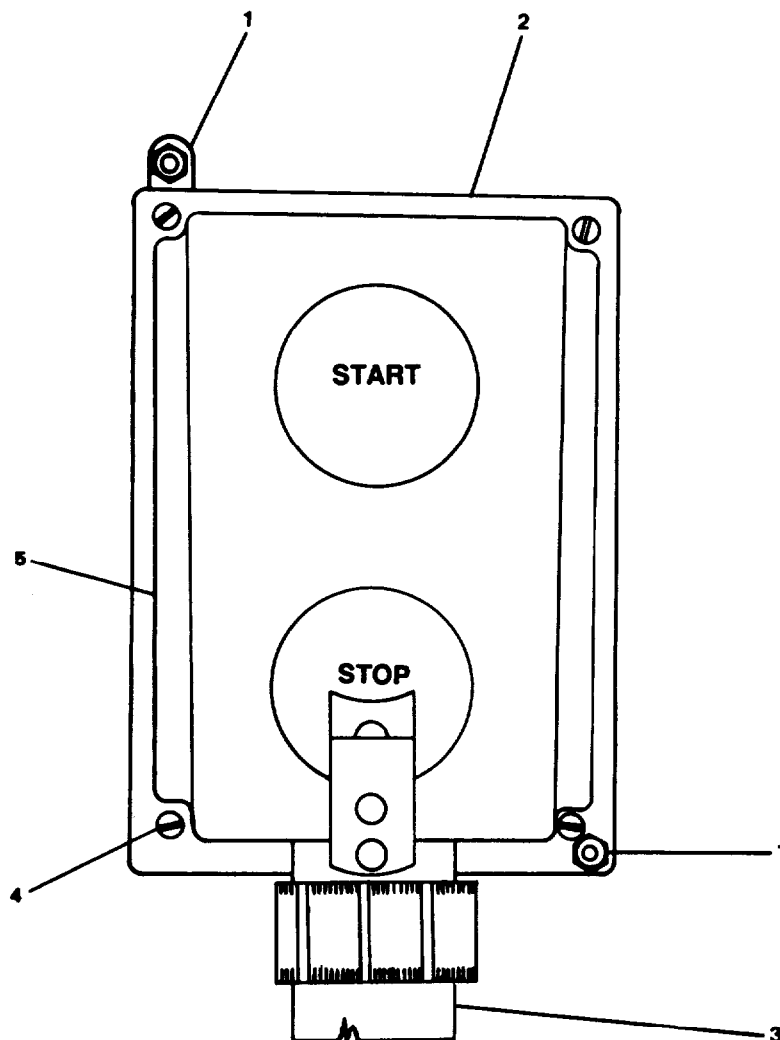
Repair of motor control center power distribution is by replacement of push switches supplied by the motor control center. Refer to TM 55-1905-223-10 for location of push switches.

### REMOVAL

- a. Remove four cover screws (4) and cover (5). Tag and disconnect wiring to switch.
- b. Disconnect wiring cable (3).
- c. Remove two mounting screws/nuts (1).
- d. Remove push switch (2).

REPLACEMENT

- a. Position push switch (2).
- b. Secure with two mounting screws/nuts (1).
- c. Connect wiring cable (3).
- d. Connect wiring to switch. Install cover (5) and four cover screws (4).
- e. Turn main switchboard circuit breaker ON (TM 55-1905-223-10). Remove tag.

FIGURE 2-149. Push Switch. Typical.

2-164. Repair Forward Deck Machinery Motor Control Center Power Distribution.

---

This task covers: a. Removal, b. Replacement.

---

INITIAL SETUP

Tools

Tool kit, electrician's,  
5180-00-391-1087

Materials/Parts

Push switch P/N 10250H671  
Warning tag, Item 1, Appendix C

Equipment Condition

Main switchboard FWD MCHRY MCC P206  
200AT circuit breaker OFF and tagged  
"Out of Service - Do Not Operate" (TM  
55-1905-223-10):

---

WARNING

Death, serious injury, or equipment damage can result from contact with live electrical circuits. Before beginning work on this, or any other electrical equipment, turn power and control voltage circuit breakers OFF and tag "Out of Service - Do Not Operate."

NOTE

Repair of motor control center power distribution is by replacement of push switches supplied by the motor control center. Refer to TM 55-1905-223-10 for location of push switches.

Refer to the procedures in paragraph 2-163 to replace push switches.

---

2-165. Repair Fire Pump Number Two Power Distribution.

---

This task covers: a. Removal, b. Replacement.

---

### INITIAL SETUP

#### Tools

Tool kit, electrician's,  
5180-00-391-1087

#### Materials/Parts

Push switch P/N 10250H671  
Warning tag, Item 1, Appendix C

#### Equipment Condition

Main switchboard FIRE PUMP 2 P207 100AT  
circuit breaker OFF and tagged "Out  
of Service - Do Not Operate" (TM 55-  
1905-223-10):

---

### WARNING

Death, serious injury, or equipment damage can result from contact with live electrical circuits. Before beginning work on this, or any other electrical equipment, turn power and control voltage circuit breakers OFF and tag "Out of Service - Do Not Operate."

### NOTE

Repair of fire pump number two power distribution is by replacement of push switches. Refer to TM 55-1905-223-10 for location of push switches.

Refer to the procedures in paragraph 2-163 to replace push switches.

---

2-166. Repair Engine Room Vent Motor Control Center Power Distribution.

---

This task covers: a. Removal, b. Replacement.

---

INITIAL SETUP

Tools

Tool kit, electrician's,  
5180-00-391-1087

Materials/Parts

Push switch P/N 10250H671  
Push switch P/N 10250H4241  
Warning tag, Item 1, Appendix C

Equipment Condition

Main switchboard ENG ROOM VENTMCC P210  
200AT 125AT circuit breaker OFF and  
tagged "Out of Service - Do Not  
Operate" (TM 55-1905-223-10):

---

WARNING

Death, serious injury, or equipment damage can result from contact with live electrical circuits. Before beginning work on this, or any other electrical equipment, turn power and control voltage circuit breakers OFF and tag "Out of Service - Do Not Operate."

NOTE

Repair of motor control center power distribution is by replacement of push switches supplied by the motor control center. Refer to TM 55-1905-223-10 for location of push switches.

Refer to the procedures in paragraph 2-163 to replace push switches.

2-167. Replace/Repair Power Distribution Panel P211.

This task covers: a. Removal, b. Repair, c. Replacement.

**INITIAL SETUP**

Tools

Tool kit, electrician's,  
5180-00-391-1087

Equipment Condition

Main switchboard MCHRY SPACES VENT  
PANEL P211 125AT/UVT circuit breaker  
OFF and tagged "Out of Service - Do  
Not Operate." TM 55-1905-223-10.

Materials/Parts

Circuit breaker P/N Q375HM  
Circuit breaker P/N Q315HM  
Push switch P/N 10250H671  
Warning tag, Item 1, Appendix C

WARNING

Death, serious injury, or equipment damage can result from contact with live electrical circuits. Before beginning work on this, or any other electrical equipment, turn power and control voltage circuit breakers OFF and tag 'Out of Service - Do Not Operate.'

Refer to the procedures in paragraph 2-159 to replace and repair the power distribution panel, door assembly, plug in breaker unit, and main interior lug.

Refer to the procedures in paragraph 2-163 to replace the push switch.

2-168. Replace/Repair Water Heater Disconnect Switch. (FIGURE 2-150)

---

This task covers: a. Removal, b. Repair. c. Replacement.

---

INITIAL SETUP

Tools

Tool kit, electrician's,  
5180-00-391-1087

Materials/Parts

Disconnect switch P/N DH-323 FRK  
Warning tag, Item 1, Appendix C

Equipment Condition

Main switchboard HOT WATER HEATER P216  
35AT circuit breaker OFF and tagged  
"Out of Service - Do Not Operate."  
TM 55-1905-223-10.

---

WARNING

Death, serious injury, or equipment damage can result from contact with live electrical circuits. Before beginning work on this, or any other electrical equipment, turn power and control voltage circuit breakers OFF and tag "Out of Service - Do Not Operate."

REMOVAL

- a. Open door (1).
- b. Tag and disconnect electrical wiring (4).
- c. Remove three mounting screws (2).
- d. Remove disconnect switch (3).

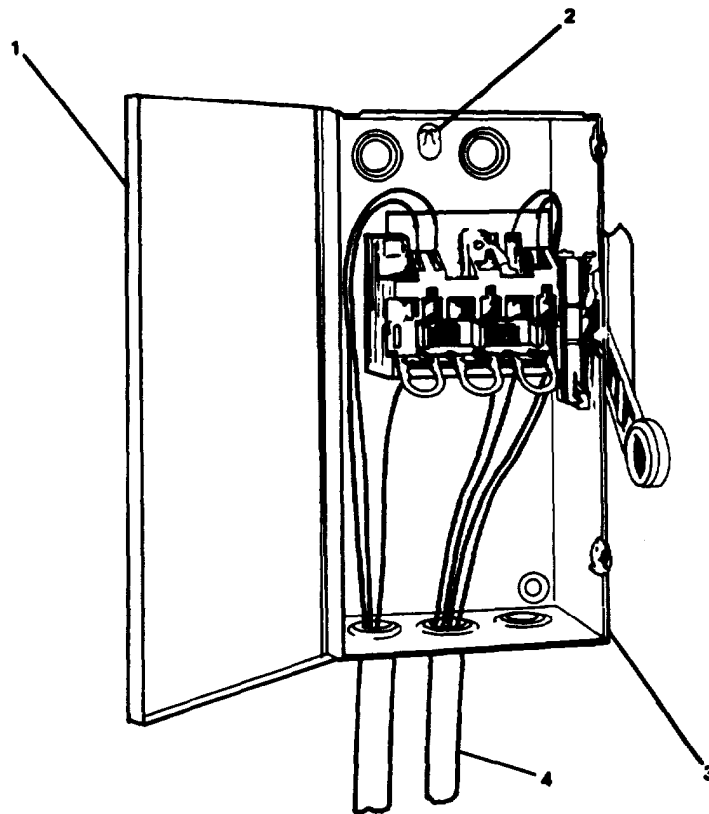
REPAIR

Repair is by replacement of disconnect switch.



**REPLACEMENT**

- a. Position disconnect switch (3).
- b. Install three mounting screws (2).
- c. Install electrical wiring (4). Remove tags.
- d. Close door (1).
- e. Turn main switchboard circuit breaker ON. Remove tag.

FIGURE 2-150. Disconnect Switch.

---

2-169. Replace Fresh Water Pump Number 1 Power Distribution.

---

Replacement of fresh water pump number 1 power distribution is by replacement of electrical cables. Evacuate to intermediate direct support maintenance.

---

2-170. Replace Fresh Water Pump Number 2 Power Distribution.

---

Replacement of fresh water pump number 2 power distribution is by replacement of electrical cables. Evacuate to intermediate direct support maintenance.

---

2-171. Replace Stem Winch Anchor Power Distribution.

---

Replacement of stern winch anchor power distribution is by replacement of electrical cables. Evacuate to intermediate direct support maintenance.

---

2-172. Replace Boat Davit Power Distribution.

---

Replacement of boat davit power distribution is by replacement of electrical cables. Evacuate to intermediate direct support maintenance.

2-173. Replace Bilge/Ballast Pump Power Distribution.

---

Replacement of bilge/ballast pump power distribution is by replacement of electrical cables. Evacuate to intermediate direct support maintenance.

---

2-174. Replace Welder Power Distribution.

---

Replacement of welder power distribution is by replacement of electrical cables.  
Evacuate to intermediate direct support maintenance.

2-175. Replace Welder Disconnect Switch.

---

This task covers: a. Removal, b. Replacement.

---

INITIAL SETUP

Tools

Tool kit, electrician's,  
5180-00-391-1087

Materials/Parts

Disconnect switch P/N DH-323 FRK  
Warning tag, Item 1, Appendix C

---

Equipment Condition

Main switchboard WELDER P223 125AT  
circuit breaker OFF and tagged "Out  
of Service - Do Not Operate." TM 55-  
1905-223-10.

WARNING

**Death, serious injury, or equipment damage can result from contact with live electrical circuits. Before beginning work on this, or any other electrical equipment, turn power and control voltage circuit breakers OFF and tag "Out of Service - Do Not Operate."**

**NOTE**

Refer to paragraph 2-168 for removal, and replacement procedures.



---

2-176. Replace Fire Pump Number 1 Power Distribution.

---

This task covers: a. Removal, b. Replacement.

---

INITIAL SETUP

Tools

Tool kit, electrician's,  
5180-00-391-1087

Materials/Parts

Push switch P/N 10250H671  
Warning tag, Item 1, Appendix C

---

Equipment Condition

Main switchboard FIRE PUMP 1 P225  
100AT circuit breaker OFF and tagged  
"Out of Service - Do Not Operate."  
TM 55-1905-223-10.

WARNING

**Death, serious injury, or equipment damage can result from contact with live electrical circuits. Before beginning work on this, or any other electrical equipment, turn power and control voltage circuit breakers OFF and tag "Out of Service - Do Not Operate."**

NOTE

Replacement of fire pump number 1 power distribution is by replacement of the push switch. Refer to TM 55-1905-223-10 for location of push switches.

Refer to the procedures in paragraph 2-163 to replace the push switch.

2-177. Replace 120V Power Distribution.

---

This task covers: a. Removal, b. Replacement.

---

INITIAL SETUP

Tools

Tool kit, electrician's,  
5180-00-391-1087

Materials/Parts

Warning tag, Item 1, Appendix C

---

Equipment Condition

Disconnect input power to the panel(s)  
being replaced and tag "Out of  
Service - Do Not Operate."  
TM 55-1905-223-10.

Replacement of 120V power distribution is by replacement of the components in the power distribution system. Refer to paragraphs 2-178 through 2-183.

---

2-178. Replace/Repair Power Distribution Panel P101.

---

This task covers: a. Removal, b. Repair, c. Replacement.

---

### INITIAL SETUP

#### Tools

Tool kit, electrician's,  
5180-00-391-1087

#### Equipment Condition

Main switchboard QTRS HEATER PANEL  
P101 125AT UVT circuit breaker OFF  
and tagged "Out of Service - Do Not  
Operate." TM 55-1905-223-10.

#### Materials/Parts

Circuit breaker P/N Q215HM  
Circuit breaker P/N Q220HM  
Circuit breaker P/N Q225HM  
Circuit breaker P/N Q230HM  
Circuit breaker P/N Q235HM  
Thermostat P/N M7D  
Warning tags, Item 1, Appendix C

---

### WARNING

**Death, serious injury, or equipment damage can result from contact with live electrical circuits. Before beginning work on this, or any other electrical equipment, turn power and control voltage circuit breakers OFF and tag "Out of Service - Do Not Operate."**

### REMOVAL

- a. Remove thermostats.

#### NOTE

Refer to TM 55-1905-223-10 for location of thermostats.

- (1) Remove thermostat cover (3, FIGURE 2-151).
- (2) Remove mounting screws (2).
- (3) Tag and disconnect wiring from thermostat (1).
- (4) Remove thermostat.

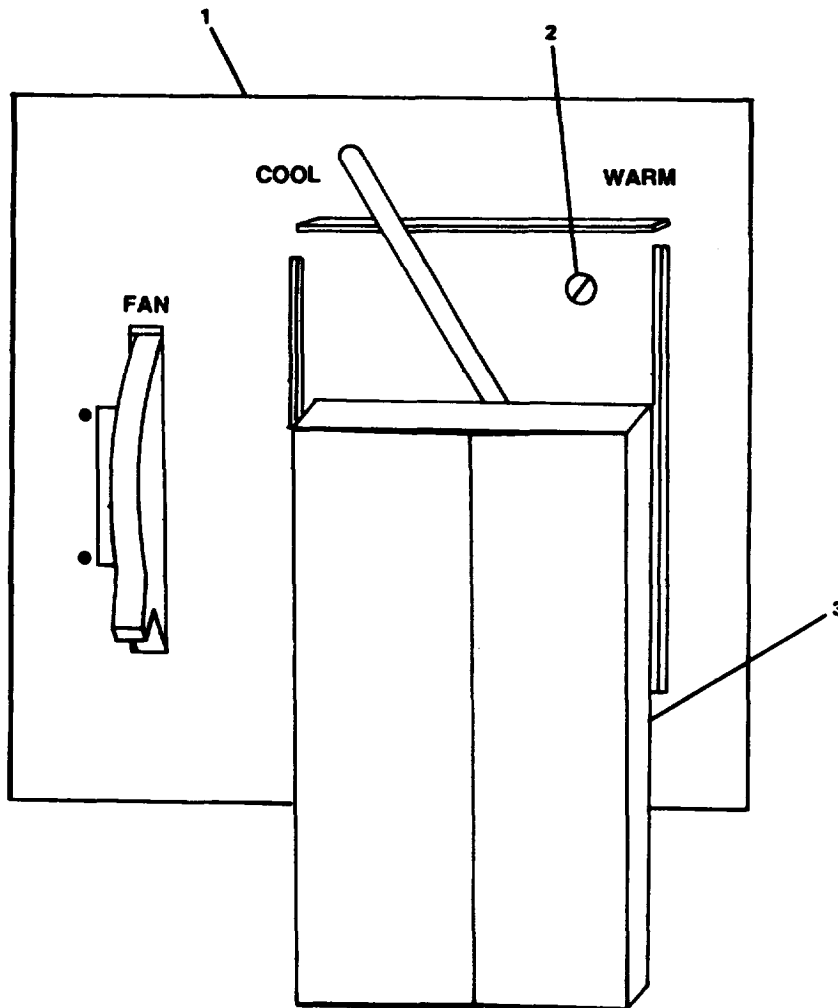


FIGURE 2-151. Thermostat Replacement.

- b. Remove door assembly.
  - (1) Open door (8, FIGURE 2-152).
  - (2) Remove four mounting bolts (7).
  - (3) Remove panel cover (1) and door assembly (8).
  - (4) Remove machine screws (5), springs (4), latches (6), push on nuts (2), and spring washers (3).
  - (5) Remove panel insert (9).
- c. Remove circuit breakers.
  - (1) Tag associated circuit breaker wiring (16, sheet 2).
  - (2) Loosen wire mounting screw on circuit breaker (15) and remove wire (16) from circuit breaker (15).
  - (3) Grasp circuit breaker (15) on end nearest center of panel and pull out to remove circuit breaker from panel.
- d. Remove breaker plug in unit.
  - (1) Remove machine screws (17).
  - (2) Remove breaker plug in unit (18).
- e. Remove main interior lug.
  - (1) Remove attaching screws (19).
  - (2) Remove main interior lug (20).
- f. Remove power distribution panel.
  - (1) Tag and disconnect electrical power cables (14, sheet 1).
  - (2) Remove four wing nuts (10), star nuts (11), and machine screws (12).
  - (3) Remove power distribution panel (13).

### **REPAIR**

Repair of power distribution panel is by replacement of circuit breakers and thermostats. Repair of door assembly, breaker plug in unit, and main interior lug is by replacement of the components.

### **REPLACEMENT**

- a. Replace thermostats.
  - (1) Connect wiring to thermostat (1, FIGURE 2-151).

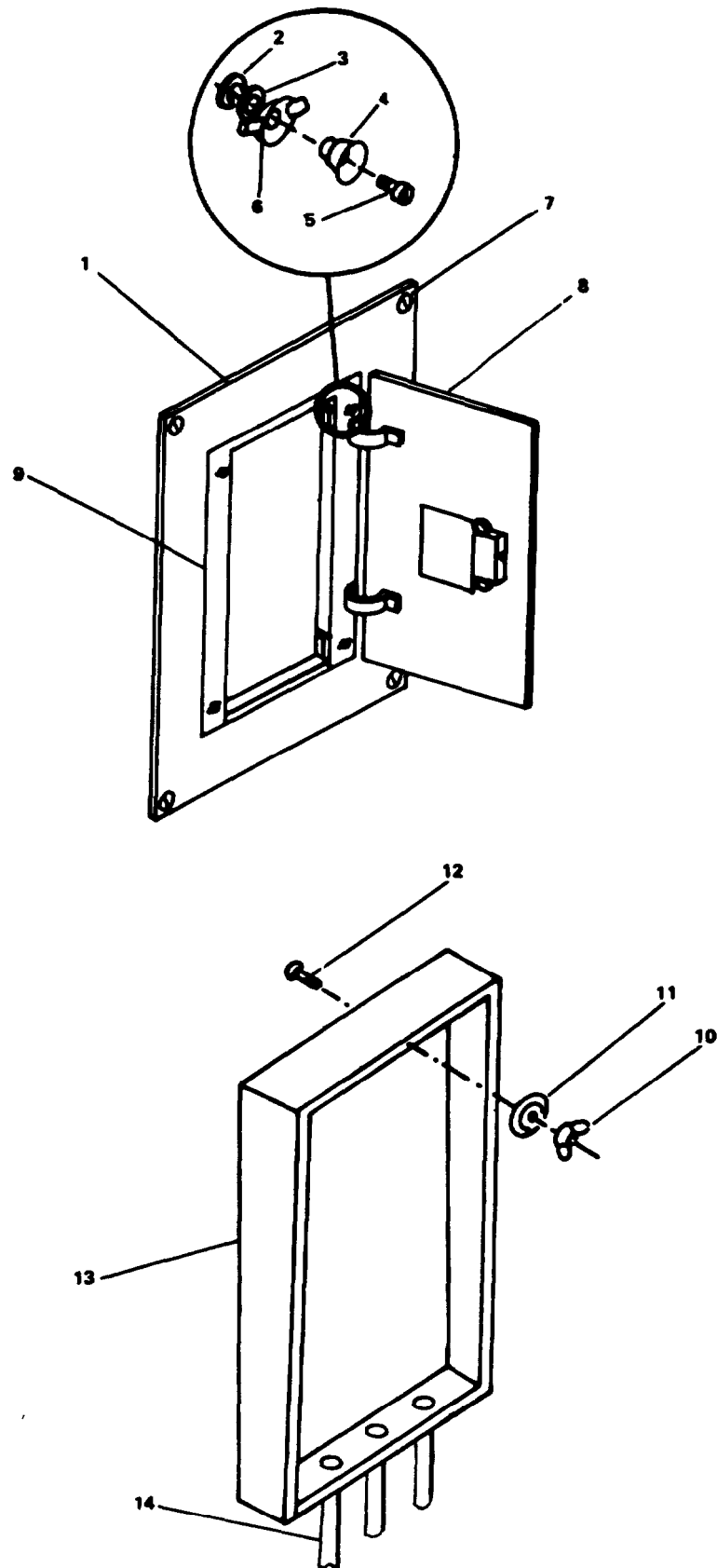
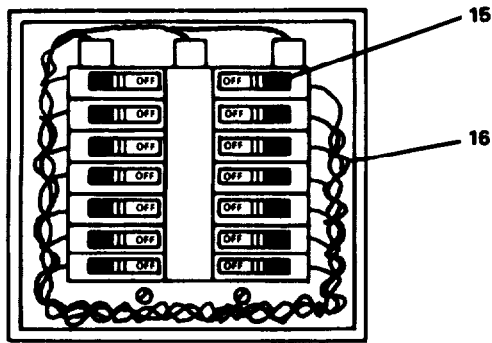


FIGURE 2-152. Power Distribution Panel Removal (Sheet 1 of 2).



8079

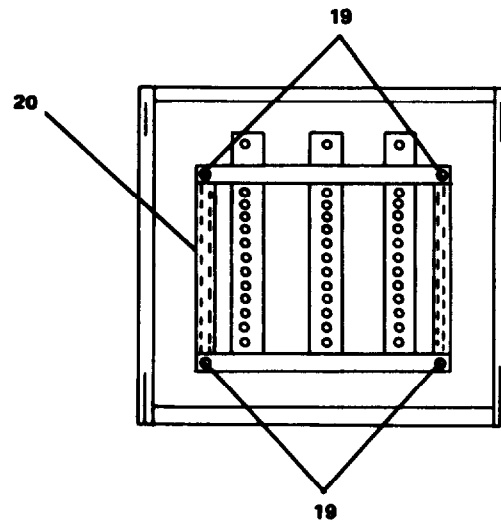
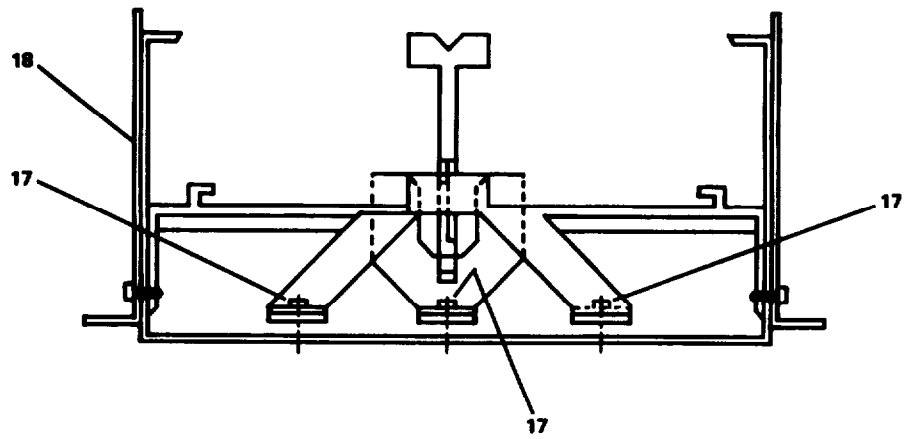


FIGURE 2-152. Power Distribution Panel Removal (Sheet 2 of 2).

**TM 55-1905-223-24-18-1**

- (2) Position thermostat (1) and secure with mounting screws (2).
  - (3) Replace thermostat cover (3).
  - (4) Turn power panel circuit breaker ON. Remove tag.
- b. Replace power distribution panel.
- (1) Position power distribution panel (13, FIGURE 2-152).
  - (2) Secure with four machine screws (12), star nuts (11) and wing nuts (10).
  - (3) Remove tags and connect electrical cables (14).
- c. Replace main interior lug.
- (1) Install main interior lug (20, sheet 2).
  - (2) Secure with attaching screws (19).
- d. Replace breaker plug in unit.
- (1) Install breaker plug in unit (18).
  - (2) Secure with machine screws (17).
- e. Replace circuit breakers.
- (1) Push circuit breaker (15) on end nearest center of panel to lock circuit breaker in panel.
  - (2) Attach wire (16) to circuit breaker. Tighten wire mounting screw on circuit breaker. Remove tag.
- f. Replace door assembly.
- (1) Install panel insert (9, sheet 1)
  - (2) Secure with spring washers (3), push on nuts (2), latches (6), springs (4) and machine screws (5).
  - (3) Install panel cover (1) and door assembly (8).
  - (4) Secure with mounting bolts (7).
  - (5) Close door (8).
- g. Turn power on, remove tags.



---

2-179. Replace/Repair Power Distribution Panel L102.

---

This task covers: a. Removal, b. Repair, c. Replacement.

---

### INITIAL SETUP

#### Tools

Tool kit, electrician's,  
5180-00-391-1087

#### Equipment Condition

Main switchboard ENG ROOM LIGHTING  
PANEL L102 100AT circuit breaker OFF  
and tagged "Out of Service - Do Not  
Operate." TM 55-1905-223-10.

#### Materials/Parts

Circuit breaker P/N Q215HM  
Circuit breaker P/N Q22HM  
Receptacle P/N 2702A  
Receptacle P/N 2403A-125  
Receptacle P/N 2634A  
Incandescent lamp P/N INX3528  
Incandescent lamp P/N A19  
Fluorescent lamp P/N F20T22  
Fluorescent lamp P/N F8T5  
Warning tag, Item 1, Appendix C

---

### WARNING

**Death, serious injury, or equipment damage can result from contact with live electrical circuits. Before beginning work on this, or any other electrical equipment, turn power and control voltage circuit breakers OFF and tag "Out of Service - Do Not Operate."**

### REMOVAL

- a. Refer to the procedures in paragraph 2-178 to remove circuit breakers, door assembly, breaker plug in unit, main interior lug, and power panel.
- b. Remove Receptacles.
  - (1) Remove receptacle P/N 2403A-125 (FIGURE 2-153).
    - (a) Open cover (1).
    - (b) Remove screw (2) and cover (1).
    - (c) Remove screws (4). Pull out receptacle (3).
    - (d) Disconnect wiring from receptacle (3). Remove receptacle (3).

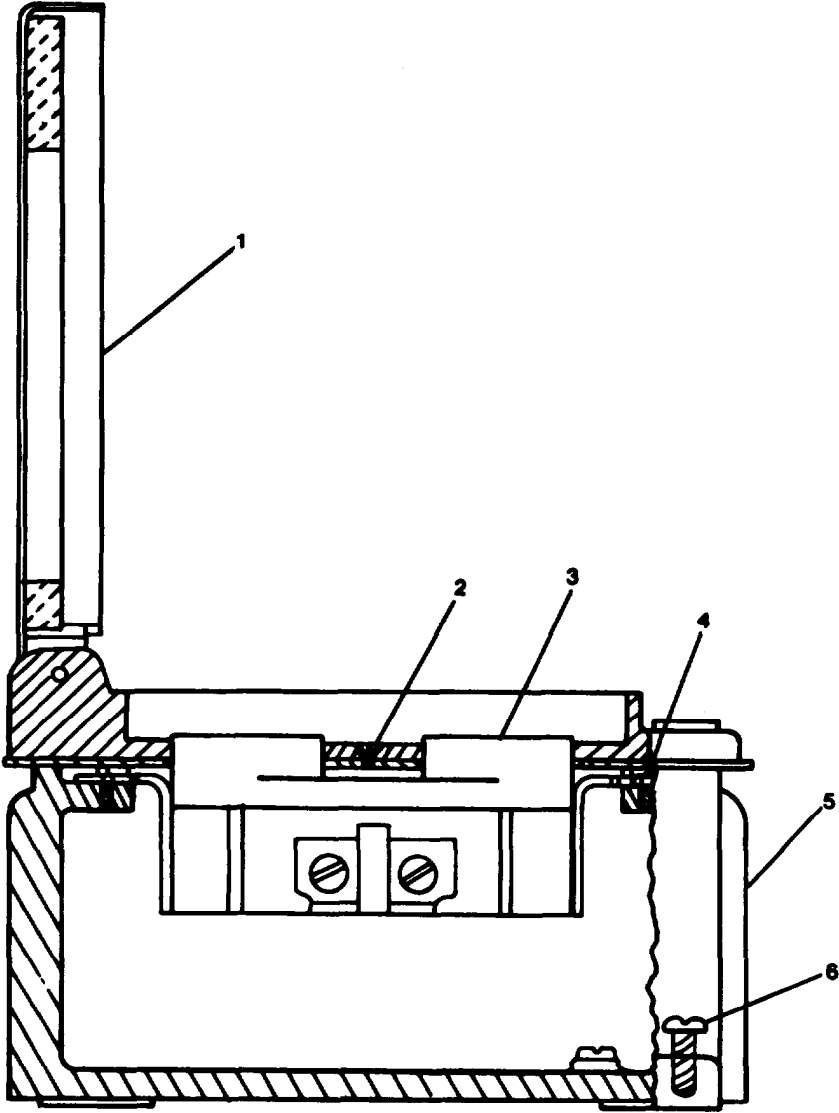


FIGURE 2-153. Receptacle P/N 2403A-125 Replacement.

- (e) Remove mounting screws (6). Remove box (5).
- (2) Remove receptacle P/N 2634A (FIGURE 2-154).
  - (a) Remove screws (1).
  - (b) Remove cover.
  - (c) Disconnect wiring from receptacles.
  - (d) Remove mounting screws (4). Remove body (3).
- (3) Remove receptacles P/N 2702A and 2702AF (FIGURE 2-155).
  - (a) Remove screws (2) and cover (1).
  - (b) Remove screws (3). Pull out receptacle (4).
  - (c) Remove wiring from receptacle (4). Remove receptacle (4).
- c. Remove Incandescent Lamp (FIGURE 2-156)

**WARNING**

**Hot lamps can cause burns. Wear gloves when removing hot lamps.**

- (1) Unscrew and remove cage (4), if attached.
- (2) Unscrew and remove globe (3).
- (3) Remove bulb (2).
- d. Remove Fluorescent Lamps.
  - (1) Remove fluorescent lamps from ceiling fixtures (FIGURE 2-157).
    - (a) Remove knurled screws (5) and lens frame (1).
    - (b) Unclip and swing down or remove lens (3).
    - (c) Use two hands to grasp both ends of fluorescent lamp (2).
    - (d) Rotate lamp (2) until loose.
    - (e) Remove lamp (2).
  - (2) Remove exit light lamp (FIGURE 2-158).
    - (a) Remove knurled screws (1).
    - (b) Remove cover (3).
    - (c) Use two hands to grasp both ends of fluorescent lamp (2).

(d) Rotate lamp (2) until loose.

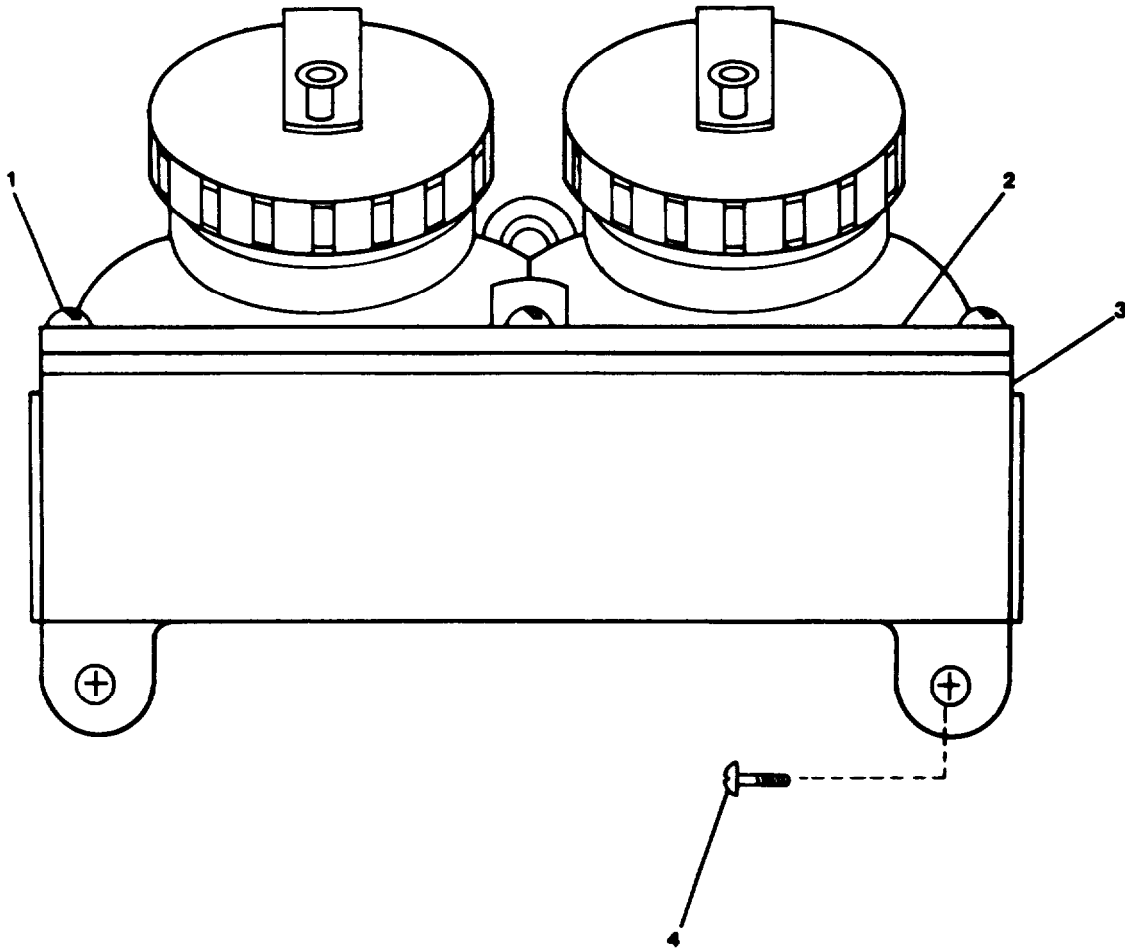


FIGURE 2-154. Receptacle P/N 2634A Replacement.

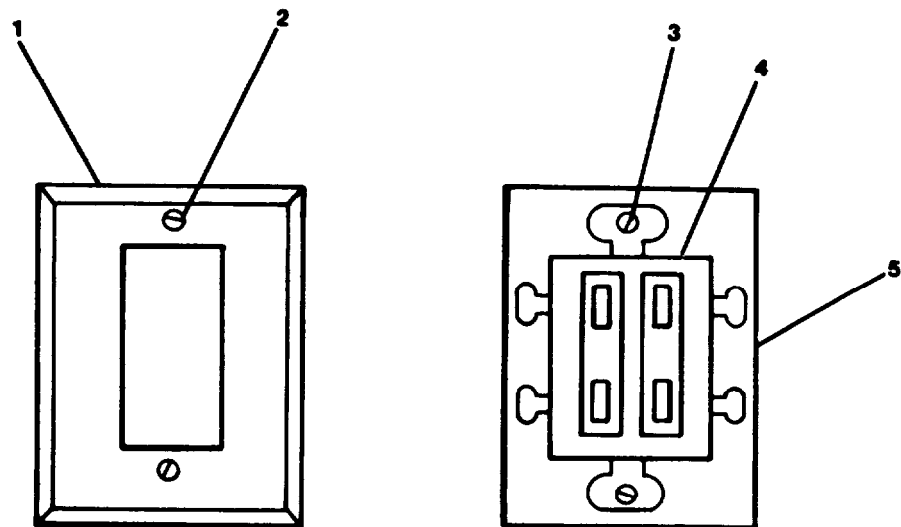


FIGURE 2-155. Receptacle P/N 2702A and 2702AF Replacement.

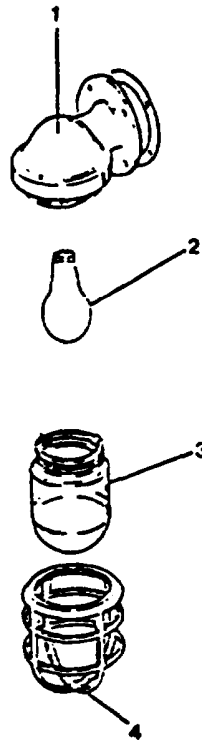


FIGURE 2-156. Incandescent Lamp Replacement.

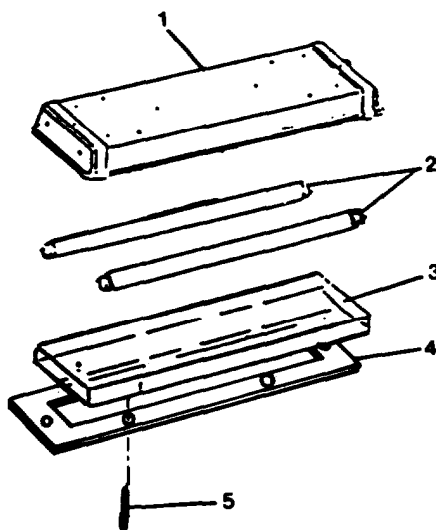


FIGURE 2-157. Ceiling Fixture Lamp Replacement.

(e) Remove lamp (2).

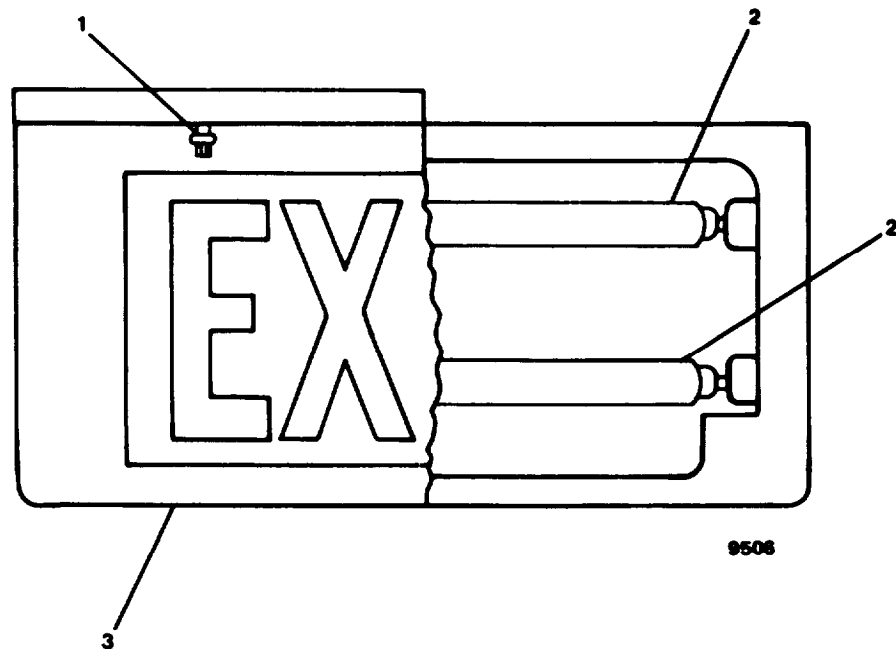


FIGURE 2-158. Exit Light Lamp Replacement.

### REPAIR

Repair of power distribution panel L102 is by replacement of circuit breakers, receptacles and incandescent and fluorescent lamps. Repair of the door assembly, breaker plug in unit and main interior lug is by replacement of the components.

### REPLACEMENT

- a. Refer to the procedures in paragraph 2-178 to replace circuit breaker, door assembly, breaker plug in unit, main interior lug, and power panel.
- b. Replace receptacles.
  - (1) Replace receptacle P/N 2403A-125. (FIGURE 2-153)
    - (a) Position box (5). Secure with mounting screws (6).
    - (b) Connect wiring to receptacle (3). Position receptacle (3) in box (5).
    - (c) Secure receptacle (3) with screws (4).
    - (d) Position cover (1) on box (5). Secure with screw (2).
    - (e) Close cover (1).

- (2) Replace receptacle P/N 2634A. (FIGURE 2-154)
  - (a) Position body (3). Secure with mounting screws (4).
  - (b) Connect wiring to receptacles.
  - (c) Position cover (2). Secure with screws (1).
  - (d) Turn associated circuit breaker ON. Remove tag.
- (3) Replace receptacles P/N 2702A and 2702AF. (FIGURE 2-155)
  - (a) Connect wiring to receptacle (4).
  - (b) Position receptacle (4) in box (5). Secure with screws (3).
  - (c) Replace cover (1). Secure with screws (2).
- c. Replace incandescent lamps.
  - (1) Screw incandescent lamp (2) into lighting fixture (1) (FIGURE 2-156).
  - (2) Replace globe (3).
  - (3) Replace cage (4) if removed.
  - (4) Turn power panel circuit breaker ON. Remove tag.
- d. Replace fluorescent lamps. (FIGURE 2-157)
  - (1) Replace fluorescent lamps in ceiling fixtures.
    - (a) Use two hands to grasp both ends of fluorescent lamp (2).
    - (b) Install lamp (2) and rotate until tight.
    - (c) Replace lens (3).
    - (d) Replace lens frame (4). Secure with knurled screws (5).
  - (2) Replace exit light lamp. (FIGURE 2-158)
    - (a) Use two hands to grasp both ends of fluorescent lamp (2).
    - (b) Install lamp (2) and rotate until tight.
    - (c) Replace cover (3). Secure with knurled screws (1).
- e. Restore power. Remove tags.



---

2-180. Replace/Repair Power Distribution Panel L104.

---

This task covers: a. Removal, b. Repair, c. Replacement.

---

INITIAL SETUP

Tools

Tool kit, electrician's,  
5180-00-391-1087

Equipment Condition

Main switchboard MN DECK LIGHTING  
PANEL L104 100AT circuit breaker  
OFF and tagged "Out of Service -  
Do Not Operate." TM 55-1905-223-10.

Materials/Parts

Circuit breaker P/N Q215HM  
Incandescent lamp P/N INX 3528  
Incandescent lamp P/N A19  
Fluorescent lamp P/N F20T12  
Fluorescent lamp P/N F8T5  
Fluorescent lamp P/N F15T8  
Warning tag, Item 1, Appendix C

---

**WARNING**

**Death, serious injury, or equipment damage can result from contact with live electrical circuits. Before beginning work on this, or any other electrical equipment, turn power and control voltage circuit breakers OFF and tag "Out of Service - Do Not Operate."**

Refer to the procedures in paragraph 2-179 to replace and repair the fluorescent and incandescent lamps, power distribution panel, door assembly, plug in breaker unit and main interior lug.

2-181. Replace/Repair Power Distribution Panel L105.

---

This task covers: a. Removal, b. Repair, c. Replacement.

---

INITIAL SETUP

Tools

Tool kit, electrician's,  
5180-00-391-1087

Materials/Parts

Circuit breaker P/N Q215H  
Fluorescent lamp P/N F20T12  
Receptacle P/N 2634A  
Receptacle P/N 2702AF  
Warning tag, Item 1, Appendix C

Equipment Condition

Main switchboard WHEEL HOUSE LIGHTING  
PANEL L105 45AT circuit breaker OFF  
and tagged "Out of Service - Do Not  
Operate." TM 55-1905-223-10.

---

**WARNING**

**Death, serious injury, or equipment damage  
can result from contact with live electrical  
circuits. Before beginning work on this, or  
any other electrical equipment, turn power  
and control voltage circuit breakers OFF and  
tag "Out of Service - Do Not Operate."**

Refer to the procedures in paragraph 2-178 to replace and repair the power  
distribution panel, door assembly, plug in breaker unit and main interior lug.

---

**2-182. Replace/Repair Floodlights.**

---

This task covers: a. Removal, b. Repair, c. Replacement.

---

**INITIAL SETUP****Tools**

Tool kit, electrician's,  
5180-00-391-1087

**Materials/Parts**

Lamp ballast P/N INX5023  
Floodlight P/N HIDMA4RBWB  
Floodlight P/N HIDMAIDRBNB  
Gasket P/N GKT3008  
Gasket P/N GKT6052-72  
Gasket P/N IN2685C-9  
Gasket P/N GKT6024  
Lens P/N INX 2124  
Lens P/N INX 2125  
Mercury vapor lamp P/N INX 3524  
Mercury vapor lamp P/N INX 3520  
Warning tag, Item 1, Appendix C

**Equipment Condition**

Power distribution panel L105  
circuit breaker OFF and tagged  
"Out of Service - Do Not Operate."  
TM 55-1905-223-10.

---

**WARNING**

**Death, serious injury, or equipment damage can result from contact with live electrical circuits. Before beginning work on this, or any other electrical equipment, turn power and control voltage circuit breakers OFF and tag "Out of Service - Do Not Operate."**

**REMOVAL****a. Remove Floodlight.**

- (1) Disconnect electrical connection (stuffing tubes) from floodlight (1, FIGURE 2-159).
- (2) Remove three mounting bolts and nuts (2).
- (3) Remove floodlight (1).

**TM 55-1905-223-24-18-1**

b. Remove Floodlight Lamp.

- (1) Remove eight nuts (4, FIGURE 2-160).
- (2) Remove access plate (3) and gasket (2). Discard gasket (2).

**WARNING**

Do not touch lamp with bare hands. To prevent personal injury or equipment damage, wear gloves when removing and installing mercury vapor lamps.

- (3) Remove lamp (1).

c. Remove Lens.

- (1) Remove 16 nuts (5).
- (2) Remove lens frame (5), lens (7), and gasket (6).

d. Remove Lamp Ballast.

- (1) Remove 8 hexagon screws (2, FIGURE 2-161)
- (2) Remove cover (2).
- (3) Tag and disconnect electrical wiring.
- (4) Remove 4 screws (3). Remove lamp ballast (4).

**REPAIR**

Repair of the floodlight is by replacement of the lamp, lens, gaskets and lamp ballast.

**REPLACEMENT**

a. Replace Floodlight Lens.

- (1) Position lens (7, FIGURE 2-160), gasket (6), and lens frame (8)
- (2) Secure with 16 nuts (5).

b. Replace Floodlight Lamp.

- (1) Install lamp (1).
- (2) Position gasket (2) and access plate (3).
- (3) Secure with eight nuts (4).

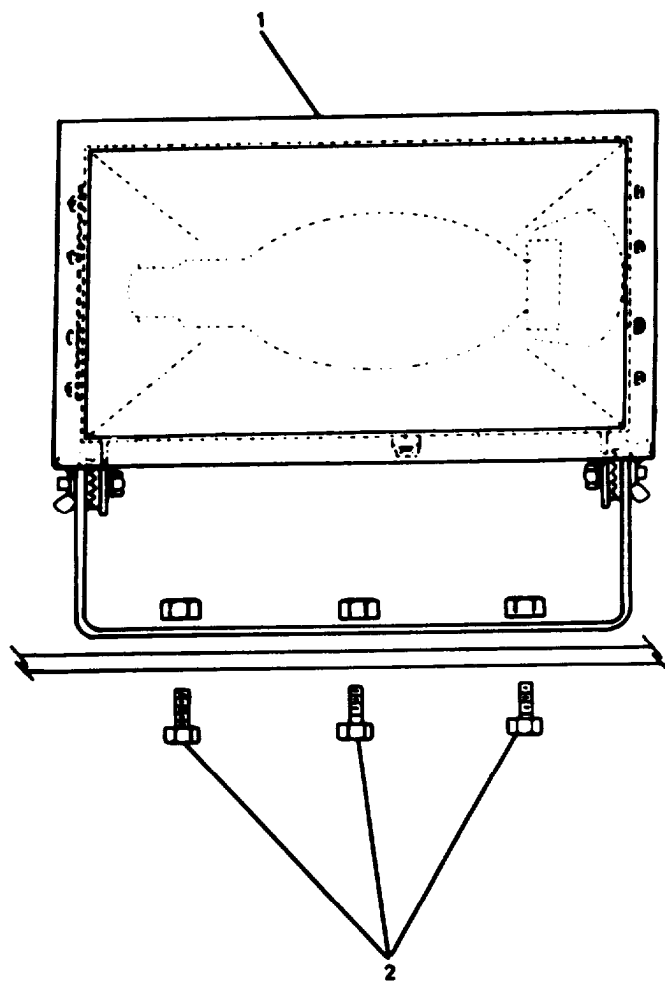


FIGURE 2-159. Floodlight Replacement.

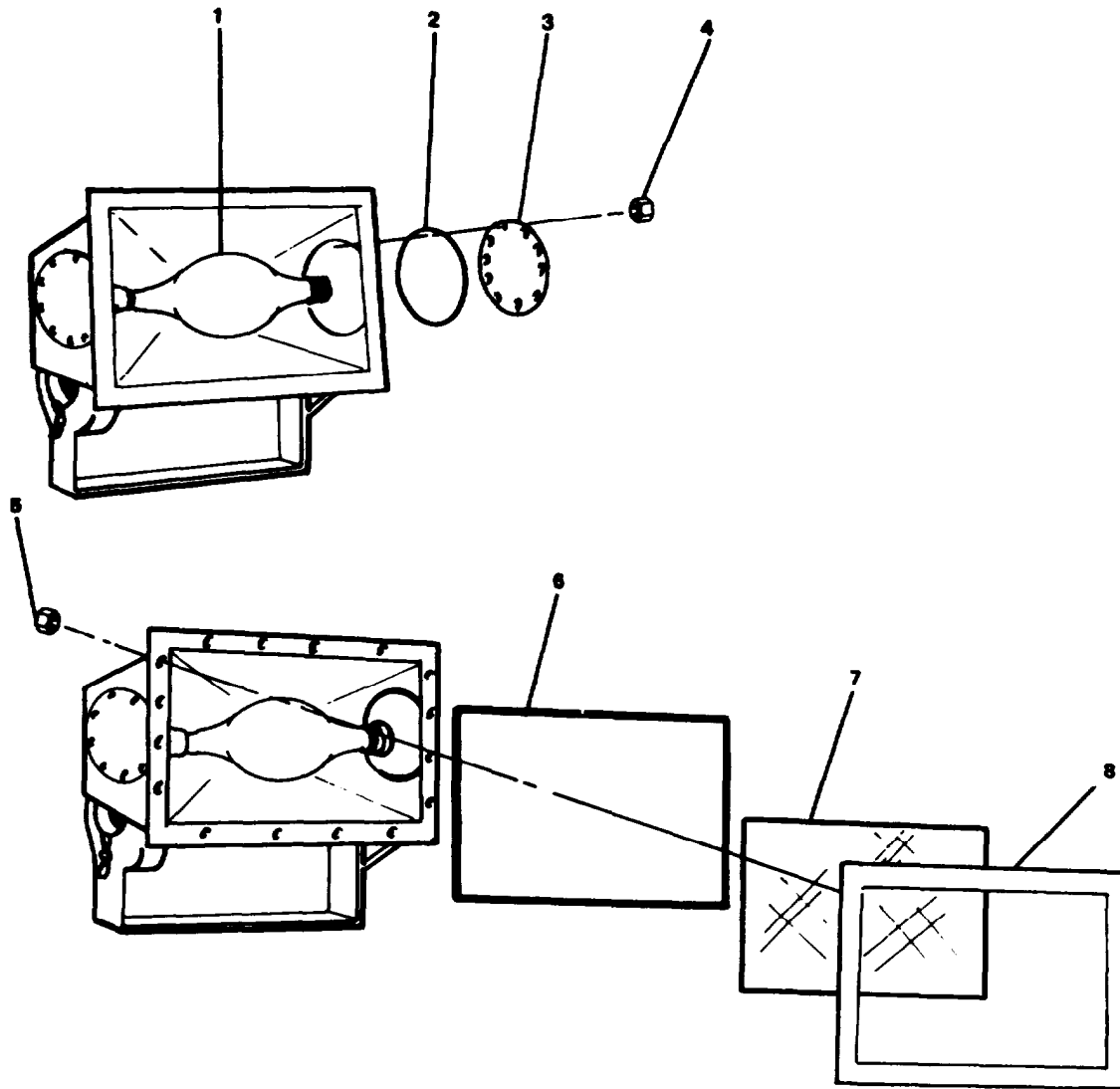


FIGURE 2-160. Floodlight Repair.

c. Replace Floodlight.

- (1) Position floodlight (1, FIGURE 2-159). Secure with three mounting bolts and nuts (2).
- (2) Connect electrical connection.

d. Replace Lamp Ballast.

- (1) Install lamp ballast (4, FIGURE 2-161). Secure with 4 screws (3).
  - (2) Connect electrical wiring, remove tag.
  - (3) Install cover (2). Secure with 8 hexagon screws (2).
- e. Turn power panel circuit breaker ON. Remove tag.

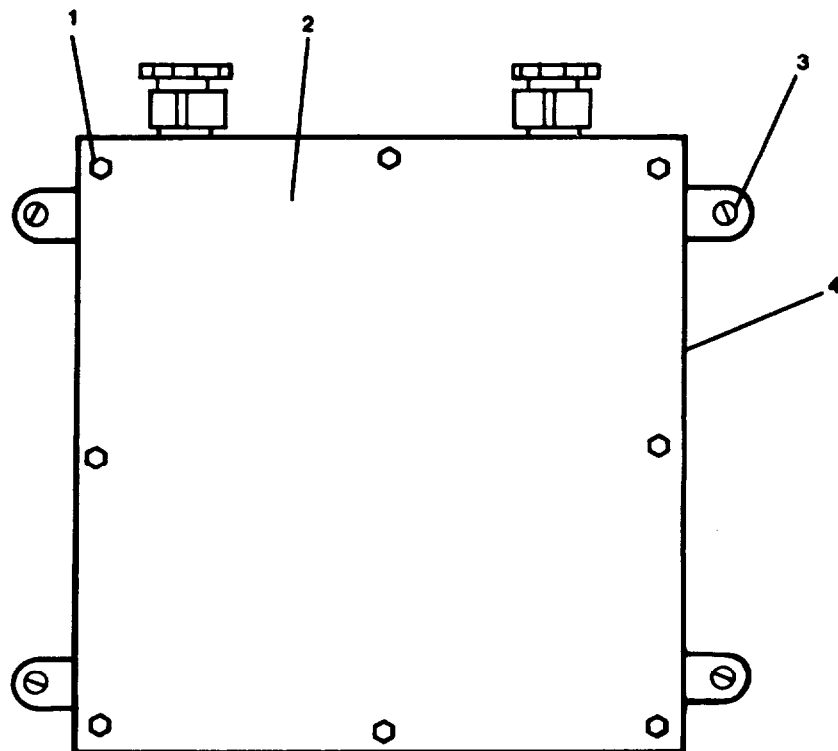


FIGURE 2-161. Lamp Ballast Replacement.

2-183. Replace/Repair Power Distribution Panel P106.

---

This task covers: a. Removal, b. Repair, c. Replacement

---

INITIAL SETUP

Tools

Tool kit, electrician's,  
5180-00-391-1087

Equipment Condition

Main switchboard GALLEY 120V PANEL  
P106 BOAT circuit breaker OFF and  
tagged "Out of Service - Do Not  
Operate." TM 55-1905-223-10.

Materials/Parts

Circuit breaker P/N Q215H  
Circuit breaker P/N Q220H  
Circuit breaker P/N Q225H  
Warning tag, Item 1, Appendix C

---

WARNING

**Death, serious injury, or equipment damage can result from contact with live electrical circuits. 'Before beginning work on this, or any other electrical equipment, turn power and control voltage circuit breakers OFF and tag "Out of Service - Do Not Operate."**

Refer to the procedures in paragraph 2-178 to replace and repair the power distribution panel, door assembly, plug in breaker unit and main interior lug.



---

2-184. Replace/Replace 240V Emergency Power Distribution.

---

This task covers: a. Removal, b. Replacement.

---

INITIAL SETUP

Tools

Tool kit, electrician's,  
5180-00-391-1087

Equipment Condition

Disconnect input power to the panel  
to be replaced and tag "Out of  
Service - Do Not Operate."

Materials/Parts

Warning tag, Item 1, Appendix C

---

Replacement and repair of 240V emergency power distribution is by replacement of components in the power distribution system. Evacuate to intermediate direct support maintenance.

2-185. Replace/Replace 120V Emergency Power Distribution.

---

This task covers: a. Removal, b. Repair, c. Replacement.

---

INITIAL SETUP

Tools

Tool kit, electrician's,  
5180-00-391-1087

Materials/Parts

Warning tag, Item 1, Appendix C

---

Equipment Condition

Disconnect input power to the distribution to be replaced/repared and tag "Out of Service - Do Not Operate." TM 55-1905-223-10.

Replace and repair of 120V emergency power distribution is by replacement of the components in the power distribution system. Refer to paragraphs 2-186 through 2-188.

---

2-186. Replace/Repair Power Distribution Panel EL102.

---

This task covers: a. Removal, b. Repair, c. Replacement.

---

### INITIAL SETUP

#### Tools

■ Tool kit, electrician's,  
5180-00-391-1087

#### Materials/Parts

Circuit breaker P/N Q215H  
Circuit breaker P/N Q225H  
Fluorescent lamp P/N F20T12  
Fluorescent lamp P/N F8T5  
Warning tag, Item 1, Appendix C

---

#### Equipment Condition

Emergency switchboard WH4HSE EMG LTG  
PNL EL102 BOAT circuit breaker OFF  
and tagged "Out of Service - Do Not  
Operate." TM 55-1905-223-10.

### WARNING

**Death, serious injury, or equipment damage can result from contact with live electrical circuits. Before beginning work on this, or any other electrical equipment, turn power and control voltage circuit breakers OFF and tag "Out of Service - Do Not Operate."**

Refer to the procedures in paragraph 2-178 to replace and repair the power distribution panel, door assembly, plug in breaker unit and main interior lug.

2-187. Replace/Repair Floodlights.

---

This task covers: a. Removal, b. Repair, c. Replacement.

---

INITIAL SETUP

Tools

Tool kit, electrician's,  
5180-00-391-1087

Materials/Parts

Lamp ballast P/N INX5023  
Floodlight P/N HIDMAGRWBW  
Gasket P/N GKT3008  
Gasket P/N GKT6024  
Lens P/N INX 2125  
Mercury vapor lamp P/N INX 3524  
Warning tag, Item 1, Appendix C

Equipment Condition

Associated power distribution panel'  
circuit breaker OFF and tagged  
"Out of Service - Do Not Operate."  
TM 55-1905-223-10.

---

WARNING

**Death, serious injury, or equipment damage can result from contact with live electrical circuits. Before beginning work on this, or any other electrical equipment, turn power and control voltage circuit breakers OFF and**

Refer to the procedures in paragraph 2-182 to replace/repair the floodlights.

2-188. Replace/Repair Power Distribution Panel EP103.

This task covers: a. Removal, b. Repair, c. Replacement.

INITIAL SETUP

Tools

Tool kit, electrician's,  
5180-00-391-1087

Equipment Condition

Emergency switchboard WHL/HSE/ELEX  
PNL EP103 35AT circuit breaker OFF  
and tagged "Out of Service - Do Not  
Operate." TM 55-1905-223-10.

Materials/Parts

Circuit breaker P/N Q215H  
Warning tag, Item 1, Appendix C

WARNING

**Death, serious injury, or equipment damage can result from contact with live electrical circuits. Before beginning work on this, or any other electrical equipment, turn power and control voltage circuit breakers OFF and tag "Out of Service - Do Not Operate."**

Refer to the procedures in paragraph 2-178 to replace and repair in the power distribution panel, door assembly, plug in breaker unit and main interior lug.

---

2-189. Replace/Repair Emergency Power Lighting.

---

This task covers: a. Replacement, b. Repair.

---

INITIAL SETUP

Tools

Tool kit, electrician's,  
5180-090-391-1087

Materials/Parts

Fluorescent Lamp P/N F20T12  
Warning tag, Item 1, Appendix C

Equipment Condition

Emergency switchboard EMG LIGHT  
BELOW MN DECK EL108 15AT circuit  
breaker OFF and tagged "Out of  
Service - Do Not Operate."  
TM 55-1905-223-10.

WARNING

**Death, serious injury, or equipment damage can result from contact with live electrical circuits. Before beginning work on this, or any other electrical equipment, turn power and control voltage circuit breakers OFF and tag "Out of Service - Do Not Operate."**

REPLACEMENT

Replacement of emergency power lighting is by replacement of components in the lighting system. Evacuate to intermediate direct support maintenance.

REPAIR

**NOTE**

Repair of emergency power lighting at this level is by replacement of fluorescent lamps. Refer to FIGURE 2-157

- a. Remove knurled screws (5).
- b. Remove lens frame (4) and lens (3) from fixture (1).
- c. Use two hands to grasp both ends of fluorescent lamp (2).
- d. Rotate lamp (2) until loose.
- e. Remove lamp (2).

- f. Use two hands to grasp both ends of fluorescent lamp (2).
- g. Install lamp (2) and rotate until tight.
- h. Replace lens (3).
- i. Replace lens frame (4). Secure with knurled screws (5).
- j. Turn power panel circuit breaker ON. Remove tag.

---

2-190. Replace/Repair 24VDC Emergency Power Distribution.

---

This task covers: a. Removal, b. Repair, c. Replacement.

---

INITIAL SETUP

Tools

Tool kit, electrician's,  
5180-00-391-1087

Materials/Parts

Warning tag, Item 1, Appendix C

---

Equipment Condition

Disconnect input power to panel(s)  
to be replaced and tag "Out of  
Service - Do Not Operate."  
TM 55-1905-223-10.

REMOVAL

Repair and replacement of 24VDC emergency power distribution is by repair and replacement of the components in the power distribution system. Refer to paragraphs 2-191 and 2-192.



---

2-191. Replace Power Distribution Panel (EP024-1). (FIGURE 2-162)

---

This task covers: a. Removal, b. Replacement.

---

**INITIAL SETUP**

**Tools**

Tool kit, electrician's,  
5180-00-391-1087

**Equipment Condition**

Emergency switchboard WHEELHOUSE  
DC PANEL EP0241 15AT circuit breaker  
OFF and tagged "Out of Service - Do  
Not Operate." TM 55-1905-223.10.

**Materials/Parts**

Warning tag, Item 1, Appendix C

---

**WARNING**

**Death, serious injury, or equipment damage can result from contact with live electrical circuits. Before beginning work on this, or any other electrical equipment, turn power and control voltage circuit breakers OFF and tag "Out of Service - Do Not Operate."**

**REMOVAL**

- a. Remove electrical cables (1 through 7).
- b. Remove attaching parts. Remove power panel (8).

**REPLACEMENT**

- a. Install power panel (8). and attaching parts.
- b. Connect electrical cables (1 through 7).
- c. Apply power, Remove tag.

2-192. Replace Power Distribution Panel (EP024 SECT B). (FIGURE 2-162)

---

This task covers: a. Removal, b. Replacement.

---

### INITIAL SETUP

#### Tools

Tool kit, electrician's,  
5180-00-391-1087

#### Materials/Parts

Warning tag, Item 1, Appendix C

---

#### Equipment Condition

Emergency switchboard WHEELHOUSE  
DC PANEL EP0241 15AT circuit breaker  
OFF and tagged "Out of Service - Do  
Not Operate." TM 55-1905-223.10.

### WARNING

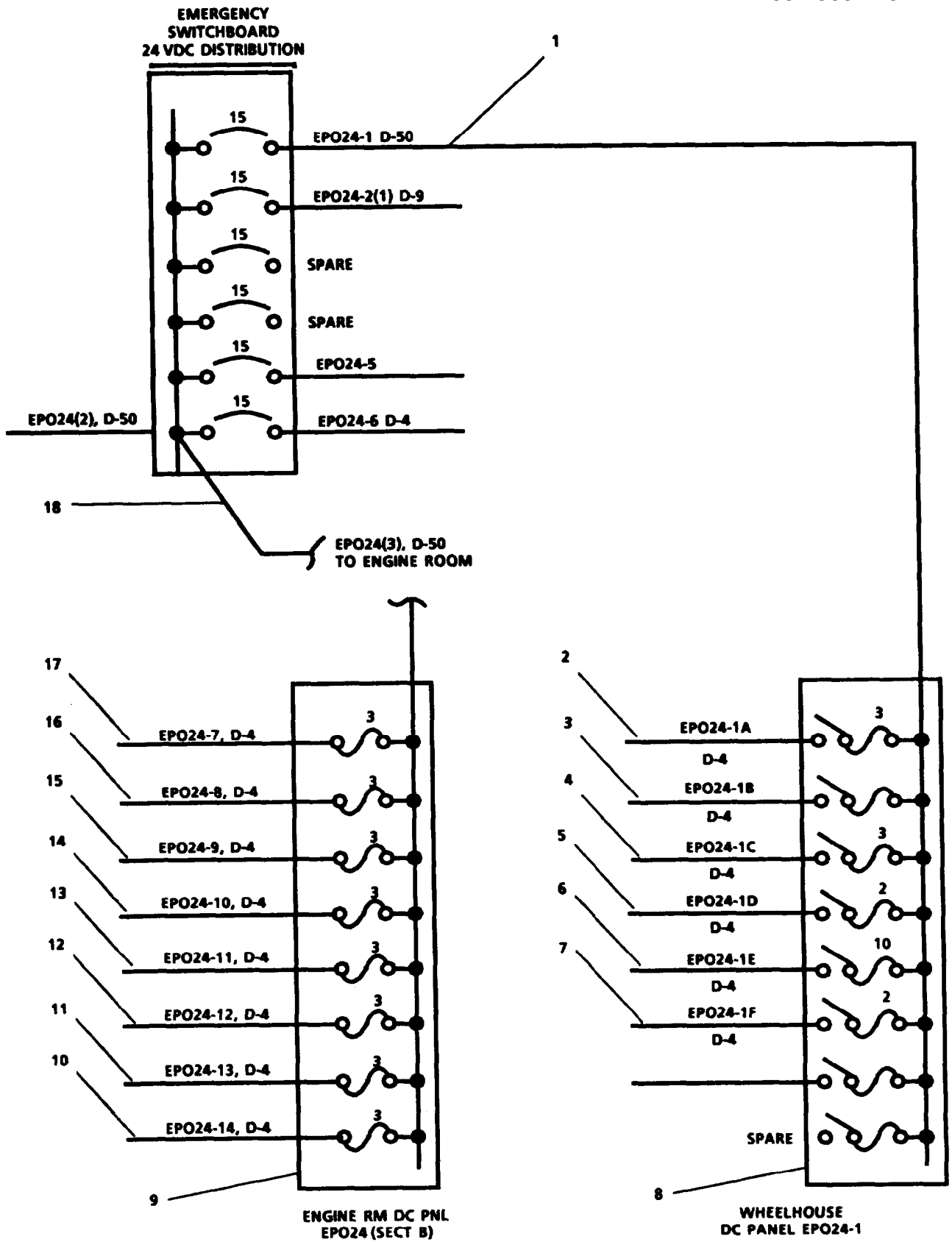
**Death, serious injury, or equipment damage can result from contact with live electrical circuits. Before beginning work on this, or any other electrical equipment, turn power and control voltage circuit breakers OFF and tag "Out of Service - Do Not Operate."**

### REMOVAL

- a. Remove electrical cables (10 through 17).
- b. Remove attaching parts. Remove power panel (9).

### REPLACEMENT

- a. Install power panel (9) and attaching parts.
- b. Connect electrical cables (10 through 17).
- c. Apply power. Remove tag.



2-162. Emergency Power 24 Volt Distribution.

2-193. Replace/Repair Battery Storage Group

---

This task covers: a. Removal, b. Repair, c. Replacement.

---

INITIAL SETUP

Tools

Tool kit, electrician's,  
5180-00-391-1087

Equipment Condition

Associated circuit breaker OFF  
and tagged "Out of Service -  
Do Not Operate" (TM 55-1905-223-10).

Materials/Parts

Warning tag, Item 1, Appendix C

---

REMOVAL

Repair and replacement of battery storage group is by replacement and repair of the components in the group. Refer to paragraph 2-194 through 2-203.

---

2-194. Repair Emergency Switchboard Assembly Battery. (FIGURE 2-163)

---

This task covers: a. Disassembly, b. Repair, c. Assembly.

---

### INITIAL SETUP

#### Tools

Tool kit, electrician's,  
5180-00-391-1087

#### Equipment Condition

EMER SWBD BATT CHGR EP110 40AT  
circuit breaker OFF and tagged  
"Out of Service - Do Not Operate."  
TM 55-1905-223-10.

#### Materials/Parts

Battery P/N COM-5D  
Warning tag, Item 1, Appendix C

---

### WARNING

**Death, serious injury, or equipment damage can result from contact with live electrical circuits. Before beginning work on this, or any other electrical equipment, turn power and control voltage circuit breakers OFF and tag "Out of Service - Do Not Operate."**

### DISASSEMBLY

- a. Remove battery box cover (1).

#### **NOTE**

To aid in reinstallation, tag the cable connected to the positive terminal before removing cables.

- b. Loosen cable hold down bolts and remove positive and negative cables (4) from battery (3).
- c. Remove battery (3) from battery box (2).

### REPAIR

Repair at this level is by replacement of battery.

ASSEMBLY

CAUTION

Ensure there is no foreign objects, such as loose nuts, on the bottom of the battery box. The battery could be damaged if placed on foreign objects.

- a. Place battery (3) in battery box (2). Ensure battery is level and that battery positive post is nearest to positive cable.
- b. Attach positive and negative cables (4) to battery (3).

CAUTION

Do not over tighten hold down bolts. Over tightening can distort or crack the battery case.

- c. Tighten hold down bolts on cables (4).
- d. Replace battery box cover (1).
- e. Turn battery charger circuit breaker ON. Remove tag.

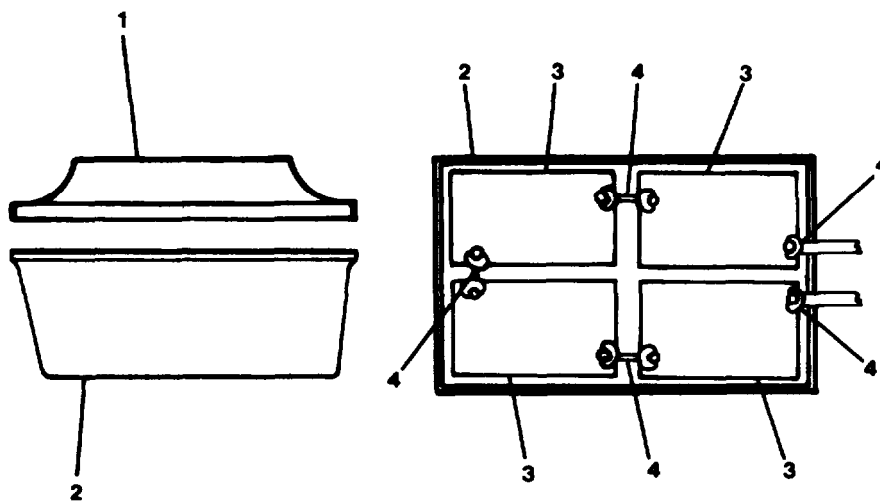


FIGURE 2-163. Battery Removal/Replacement

---

2-195. Replace/Repair Emergency Switchboard Battery Charger.

---

This task covers: a. Removal, b. Disassembly, c. Repair,  
d. Assembly, e. Replacement.

---

### INITIAL SETUP

#### Tools

Tool kit, electrician's,  
5180-00-391-1087

#### Materials/Parts

Circuit breaker P/N P4-WOC-35A2  
Cartridge fuse P/N P8-C2-B35  
Warning tag, Item 1, Appendix C

#### Equipment Condition

EMER SWBD BATT CHGR EP110 40AT  
circuit breaker OFF and tagged  
"Out of Service - Do Not Operate."  
TM 55-1905-223-10.

---

### WARNING

**Death, serious injury, or equipment damage can result from contact with live electrical circuits. Before beginning work on this, or any other electrical equipment, turn power and control voltage circuit breakers OFF and tag "Out of Service - Do Not Operate."**

### REMOVAL (FIGURE 2-164)

- a. Tag and disconnect electrical cables (3, 4).
- b. Remove two top mounting bolts (2).
- c. Remove battery charger (1).

### DISASSEMBLY (FIGURE 2-165)

- a. Remove circuit breaker.
  - (1) Loosen door latch screw (2). Open door (1).
  - (2) Remove wiring and mounting screws from circuit breaker (6).
  - (3) Remove circuit breaker (6).

## **TM 55-1905-223-24-18-1**

- b. Remove cartridge fuses.
  - (1) Loosen door latch screw (2). Open door (1).
  - (2) Pull fuses (4, 5) straight out of fuseholder.

### **REPAIR** (FIGURE 2-165)

Repair of battery charge is by replacement of circuit breaker (6), and cartridge fuses (4, 5).

### **ASSEMBLY** (FIGURE 2-165)

- a. Replace cartridge fuses.
  - (1) Install fuses (4, 5) in fuseholder.
- b. Replace circuit breakers.
  - (1) Position circuit breaker (6).
  - (2) Attach mounting screws and wiring.
  - (3) Close door (1).
  - (4) Tighten door latch screw (2).

### **REPLACEMENT** (FIGURE 2-164)

- a. Position battery charger (1).
- b. Secure with top mounting bolts (2).
- c. Connect electrical cables (3, 4).
- d. Turn emergency switchboard circuit breaker ON. Remove tag.



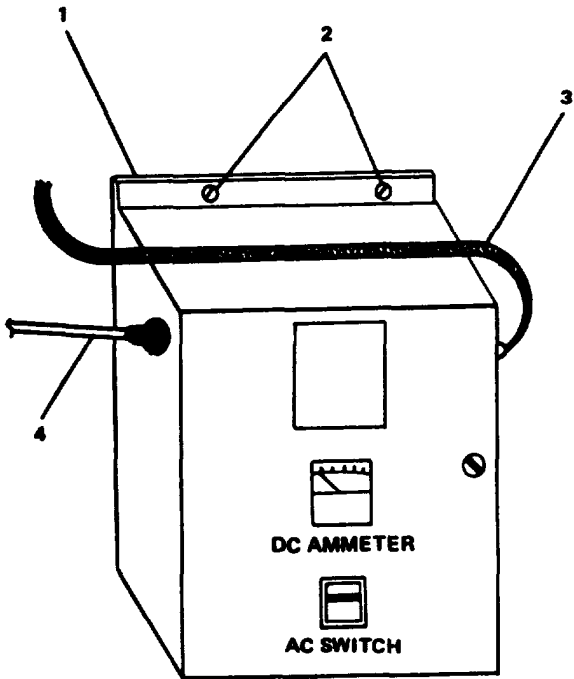


FIGURE 2-164. Battery Charger Removal.

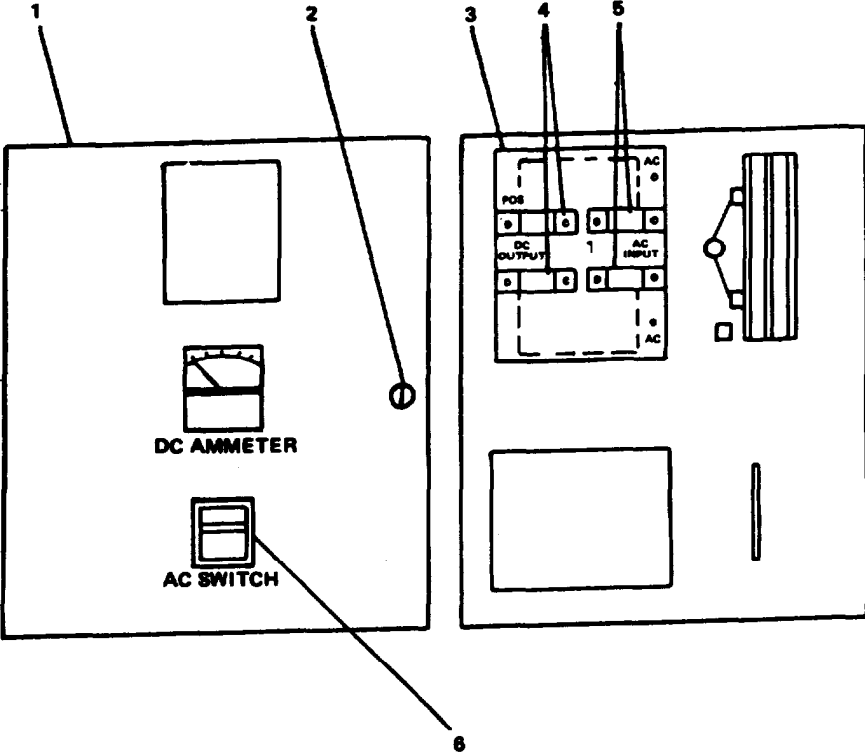


FIGURE 2-165. Battery Charger Repair.

2-196. Replace/Repair Pilot House Battery Assembly.

---

This task covers: a. Removal, b. Repair, c. Replacement.

---

INITIAL SETUP

Tools

Tool kit, electrician's,  
5180-00-391-1087

Materials/Parts

Battery P/N COM-5D  
Warning tag, Item 1, Appendix C

Equipment Condition

AN-VRC-80 BATT CHGR EP109 40AT  
circuit breaker OFF and tagged  
"Out of Service - Do Not Operate."  
TM 55-1905-223-10.

---

Refer to procedures in paragraph 2-194 for removal, repair and replacement of battery.

---

2-197. Replace/Repair Pilot House Battery Assembly Charger.

---

This task covers: a. Removal, b. Repair, c. Replacement.

---

INITIAL SETUP

Tools

Tool kit, electrician's,  
5180-00-391-1087

Equipment Condition

AN-VRC-80 BATT CHGR EP109 40AT  
circuit breaker OFF and tagged  
"Out of Service - Do Not Operate."  
TM 55-1905-223-10.

Materials/Parts

Circuit breaker P/N P4-WOC-35A2  
Cartridge fuse P/N P8-C2-B35  
Warning tag, Item 1, Appendix C

---

Refer to procedures in paragraph 2-195 to replace and repair the battery charger.

2-198. Replace/Repair Emergency Generator Battery Assembly.

---

This task covers: a. Removal, b. Repair, c. Replacement.

---

INITIAL SETUP

Tools

Tool kit, electrician's,  
5180-00-391-1087

Materials/Parts

Battery P/N COM-5D  
Warning tag, Item 1, Appendix C

Equipment Condition

EMERG SWBD BATT CHGR EP110 40AT  
circuit breaker OFF and tagged  
"Out of Service - Do Not Operate."  
TM 55-1905-223-10.

---

Refer to procedures in paragraph 2-194 for removal, repair and replacement of battery.

---

2-199. Replace/Repair Emergency Generator Battery Charger.

---

This task covers: a. Removal, b. Repair, c. Replacement.

---

INITIAL SETUP

Tools

Tool kit, electrician's,  
5180-00-391-1087

Equipment Condition

EMERG GEN BATT CHGR EP113 25AT  
circuit breaker OFF and tagged  
"Out of Service - Do Not Operate."  
TM 55-1905-223-10.

Materials/Parts

Circuit breaker P/N P4-WOC-35A2  
Cartridge fuse P/N PS-C2-B35  
Warning tag, Item 1, Appendix C

---

Refer to procedures in paragraph 2-195 to replace and repair the battery charger.

2-200. Replace/Repair Generator Number One Battery Assembly.

---

This task covers: a. Removal, b. Repair, c. Replacement.

---

INITIAL SETUP

Tools

Tool kit, electrician's,  
5180-00-391-1087

Materials/Parts

Battery P/N COM-5D  
Warning tag, Item 1, Appendix C

Equipment Condition

SSDG-2 BATT CHGR EP112 40AT  
circuit breaker OFF and tagged  
"Out of Service - Do Not Operate."  
TM 55-1905-223-10.

---

CAUTION

**The eight batteries in this bank are connected in parallel. Be sure to tag cables before removal so that they can be installed in the correct location. Maximum output voltage to the engine starter should not exceed 24 volts DC.**

Refer to procedures in paragraph 2-194 for removal, repair and replacement of battery.

---

2-201. Replace/Repair Generator Number One Battery Charger.

---

This task covers: a. Removal, b. Repair, c. Replacement.

---

INITIAL SETUP

Tools

Tool kit, electrician's,  
5180-00-391-1087

Materials/Parts

Circuit breaker P/N P4-WOC-80A2  
Cartridge fuse P/N P8-A1-A70  
Cartridge fuse P/N P8-A1-A130  
Warning tag, Item 1, Appendix C

Equipment Condition

SSDG-2 BATT CHGR EP112 40AT  
circuit breaker OFF and tagged  
"Out of Service - Do Not Operate."  
TM 55-1905-223-10.

---

Refer to procedures in paragraph 2-195 to replace and repair the battery charger.

2-202. Replace Bow Thruster Battery Assembly.

---

This task covers: a. Removal, b. Replacement.

---

INITIAL SETUP

Tools

Tool kit, electrician's,  
5180-00-391-1087

Materials/Parts

Battery P/N COM-5D  
Warning tag, Item 1, Appendix C

Equipment Condition

BOWTHRUSTER BATT CHGR EPIII 40AT  
circuit breaker OFF and tagged  
"Out of Service - Do Not Operate."  
TM 55-1905-223-10.

---

**CAUTION**

The eight batteries in this bank are connected in parallel. Be sure to tag cables before removal so that they can be installed in the correct location. Maximum output voltage to the engine starter should not exceed 24 volts DC.

Refer to procedures in paragraph 2-194 to replace the bow thruster battery.



2-203. Replace/Repair Bow Thruster Battery Charger.

This task covers: a. Removal, b. Repair, c. Replacement.

**INITIAL SETUP**

**Tools**

Tool kit, electrician's,  
5180-00-391-1087

**Equipment Condition**

BOWTHRUSTER BATT CHGR EP111 40AT  
circuit breaker OFF and tagged  
"Out of Service - Do Not Operate."  
TM 55-1905-223-10.

**Materials/Parts**

Circuit breaker P/N P4-WOC-35A2  
Cartridge fuse P/N P8-A1-A70  
Cartridge fuse P/N P8-C2-B60  
Cartridge fuse P/N P8-A1-A130  
Warning tag, Item 1, Appendix C

Refer to procedures in paragraph 2-195 to replace and repair the battery charger.

MAINTENANCE OF DOORS, HATCHES AND MANHOLES/WINDOWS GROUP

---

2-204. Replace/Repair Manhole (Bolted Plate, Raised). (FIGURE 2-166)

---

This task covers: a. Removal, b. Repair, d. Replacement.

---

INITIAL SETUP

Tools

Tool kit, general mechanic's,  
5180-00-699-5273

Materials/Parts

Refer to doors, hatches, and manholes/  
windows group P/N 8167011,  
TM 55-1905-223-24P

---

REMOVAL

- a. Remove nuts (3) and washers (2) from stud (4).
- b. Remove manhole cover (1) from closure.
- c. Remove gasket (5) from manhole cover.

REPAIR

Repair at this level of maintenance is by replacement of defective parts.

REPLACEMENT

- a. Install gasket (5) on manhole cover (1).
- b. Place manhole cover (1) on closure.
- c. Secure cover using washers (2) and nuts (3).

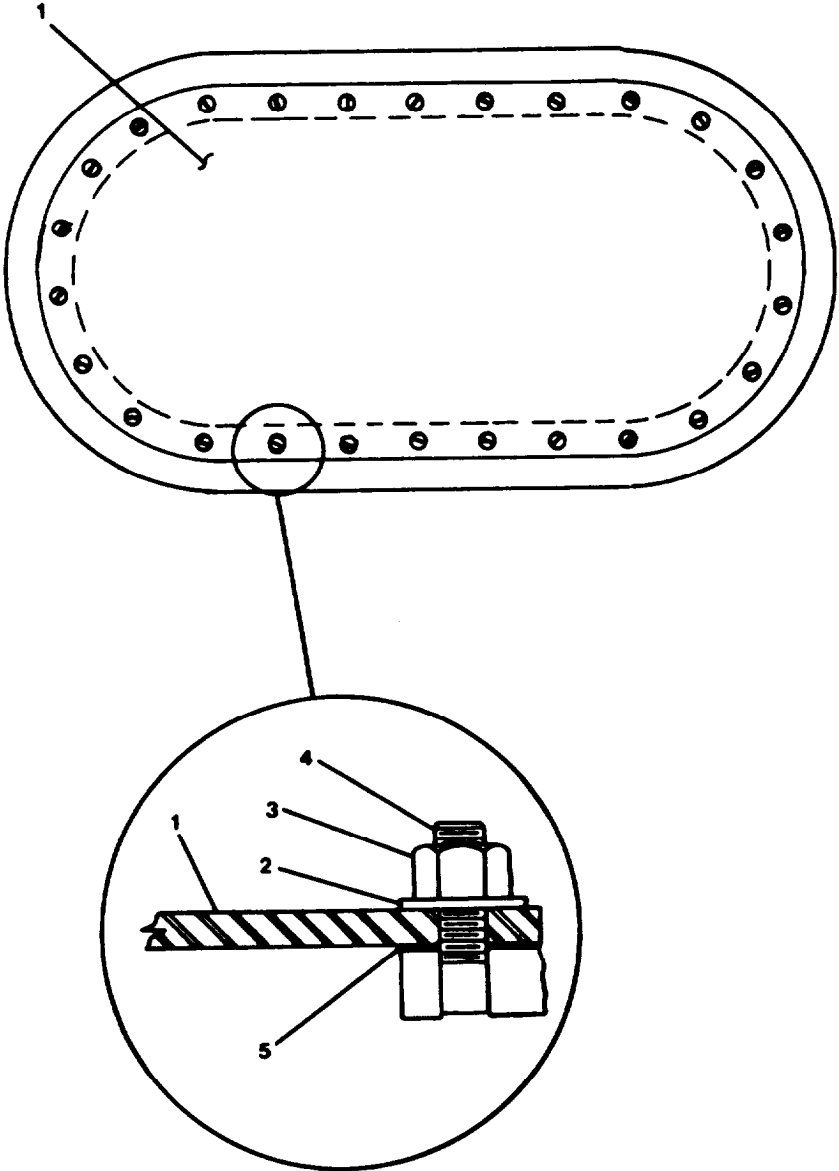


FIGURE 2-166. Replace Manhole (Bolted Plate. Raised).

2-205. Replace/Repair Manhole (Bolted Plate, Flush). (FIGURE 2-167)

---

This task covers: a. Removal, b. Repair, d. Replacement.

---

### INITIAL SETUP

#### Tools

Tool kit, general mechanic's,  
5180-00-699-5273

#### Materials/Parts

Refer to doors, hatches, and manholes/  
windows group P/N 8167011,  
TM 55-1905-223-24P

---

### REMOVAL

- a. Remove screws (2) from manhole cover (1).
- b. Remove manhole cover (1) from closure.
- c. Remove gasket (3) from manhole cover.

### REPAIR

Repair at this level of maintenance is by replacement of defective parts.

### REPLACEMENT

- a. Install gasket (3) on manhole cover (1).
- b. Place manhole cover (1) on closure.
- c. Install screws (2) on manhole cover.

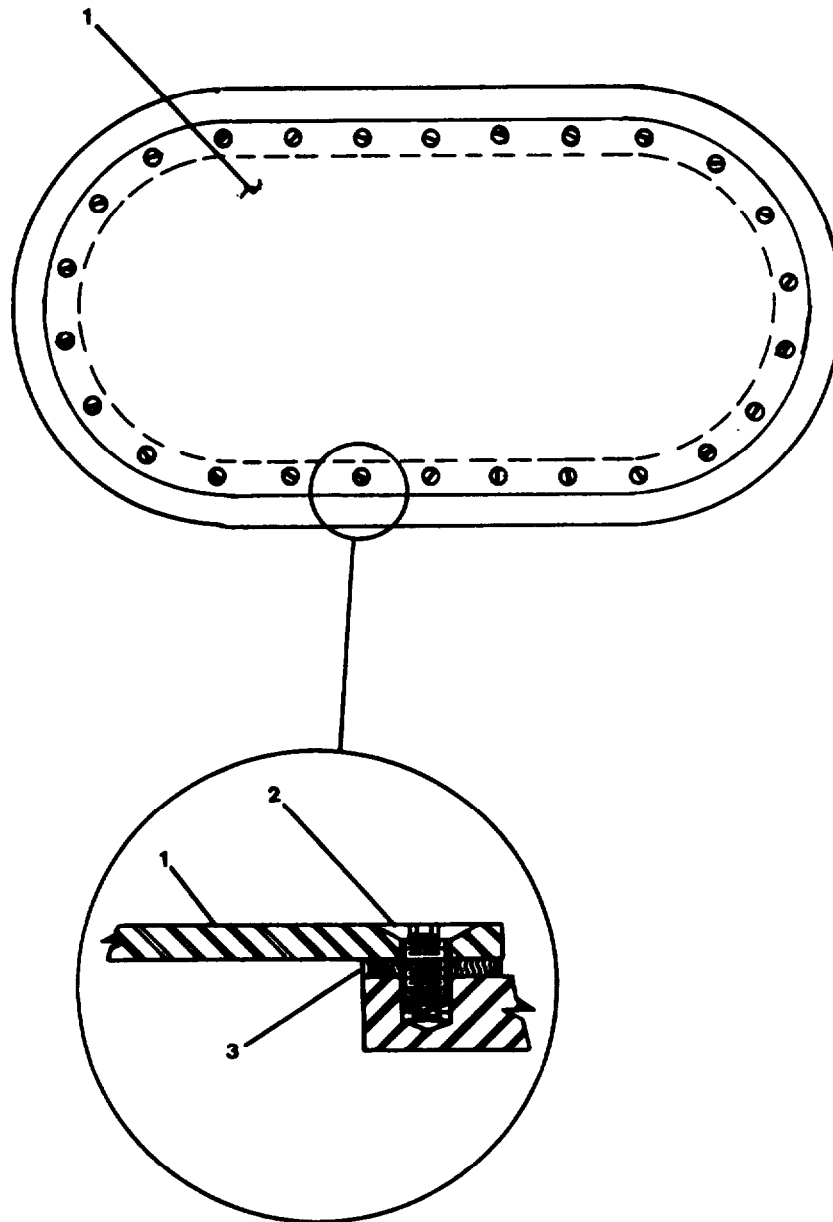


FIGURE 2-167. Replace Manhole (Bolted Plate, Flush).

2-206. Replace/Repair Watertight Doors, Four Dogs (30 x 51) (With Fixed Light).

---

This task covers: a. Removal, b. Disassembly, c. Repair, d. Assembly, e. Replacement.

---

### INITIAL SETUP

#### Tools

Tool kit, general mechanic's,  
5180-00-699-5273  
Torch outfit, cutting and welding  
medium duty, oxygen and  
acetylene, 3433-00-357-8116  
Tool kit, welder, 5180-00-754-0661

#### Materials/Parts

Gasket P/N DWG9PC7  
Preformed packing P/N DWG9PC13  
Bushing (oilite bronze) P/N DWG9PC6  
Marking chalk, (Item 35, Appendix C)

---

### REMOVAL

#### WARNING

Doors weigh approximately 100 pounds. To prevent personal injury at least two soldiers should handle door.

#### **NOTE**

Removal/replacement procedures for both left and right hand doors are the same.

- a. Remove (if installed) grounding straps (6, FIGURE 2-168) from hinge blades (2) and from bulkhead.
- b. Open door (1).

#### **NOTE**

When loosening dogs in watertight doors, those dogs nearest the hinges should be loosened first. This prevents the door from springing and makes it easier to operate the remaining dogs.

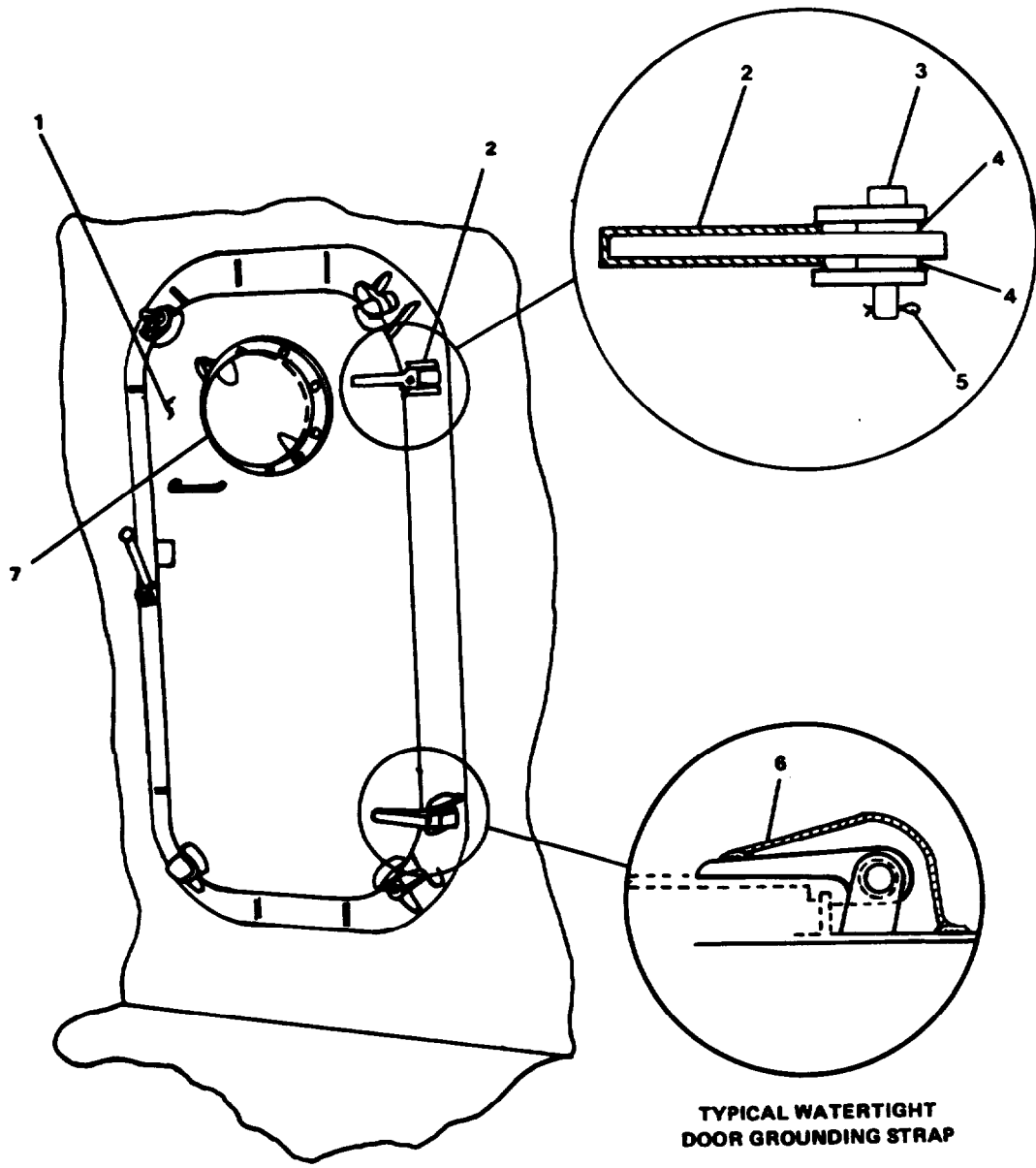


FIGURE 2-168 Replace Waternight Door Four Dogs (30 X 51)  
(With Fixed Light).

- c. Remove cotter pins (5) from cylindrical pins (3).
- d. Remove cylindrical pins (3) from hinge blades (2).
- e. Remove flat washers (4) then remove door (1).

## DISASSEMBLY

### **NOTE**

Disassembly/assembly procedures for both left and right hand doors are the same.

- a. Remove hex nuts (6, FIGURE 2-169) and handles (7) from door (1).
- b. Remove bronze bushing (5) and preformed packing (4) from door.
- c. Remove dog door closer (9) from door.

### **NOTE**

Refer to TM 55-1900-204-24 for detailed cutting and welding procedures,

- d. Remove pipe sleeve (8) from door.
- e. Remove gasket retainer (10) and gasket (11) from door.
- f. Clean gasket channel thoroughly.

### **NOTE**

After removing the old gasket, the entire gasket channel should be thoroughly cleaned.

- g. Remove stops (2) and flanged plate (3) from door.
- h. Remove light assembly (12) from door.

## REPAIR

Repair at this level of maintenance is by replacement of: gasket (11), preformed packing (4), oilite bronze bushings (5), fixed light assembly (12) and defective structural parts of the door.

## ASSEMBLY

- a. Install flanged plate (3) and stops (2) on door (1).
- b. Measure the required length around the door for the gasket.
- c. Add one additional inch and cut gasket.



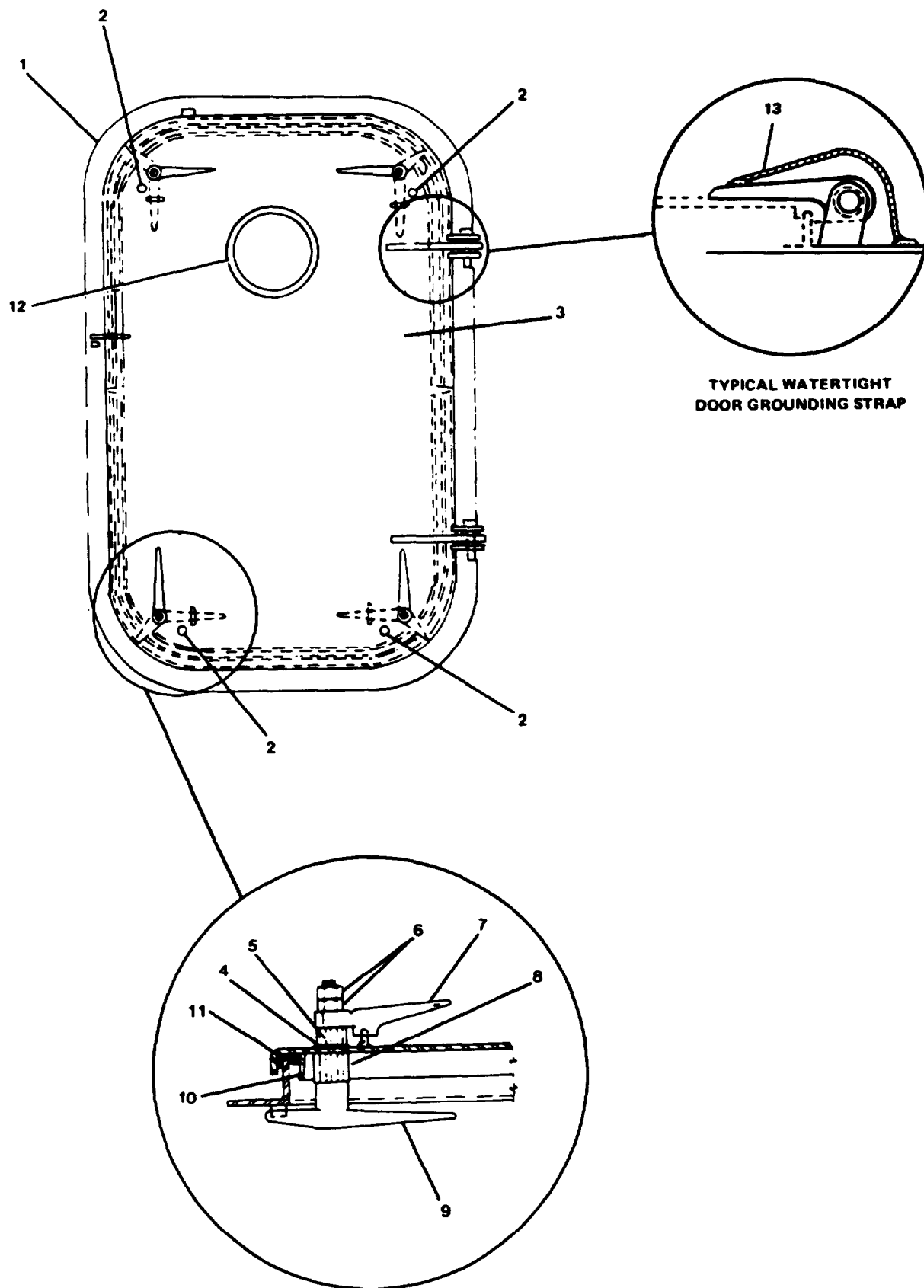


FIGURE 2-169. Repair Watertight Door, Four Dogs (30 x 51)  
With Fixed Light).

**NOTE**

If the gasket is shorter it will eventually shrink, leaving a gap at the joint and destroying the watertight integrity of the door.

- d. Install gasket (11) and gasket retainer (10) on door.
- e. Install pipe sleeve (8) on door.
- f. Install dog door closer (9) on door.
- g. Install preformed packing (4) and bronze bushings (5) on door.
- h. Install handles (7) on door.
- i. Secure handles using hex nuts (6).
- j. Install fixed light assembly (12) on door.

**REPLACEMENT**

- a. Place door (1, FIGURE 2-168) in position on frame.
- b. Install flat washers (4) and align holes.

**NOTE**

Make sure that one washer is placed on each side of hinge blade.

- c. Insert cylindrical pins (3) in hinge blades (2).
- d. Secure cylindrical pins (3) using cotter pins (5).

**NOTE**

Upon initial installation of a door, new gasket, or new dog, the door should be "chalk tested."

- e. Perform chalk test as follows:
  - (1) Clean the knife edge of the closure frame.
  - (2) Apply a chalk line completely around the knife edge of door frame.
  - (3) Dog the door.

**NOTE**

When setting up dogs on watertight doors. A dog on the opposite side from the hinges should be set up first with sufficient pressure to hold the door. Two dogs should then be set up snugly on the hinge side. Then all the dogs should be set up evenly to ensure a good bearing all around.

- (4) If the door is watertight, the gasket will show an unbroken chalk line.
- (5) If the line is broken, adjust the dogs and retest.

**CAUTION**

Dogs should not be adjusted to give more than 1/8" compression. Excessive pressure is harmful to the gasket.

- f. Operate door and check for smooth and positive dogging action.
- g. Install (if removed in step a of removal procedure) grounding straps (6, FIGURE 2-168) to hinge blades (2) and to bulkhead.

2-207. Replace/Repair Watertight Doors, Four Dogs (30 x 51)

---

This task covers: a. Removal, b. Disassembly, c. Repair, d. Assembly, e. Replacement.

---

INITIAL SETUP

Tools

Tool kit, general mechanic's,  
5180-00-699-5273  
Torch outfit, cutting and welding  
medium duty, oxygen and  
acetylene, 3433-00-357-8116  
Tool kit, welder, 5180-00-754-0661

Materials/Parts

Gasket P/N DWG9PC7  
Preformed packing P/N DWG9PC13  
Bushing (oilite bronze) P/N DWG9PC6  
Marking chalk, Item 35, Appendix C

---

REMOVAL

WARNING

Doors weigh approximately 100 pounds. To prevent personal injury at least two soldiers should handle door.

**NOTE**

Removal/replacement procedures for both left and right hand doors are the same.

- a. Remove (if installed) grounding straps (6, FIGURE 2-170) from hinge blades (2) and from bulkhead.
- b. Open door (1).

**NOTE**

When loosening dogs in watertight doors, those dogs nearest the hinges should be loosened first. This prevents the door from springing and makes it easier to operate the remaining dogs.

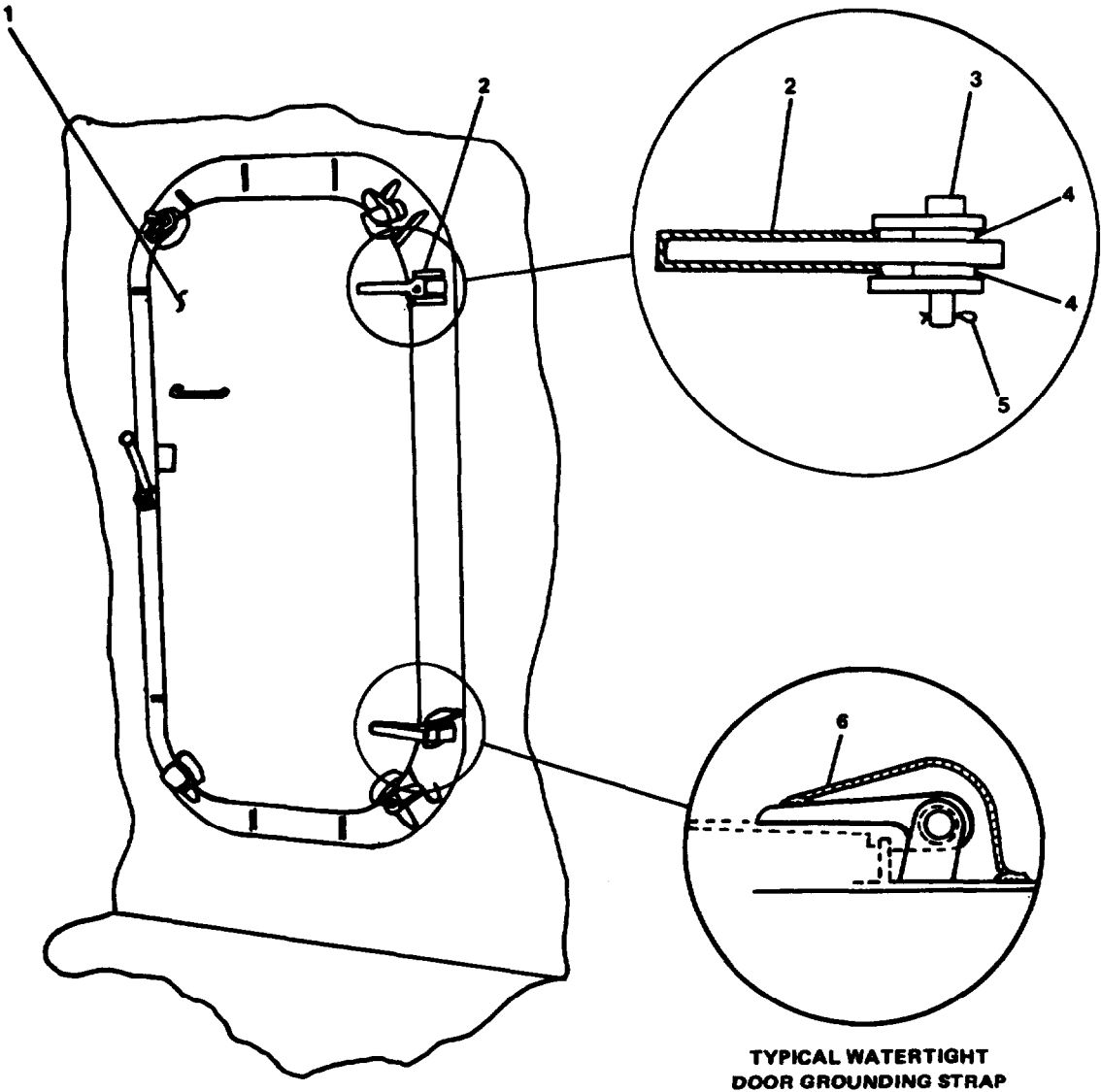


FIGURE 2-170. Replace Watertight Door. Four Dogs (30 x 51).

- c. Remove cotter pins (5) from cylindrical pins (3).
- d. Remove cylindrical pins (3) from hinge blades (2).
- e. Remove flat washers (4) then remove door (1).

## DISASSEMBLY

### NOTE

Disassembly/assembly procedures for both left and right hand doors are the same.

- a. Remove hex nuts (6, FIGURE 2-171) and handles (7) from door (1).
- b. Remove bronze bushing (5) and preformed packing (4) from door.
- c. Remove dog door closer (9) from door.

### NOTE

Refer to TM 55-1900-204-24 for detailed cutting and welding procedures.

- d. Remove pipe sleeve (8) from door.
- e. Remove gasket retainer (10) and gasket (11) from door.
- f. Clean gasket channel thoroughly.

### NOTE

After removing the old gasket, the entire gasket channel should be thoroughly cleaned.

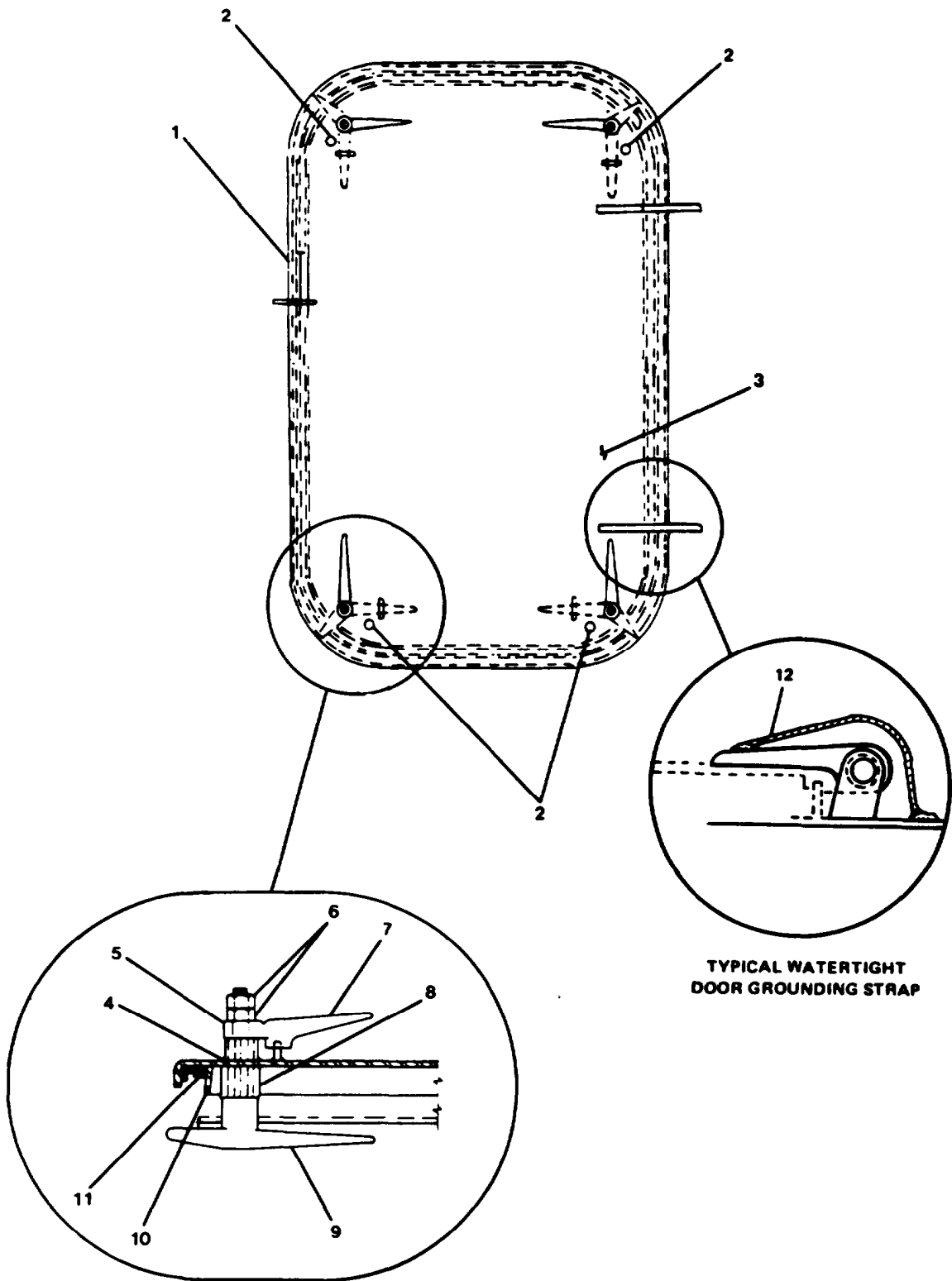
- g. Remove stops (2) and flanged plate (3) from door.

## REPAIR

Repair at this level of maintenance is by replacement of: gasket (11), preformed packing (4), oilite bronze bushings (5), and defective structural parts of the door.

## ASSEMBLY

- a. Install flanged plate (3) and stops (2) on door (1).
- b. Measure the required length around the door for the gasket,
- c. Add one additional inch for each 36 inches of channel and cut gasket.



TYPICAL WATERTIGHT  
DOOR GROUNDING STRAP

**FIGURE 2-171. Repair Watertight Door. Four Dogs (30 x 51).**

**NOTE**

If the gasket is shorter it will eventually shrink, leaving a gap at the joint and destroying the watertight integrity of the door.

- d. Install gasket (11) and gasket retainer (10) on door.
- e. Install pipe sleeve (8) on door.
- f. Install dog door closer (9) on door.
- g. Install preformed packing (4) and bronze bushings (5) on door.
- h. Install handles (7) on &or.
- i. Secure handles using hex nuts (6).

**REPLACEMENT**

- a. Place door (1, FIGURE 2-170) in position on frame.
- b. Install flat washers (4) and align holes.

**NOTE**

Make sure that one washer is placed on each side of hinge blade.

- c. Insert cylindrical pins (3) in hinge blades (2).
- d. Secure cylindrical pins (3) using cotter pins (5).

**NOTE**

Upon initial installation of a door, new gasket, or new dog the door should be "chalk tested."

- e. Perform chalk test as follows:
  - (1) Clean the knife edge of the closure frame.
  - (2) Apply a chalk line completely around the knife edge of door frame.
  - (3) Dog the door.



**NOTE**

When setting up dogs on watertight doors. A dog on the opposite side from the hinges should be set up first with sufficient pressure to hold the door. Two dogs should then be set up snugly on the hinge side. Then all the dogs should be set up evenly to ensure a good bearing all around.

- (4) If the door is watertight, the gasket will show an unbroken chalk line.
- (5) If the line is broken, adjust the dogs and retest.

**CAUTION**

Dogs should not be adjusted to give more than 1/8" compression. Excessive pressure is harmful to the gasket.

- f. Operate door and check for smooth and positive dogging action.
- g. Install (if removed in Step a of removal procedure) grounding straps (6, FIGURE 2-170) to hinge blades (2) and to bulkhead.

2-208. Replace/Repair Watertight Door, Quick Action, Left Hand (30 x 66).

---

This task covers: a. Removal, b. Disassembly, c. Repair, d. Assembly,  
e. Replacement.

---

### INITIAL SETUP

#### Tools

Tool kit, general mechanic's,  
5180-00-699-5273  
Torch outfit, cutting and welding  
medium duty, oxygen and  
acetylene, 3433-00-357-8116  
Tool kit, welder, 5180-00-754-0661

#### Materials/Parts

Bushing P/N DWG14PC28  
Preformed packing P/N DWG14PC13  
Helical compression spring  
P/N DWG14PC27  
Gasket P/N DWG14PC7  
Bushing (brass) P/N DWG14PC21  
Marking chalk, Item 35, Appendix C

---

### REMOVAL

#### WARNING

Door weighs approximately 100 pounds. To prevent personal injury at least two soldiers should handle door.

- a. Remove (if installed) grounding straps (6, FIGURE 2-172) from hinge blades (2) and from bulkhead.
- b. Open door (1).
- c. Remove cotter pins (5) from cylindrical pins (3).
- d. Remove cylindrical pins (3) from hinge blades (2).
- e. Remove flat washers (4) then remove door (1).

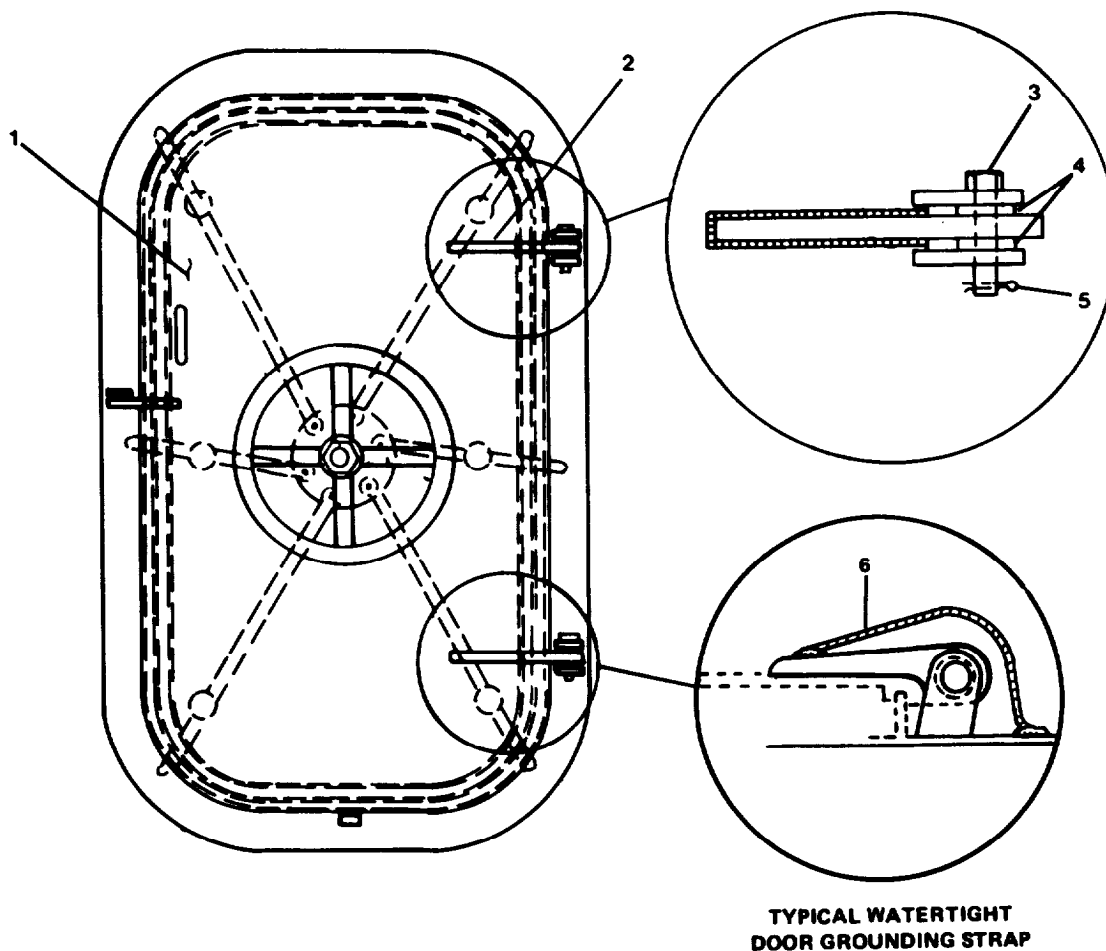


FIGURE 2-172. Replace Watertight Door, Quick Action, Left Hand (30 x 66).

### DISASSEMBLY

- a. Remove cotter pins (15, FIGURE 2-173) and cylindrical pins (11) from dog arms (2).
- b. Loosen setscrews (14) and remove dog arms (2) with guides (21) and bushings (4).
- c. Remove helical compression springs (6) from door (1).
- d. Remove hex nuts (9) and handwheel (7).
- e. Remove handwheel and shaft (17) from door.
- f. Remove shim (18), brass bushings (10), and preformed packing (8) from handwheel shaft (17).

### NOTE

Refer to TM 55-1900-204-24 for detailed cutting and welding procedures.

- g. Remove cover (16) and strap cover (20) from door.
- h. Remove pipe sleeve (19) from door.
- i. Remove coupling (12) from door.
- j. Remove gasket retainer (13) and gasket (5) from door.
- k. Clean gasket channel thoroughly.

**NOTE**

After removing the old gasket, the entire gasket channel should be thoroughly cleaned.

- l. Remove panel (3) from door.

**REPAIR**

Repair at this level of maintenance is by replacement of: preformed packing (8) gasket (5), brass bushings (10), helical compression springs (6), bushings (4) and defective structural parts of the door.

**ASSEMBLY**

- a. Install panel (3) on door (1).
- b. Measure the required length around the door for gasket.
- c. Add one additional inch for each 36 inches of channel and cut gasket.

**NOTE**

If the gasket is shorter it will eventually shrink, leaving a gap at the joint and destroying the watertight integrity of the door.

- d. Install gasket (5) and gasket retainer (13) on door.
- e. Install coupling (12) on door.
- f. Install pipe sleeve (19) on door.
- g. Install strap cover (20) and cover (16) on door.
- h. Install preformed packing (8), brass bushings (10), and shim (18) on handwheel shaft (17).
- i. Install handwheel and shaft (17) on door.
- j. Install handwheel (7) and secure with hex nuts (9).

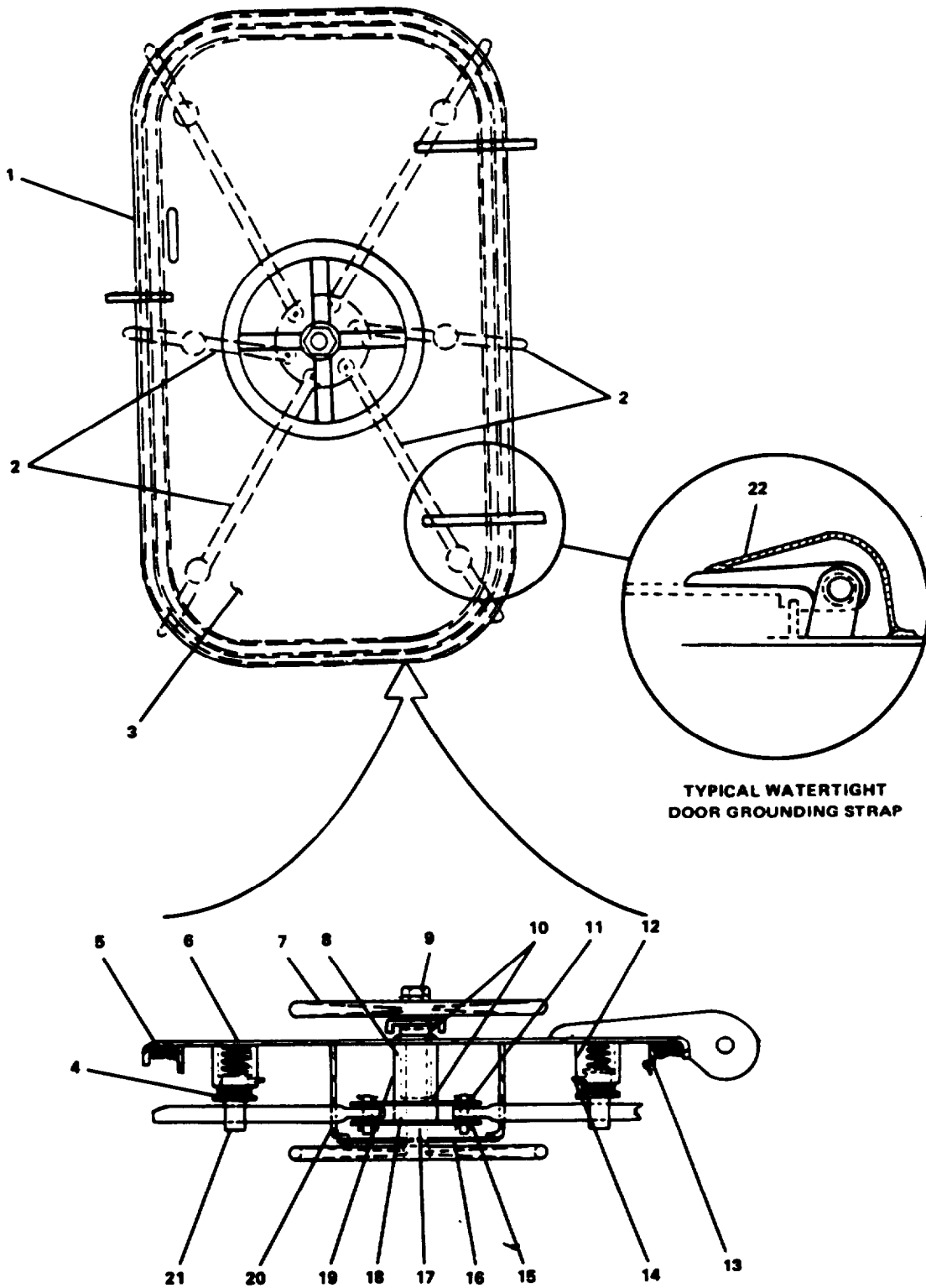


FIGURE 2-173. Repair Watertight Door, Quick Action, Left Hand (30 x 66).

- k. Place helical compression springs (6), then bushings (4) on door.
- l. Install dog arms (2) with guides (21) and secure using set screws (14).
- m. Install cylindrical pins in dog arms (2) and secure using cotter pins (15).

## **REPLACEMENT**

- a. Place door (1, FIGURE 2-172) in position on frame.
- b. Install flat washers (4) and align holes.

### **NOTE**

Make sure that one washer is placed on each side of hinge blade.

- c. Insert cylindrical pins (3) in hinge blades (2).
- d. Secure cylindrical pins (3) using cotter pins (5).

### **NOTE**

Upon initial installation of a door, new gasket, or new dog the door should be "chalk tested."

- e. Perform chalk test as follows:
  - (1) Clean the knife edge of the closure frame.
  - (2) Apply a chalk line completely around the knife edge of door frame.
  - (3) Dog the door.
  - (4) If the door is watertight, the gasket will show an unbroken chalk line,
  - (5) If the line is broken, adjust the dogs and retest.

### **CAUTION**

Dogs should not be adjusted to give more than 1/8" compression. Excessive pressure is harmful to the gasket.

- f. Operate door and check for smooth and positive dogging action.
- g. Install (if removed in step a of removal procedure) grounding straps (6, FIGURE 2-172) from hinge blades (2) and from bulkhead.

---

2-209. Replace/Repair Watertight Door, Six Dogs (30 x 60).

---

This task covers: a. Removal, b. Disassembly, c. Repair, d. Assembly, e. Replacement.

---

## INITIAL SETUP

### Tools

Tool kit, general mechanic's,  
5180-00-699-5273  
Torch outfit, cutting and welding  
medium duty, oxygen and  
acetylene, 3433-00-357-8116  
Tool kit, welder, 5180-00-754-0661

### Materials/Parts

Gasket P/N DWG10PC7  
Preformed packing P/N DWGI0PC13  
Bushing (oilite bronze) P/N DWGI0PC6  
Marking chalk, Item 35, Appendix C

---

## REMOVAL

### WARNING

Doors weigh approximately 100 pounds. To prevent personal injury at least two soldiers should handle door.

### NOTE

Removal/replacement procedures for both left and right hand doors are the same.

- a. Remove (if installed) grounding straps (6, FIGURE 2-174) from hinge blades (2) and from bulkhead.
- b. Open door (1).

### NOTE

When loosening dogs in watertight doors, those dogs nearest the hinges should be loosened first. This prevents the door from springing and makes it easier to operate the remaining dogs.

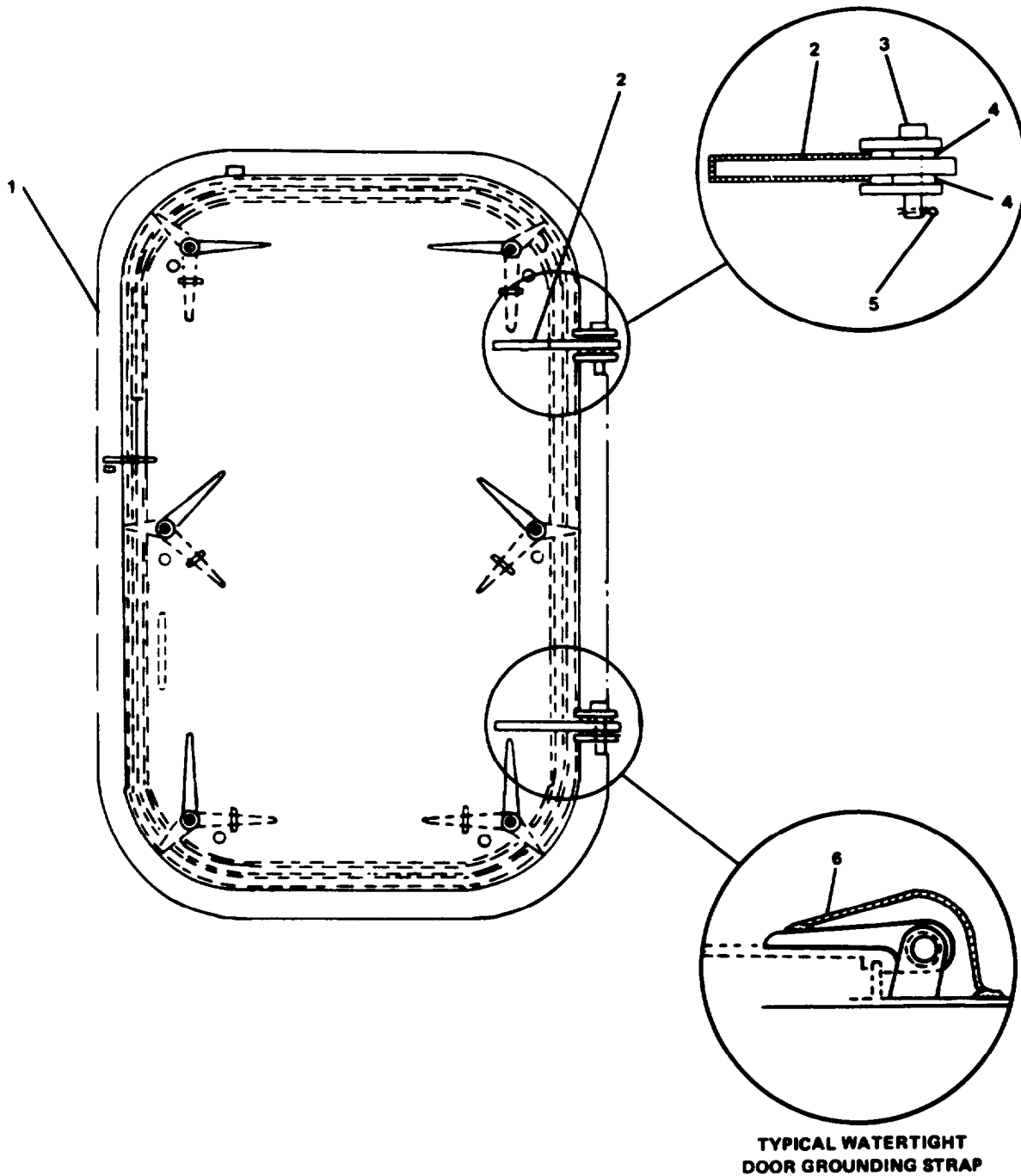


FIGURE 2-174. Replace Watertight Door, Six Dogs (30 x 60)



- c. Remove cotter pins (5) from cylindrical pins (3).
- d. Remove cylindrical pins (3) from hinge blades (2).
- a. Remove flat washers (4) then remove door (1).

## DISASSEMBLY

### NOTE

Disassembly/assembly procedures for both left and right hand doors are the same.

- a. Remove hex nuts (6, FIGURE 2-175) and handles (7) from door (1).
- b. Remove bronze bushing (5) and preformed packing (4) from door.
- c. Remove dog door closer (11) from door.

### NOTE

Refer to TM 55-1900-204-24 for detailed cutting and welding procedures.

- d. Remove shim (10) and pipe sleeve (9) from door.
- e. Remove gasket retainer (8) and gasket (12) from door.
- f. Clean gasket channel thoroughly.

### NOTE

After removing the old gasket, the entire gasket channel should be thoroughly cleaned.

- g. Remove stops (2) and flanged plate (3) from door.

## REPAIR

Repair at this level of maintenance is by replacement of: gasket (12), preformed packing (4), oilite bronze bushings (5), and defective structural parts of the door.

## ASSEMBLY

- a. Install flanged plate (3, FIGURE 2-175) and stops (2) on door (1).

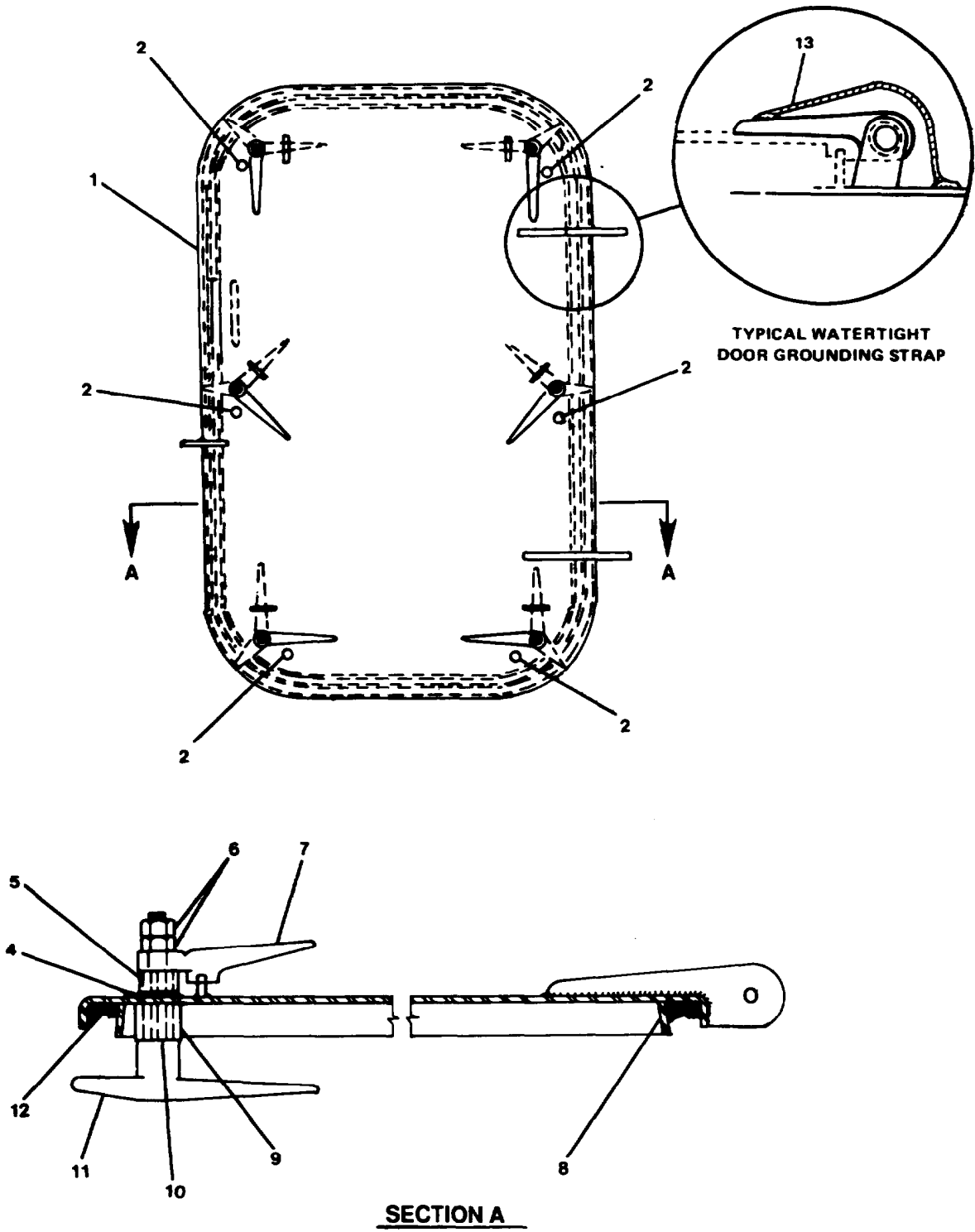


FIGURE 2-175. Repair Watertight Door, Six Dogs (30 x 60).

- b. Measure the required length around the door for the gasket.
- c. Add one additional inch and cut gasket.

**NOTE**

If the gasket is shorter it will eventually shrink, leaving a gap at the joint and destroying the watertight integrity of the door.

- d. Install gasket (12) and gasket retainer (8) on door.
- e. Install pipe sleeve (9) and shim (10) on door.
- f. Install dog door closer (11) on door.
- g. Install preformed packing (4) and bronze bushings (5) on door.
- h. Install handles (7) on door.
- i. Secure handles using hex nuts (6).

**REPLACEMENT**

- a. Place door (1, FIGURE 2-174) in position on frame.
- b. Install flat washers (4) and align holes.

**NOTE**

Make sure that one washer is placed on each side of hinge blade.

- c. Insert cylindrical pins (3) in hinge blades (2).
- d. Secure cylindrical pins (3) using cotter pins (5).

**NOTE**

Upon initial installation of a door, new gasket, or new dog the door should be "chalk tested."

- e. Perform chalk test as follows:
  - (1) Clean the knife edge of the closure frame.
  - (2) Apply a chalk line completely around the knife edge of door frame.
  - (3) Dog the door.

**NOTE**

When setting up dogs on watertight doors. A dog on the opposite side from the hinges should be set up first with sufficient pressure to hold the door. Two dogs should then be set up snugly on the hinge side. Then all the dogs should be set up evenly to ensure a good bearing all around.

- (4) If the door is watertight, the gasket will show an unbroken chalk line.
- (5) If the line is broken, adjust the dogs and retest.

**CAUTION**

Dogs should not be adjusted to give more than 1/8" compression. Excessive pressure is harmful to the gasket.

- f. Operate door and check for smooth and positive dogging action.
- g. Install (if removed in step a of removal procedure) grounding straps (6, FIGURE 2-174) from hinge blades (2) and from bulkhead.

---

2-210. Replace/Repair Watertight Door, Four Dogs (30 x 60).

---

This task covers: a. Removal, b. Disassembly, c. Repair, d. Assembly,  
e. Replacement.

---

### INITIAL SETUP

#### Tools

Tool kit, general mechanic's,  
5180-00-699-5273  
Torch outfit, cutting and welding  
medium duty, oxygen and acetylene,  
3433-00-357-8116  
Tool kit, welder, 5180-00-754-0661

#### Materials/Parts

Preformed packing P/N DWG9PC13  
Gasket P/N DWG9PC7  
Bushing (oilite bronze) P/N DWG9PC6  
Marking chalk, Item 35, Appendix C

---

### DISASSEMBLY

#### WARNING

Doors weigh approximately 100 pounds. To prevent personal injury at least two soldiers should handle door.

#### NOTE

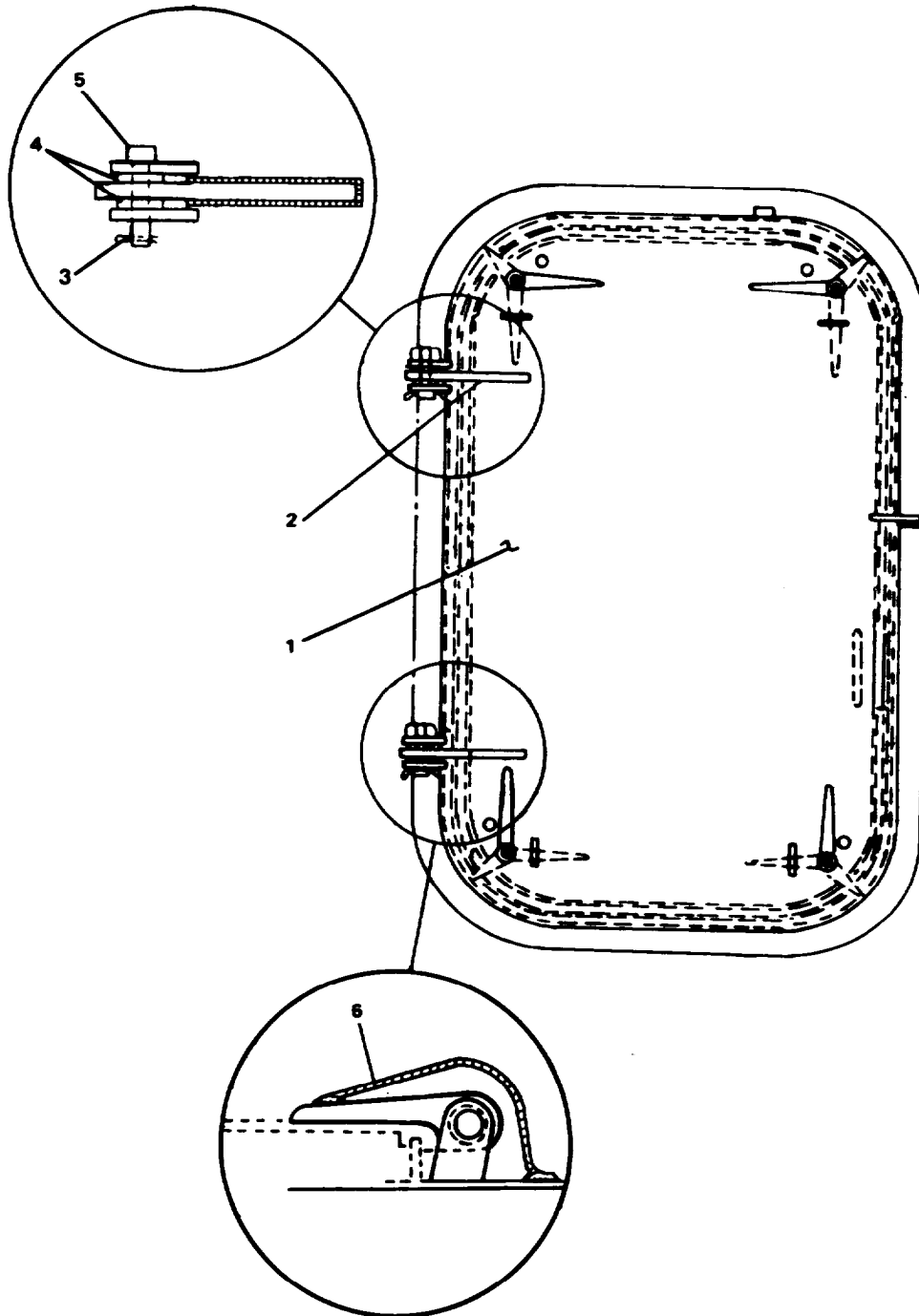
Removal/replacement procedures for both left and right hand doors are the same.

- a. Remove (if installed) grounding straps (6, FIGURE 2-176) from hinge blades (2) and from bulkhead.
- b. Open door (1).

#### NOTE

When loosening dogs in watertight doors, those dogs nearest the hinges should be loosened first. This prevents the door from springing and makes it easier to operate the remaining dogs.

- c. Remove cotter pins (3) from cylindrical pins (5).
- d. Remove cylindrical pins (5) from hinge blades (2).
- e. Remove flat washers (4) then remove door (1).



**TYPICAL WATERTIGHT  
DOOR GROUNDING STRAP**

FIGURE 2-176. Replace Watertight Door. Four Dogs (30 x 60).

**DISASSEMBLY****NOTE**

Disassembly/assembly procedures for both left and right hand doors are the same.

- a. Remove hex nuts (5, FIGURE 2-177) and handles (4) from door (1).
- b. Remove bronze bushings (6) and preformed packing (7) from door.
- c. Remove dog door closer (10) from door.

**NOTE**

Refer to TM 55-1900-204-24 for detailed cutting and welding procedures.

- d. Remove pipe sleeve (9) from door.
- e. Remove gasket (8) from door.
- f. Clean gasket channel thoroughly.

**NOTE**

After removing the old gasket, the entire gasket channel should be thoroughly cleaned.

- g. Remove stops (2) and flanged plate (3) from door.

**REPAIR**

Repair at this level of maintenance is by replacement of: gasket (8), preformed packing (7), oilite bronze bushings (6), and defective structural parts of the door.

**ASSEMBLY**

- a. Install flanged plate (3, FIGURE 2-177) and stops (2) on door (1).
- b. Measure the required length around the door for the gasket.
- c. Add one additional inch for each 36 inches of channel and cut gasket.

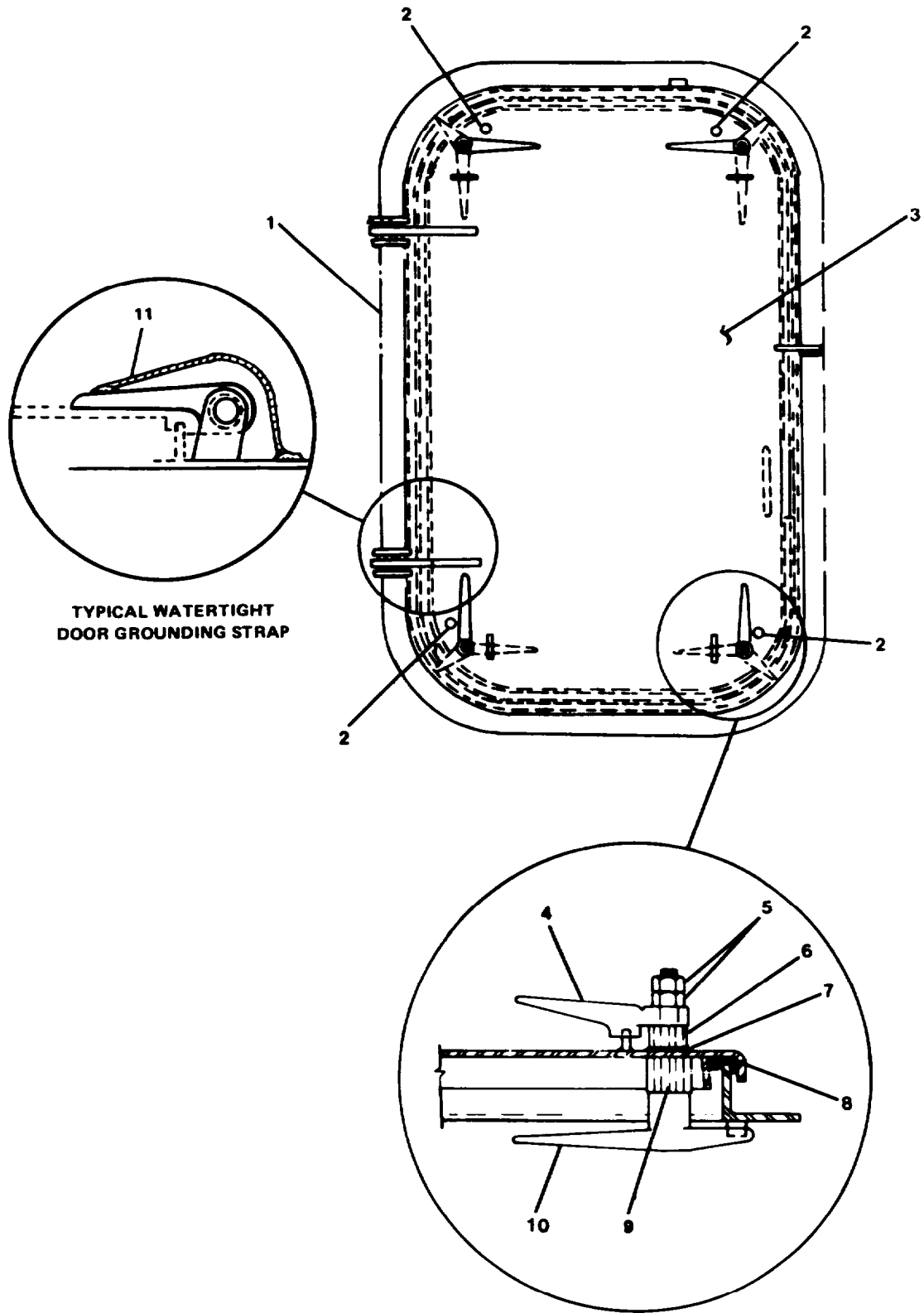


FIGURE 2-177. Repair Watertight Door, Four Dogs (30 x 60).



**NOTE**

If the gasket is shorter it will eventually shrink, leaving a gap at the joint and destroying the watertight integrity of the door.

- d. Install gasket (8) on door.
- e. Install pipe sleeve (9) on door.
- f. Install dog door closer (10) on door.
- g. Install preformed packing (7) and bronze bushings (6) on door.
- h. Install handles (4) on door.
- i. Secure handles using hex nuts (5).

**REPLACEMENT**

- a. Place door (1, FIGURE 2-176) in position on frame.
- b. Install flat washers (4) and align holes.

**NOTE**

Make sure that one washer is placed on each side of hinge blade.

- c. Insert cylindrical pins (5) in hinge blades (2).
- d. Secure cylindrical pins (5) using cotter pins (3).

**NOTE**

Upon initial installation of a door, new gasket, or new dog the door should be "chalk tested."

- e. Perform chalk test as follows:
  - (1) Clean the knife edge of the closure frame.
  - (2) Apply a chalk line completely around the knife edge of door frame.
  - (3) Dog the door.

**NOTE**

When setting up dogs on watertight doors. A dog on the opposite side from the hinges should be set up first with sufficient pressure to hold the door. Two dogs should then be set up snugly on the hinge side. Then all the dogs should be set up evenly to ensure a good bearing all around.

- (4) If the door is watertight, the gasket will show an unbroken chalk line.
- (5) If the line is broken, adjust the dogs and retest.

**CAUTION**

Dogs should not be adjusted to give more than 1/8" compression. Excessive pressure is harmful to the gasket.

- f. Operate door and check for smooth and positive dogging action.
- g. Install (if removed in step a of removal procedure) grounding straps (6, FIGURE 2-176) from hinge blades (2) and from bulkhead.

---

2-211. Replace/Repair Watertight Hatch, Quick Action.

---

This task covers: a. Removal, b. Disassembly, c. Repair, d. Assembly,  
e. Replacement.

---

## INITIAL SETUP

### Tools

Tool kit, general mechanic's,  
5180-00-699-5273  
Torch outfit, cutting and welding  
medium duty, oxygen and acetylene,  
3433-00-357-8116  
Tool kit, welder, 5180-00-754-0661

### Materials/Parts

Bushing (Delrin) P/N DWG32PC21  
Helical spring P/N DWG32PC26  
Preformed packing graphite  
P/N DWG32PC13  
Bushing (oilite bronze) P/N DWG32PC16  
Helical compression spring  
P/N DWG32PC17  
Gasket P/N DWG32PC7  
Marking chalk, Item 35, Appendix C

---

## DISASSEMBLY

### WARNING

Hatch is heavy. To prevent personal injury  
at least two soldiers should handle hatch.

- a. Open hatch (1, FIGURE 2-178).
- b. Remove cotter pins (5) from cylindrical pin (4).
- c. Remove cylindrical pin (4) and flat washers (3) from hinge (2).
- d. Remove hatch (1) from closure.

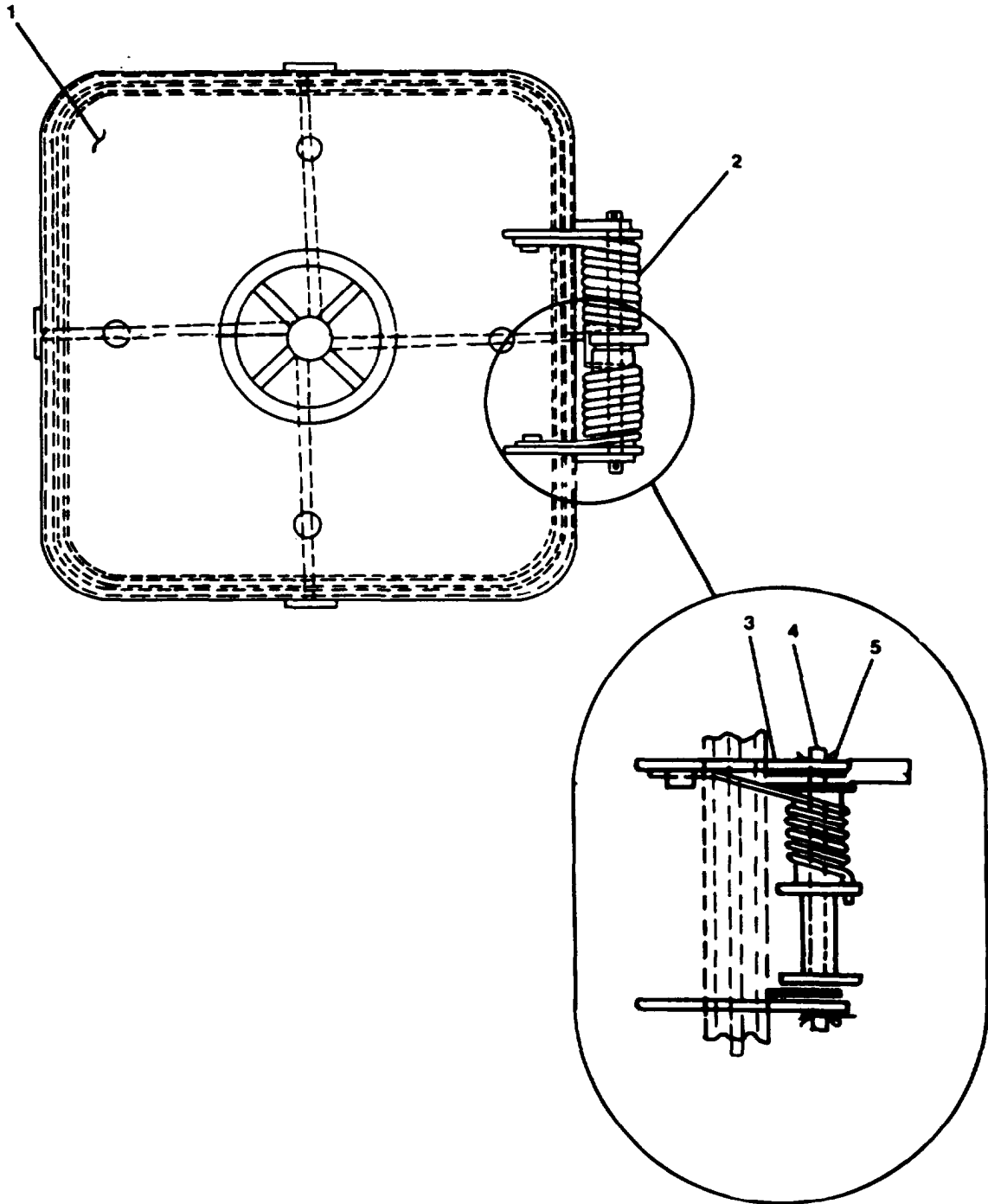


FIGURE 2-178. Replace Watertight HATCH, Quick Action.

---

**DISASSEMBLY**

- a. Remove helical compression spring (4, FIGURE 2-179) from hinge blade (2).
- b. Remove stop (3) from hatch (1).

**NOTE**

Refer to TM 55-1900-204-24 for detailed cutting and welding procedures.

- c. Remove sprocket (6) from hinge blade.
- d. Remove toggle (7) from hinge blade.
- e. Remove pipe sleeve (5) from hinge blade.
- f. Remove hexagon nuts (13) from handwheel (14).
- g. Remove handwheel (14), handwheel and shaft (19) from hatch.
- h. Remove delrin bushings (15) and preformed packing (11) from handwheel and shaft (19).
- i. Remove cover (18) from hatch (1).
- j. Remove cotter pins (16) from cylindrical pins (17).
- k. Remove cylindrical pins (17) from dog arms (24).
- l. Loosen set screws (22) and remove dog arms (24) with guides (23) and bronze bushing (25).
- m. Remove helical compression spring (9) from coupling (26), then remove coupling.
- n. Remove shim (20) and pipe sleeve (12) from hatch.
- o. Remove cover strap (21).
- p. Remove gasket retainer (8) and gasket (28) from hatch.
- q. Clean gasket channel thoroughly.

**NOTE**

After removing the old gasket, the entire gasket channel should be thoroughly cleaned.

- r. Remove coaming (27) and cover (10).

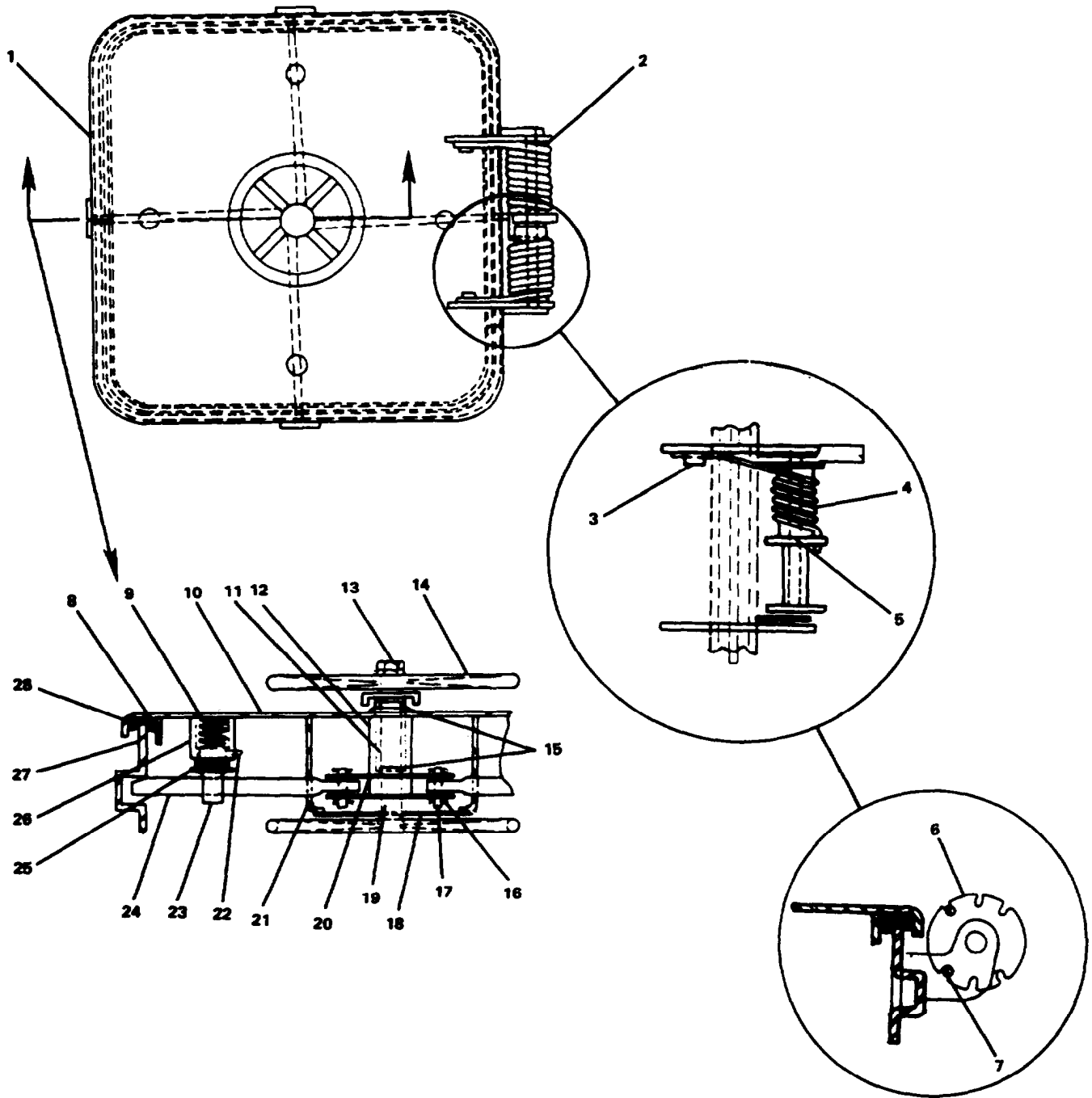


FIGURE 2-179. Repair Watertight Hatch, Quick Action.

REPAIR

Repair at this level of maintenance is by replacement of: delrin bushings (15), helical compression springs (4) and (9), preformed packing (11), bronze bushings (25), gasket (28), and defective structural parts of the hatch.

ASSEMBLY

- a. Install cover (10) and coaming (27) on hatch (1).
- b. Measure the required length around the hatch for gasket.
- c. Add one additional inch and cut gasket.

**NOTE**

If the gasket is shorter it will eventually shrink, leaving a gap at the joint and destroying the watertight integrity of the hatch.

- d. Install gasket (28) and gasket retainer (8) on hatch.
- e. Install cover strap (21).
- f. Install pipe sleeve (2) and shim (20) on hatch.
- g. Install coupling (26) and helical compression spring (9) on hatch.
- h. Place bronze bushings (25) in position, then install dog arms (24) with guides (23) on hatch.
- i. Tighten set screws (22).
- j. Install cylindrical pins (17) in dog arms (24).
- k. Secure cylindrical pins using cotter pins (16).
- l. Install cover (18) on hatch.
- m. Place preformed packing (11) and delrin bushings (15) on handwheel and shaft (19).
- n. Install handwheel and shaft (19) on hatch.
- o. Install handwheel (14) and secure using hexagon nuts (13).
- p. Install pipe sleeve (5) on hinge blade.
- q. Install toggle (7) and sprocket (6) on hinge blade.
- r. Install stop (3) on hatch (1), then install helical compression spring (4) on hinge blade.

**REPLACEMENT**

- a. Place hatch (1, FIGURE 2-178) in position on frame.
- b. Install flat washers (3) and align holes.

**NOTE**

Make sure that one washer is placed on each side of hinge blade.

- c. Insert cylindrical pin (4) in hinge (2).
- d. Secure cylindrical pin (4) using cotter pins (5).

**NOTE**

Upon initial installation of a hatch, new gasket, or new dog the hatch should be "chalk tested."

- e. Perform chalk test as follows:
  - (1) Clean the knife edge of the closure frame.
  - (2) Apply a chalk line completely around the knife edge of hatch frame.
  - (3) Dog the hatch.
  - (4) If the hatch is watertight, the gasket will show an unbroken chalk line.
  - (5) If the line is broken, adjust the dogs and retest.

**CAUTION**

Dogs should not be adjusted to give more than 1/8" compression. Excessive pressure is harmful to the gasket.

- f. Operate hatch and check for smooth and positive dogging action.



---

2-212. Replace/Repair Watertight Scuttle, Quick Action (Flush).

---

This task covers: a. Removal, b. Disassembly, c. Repair, d. Assembly.  
e. Replacement.

---

### INITIAL SETUP

#### Tools

Tool kit, general mechanic's,  
5180-00-699-5273  
Torch outfit, cutting and welding  
medium duty, oxygen and acetylene,  
3433-00-357-8116  
Tool kit, welder, 5180-00-754-0661

#### Materials/Parts

Gasket P/N DWG64PC9  
Bushing (oilite bronze) P/N DWG64PC17  
Preformed packing P/N DWG64PC18  
Bushing (steel) P/N DWG64PC26  
Helical compression spring  
P/N DWG64PC25  
Bushing (brass) P/N DWG64PC6

---

### REMOVAL

#### WARNING

Scuttle is heavy. To prevent personal injury at least two soldiers should handle scuttle.

- a. Open scuttle (1, FIGURE 2-180).
- b. Remove cylindrical pin (4) from hinge pad.
- c. Remove flat washers (2) from hinge pad.
- d. Remove brass bushings (3) from scuttle (1).
- e. Remove scuttle (1) from closure.

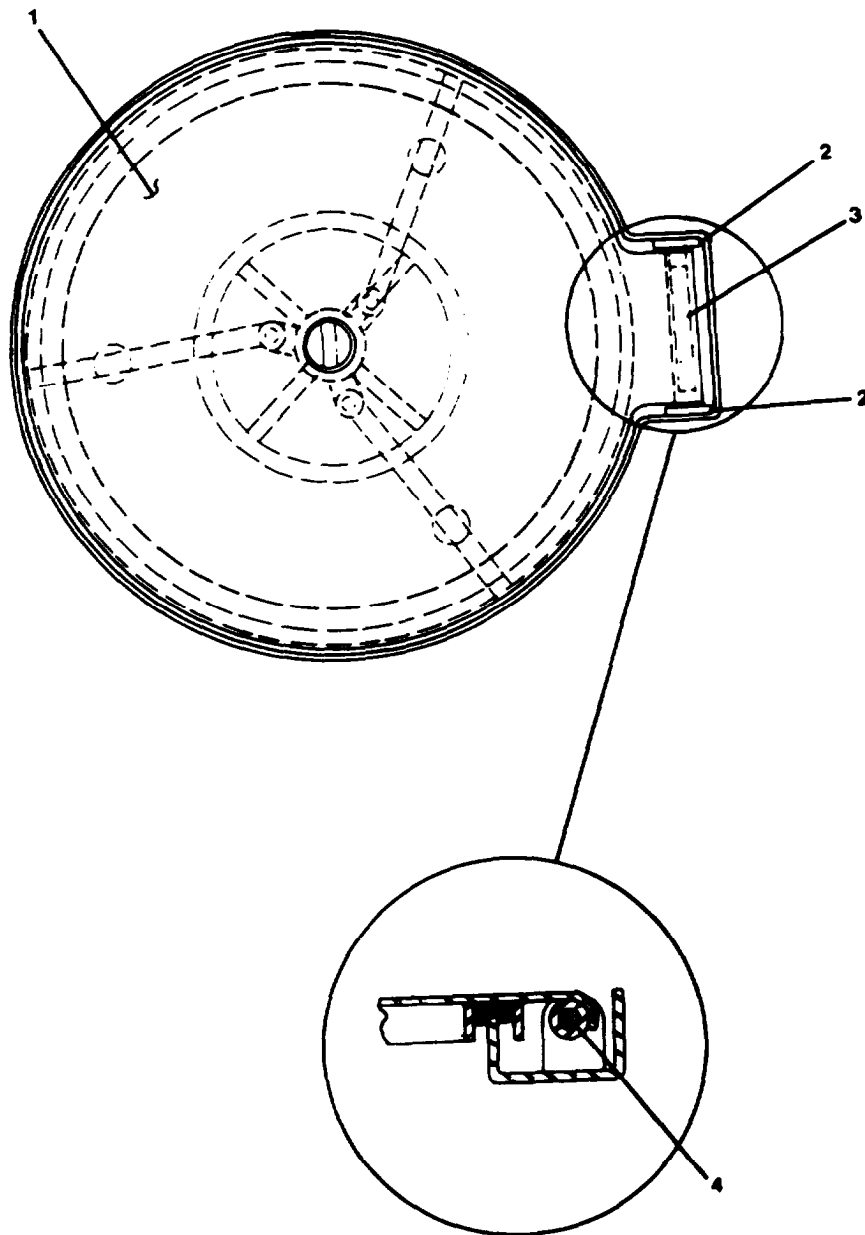


FIGURE 2-180. Replace Watertight Scuttle. Quick Action (Flush).

**DISASSEMBLY**

- a. Remove hexagon nuts (18, FIGURE 2-181) and handwheel (17) from scuttle (1).
- b. Remove cotter pins (16) from cylindrical pins (6), then remove cylindrical pins.
- c. Loosen set screws (20) and remove dog arms (23) from guides (21) from scuttle.
- d. Remove steel bushings (22) and springs (5) from scuttle.
- e. Remove spider (19) and shim (10) from scuttle.
- f. Remove bronze bushings (7) and preformed packing (9).
- g. Then remove dog stud (8) from scuttle.
- h. Remove gasket retainer (15) and gasket (14) from scuttle.
- i. Clean gasket channel thoroughly.

**NOTE**

After removing the old gasket, the entire gasket channel should be thoroughly cleaned.

- j. Remove pipe sleeve (11).

**NOTE**

Refer to TM 55-1900-204-24 for detailed cutting and welding procedures,

- k. Remove coupling (4) from scuttle.
- l. Remove sleeve (2) and stop (3) from scuttle.
- m. Remove flanged plate (13).

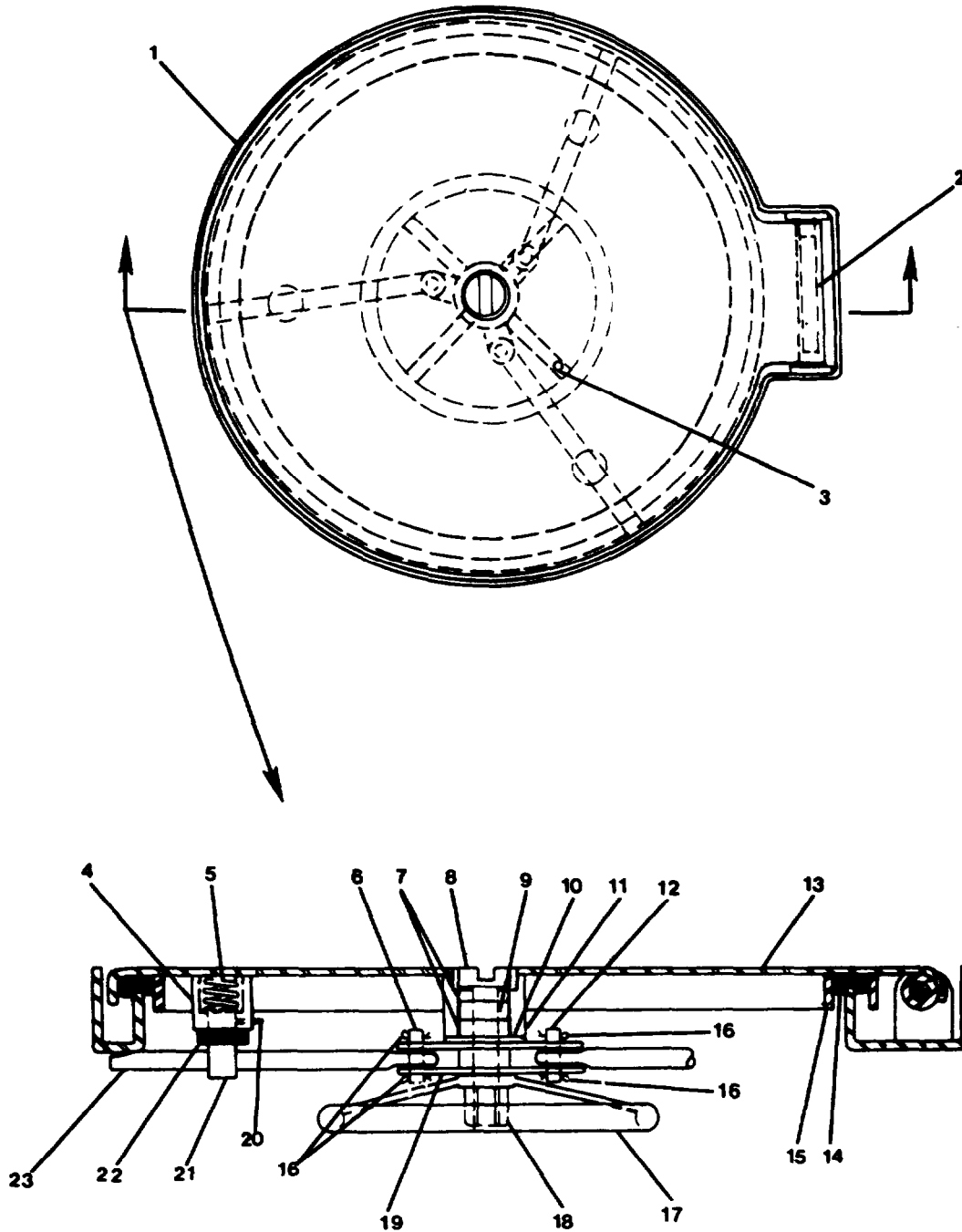


FIGURE 2-181. Repair Watertight Scuttle, Quick Action (Flush).

**REPAIR**

Repair at this level of maintenance is by replacement of: gasket (14), bronze bushings (7), preformed packing (9), brass bushings (3, FIGURE 2-151), steel bushings (22), helical compression springs (5), and defective structural parts of the scuttle.

**ASSEMBLY**

- a. Install flanged plate (13).
- b. Install stop (3) and sleeve (2) on scuttle (1).
- c. Install coupling (4) and pipe sleeve (11).
- d. Measure the required length around the scuttle for gasket.
- e. Add one additional inch and cut gasket.

**NOTE**

If the gasket is shorter it will eventually shrink, leaving a gap at the joint and destroying the watertight integrity of the scuttle.

- f. Install gasket (14) and gasket retainer (15) on scuttle.
- g. Install dog stud (8).
- h. Install preformed packing (9) and bronze bushings (7) on scuttle.
- i. Install shim (10) and spider (19).
- j. Place springs (5) and steel bushings (22) in position.
- k. Install guides (21) with dog arms (23) and tighten set screws (20).
- l. Install cylindrical pins (6) in dog arms.
- m. Secure cylindrical pins using cotter pins (16).
- n. Install handwheel (17) and secure using hexagon nuts (18).

**REPLACEMENT**

- a. Place scuttle (1, FIGURE 2-180) in position on closure.
- b. Install brass bushings (3) on scuttle (1).
- c. Install flat washers (4) on hinge pad and align holes.

**NOTE**

Make sure that one washer is placed on each side of hinge blade.

- d. Insert cylindrical pin (4) in hinge pad.

**NOTE**

Upon initial installation of a scuttle, new gasket, or new dog the hatch should be "chalk tested."

- e. Perform chalk test as follows:

- (1) Clean the knife edge of the closure frame.
- (2) Apply a chalk line completely around the knife edge of scuttle frame.
- (3) Dog the scuttle.
- (4) If the scuttle is watertight, the gasket will show an unbroken chalk line
- (5) If the line is broken, adjust the dogs and retest.

**CAUTION**

Dogs should not be adjusted to give more than 1/8" compression. Excessive pressure is harmful to the gasket.

- f. Operate scuttle and check for smooth and positive dogging action.

---

2-213. Replace/Repair Watertight Scuttle, Quick Action (Raised).

---

This task covers: a. Removal, b. Disassembly, c. Repair, d. Assembly,  
e. Replacement.

---

### INITIAL SETUP

#### Tools

Tool kit, general mechanic's,  
5180-00-699-5273  
Torch outfit, cutting and welding  
medium duty, oxygen and acetylene,  
3433-00-357-8116  
Tool kit, welder, 5180-00-754-0661

#### Materials/Parts

Bushing (oilite bronze) P/N DWG65PC17  
Preformed packing (graphite)  
P/N DWG65PC16  
Spring, helical compression  
P/N DWG65PC26  
Gasket P/N DWG65PC8  
Marking chalk, Item 35, Appendix C

---

### REMOVAL

#### WARNING

Scuttle is heavy. To prevent personal injury at least two soldiers should handle.

- a. Open scuttle (1, FIGURE 2-182).
- b. Remove cotter pins (4) from cylindrical pin(3).
- c. Remove cylindrical pin (3) from hinge blades.
- d. Remove flat washers (2).
- e. Remove scuttle (1) from closure.

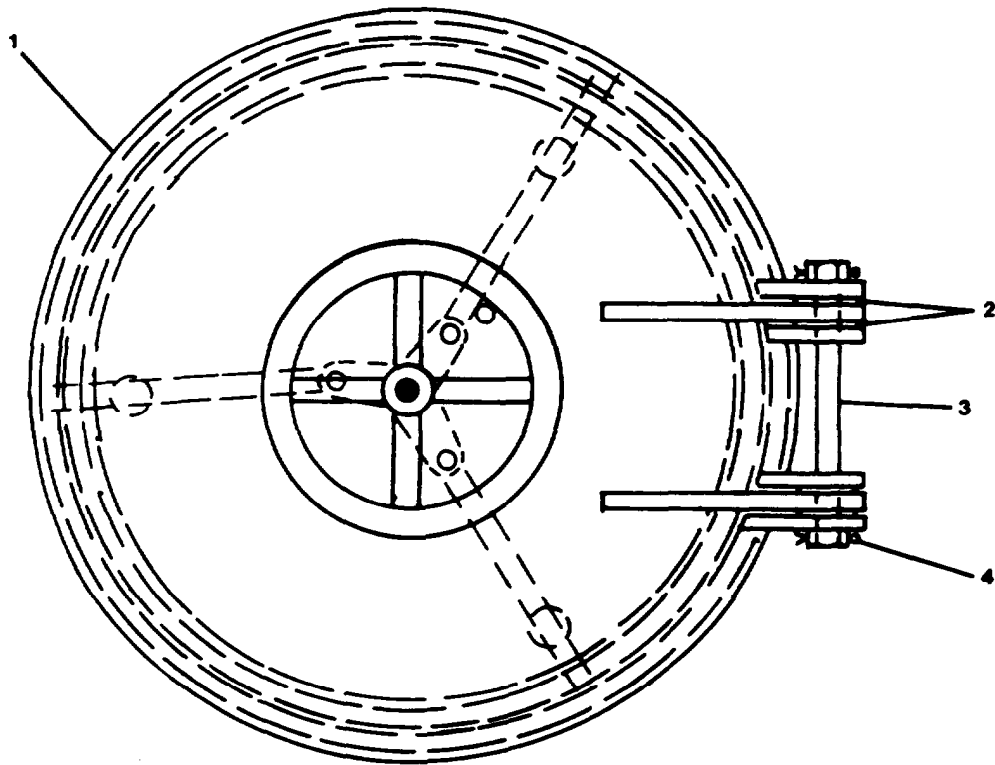


FIGURE 2-182. Remove Watertight Scuttle, Quick Action (Raised).



**DISASSEMBLY**

- a. Remove jam nuts (7, FIGURE 2-183) and handwheel (8) from scuttle (1).
- b. Remove handwheel and shaft (17).
- c. Remove cover (15) from scuttle.
- d. Remove cotter pins (13) from cylindrical pins (11).
- e. Remove cylindrical pins (11) from dog arms (12).
- f. Loosen set screws (14), remove dog arms (12) with guides (20), and helical compression springs (5).
- g. Remove spider (16) and flat washer (18) from scuttle.
- h. Remove bronze bushings (6) and preformed packing (9) from handwheel shaft (17).

**NOTE**

Refer to TM 55-1900-204-24 for detailed cutting and welding procedures.

- i. Remove cover strap (19) and pipe sleeve (10) from scuttle.
- j. Remove gasket retainer (4) and gasket (3) from scuttle.
- k. Clean gasket channel thoroughly.

**NOTE**

After removing the old gasket, the entire gasket channel should be thoroughly cleaned.

- l. Remove coupling (21) from scuttle.
- m. Remove stop (2), cover (23) and dog pocket (22) from scuttle.

**REPAIR**

Repair at this level of maintenance is by replacement of: gasket (4), helical compression springs (5), preformed packing (9), bronze bushings (6), and defective structural parts of the scuttle.

**ASSEMBLY**

- a. Install dog pocket (22), cover (23), and stop (2) on scuttle (1).
- b. Install coupling (21) on scuttle.

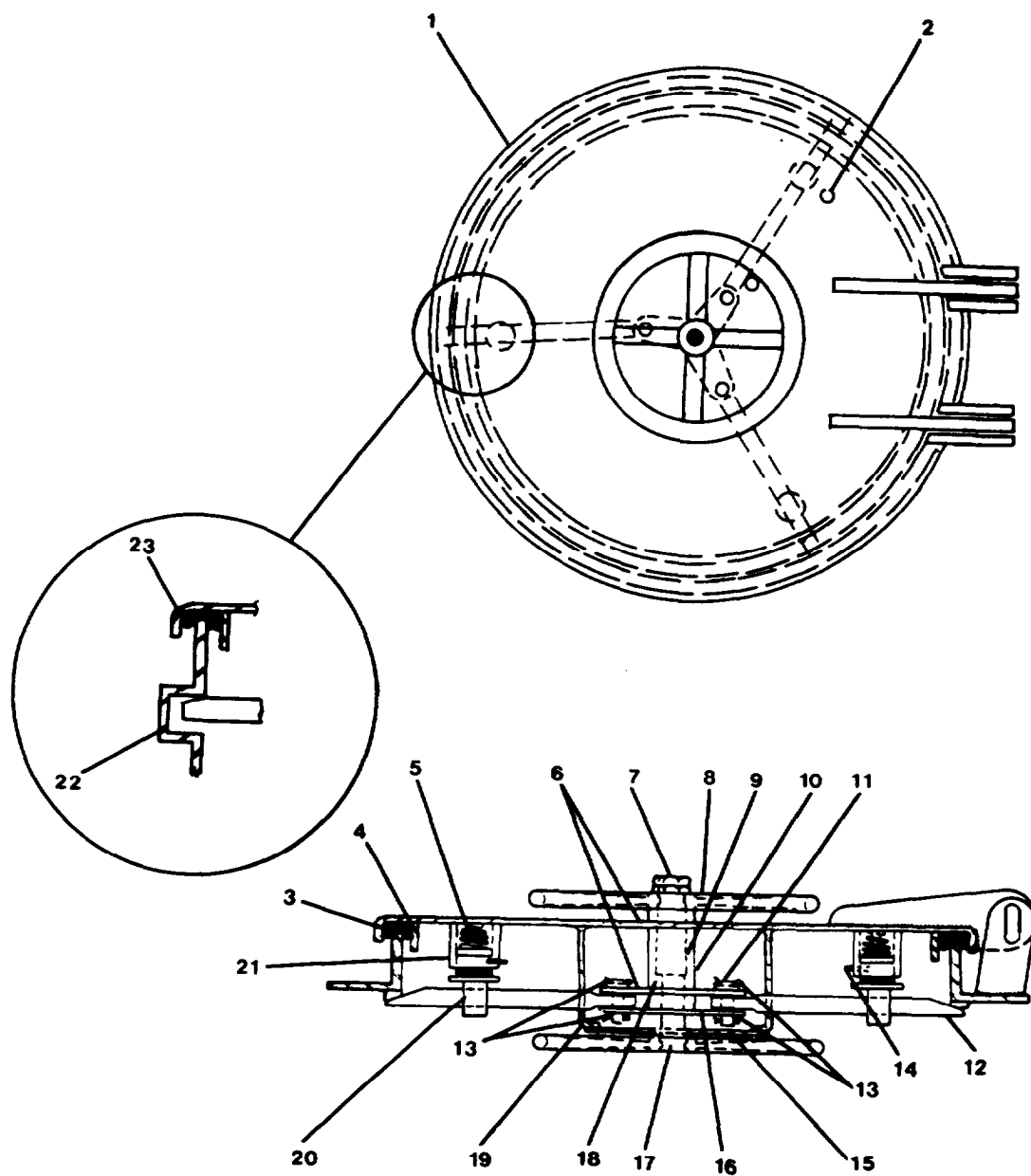


FIGURE 2-183. Repair Watertight Scuttle, Quick Action (Raised).

- c. Measure the required length around the scuttle for gasket.
- d. Add one additional inch and cut gasket.

**NOTE**

If the gasket is shorter it will eventually shrink, leaving a gap at the joint and destroying the watertight integrity of the scuttle.

- e. Install gasket (3) and gasket retainer (4) on scuttle.
- f. Install pipe sleeve (10) and cover strap (19) on scuttle.
- g. Place helical compression springs (5) in position.
- h. Install guides (20) with dog arms (12) and tighten set screws (14).
- i. Install cylindrical pins (11) in dog arms.
- j. Secure cylindrical pins using cotter pins (13).
- k. Place preformed packing (9) and bronze bushings (6) on handwheel shaft (17).
- l. Install flat washer (81) and spider (16) on scuttle.
- m. Install cover (15) on scuttle.
- n. Install handwheel and shaft (17).
- o. Install handwheel (8) on scuttle.
- p. Secure handwheel using jam nuts (7).

**REPLACEMENT**

- a. Place scuttle (1, FIGURE 2-182) in place.
- b. Install flat washers (2) and align holes.

**NOTE**

Make sure that one washer is placed on each side of hinge blade.

- c. Insert cylindrical pin (3) in hinge blades.
- d. Secure cylindrical pin (3) using cotter pins (4).

**NOTE**

Upon initial installation of a scuttle, new gasket, or new dog the scuttle should be "chalk tested."

- e. Perform chalk test as follows:
- (1) Clean the knife edge of the closure frame.
  - (2) Apply a chalk line completely around the knife edge of scuttle frame.
  - (3) Dog the scuttle.
  - (4) If the scuttle is watertight, the gasket will show an unbroken chalk line
  - (5) If the line is broken, adjust the dogs and retest.

**CAUTION**

Dogs should not be adjusted to give more than 1/8" compression. Excessive pressure is harmful to the gasket.

- f. Operate scuttle and check for smooth and positive dogging action.

This Page Intentionally Left Blank

MAINTENANCE OF LASHING GEAR EQUIPMENT

---

**2-214. Repair Lashing Gear. (FIGURE 2-184)**

---

This task covers: a. Disassembly, b. Repair, c. Assembly.

---

**INITIAL SETUP**

**Tools**

Tool kit, general mechanic's,  
5180-00-699-5273

---

**REMOVAL**

- a. Remove clamp (3).
- b. Remove toggle assembly (2) from head assembly (1).

**REPAIR**

Repair at this level of maintenance is by replacement of worn or defective parts.

**ASSEMBLY**

- a. Install toggle assembly (2) in head assembly (1).
- b. Install new clamp (3).

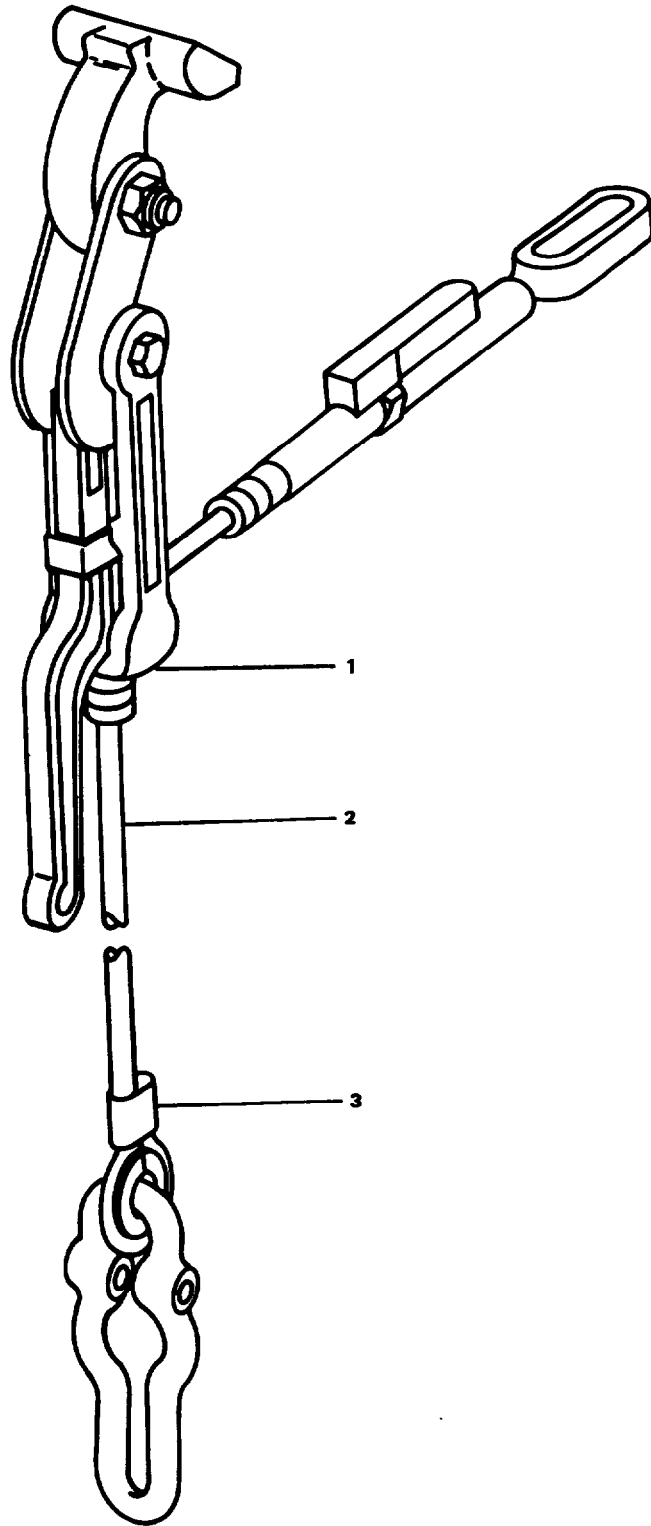


FIGURE 2-184. Lashing Gear.

MAINTENANCE OF WOREBOAT, LIFEBOATS/DAVITS
---

---

**2-215. Repair/Replace Inflatable Rat Boat. (FIGURE 2-185)**

---

This task covers: a. Removal, b. Disassembly, c. Repair, d. Assembly, e. Replacement.

---

**INITIAL SETUP**

**Tools**

Tool kit, general mechanic's,  
5180-00-699-5273

**Materials/Parts**

Inflatable workboat  
P/N 4 meter searider  
Boat repair kit P/N AV860

---

**REMOVAL**

- a. Disconnect the tie down lines to workboat.
- b. Use crane to lift workboat and swing over side to lower to pier. Refer to TM 55-1905-223-10 for crane operation.
- c. Disconnect hoist block and tackle.

**DISASSEMBLY**

- a. It is recommended that disassembly of the inflatable mat boat be limited to those components that would aid repair.



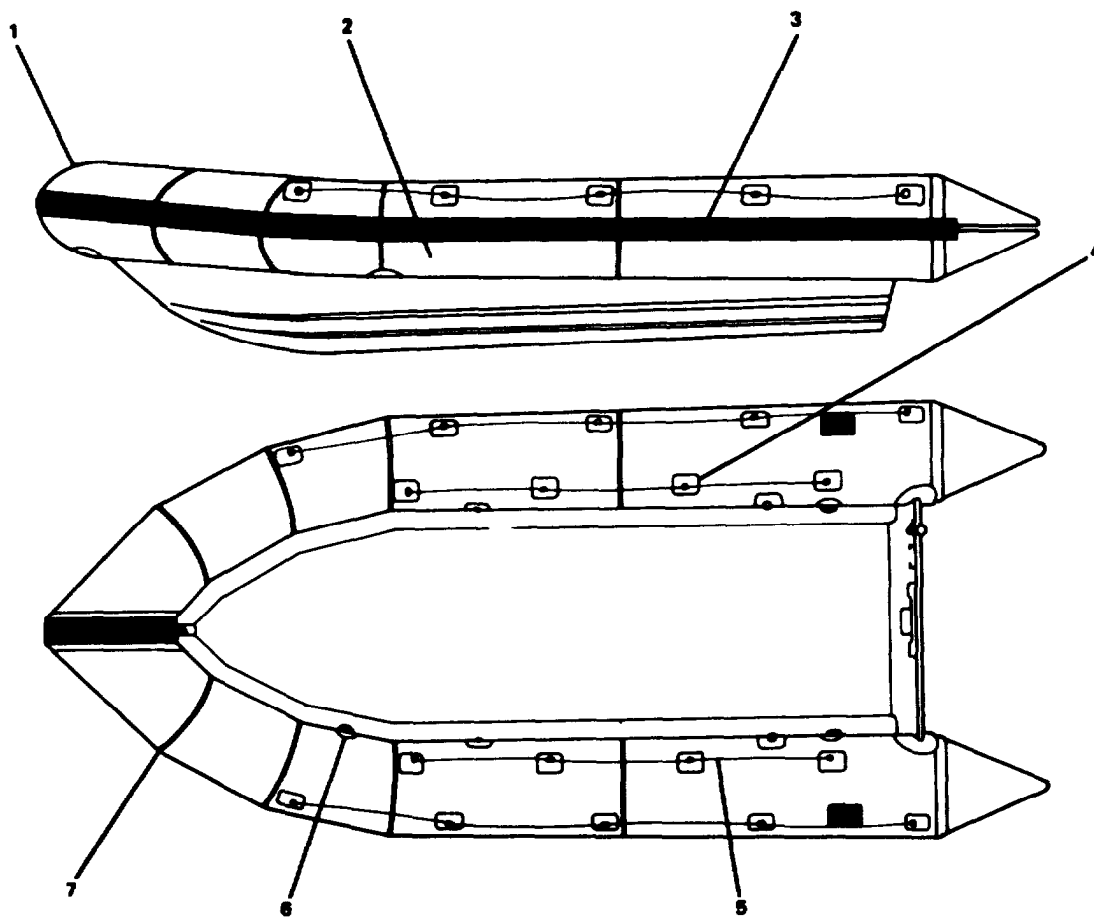


FIGURE 2-185. Inflatable Boat Repair.

## **REPAIR**

The Avon Repair Kit contains full instructions which should be followed carefully, these basically are:

Choose a suitable patch to overlap tear 1" (25 mm) all round. Clean patch and surface to be repaired thoroughly by means of abrasive paper. Surfaces must be completely dry before application of adhesive. Apply two coats of adhesive to the patch and surface to be repaired, allowing first coat to dry for 5 to 10 minutes before application of a second coat. When final coat is tacky (a further 5 to 10 minutes) apply patch and smooth out with a spatula-shaped tool. Work from the center to the outside to remove any trapped air and allow to dry. The repair should be left for at least 12 hours to cure before inflation of the tubes, except in an emergency when only a temporary repair is required.

Tears or punctures less than 2" (50 mm) can be repaired as above, but in excess of 2" (50 mm) in length the tear must be herringbone stitched before repair with strong thread. Difficult repairs (e.g., across a seam) and very long tears should be referred to more extensive facilities.

## **ASSEMBLY**

### **NOTE**

Use glue from repair kit to perform the following steps.

- a. Install grey seam tape (7).
- b. Install poly lifeline (5).
- c. Install valve (6).
- d. Install hypalon fabric (2).
- e. Install lifeline patch (4).
- f. Install gray rub strake (3).

## **REPLACEMENT**

- a. Connect hoist block and tackle.
- b. Lift workboat, using crane, from pier and position on deck.
- c. Connect and secure workboat with tie down lines.

---

**2-216. Repair/Replace Outboard Motor. (FIGURE 2-186)**

---

This task covers: a. Removal, b. Disassembly, c. Repair, d. Assembly, e. Replacement, f. Inspection.

---

**INITIAL SETUP****Tools**

Tool kit, general mechanic's,  
5180-00-699-5273  
Lifting sling P/N 3375958  
Torque wrench kit P/N 3377216

**Equipment Condition**

Motor removed from boat.

**Materials/Parts**

Outboard motor P/N 7-040211N  
Spark plug P/N 33-82372M  
Propeller assembly P/N 48-73134A4  
Fluid filter element P/N 35-11934M  
Engine fuel tank P/N 1225-1529A26

---

**REMOVAL**

- a. Disconnect fuel line (14) from motor.
- b. Use a lifting sling to support the engine and loosen mounting clamps.
- c. Lift engine from workboat transom.

**DISASSEMBLY**

- a. Remove cowling (1).
- b. Remove the spark plug wire.
- c. Remove the spark plug (11).
- d. Remove cotter pin (6) and nut (7).
- e. Remove propeller assembly (8).
- f. Unscrew filter cup (5) from filter base (3).
- g. Remove fluid filter element (4) from filter cup.
- h. Disconnect fuel hose (14) from connector receptacle (13).

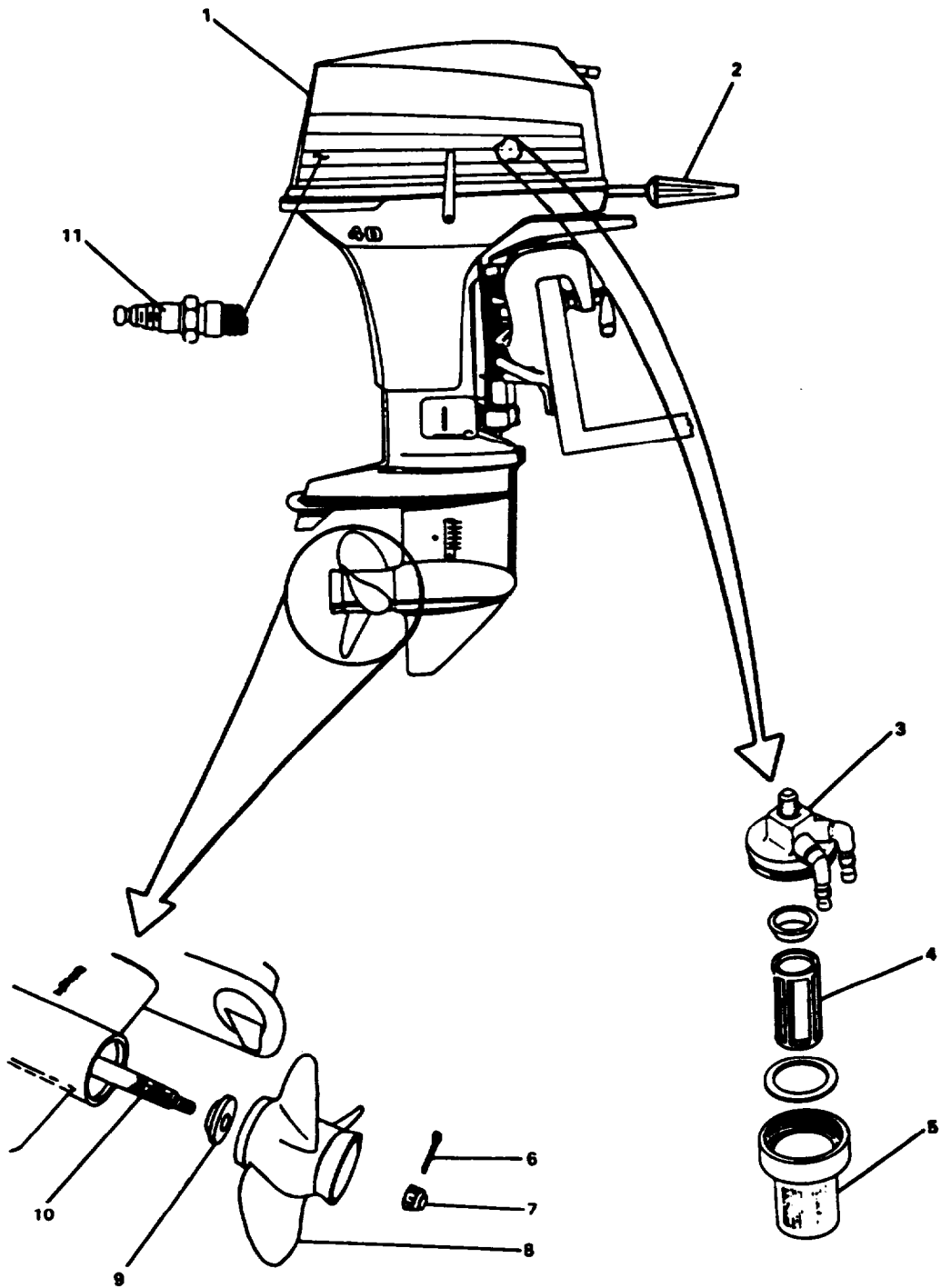


FIGURE 2-186. Outboard Motor (Sheet 1 of 2).

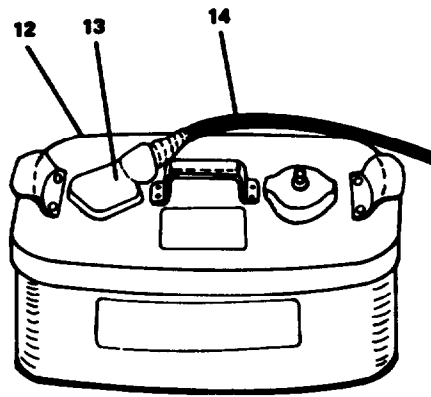


FIGURE 2-186. Outboard Motor (Sheet 2 of 2).

- i. Remove engine fuel tank (12).

## **REPAIR**

Repair at this level of maintenance is by replacement of spark plug (11), fluid filter element (4), propeller assembly (8), and engine fuel tank (12).

## **ASSEMBLY**

- a. Install engine fuel tank (12).
- b. Connect fuel hose (14) to connector receptacle (13).
- c. Install fluid filter element (4) into filter cup (5).
- d. Screw filter cup into filter base (3).
- e. Grease propeller shaft splines (10) with water resistant grease.
- f. Align propeller assembly (8) splines with propeller shaft splines (10) and install propeller assembly against thrust washer (9).
- g. Install nut (7) and torque to 55 ft-lb (75 N•m). Install cotter pin (6).
- h. Set spark plug (11) gap to 0.017 - 0.18 in. (0.5 - 0.6 mm).
- i. Install new spark plug finger-tight and torque to 14 ft-lb.
- j. Install spark plug wire.
- k. Install cowling (1).

## **REPLACEMENT**

- a. Lift engine onto transom of workboat.
- b. Tighten mounting clamps until engine is secure.
- c. Connect fuel line (14) to motor.

## **INSPECTION**

- a. Make sure engine fuel tank is full.
- b. Make sure fuel line is firmly seated in connector receptacle and check for fuel leaks.
- c. Check propeller assembly for chipped or bent blades. Make sure cotter pin is in place.
- d. Visually inspect the entire engine.

---

**2-217. Replace Inflatable Liferaft. (FIGURE 2-187)**

---

This task covers: a. Removal, b. Replacement.

---

**INITIAL SETUP****Tools**Tool Kit, General Mechanic's,  
5180-00-699-5273**General Safety Instruction**

Disconnecting painter line from shackle does not prevent inflation. Be sure not to pull on or snag the painter line.

**Materials/Parts**Liferaft, Inflatable, 25-Person  
NSN 4220-01-444-6260  
Release, Lifesaving Equipment P/N DK84.1-M  
NSN 4220-01-493-9233

Liferaft weighs approximately 500 pounds and should be handled with extreme care. Use suitable lifting device when moving the equipment. Failure to comply could cause injury to personnel or damage to equipment.

---

**REMOVAL****WARNING**

Disconnect the painter line from the cradle (11) anchor before attempting to move liferaft. Pulling or snagging painter line (6) can cause inflation. Accidental inflation could cause injury or death to personnel or damage to equipment.

**NOTE**

The following procedure pertains to vessels with the hydrostatic release (2) installed. For vessels with the release, lifesaving equipment (8) (CAGE 02NT5, P/N DK84.1-M) installed the procedures remain the same.

- a. Disconnect painter line (6) from the cradle (11).
- b. Loosen the retaining harness (4) at end opposite of hydrostatic release (2).

**CAUTION**

If liferaft displays signs of movement in cradle or possible accidental launching when the retaining harness (4) is loosened, secure the liferaft to the cradle (11) with a suitable sized nylon line prior to releasing the pelican hook.

- c. Slide locking ring (3) over pelican hook (5) to release pelican hook.
- d. Remove pelican hook (5) from the hydrostatic release (2).
- e. Remove the retaining harness (4) from liferaft container (1).

**WARNING**

**Liferaft weighs approximately 500 pounds and should be handled with extreme care. Use suitable lifting device when moving the equipment. Failure to comply could cause injury to personnel or damage to equipment.**

- f. Lift liferaft (1) from cradle (11).
- g. Remove the hydrostatic release (2) from the shackle (7) and remove from the cradle (11).
- h. Remove the retaining harness (4) from the cradle (11)

**REPLACEMENT**

- a. Connect the retaining harness (4) to the cradle (11).
- b. Position the hydrostatic release (2) on the inboard side of the cradle (11) and attach to the cradle (11) with shackle (7).

**WARNING**

**Liferaft weighs approximately 500 pounds and should be handled with extreme care. Use suitable lifting device when moving the equipment. Failure to comply could cause injury to personnel or damage to equipment.**

- c. Position the liferaft (1) on the cradle (11).
- d. Connect the hydrostatic release (2) to the retaining harness (4) by installing pelican hook (5) and locking ring (3).
  - (1) If the release, lifesaving equipment (8) (CAGE 02NT5, P/N DK84.1-M) is used, ensure release pawl (10) is in the locked position, the safety pin (12) is installed and that the push to release plunger (9) is facing inboard.
- e. Tighten the retaining harness (4) until the liferaft is securely seated in the cradle (11), but not so much as to damage the liferaft container (1).
- f. Connect painter line (1) to the cradle (11). Ensure that the painter line is positioned within the cradle. This will help prevent accidental inflation.



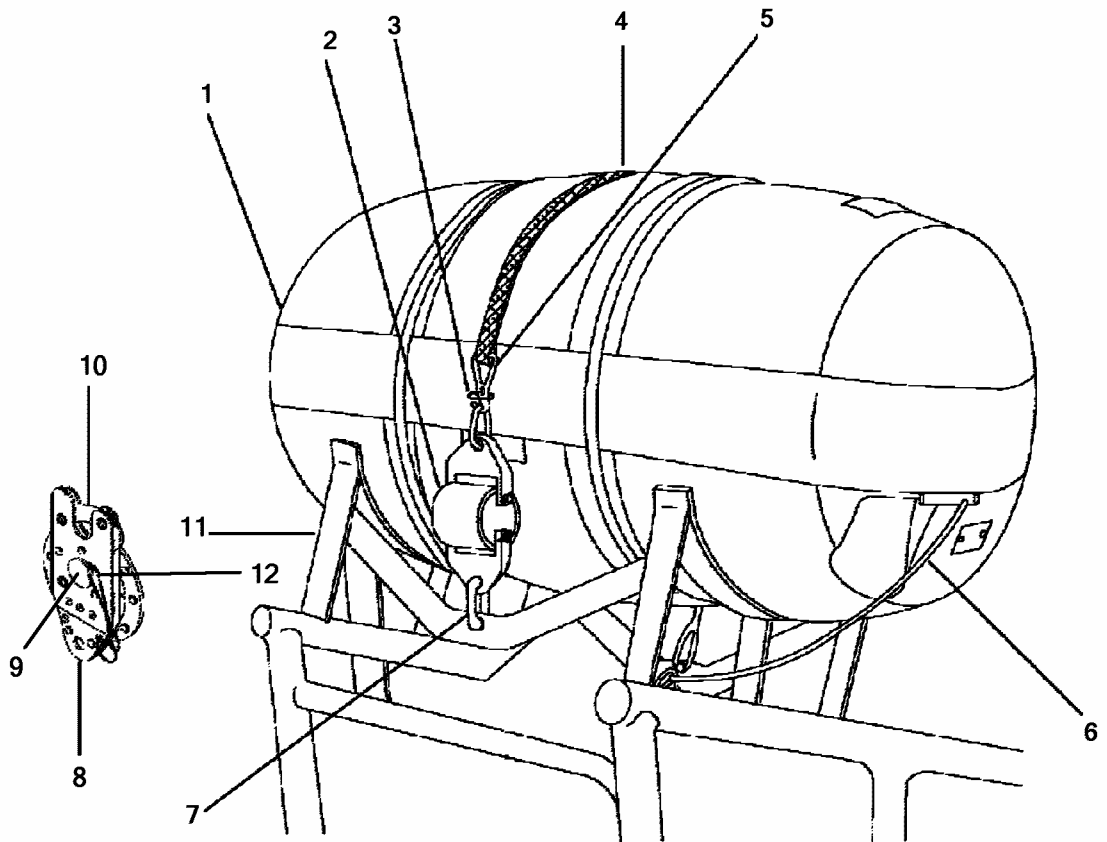


Figure 2-187. Liferaft Removal.

**2-218. Repair Crane Assembly. (FIGURE 2-188).**

---

This task covers: a. Disassembly, b. Repair, c. Assembly.

---

**INITIAL SETUP**

Tools

Tool Kit, General Mechanic's,  
5180-00-699-5273  
Tool Kit, Electrician's,  
5180-00-391-1087

Equipment Condition

Electrical power OFF at deck  
switch and tagged "Out of  
Service - Do Not Operate."

Materials/Parts

Controller Motor P/N YMD-4890  
Controller Motor (Remote) P/N YMD-4891  
Electrical Power Cable P/N YMD-4895  
Gasket P/N AMD-655-19  
Single Leg Wire Rope Assembly P/N YMD-4893  
Clear Silicone Sealer, Item 25, Appendix C  
Warning Tag, Item 1, Appendix C

---

**DISASSEMBLY**

- a. Extend single leg wire rope assembly (3).
- b. Turn off electrical power at deck switch (7) and disconnect wire rope assembly from winch assembly (2).
- c. Remove electrical fittings (1,6).
- d. Tag and disconnect electrical leads.
- e. Remove electrical power cable (12).
- f. Remove hexagon capscrews (10) and lockwashers (11).
- g. Remove conduit box (8) and gasket (9).
- h. Remove motor controller (4).
- i. Remove motor controller (remote) (5).

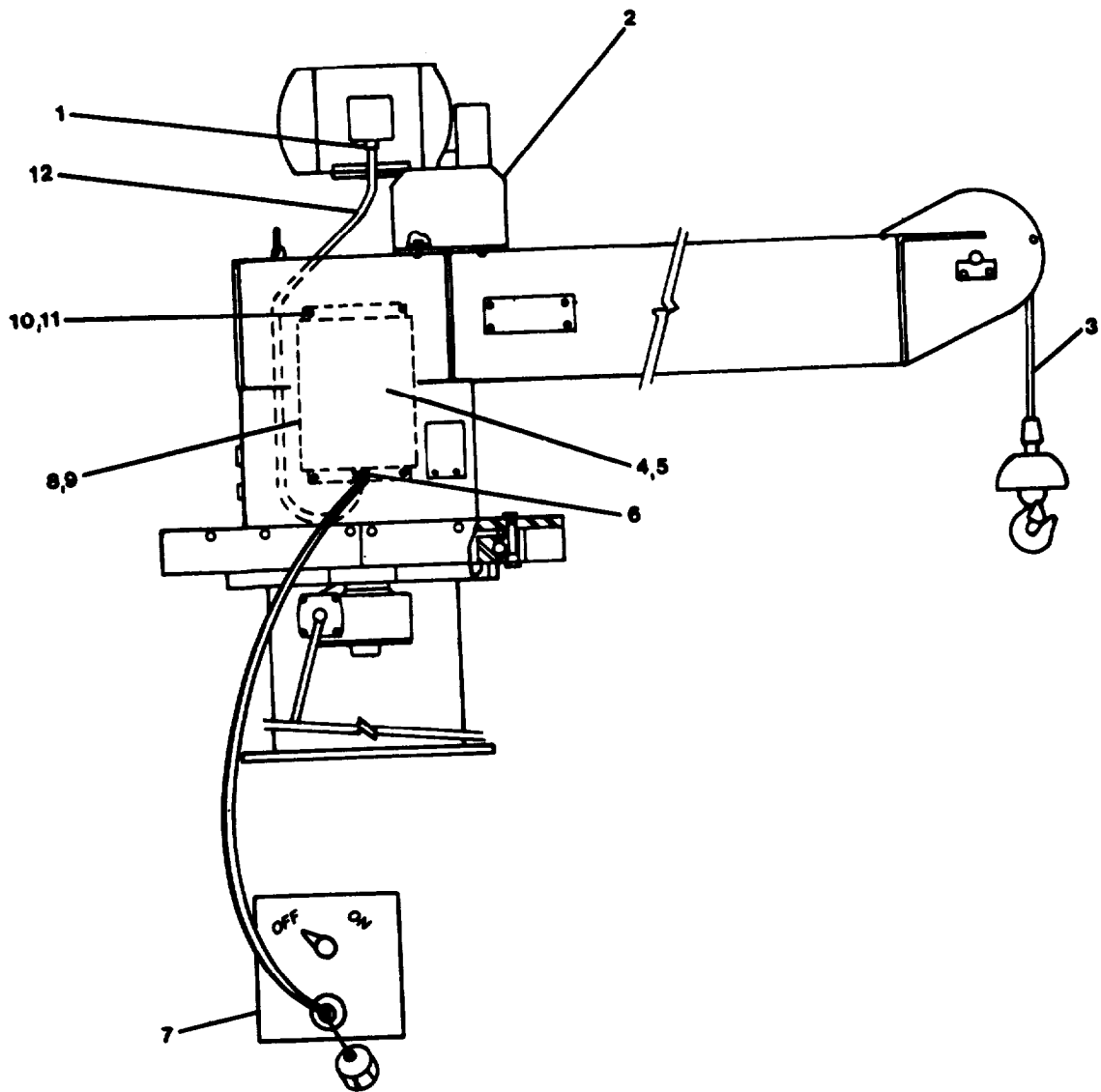


FIGURE 2-188. Repair Crane Assembly.

**REPAIR**

Repair at this level of maintenance is by replacement of controller motor (4), controller motor (remote) (5), gasket (8), electrical power cable (12), single leg wire rope assembly (3).

**ASSEMBLY**

- a. Install motor controller (remote) (5).
- b. Install motor controller (4).
- c. Install conduit box (8) and gasket (9).
- d. Install hexagon capscrews (10) and lockwashers (11).
- e. Install electrical power cable (12).
- f. Install electrical fitting (1,6) and apply sealer.
- g. Attach single leg wire rope assembly (3) to winch assembly (2).
- h. Turn ON electrical power at deck switch (7) and retract wire rope assembly to winch assembly.

---

**2-219. Repair Winch Assembly. (FIGURE 2-189)**

---

This task covers: a. Disassembly, b. Repair, c. Assembly.

---

**INITIAL SETUP****Tools**

Tool kit, general mechanic's,  
5180-00-699-5273

**Equipment Condition**

Electrical power to winch OFF and  
tagged 'Out of Service - Do Not  
Operate.'

---

**DISASSEMBLY**

- a. Remove hexagon capscrew (1) and lockwasher (2).
- b. Remove coupling guard (7).
- c. Remove hexagon capscrew (4) and lockwasher (5).
- d. Remove taper pin (6).
- e. Remove grease fitting (3).

**REPAIR**

Repair at this level of maintenance is by replacement of worn or defective parts,

**ASSEMBLY**

- a. Install grease fitting (3).
- b. Install taper pin (6).
- c. Install lockwasher (5) and hexagon capscrew (4).
- d. Install coupling guard (7).
- e. Install lockwasher (2) and hexagon capscrew (1).

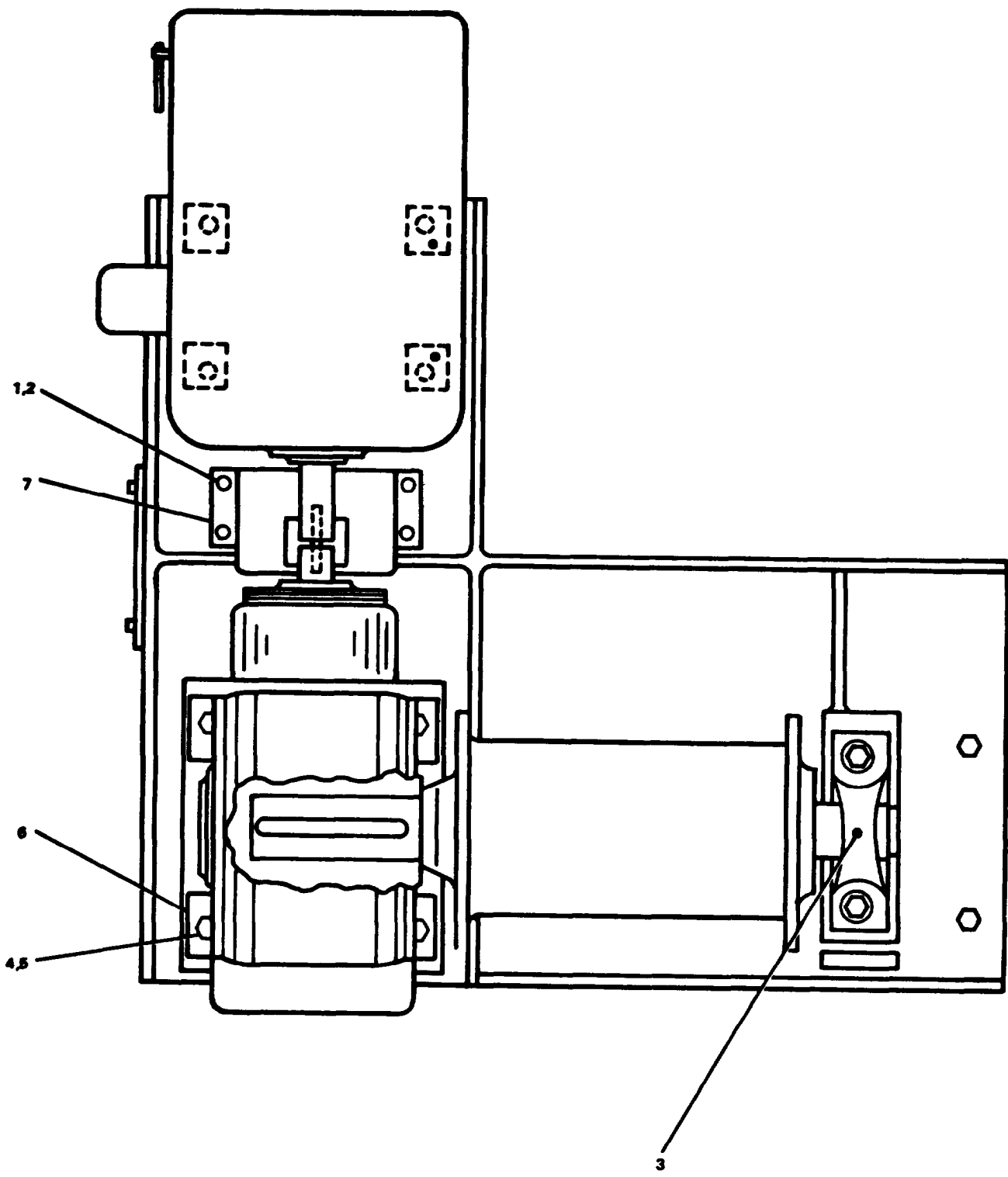


FIGURE 2-189. Repair Winch.

---

**2-220. Replace/Repair Portable Davit. (FIGURE 2-190)**

---

This task covers: a. Removal, b. Disassembly, c. Repair, d. Assembly,  
e. Replacement.

---

**INITIAL SETUP**

**Tools**

Tool kit, general mechanic's,  
5180-00-699-5273

**Materials/Parts**

Rope 1/2" nylon, 3 strand,  
high strength, shock resistant  
P/N 43-1041-8093  
Portable davit P/N 803-1645271

---

**REMOVAL**

- a. Lift portable davit (1) from davit socket (5).

**ASSEMBLY**

- a. Remove bottom block (4).
- b. Remove rope (3) from top block (2).

**REPAIR**

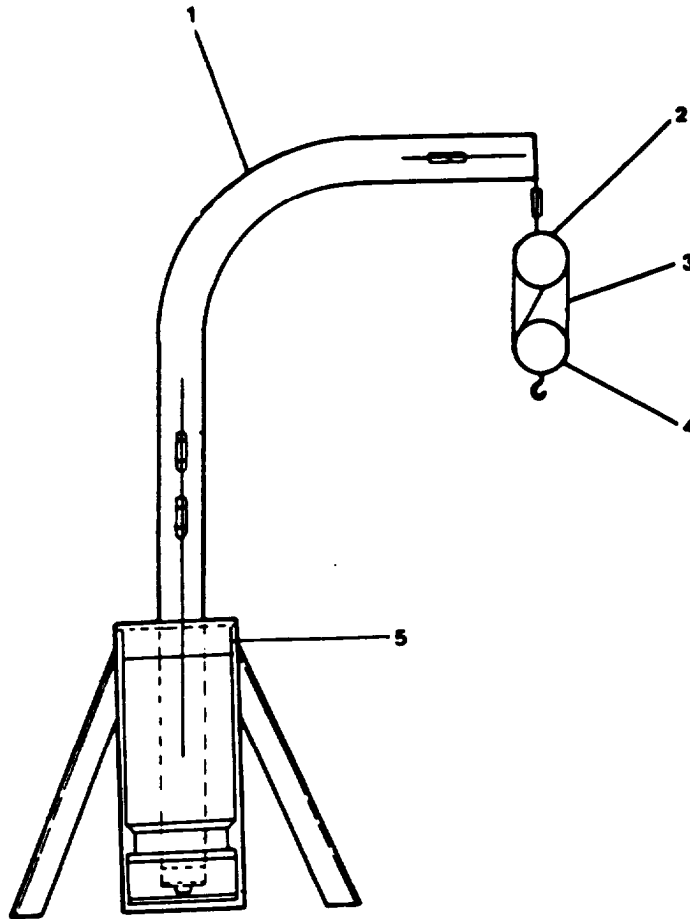
Repair at this level of maintenance is by replacement of rope (3).

**ASSEMBLY**

- a. Attach rope (3) to top block (2).
- b. Install bottom block (4).

**REPLACEMENT**

- a. Install portable davit (1) into davit socket (5).



**FIGURE 2-190. Repair Portable Davit Assembly.**



<b>MAINTENANCE OF CONTROL CENTERS/SWITCHBOARDS</b>
--

---

**2-221. Replace/Repair Motor Control Center, Auxiliary Machinery Vent Room No. 1. (FIGURE 2-191)**

---

This task covers: a. Removal, b. Repair, c. Replacement.

---

**INITIAL SETUP**

**Tools**

Tool kit, electrician's  
5180-00-391-1087

**Equipment Condition**

On ship service switchboard turn OFF  
AUK MCHRY MCC circuit breaker and tag  
"Out of Service - Do Not Operate."

**Materials/Parts**

Refer to motor controller/controller  
being serviced.  
Warning tags, Item 1, Appendix C

---

**REMOVAL**

- a. Motor controller, Emergency Lube Oil Prelube Pump. Refer to paragraph 2-222.
- b. Controller, No. 1 & 2 SSDG JACKET WATER HEATER. Refer to paragraph 2-224.
- c. Motor controller, Air Compressor No. 1 & 2. Refer to paragraph 2-226.
- d. Motor controller, Dirty Lube Oil Pump. Refer to paragraph 2-228.
- e. Controller, Main Engine 1 & 2 JACKET WATER HEATER, Refer to paragraph 2-230.
- f. Motor Control Center, Auxiliary Machinery Vent Room No. 1. Refer to paragraph 2-232.

**REPAIR**

Refer to replacement parts list of motor controller/controller being serviced.

**REPLACEMENT**

- a. Motor Control Center, Auxiliary Machinery Vent Room No. 1. Refer to paragraph 2-232.
- b. Controller, Main Engine 1 & 2 JACKET WATER HEATER. Refer to paragraph 2-230.

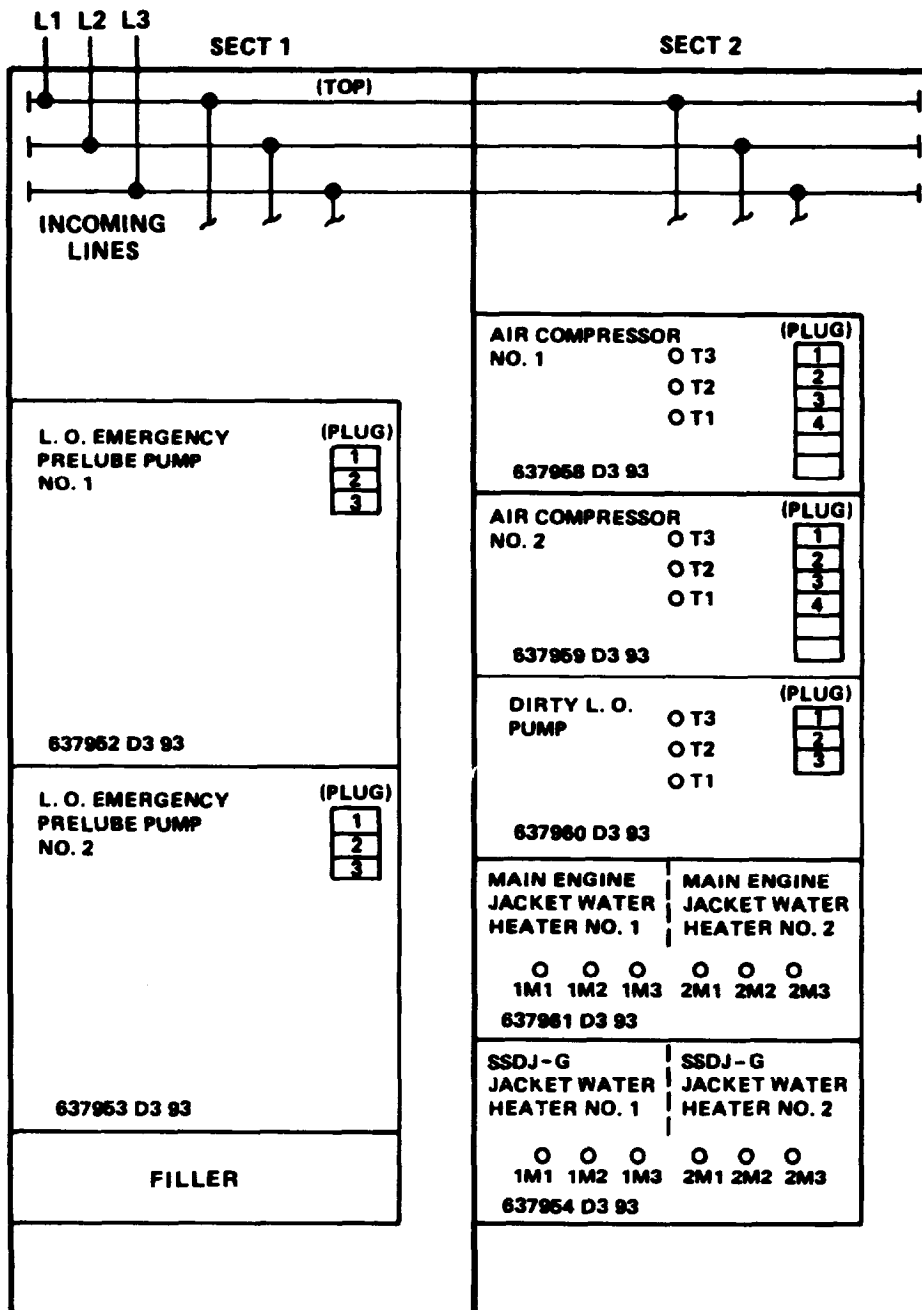


FIGURE 2-191. Motor Control Center Auxiliary Machinery Room Vent No. 1.

- c. Motor controller, Dirty Oil Pump. Refer to paragraph 2-228.
- d. Motor controller, Air Compressor No. 1 & 2. Refer to paragraph 2-226.
- e. Controller, No. 1 & 2 SSDG JACKET WATER HEATER. Refer to paragraph 2-224.
- f. Motor controller, Emergency Lube Oil Prelube Pump. Refer to paragraph 2-222.
- g. On ship service switchboard turn ON AUX MCHRY MCC circuit breaker and remove tag.

**2-222. Replace Motor Controller, Emergency Lube Oil Prelube Pump. (FIGURE 2-192).**

---

This task covers:    a. Removal,                    b. Replacement,                    c. Test.

---

**INITIAL SETUP**

Tools

Tool Kit, Electrician's,  
5180-00-391-1087

Equipment Condition

On Ship Service Switchboard Turn  
OFF AUX MCHRY MCC Circuit Breaker  
and Tag "Cut off Service" - Do Not Operate."

Materials/Parts

Warning Tags, Item 1, Appendix C

---

**REMOVAL**

- a. Loosen two latch screws (1) on motor controller door (2).

**NOTE**

**Circuit breaker must be "OFF" to open door.**

- b. Open door.
- c. Tag and disconnect electrical leads to indicator lights and push switches on rear of door at contacts (11) on motor starter.
- d. Remove cable ties (12) securing cable harness to motor controller.
- e. Remove four screws (5) securing door hinges (3) with support bracket (4).
- f. Remove support brackets, door and cable assembly.
- g. Tag and disconnect electrical leads (9) from terminal blocks (8). (External wiring).
- h. Tag and disconnect electrical leads from contacts (10) on thermal release relay. (External wiring).
- i. Release dog latches (7) on motor controller.

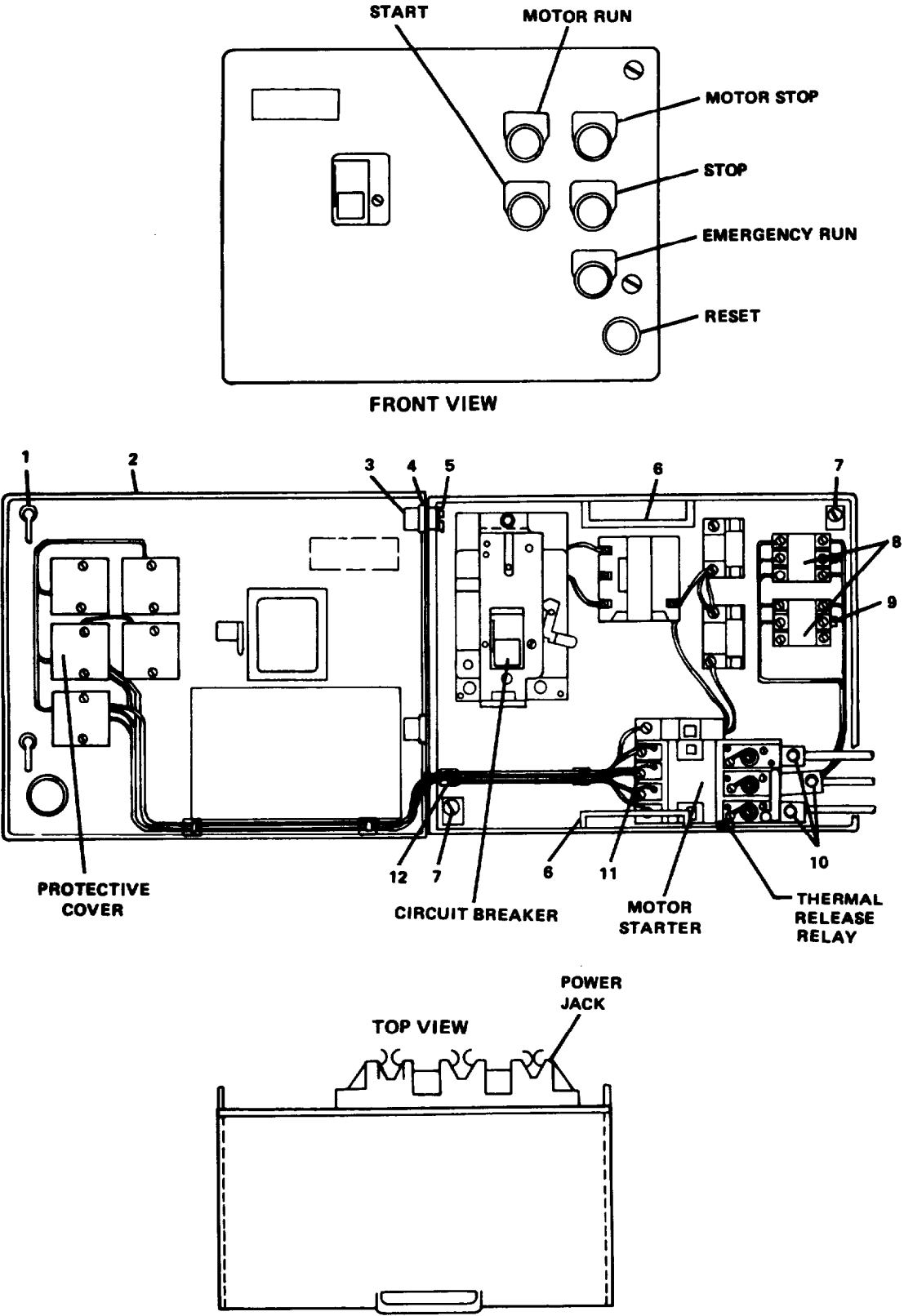


FIGURE 2-192. Motor Controller (Emergency Lube Oil Prelube Pump).

- j. Firmly grasp handles (6) and pull motor controller forward as it disconnects from power jack.
- k. Remove motor controller.

**REPLACEMENT**

- a. Firmly grasp handles (6) and install motor controller into enclosure.
- b. Push on handles (6) until motor controller engages with power jack.
- c. Secure dog latches (7) to motor controller.
- d. Connect electrical leads to contacts (10) on thermal release relay. (External wiring). Remove tags.
- e. Connect electrical leads (9) to terminal blocks (8). (External wiring). Remove tags.
- f. Position door (2), door hinges (3) and support bracket (4) on enclosure.
- g. Install four screws (5) and secure support brackets (4) with door hinges (3) on motor controller.
- h. Position cable harness in motor controller and secure cable with cable ties (12).
- i. Connect electrical leads from indicator lights and push switches on rear of door at contacts (11) on motor starter. Remove tags.
- j. Close door (2).
- k. Secure door to motor controller with two latch screws (1).
- l. On main switchboard turn ON AUX MCHRY MCC circuit breaker and remove tag,

**TEST**

- a. Turn ON motor controller circuit breaker.
- b. Check motor controller operation. Refer to TX 55-1905-223-10.

---

**2-223. Repair Motor Controller, Emergency Lube Oil Prelube Pump. (FIGURE 2-193, Sheets 1 - 3)**

---

This task covers:      a. Disassembly,      b. Repair,      c. Assembly.

---

**INITIAL SETUP****Tools**

Tool Kit, General Mechanic's,  
5180-00-699-5273

Tool Kit, Electrician's,  
5180-00-391-1087

**Equipment Condition**

Motor Controller Removed as Specified in  
Paragraph 2-222.

**Materials/Parts**

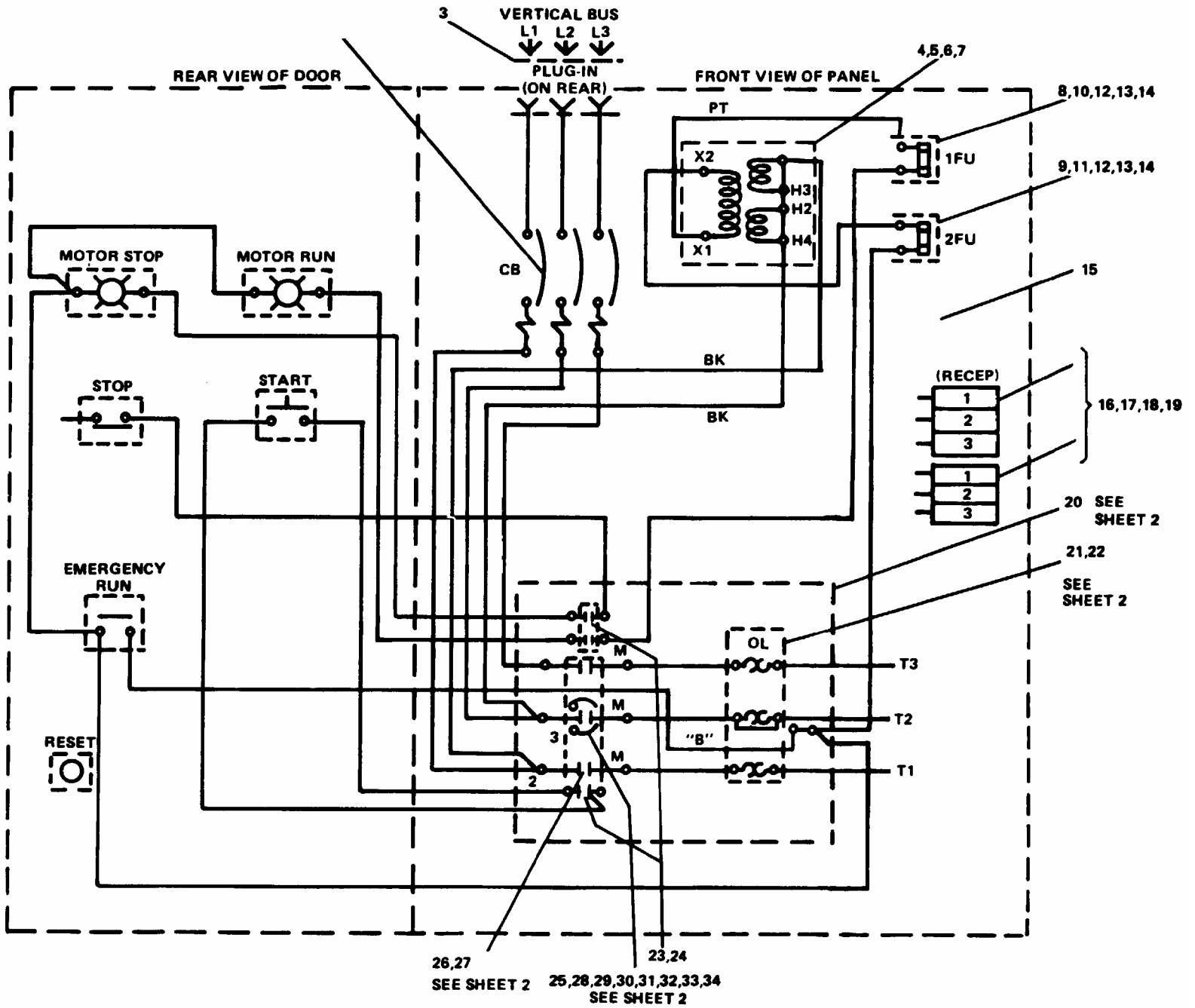
Motor Starter P/N A10E-2  
Electrical Contact Kit P/N 6-35-2  
Armature Lever Relay P/N 48-1020  
Electrical Coil P/N 9-1889-1  
Electrical Contact Assembly P/N C320KB1  
Auxiliary Contact P/N C320KB2  
Transformer P/N 42-3537-19  
Fuse Cartridge P/N 44-2074-12  
Circuit Breaker P/N HMCP-100R3C  
Incandescent Lamps P/N 28-2202  
Electrical Contacts P/N 10250T51,  
P/N 10250T53  
Thermal Heaters, P/N H1049  
Warning Tags, Item 1, Appendix C

---

**DISASSEMBLY**

- a. Position motor controller (15, FIGURE 2-193, Sheet 1) on a clean flat surface.
- b. Motor starter.
  - (1) Remove three mounting screws from motor starter (20, FIGURE 2-193, Sheet 2).
  - (2) Lift motor starter out of motor controller (15).
- c. Electrical contact kit.
  - (1) Position motor starter on a clean flat surface.
  - (2) Loosen two cover screws (34, FIGURE 2-193, Sheet 2) on electrical contact kit (25). Remove cover.
  - (3) Lift armature lever relay (32) out of each slot on armature lever relay push bars. Note position of armature lever relay for assembly.

Figure 2-193. Motor Controller (Emergency Lube Oil Prelube Pump)  
(Sheet 1 of 3).





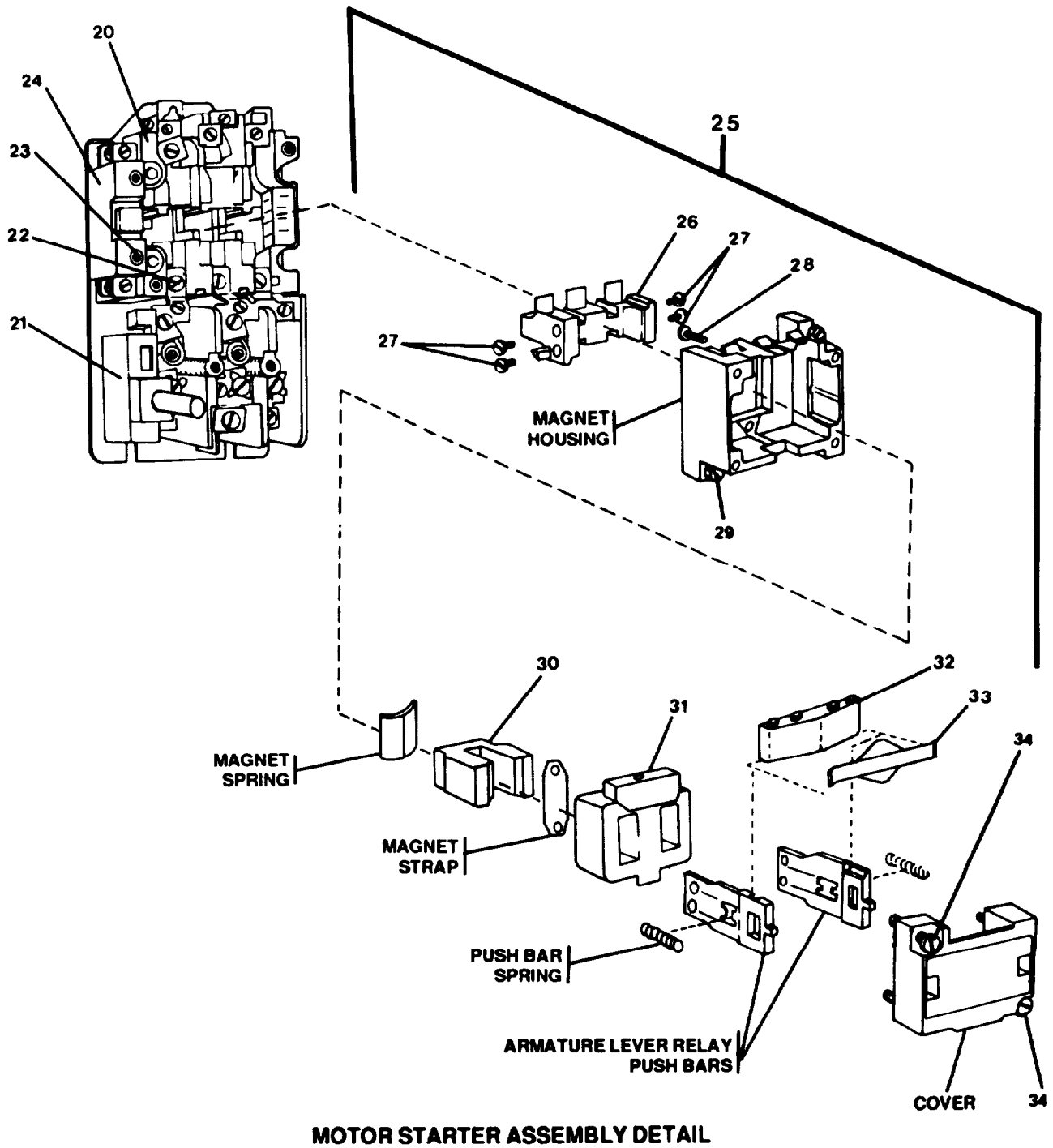


FIGURE 2-193. Motor Controller (Emergency Lube Oil Prelube Pump)  
(Sheet 2 of 3).

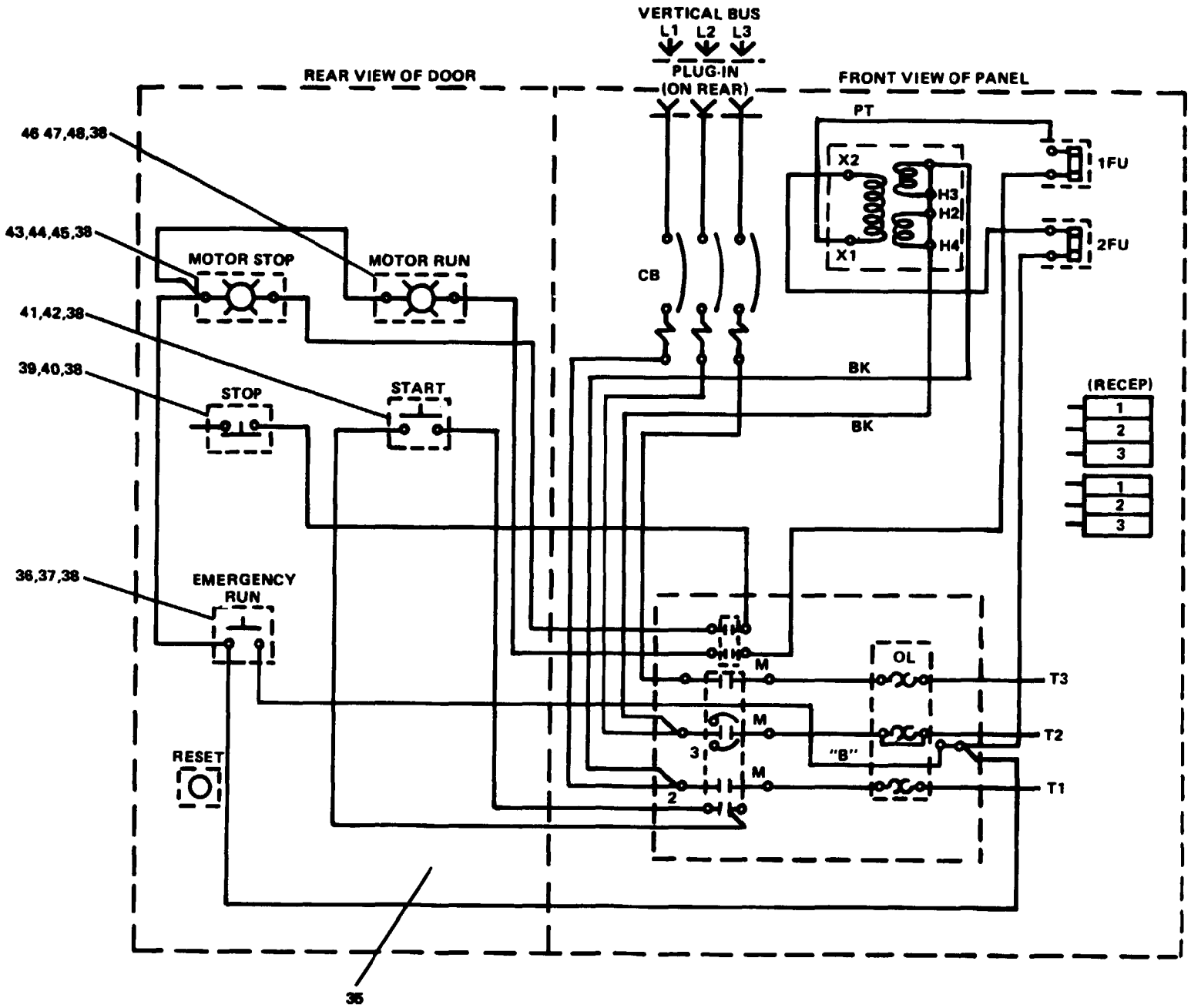


FIGURE 2-193. Motor Controller (Emergency Lube Oil Prelube Pump)  
(Sheet 3 of 3).

- (4) Detach and remove armature spring plate (33) from slotted ends of each armature lever relay push bar.
- (5) Remove electrical coil (31) by unplugging from socket on magnet housing of electrical contact kit (25).
- (6) Remove two hex head screws (29) securing magnet housing to motor starter (20).
- (7) Separate magnet housing from motor starter, by pulling straight out.
- (8) Remove two machine screws (28) securing magnet spring and magnet frame (30) to magnet strap.
- (9) Remove magnet strap, magnet frame (30) and magnet spring from magnet housing.

d. Electrical contact assembly.

- (1) Remove four machine screws (27) securing electrical contact assembly (26) to each side of armature lever relay push bars.
- (2) Separate electrical contact assembly at rear of magnet housing.
- (3) Withdraw armature lever relay push bars from front of magnet housing.  
Note position of push bars for assembly.
- (4) Compress and remove push bar springs from spring slots on each armature lever relay push bar.

e. Thermal release relay.

- (1) Remove three machine screws (22) from thermal release relay (21).
- (2) Position thermal release relay with control circuit wire exposed.
- (3) Tag and disconnect control circuit wire.
- (4) Remove thermal release relay.

f. Auxiliary contact.

- (1) Loosen two screws (23) on auxiliary contact (24).
- (2) Disconnect auxiliary contact from motor starter (20).
- (3) Repeat steps (1) and (2) for removal of auxiliary contact on opposite side of motor starter, if applicable.

g. Transformer.

- (1) Tag and disconnect electrical leads from transformer (4, FIGURE 2-193, Sheet 1).
- (2) Remove four hex plain nuts (5), lockwashers (6) and machine screws (7) from transformer.

(3) Lift transformer out of motor controller (15).

h. Fuseholder block.

(1) Tag and disconnect electrical leads from fuse blocks (8) and (9).  
(Internal wiring).

(2) Remove fuse cartridges (10 and 11).

(3) Remove two plain hex nuts (12), lockwashers (13) and machine screws (14)  
from each fuse block.

(4) Remove fuse blocks.

i. Terminal block (receptacle).

(1) Tag and disconnect electrical leads from terminal blocks (16). (Internal  
wiring).

(2) Remove two plain hex nuts (17), lockwashers (18) and machine screws (19)  
from each terminal block.

(3) Remove terminal blocks (16).

j. Circuit breaker.

(1) Tag and disconnect electrical leads from circuit breaker (1). (Internal  
wiring).

(2) Remove self-locking screw (2) and detach switch cover.

(3) Loosen circuit breaker mounting screws.

(4) Separate circuit breaker (1) from connector assembly (3).

(5) Lift circuit breaker out of motor controller.

k. Push switches/indicator lights. FIGURE 2-193 (Sheet 3 of 3)

(1) Position motor controller door (35) on a clean flat surface.

(2) Remove two screws from protective cover over each push switch and  
indicator light at rear of door.

(3) Remove protective covers.

(4) Push switches.

(a) Push switch (36).

1 Tag and disconnect electrical leads from push switch (36) at rear of  
door.

2 Unscrew locknut (38) from push switch at front of door.

3 Remove push switch and electrical contact (37) from rear of door.

(b) Push switch (39).

Refer to steps (a) 1 through 3 to remove push switch (39) and electrical contact (40).

(c) Push switch (41).

Refer to steps (a) 1 through 3 to remove push switch (41) and electrical contact (42).

(5) Indicator lights.

(a) Indicator light (43).

1 Unscrew light lens (44) from indicator light at front of door.

2 Remove incandescent lamp (45).

3 Tag and disconnect electrical leads from indicator light (43) at rear of door.

4 Unscrew locknut (38) from indicator light (43) at front of door.

5 Remove indicator light (43) from door.

(b) Indicator light (46).

1 Unscrew light lens (47) from indicator light at front of door.

2 Remove incandescent lamp (48).

3 Tag and disconnect electrical leads from indicator light (46) at rear of door.

4 Unscrew locknut (38) from indicator light (46) at front of door.

5 Remove indicator light (47) from door.

## **REPAIR**

Repair at motor controller consists of replacing: motor starter (20), electrical contact kit (25), armature lever relay (32), electrical coil (31), electrical contact assembly (26), auxiliary contact (24), transformer (4), fuse cartridge (10,11), circuit breaker (1), incandescent lamp (45, 48), electrical contact (37, 40, 42), thermal relay heater (21).

## **ASSEMBLY**

a. Position motor controller door (35) on a clean flat surface.

b. Indicator lights/push switches. FIGURE 2-193 (Sheet 3).

(1) Indicator lights.

(a) Indicator light (46).

- 1 Position indicator light (46) in door.
- 2 Install locknut (38) on indicator light (46) at front of door.
- 3 Connect electrical leads to indicator light (46) at rear of door. Remove tags.
- 4 Install incandescent lamp (48).
- 5 Install light lens (47) on indicator light at front of door.

(b) Indicator light (43).

- 1 Position indicator light (43) in door.
- 2 Install locknut (38) on indicator light (43) at front of door.
- 3 Connect electrical leads to indicator light (43) at rear of door. Remove tags,
- 4 Install incandescent lamp (45).
- 5 Install light lens (44) on indicator light at front of door.

(2) Push switches,

(a) Push switch (41).

- 1 Position push switch and electrical contact (42) at rear of door.
- 2 Install locknut (38) on push switch.
- 3 Connect electrical leads to push switch at rear of door.

(b) Push switch (39).

Refer to steps (a) 1 through 3 to install push switch (39) and electrical contact (40).

(c) Push switch (36).

Refer to steps (a) 1 through 3 to install push switch (36) and electrical contact (37).

c. Position motor controller (15) on a clean flat surface.

d. Circuit breaker. FIGURE 2-193 (Sheet 1).

(1) Position circuit breaker (1) over connector assembly (3) in motor controller.

- (2) Engage circuit breaker on connector assembly.
  - (3) Secure circuit breaker to motor controller panel with mounting screws.
  - (4) Install switch cover over circuit breaker and secure cover with self locking screw (2).
  - (5) Connect electrical leads to circuit breaker (1). Remove tags.
- e.** Terminal block (receptacle).
- (1) Position terminal blocks (16) over mounting screw holes on motor controller panel.
  - (2) Install two machine screws (19), lockwashers (18) and plain hex nuts (17) and secure each terminal block to motor controller panel.
  - (3) Connect electrical leads to terminal blocks (16). Remove tags.
- f.** Fuseholder block.
- (1) Position fuseholder blocks (8 and 9) over mounting screw holes on motor controller panel.
  - (2) Install two machine screws (14), lockwashers (13) and plain hex nuts (12) and secure each terminal block to motor controller panel.
  - (3) Connect electrical leads to fuseholder blocks. Remove tags.
  - (4) Install fuse cartridges (10 and 11).
- g.** Transformer.
- (1) Position transformer (4) over mounting screw holes on motor controller panel.
  - (2) Install four machine screws (7), lockwashers (6) and plain hex nuts (5) and secure each terminal block to motor controller panel.
  - (3) Connect electrical leads to transformer. Remove tags.
- h.** Auxiliary contact.
- (1) Position motor starter (20) on a clean flat surface.
  - (2) Attach auxiliary contact (24) to motor starter (20).
  - (3) Secure auxiliary contact with two attaching screws (23) to motor starter.
  - (4) Connect electrical leads to auxiliary contact.
  - (5) Repeat steps (2) through (4) to install auxiliary contact on opposite side of motor starter.

i. Thermal release relay.

- (1) Position thermal release relay (21) on motor starter with control circuit wire exposed.
- (2) Connect control circuit wire to thermal release relay. Remove tag.
- (3) Secure thermal release relay to motor starter base plate with three machine screws (22).

j. Electrical contact assembly.

- (1) Compress and install push bar springs into spring slots on each armature lever relay push bar.
- (2) Install armature lever relay push bars into magnet housing as noted during disassembly.
- (3) Position electrical contact assembly (26) on armature lever relay push bars at rear of magnet housing.
- (4) Install four machine screws (27) and secure electrical contact assembly (26) to armature lever relay push bars.

k. Electrical contact kit.

- (1) Position magnet spring, magnet frame (30) and magnet strap into magnet housing.
- (2) Install two machine screws (28) and secure magnet spring and magnet frame (30) to magnet housing with magnet strap.
- (3) Install by plugging electrical coil (31) into socket on magnet housing of electrical contact kit (25).
- (4) Install by attaching armature spring plate (33) to slotted ends of each armature lever relay push bars.
- (5) Lower armature lever relay (32) into each slot on armature lever relay push bars as noted during disassembly. It may be necessary to depress armature spring plate (33) slightly to accommodate armature lever relay (32).
- (6) Position cover on electrical contact kit (25).
- (7) Install two machine screws (34) and secure cover.

l. Motor starter.

- (1) Position motor starter over mounting screw holes on motor controller panel.
- (2) Install three mounting screws and secure motor starter to panel.

m. Replace motor controller as specified in paragraph 2-222.



---

**2-224. Replace Controller 1, SSDG Jacket Water Heater No. 1 and No. 2.  
(FIGURE 2-194)**

---

This task covers: a. Removal, b. Replacement, c. Test.

---

**INITIAL SETUP****Tools**

Tool kit, electrician's,  
5180-00-391-1087

**Equipment Condition**

On ship service switchboard turn OFF  
AUX MCHRY MCC circuit breaker and tag  
"Out of Service - Do Not Operate."

**Materials/Parts**

Warning tags, Item 1, Appendix C

---

**REMOVAL**

- a. Loosen two latch screws (1) on controller door (2).

**NOTE**

Circuit breaker must be "OFF" to open door.

- b. Open door.
- c. Remove four screws (5) securing door hinges (3) with support brackets (4).
- d. Remove support brackets and door.
- e. Tag and disconnect electrical leads (9) from circuit breakers (7).
- f. Loosen dog latches (8) on controller (10).
- g. Firmly grasp handles (6) and pull controller forward as it disconnects from power jack.
- h. Remove controller from enclosure.

**REPLACEMENT**

- a. Firmly grasp handles (6) and install controller into enclosure.
- b. Push on handles (6) until controller engages with power jack.

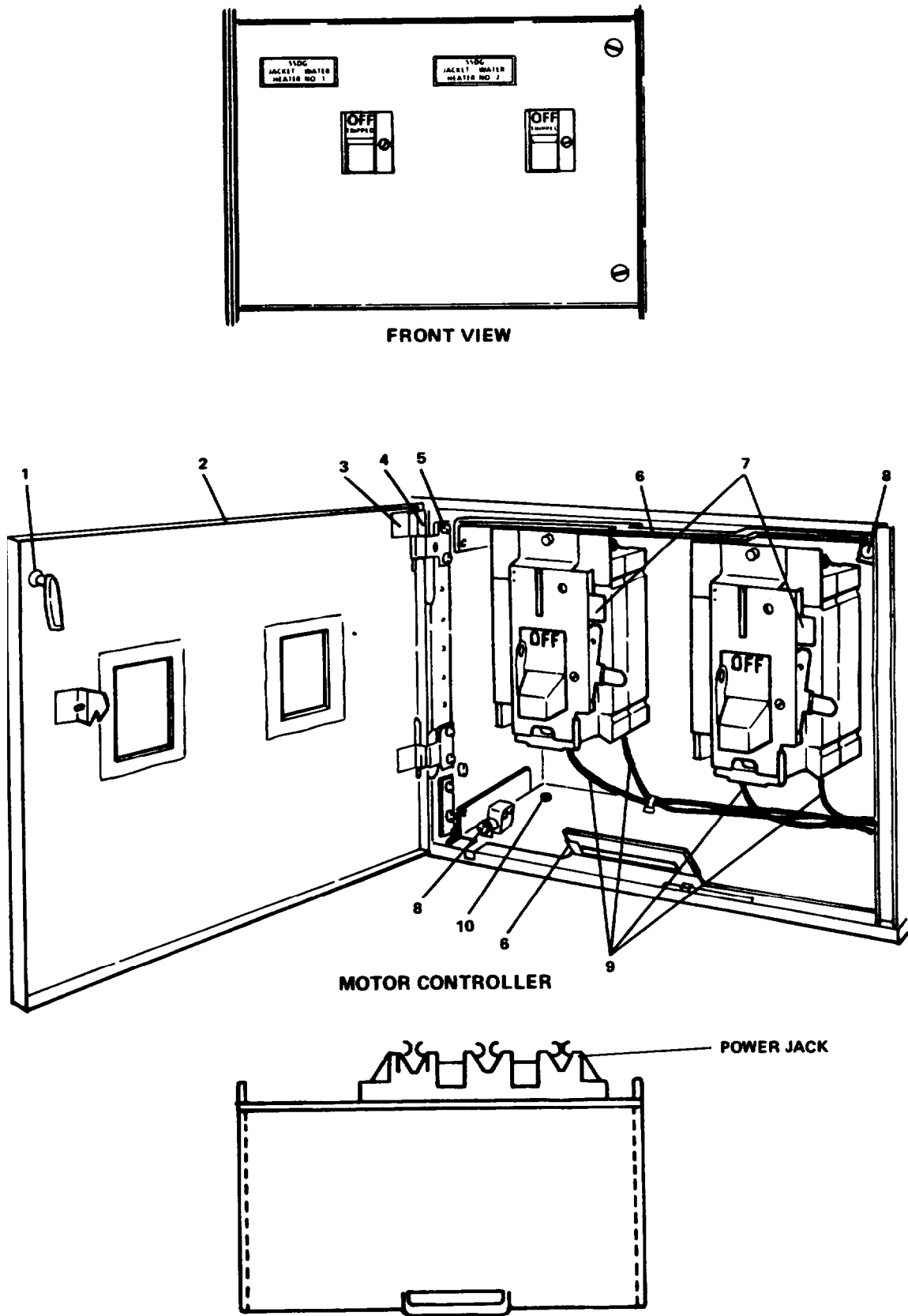


FIGURE 2-194. Controller (No. 1 & 2 SSDG Jacket Water Heater).

- c. Secure dog latches (8) to controller.
- d. Connect electrical leads (9) to circuit breakers (7). Remove tags.
- e. Position door (2), door hinges (3) and support brackets (4) on enclosure.
- f. Install four screws (5) and secure support brackets (4) with door hinges (3) on controller.
- g. Close door.
- h. Secure door on front panel with two latch screws (1).
- i. On main switchboard turn ON AUX MCHRY MCC circuit breaker and remove tags.

**TEST**

- a. Turn ON motor controller circuit breaker.
- b. Check motor controller operation. Refer to TM 55-1905-223-10.

**2-225. Repair Controller, 2 SSDG Jacket Water Heater No. 1 and No. 2.  
(FIGURE 2-195)**

---

This task covers: a. Disassembly, b. Repair, c. Assembly.

---

**INITIAL SETUP**

**Tools**

Tool kit, electrician's,  
5180-00-391-1087

**Equipment Condition**

Controller removed as specified  
in paragraph 2-224.

**Materials/Parts**

Circuit breaker P/N FB3015V (2)

---

**DISASSEMBLY**

- a. Position controller (1) on a clean flat surface.
- b. Circuit breaker.
  - (1) Remove self-locking screws (2) from switch plates (3) on circuit breakers (4).
  - (2) Detach switch plates from each circuit breaker.
  - (3) Loosen circuit breaker attaching screws.
  - (4) Disengage circuit breakers from connector assembly (5).
  - (5) Remove circuit breakers.

**REPAIR**

Repair of controller consists of replacing: circuit breaker (4).

**ASSEMBLY**

- a. Position controller (1) on a clean flat surface.
- b. Circuit breaker.
  - (1) Position circuit breaker (4) over connector assembly (5).

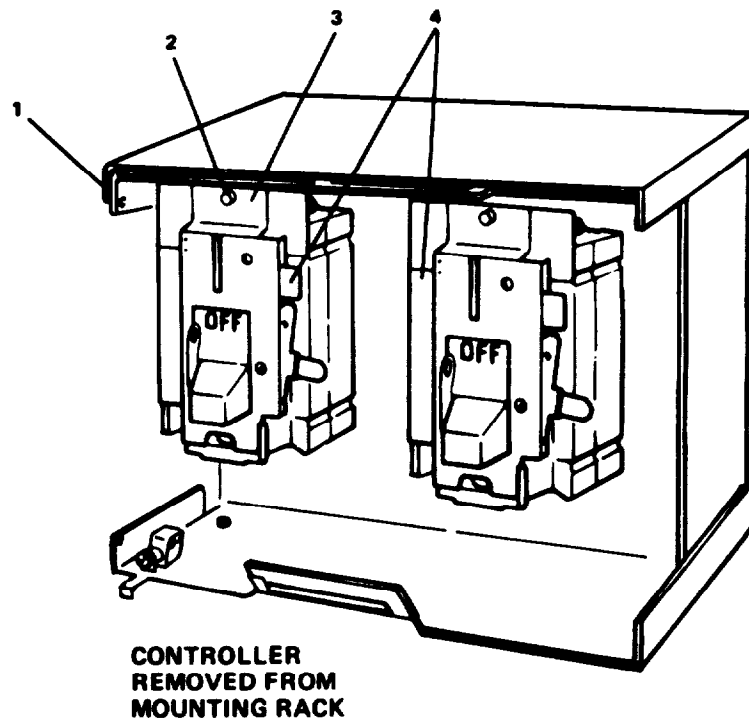
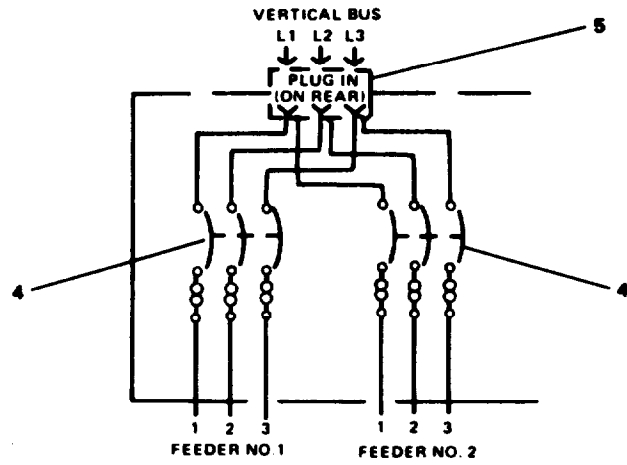


FIGURE 2-195. Controller (No. 1 & 7 SSDG Jacket Water Heater) Repair.

- (2) Engage circuit breakers to connect assembly.
  - (3) Secure circuit breakers to controller with attaching screws.
  - (4) Attach switch plates (3) to circuit breakers with self-locking screws (2).
- c. Controller replaced as specified in paragraph 2-224.

---

**2-226. Replace Motor Controller, Air Compressor No. 1 and No. 2.**

---

This task covers:      a. Removal,      b. Replacement.

---

**INITIAL SETUP****Tools**

Tool Kit, Electrician's,  
5180-00-391-1087

**Equipment Condition**

On Ship Service Switchboard Turned OFF  
At AUX MCHRY MCC Circuit Breaker and  
Tagged "Out of Service - Do Not Operate."

**Materials/Parts**

Warning Tags, Item 1, Appendix C

---

**REMOVAL**

Refer to paragraph 2-222.

**REPLACEMENT**

Refer to paragraph 2-222.

**2-227. Repair Motor Controller, Air Compressor No. 1 and No. 2.**

---

This task covers:      a. Disassembly,    b. Repair,    c. Assembly.

---

**INITIAL SETUP**

Tools

Tool Kit, Electrician's,  
5180-00-391-1087

Equipment Condition

Motor controller removed as specified  
in paragraph 2-222.

Materials/Parts

Motor Starter P/N A10D-2  
Armature P/N 48-1626  
Shunt Coil P/N 9-12526-1  
Contact Assembly P/N C320KB1  
Auxiliary Contact P/N C320KB2  
Transformer P/N 42-3537-9  
Cartridge Fuse P/N 44-576  
Circuit Breaker P/N HMCP050K2  
Lamps P/N 28-2202  
Electrical Contacts P/N 10250T51,  
P/N 10250153  
Thermal Heater P/N H1044  
Warning Tags, Item 1, Appendix C

---

**DISASSEMBLY**

Refer to paragraph 2-223.

**REPAIR**

Refer to replacement parts list.

**ASSEMBLY**

Refer to paragraph 2-223.



---

**2-228. Replace Motor Controller, Dirty Oil Pump.**

---

This task covers:      a. Removal,      b. Replacement.

---

**INITIAL SETUP****Tools**

Tool Kit, Electrician's,  
5180-00-391-1087

**Equipment Condition**

On Ship Service Switchboard Turn OFF  
AUX MCHRY MCC Circuit Breaker and Tag  
"Out of Service - Do Not Operate."

**Materials/Parts**

Warning Tags, Item 1, Appendix C

---

**REMOVAL**

Refer to paragraph 2-222.

**REPLACEMENT**

Refer to paragraph 2-222.

**2-229. Repair Motor Controller (Dirty Oil Pump).**

---

This task covers:      a. Disassembly,    b. Repair,    c. Assembly.

---

**INITIAL SETUP**

Tools

Tool Kit, Electrician's,  
5180-00-391-1087

Equipment Condition

Motor Controller, Dirty Oil Pump.  
Remove as specified in paragraph 2-222.

Materials/Parts

Motor Starter P/N A10C1  
Electrical Contact Kit P/N 6-23-2  
Lever Armature P/N 48-1019  
Electrical Coil P/N 9-1887-1  
Electrical Contact Assembly  
P/N C320KB1  
Auxiliary Contact P/N C320KB2  
Transformer P/N 42-3537  
Cartridge Fuse P/N 44-574  
Incandescent Lamp P/N 28-2202  
Circuit Breaker P/N HMCP015E0  
Thermal Heater P/N H1032  
Electrical Contact P/N 10250T51 &  
P/N 10250T53  
Warning Tags, Item 1, Appendix C

---

**DISASSEMBLY**

Refer to paragraph 2-223.

**REPAIR**

Refer to replacement parts list.

**ASSEMBLY**

Refer to paragraph 2-223.

**2-230. Repair Motor Controller, Main Engine Jacket Water Heater No. 1 and No. 2.**

This task covers:      a. Removal,      b. Replacement.

**INITIAL SETUP**

Tools

Tool Kit, Electrician's,  
5180-00-391-1087

Equipment Condition

On Ship Service Switchboard Turn OFF  
AUX MCHRY MCC Circuit Breaker and  
Tag "Out of Service - Do Not Operate."

Materials/Parts

Warning Tags, Item 1, Appendix C

**REMOVAL**

Refer to paragraph 2-224.

**REPLACEMENT**

Refer to paragraph 2-224.

**2-231. Repair Controller, Main Engine Jacket Water Heater No. 1 and No. 2.**

---

This task covers:      a. Disassembly,    b. Repair,    c. Assembly.

---

**INITIAL SETUP**

Tools

Tool Kit, Electrician's,  
5180-00-391-1087

Equipment Condition

Controller removed as specified in paragraph 2-224.

Materials/Parts

Circuit Breaker P/N B3025V

---

**DISASSEMBLY**

Refer to paragraph 2-225.

**REPAIR**

Refer to replacement parts list.

**ASSEMBLY**

Refer to paragraph 2-225.

**2-232. Repair/Replace Motor Control Center, Auxiliary Machinery Vent Room No. 1**

This task covers: a. Removal, b. Replacement.

**INITIAL SETUP**

Tools

Tool Kit, Electrician's,  
5180-00-391-1087

Equipment Condition

On Ship Service Switchboard Turn OFF  
AUX MCHRY MCC Circuit Breaker and  
Tag "Out of Service - Do Not Operate."  
Following Motor Controllers Removed as  
Specified in Paragraphs 2-222 and 224.  
L.O. Emergency Prelube Pump No. 1 And No. 2.  
Air Compressor No. 1 and No. 2.  
Main Engine Jacket Water Heater No. 1 and No. 2.  
SSDG Jacket Water Heater No. 1 and No. 2.

Materials/Parts

Warning Tags, Item 1, Appendix C

**REMOVAL**

**NOTE**

**The following procedure describes actions required to make Auxiliary Machinery Vent No. 1 Motor Control Center ready for removal from vessel.**

- a. Remove associated hardware from top cover panel (2, FIGURE 2-196) and remove panel.
- b. Tag and disconnect all incoming wiring (1) to controller bus bars and terminals.
- c. Remove associated hardware anchoring motor control center (3) to metal deck mounting pads.

**NOTE**

**Several crew members are required to remove controller unit (3) from its mounted position.**

- d. Lift motor control center (3) up from mounting pads and place on engine room deck.

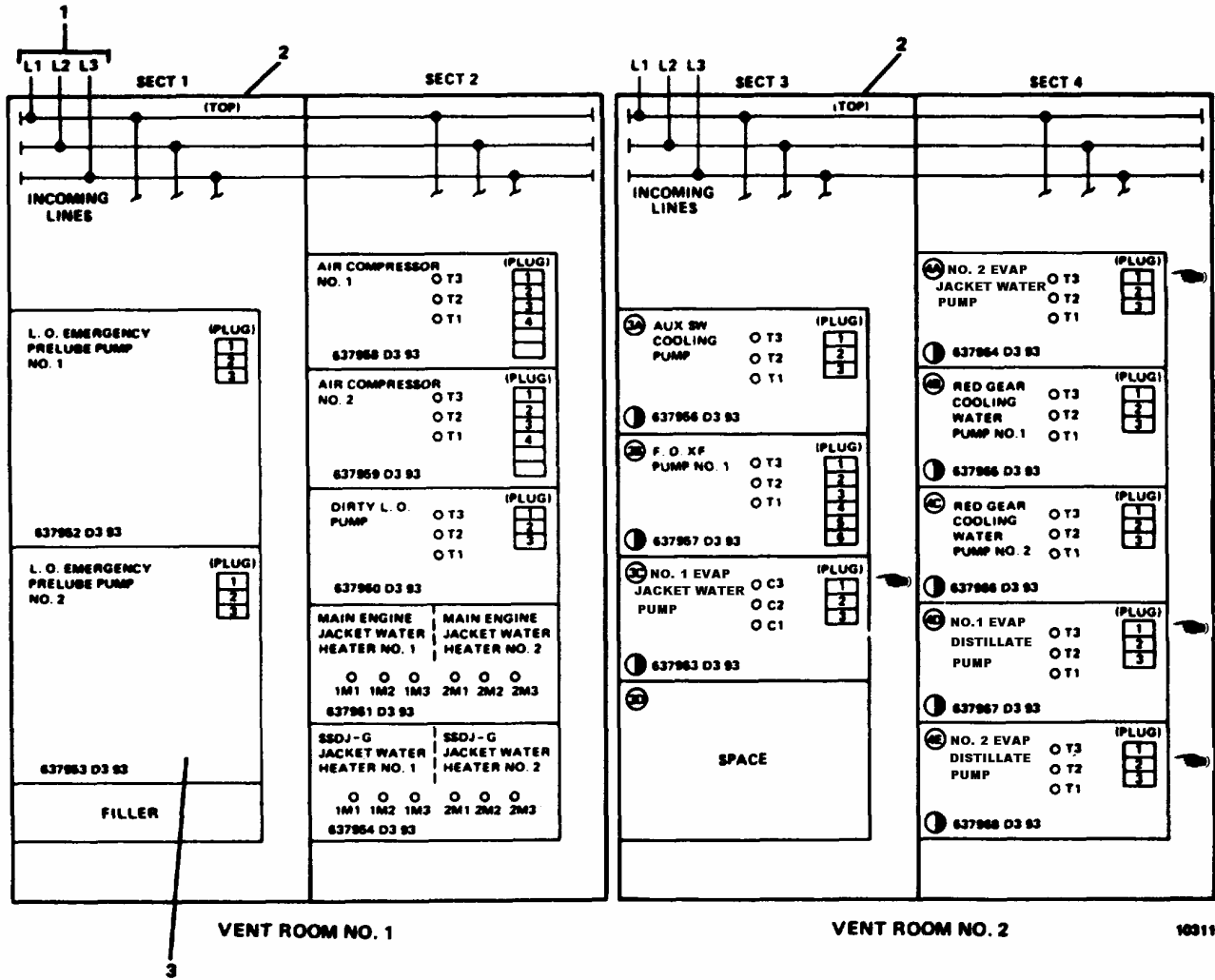


Figure 2-196. MCC Auxiliary Machinery Vent No. 1 and No. 2.

**REPLACEMENT.**

**NOTE**

**The following procedure describes actions required to complete installation of Auxiliary Machinery Vent No. 1 Motor Control Center once the motor control center has been placed into position in vessel.**

- a. Install motor control center (3) on deck mounting pad with associated hardware.
- b. Connect incoming wiring (1) to controller bus bars and terminals.
- c. Install top cover panel (2) with associated hardware.
- d. Install removed motor controllers as specified in paragraphs 2-222 and 2-224.

**2-233. Replace/Repair Motor Control Center, Auxiliary Machinery Vent Room No. 2. (FIGURE 2-197)**

---

This task covers:      a. Removal,      b. Repair,      c. Replacement.

---

**INITIAL SETUP**

Tools

Tool Kit, Electrician's,  
5180-00-391-1087

Equipment Condition

On Ship Service Switchboard Turn OFF AUX  
MCHRY MCC and Tag "Out of Service - Do Not  
Operate."

Materials/Parts

Refer To Motor Controller/  
Controller Being Serviced.  
Warning Tags, Item 1, Appendix C

---

**REMOVAL**

- a. Motor controller, Auxiliary Sea Water Cooling Pump. Refer to paragraph 2-234.
- b. Motor controller, Fuel Oil Transfer Pump No. 1. Refer to paragraph 2-236.
- c. Motor Controller, Evaporator Jacket Water Pump No. 1 and No. 2. Refer to paragraph 2-238.
- d. Motor Controller, Evaporator Distillate Pump No. 1 and No. 2. Refer to paragraph 2-240.
- e. Motor controller, Reduction Gear Cooling Water Pump No. 1 and No. 2. Refer to paragraph 2-242.
- f. Motor controller, Clean Lube Oil Pump. Refer to paragraph 2-244.
- g. Motor Control Center, Auxiliary Machinery Vent No. 2. Refer to paragraph 2-246.

**REPAIR**

Refer to replacement parts list of motor controller/controller being serviced.

**REPLACEMENT**

- a. Motor Control Center, Auxiliary Machinery Vent No. 2. Refer to paragraph 2-246.



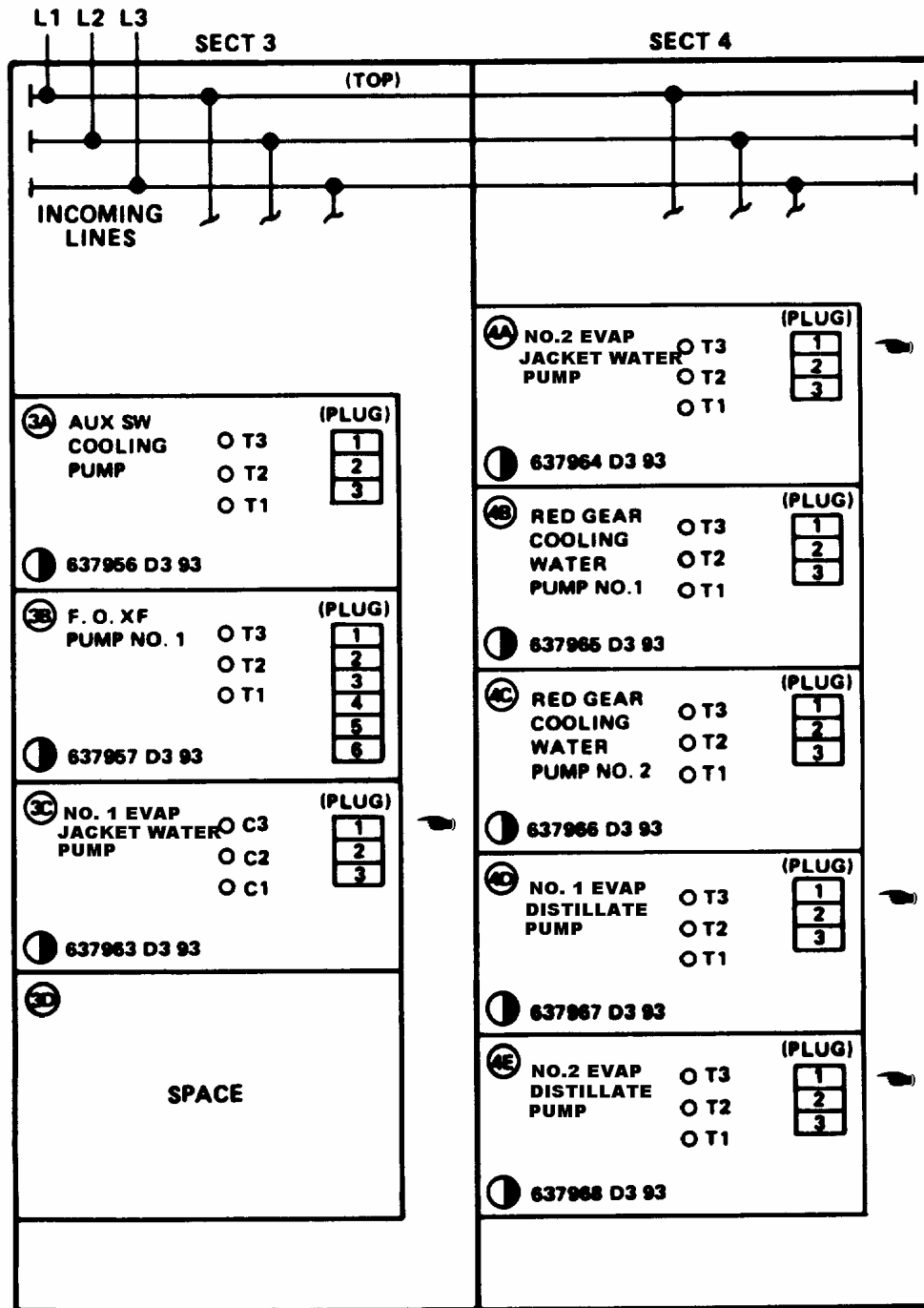


Figure 2-197. Motor Control Center. Auxiliary Machinery Room Vent No. 2.

**TM 55-1905-223-24-18-1**

- b. Motor controller, Clean Lube Oil Pump No. 1 and No. 2. Refer to paragraph 2-244.
- c. Motor controller, Reduction Gear Cooling Water Pump No. 1 and 2. Refer to paragraph 2-242.
- d. Motor Controller, Evaporator Jacket Water Pump No. 1 and No. 2. Refer to paragraph 2-238.
- e. Motor Controller, Evaporator Distillate Pump No. 1 and No. 2. Refer to paragraph 2-240.
- f. Motor controller, Fuel Oil Transfer Pump. Refer to paragraph 2-236.
- g. Motor controller, Auxiliary Sea Water Cooling Pump. Refer to paragraph 2-234.
- h. On ship service switchboard turn ON AUX MCHRY MCC circuit breaker and remove tag.

---

**2-234. Replace Motor Controller, Auxiliary Sea Water Cooling Pump.**

---

This task covers:      a. Removal,      b. Replacement.

---

**INITIAL SETUP****Tools**

Tool Kit, Electrician's,  
5180-00-391-1087

**Equipment Condition**

On Ship Service Switchboard Turn OFF AUX  
MCHRY MCC and Tag "Out of Service - Do Not  
Operate."

**Materials/Parts**

Warning Tags, Item 1, Appendix C

---

**REMOVAL**

Refer to paragraph 2-222.

**REPLACEMENT**

Refer to paragraph 2-222.

**2-235. Repair Motor Controller, Auxiliary Sea Water Cooling Pump.**

---

This task covers:      a. Disassembly,    b. Repair,    c. Assembly.

---

**INITIAL SETUP**

Tools

Tool Kit, Electrician's,  
5180-00-391-1087

Equipment Condition

Controller removed as specified in paragraph 2-222.

Materials/Parts

Motor Starter, P/N A10C-1  
Electrical Contact Kit, P/N 6-23-2  
Lever Armature, 48-1019  
Electrical Coil, 9-1887-1  
Electrical Contact Assembly,  
P/N C320RB1  
    Auxiliary Contact, P/N C320RB2  
Transformer, P/N 42-3537  
Cartridge Fuse, P/N 44-574  
Circuit Breaker, HMCP0030H1  
Incandescent Lamp, P/N 28-2202  
Electrical Contact, P/N 10250T53,  
    P/N 1020T51  
Thermal Heater, P/N H1043  
Warning Tags, Item 1, Appendix C

---

**DISASSEMBLY**

Refer to paragraph 2-223.

**REPAIR**

Refer to replacement parts list.

**ASSEMBLY**

Refer to paragraph 2-223.

---

**2-236. Replace Motor Controller, Lube Oil Transfer Pump No. 1.**

---

This task covers:      a. Removal,      b. Replacement.

---

**INITIAL SETUP****Tools**

Tool Kit, Electrician's,  
5180-00-391-1087

**Equipment Condition**

■ On Ship Service Switchboard Turn OFF  
AUX MCHRY MCC Circuit Breaker and  
Tag "Out of Service - Do Not Operate."

**Materials/Parts**

Warning Tags, Item 1, Appendix C

---

**REMOVAL**

Refer to paragraph 2-224.

**REPLACEMENT**

Refer to paragraph 2-224.

**2-237. Repair Motor Controller, Lube Oil Transfer Pump No. 1.**

---

This task covers:      a. Disassembly,    b. Repair,    c. Assembly.

---

**INITIAL SETUP**

Tools

Tool Kit, Electrician's,  
5180-00-391-1087

Equipment Condition

Controller removed as specified in paragraph 2-224.

Materials/Parts

Motor Starter, P/N A10C-1  
Electrical Contact Kit, P/N 6-23-2  
Lever Armature P/N 48-1019  
Electrical Coil, P/N 9-1887-1  
Electrical Contact Assembly,  
P/N C320RB1  
Auxiliary Contact, P/N C320RB2  
Transformer, P/N 42-3537  
Cartridge Fuse, 44-574  
Circuit Breaker, P/N HMCP007C0  
Incandescent Lamp, P/N 28-2202  
Electrical Contact, P/N 10250T53,  
P/N 10250TS1  
Thermal Heater, P/N H1026  
Warning Tags, Item 1, Appendix C

---

**DISASSEMBLY**

Refer to paragraph 2-223.

**REPAIR**

Refer to replacement parts list.

**ASSEMBLY**

Refer to paragraph 2-223.

---

**2-238. Replace Controller, Evaporator Jacket Water Pump No. 1 and No. 2.**

---

This task covers:      a. Removal,      b. Replacement.

---

**INITIAL SETUP****Tools**

Tool Kit, Electrician's,  
5180-00-391-1087

**Equipment Condition**

On Ship Service Switchboard Turn OFF AUX  
MCHRY MCC and Tag "Out of Service - Do Not  
Operate."

**Materials/Parts**

Warning Tags, Item 1, Appendix C

---

**REMOVAL**

Refer to paragraph 2-222.

**REPLACEMENT**

Refer to paragraph 2-222.

**2-239. Repair Controller, Evaporator Jacket Water Pump No.1 and No. 2.**

---

This task covers:      a. Disassembly,      b. Repair,      c. Assembly.

---

**INITIAL SETUP**

Tools

Tool Kit, Electrician's,  
5180-00-391-1087

Equipment Condition

Controller removed as specified  
in paragraph 2-222.

Materials/Parts

Motor Starter P/N A10C-1  
Electrical Contact Kit P/N 6-23-2  
Lever Armature P/N 48-1019  
Electrical Coil P/N 9-1887-1  
Electrical Contact Assembly P/N C320KB1  
Auxiliary Contact P/N C320KB2  
Transformer P/N 42-3537  
Cartridge Fuse P/N 44-574  
Circuit Breaker P/N FB3015V  
Incandescent Lamp P/N 28-2202  
Thermal Heater P/N H1041  
Warning Tags, Item 1, Appendix C

---

**DISASSEMBLY**

Refer to paragraph 2-223.

**REPAIR**

Refer to replacement parts list.

**ASSEMBLY**

Refer to paragraph 2-223.



---

**2-240. Replace Controller, Evaporator Distillate Pump No.1 and No. 2**

---

This task covers:      a. Removal,      b. Replacement.

---

**INITIAL SETUP****Tools**

Tool Kit, Electrician's,  
5180-00-391-1087

**Equipment Condition**

On Ship Service Switchboard Turn OFF AUX  
MCHRY MCC and tag "Out of Service - Do Not  
Operate."

**Materials/Parts**

Warning Tags, Item 1, Appendix C

---

**REMOVAL**

Refer to paragraph 2-222.

**REPLACEMENT**

Refer to paragraph 2-222.

**2-241 Repair Controller, Evaporator Distillate Pump No.1 and No. 2.**

---

This task covers: a. Disassembly, b. Repair, c. Assembly.

---

**INITIAL SETUP**

Tools

Tool Kit, Electrician's,  
5180-00-391-1087

Equipment Condition

Controller removed as specified  
in paragraph 2-222.

Materials/Parts

Meter, Elapsed Time Relay P/N 5120-2200  
Motor Starter P/N A10C-1  
Electrical Contact Kit P/N 6-23-2  
Lever Armature P/N 48-1019  
Electrical Coil P/N 9-1887-1  
Electrical Contact Assembly P/N C320KB1  
Auxiliary Contact P/N C320KB2  
Transformer P/N 42-3537  
Cartridge Fuse P/N 44-574  
Circuit Breaker P/N FB3015V  
Incandescent Lamp P/N 28-2202  
Thermal Heater P/N H1041  
Warning Tags, Item 1, Appendix C

---

**NOTE**

Refer to FIGURE 2-198, to compare differences in component  
arrangement of Elapsed Time Meter used.

**DISSASSEMBLY**

Refer to paragraph 2-223.

**REPAIR**

Refer to replacement parts list.

**ASSEMBLY**

Refer to paragraph 2-223.

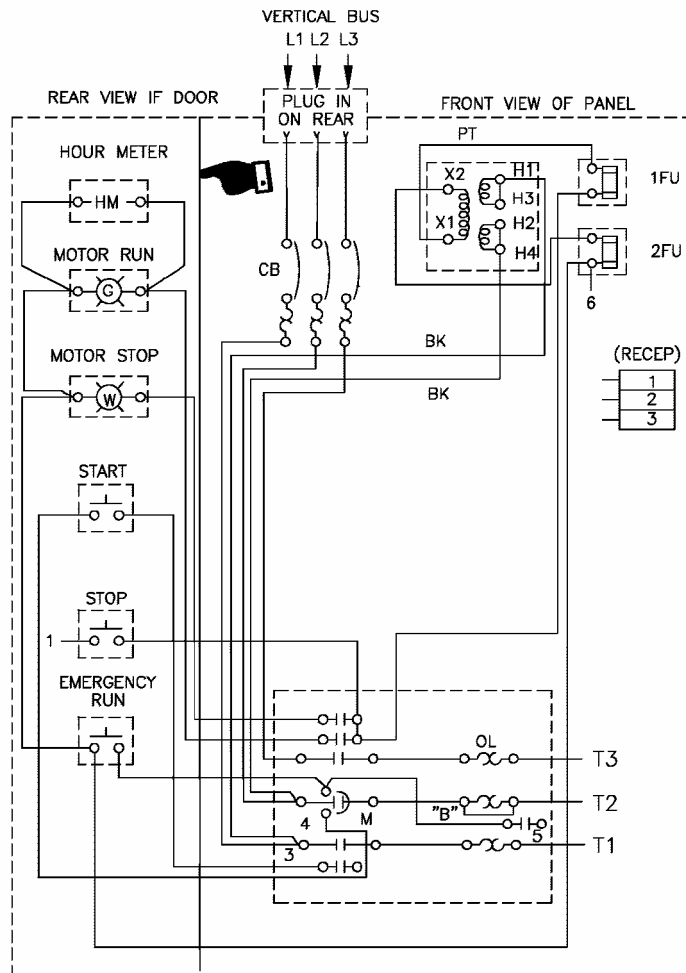


Figure 2-198. Controller, Evaporator Distillate Pump 1 and 2.

**NOTE**

Page 2-784 deleted due to Waste Heat Evaporator upgrade MWO 55-1905-223-55-3.



---

**2-242. Replace Motor Controller, Reduction Gear Cooling Water Pump No. 1 and No. 2.**

---

This task covers:   a. Removal,           b. Replacement.

---

**INITIAL SETUP****Tools**

Tool Kit, Electrician's,  
5180-00-391-1087

**Materials/Parts**

Warning tags, Item 1, Appendix C

---

**Equipment Condition**

On Ship Service Switchboard Turn OFF  
AUX MCHRY MCC Circuit Breaker and  
Tag "Out of Service - Do Not  
Operate."

**REMOVAL**

Refer to paragraph 2-222.

**REPLACEMENT**

Refer to paragraph 2-222.

**2-243. Repair Controller, Reduction Gear Cooling Water Pump No. 1 and No. 2.**

---

This task covers: a. Disassembly, b. Repair, c. Assembly.

---

**INITIAL SETUP**

Tools

Tool Kit, Electrician's,  
5180-00-391-1087

Equipment Condition

Controller removed as specified  
in paragraph 2-222.

Materials/Parts

Motor Starter, P/N A10C-1  
Electrical Contact Kit, P/N 6-23-2  
Lever Armature, P/N 48-1019  
Electrical Coil, P/N 9-1887-1  
Electrical Contact Assembly,  
P/N C320KR1  
Auxiliary Contact, P/N C320KB2  
Transformer, P/N 42-3537  
Cartridge Fuse, P/N 44-574  
Circuit Breaker, P/N HMCP015E0  
Incandescent Lamp, P/N 28-2202  
Electrical Contact, P/N 10250T53,  
P/N 10250T51  
Thermal Heater, P/N H1032  
Warning Tags, Item 1, Appendix C

---

**DISASSEMBLY**

Refer to paragraph 2-223.

**REPAIR**

Refer to replacement parts list.

**ASSEMBLY**

Refer to paragraph 2-223.

**2-244. Replace Motor Controller, Clean Lube Oil Pump No. 1 and No. 2.**

This task covers: a. Removal, b. Replacement.

**INITIAL SETUP**

Tools

Tool Kit, Electrician's,  
5180-00-391-1087

Equipment Condition

On Ship Service Switchboard Turn Off  
AUX MCHRY MCC Circuit Breaker and Tag  
"Out of Service - Do Not  
Operate."

Materials/Parts

Warning Tags, Item 1, Appendix C

**REMOVAL**

Refer to paragraph 2-222.

**REPLACEMENT**

Refer to paragraph 2-222.

**2-245. Repair Motor Controller, Clean Lube Oil Pump No. 1 and No. 2.**

---

This task covers: a. Disassembly, b. Repair, c. Assembly.

---

**INITIAL SETUP**

Tools

Tool Kit, Electrician's,  
5180-00-391-1087

Equipment Condition

Controller removed as specified  
in paragraph 2-222.

Materials/Parts

Motor Starter, P/N A10C-1  
Electrical Contact Kit, P/N 6-23-2  
Lever Armature, P/N 48-1019  
Electrical Coil, P/N 9-1887-1  
Electrical Contact Assembly,  
P/N C320RB1  
Auxiliary Contact, P/N C320K32  
Transformer, P/N 42-3537  
Cartridge Fuse, P/N 44-574  
Circuit Breaker, P/N HMCP050E0  
Incandescent Lamp, P/N 28-2202  
Electrical Contact, P/N 10250T53, P/N  
10250T51  
Thermal Heater, P/N H1032  
Warning Tags, Item 1, Appendix C

---

**DISASSEMBLY**

Refer to paragraph 2-223.

**REPAIR**

Refer to replacement parts list.

**ASSEMBLY**

Refer to paragraph 2-223.



**2-246. Repair/Replace Motor Control, Center, Auxiliary Machinery Vent Room No. 2.**

This task covers:      a. Removal,      b. Replacement.

**INITIAL SETUP**

Tools

Tool kit, electrician's,  
5180-00-391-1087

Materials/Parts

Warning Tags, Item 1, Appendix C

Equipment Condition

On Ship Service Switchboard Turn OFF AUX  
MCHRY MCC Circuit Breaker and Tag "Out of  
Service - Do Not Operate."

Following Motor Controllers Removed as Specified In  
Paragraph 2-222.

Auxiliary Sea Water Cooling Pump.

Fuel Oil Transfer Pump No. 1.

Evaporator Jacket Water Pump No. 1 and No. 2.

Evaporator Distillate Pump No. 1 and No. 2.

Reduction Gear Cooling Water Pump No. 1  
and No. 2.

Clean Lube Oil Pump No. 1 and No. 2.

**REMOVAL**

Refer to paragraph 2-232.

**REPLACEMENT**

Refer to paragraph 2-232.

**2-247. Replace/Repair Motor Control Center, Engine Room Vent. (FIGURE 2-199)**

---

This task covers: a. Removal, b. Repair, c. Replacement.

---

**INITIAL SETUP**

Tools

Refer To Motor Controller Being Serviced.

Equipment Condition

On Ship Service Switchboard Turn OFF ENG RM VENT MCC Circuit Breaker and Tag "Out of Service - Do Not Operate."

Materials/Parts

Refer To Motor Controller Being Serviced.  
Warning Tags, Item 1, Appendix C

---

**REMOVAL**

- a. Motor controller, Engine Room Exhaust Fan. Refer to paragraph 2-248.
- b. Motor controller, Engine Room Supply Fan. Refer to paragraph 2-250.
- c. Motor Control Center Engine Room Vent. Refer to paragraph 2-252.

**REPAIR**

Refer to replacement parts list of motor controller being serviced.

**REPLACEMENT**

- a. Motor Control Center Engine Room Vent. Refer to paragraph 2-248.
- b. Motor controller, Engine Room Supply Fan. Refer to paragraph 2-250.
- c. Motor controller, Engine Room Exhaust Fan. Refer to paragraph 2-252.
- d. On ship service switchboard turn ON ENG RM VENT MCC circuit breaker and remove tag.

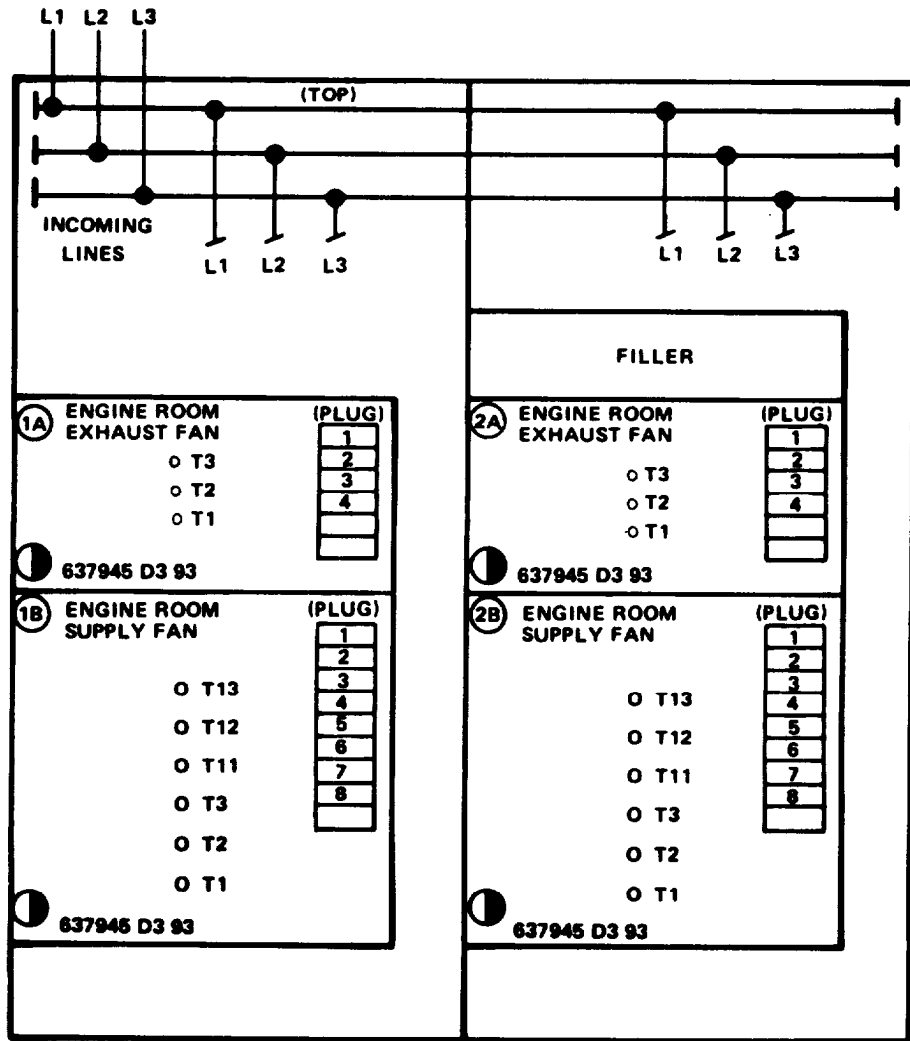


FIGURE 2-199. Motor Control Center Engine Room Vent.

---

2-248. Replace Motor Controller, Engine Room Exhaust Fan.

---

This task covers: a. Removal, b. Replacement.

---

### INITIAL SETUP

#### Tools

■ Tool kit, electrician's,  
5180-00-391-1087

#### Materials/Parts

Warning tags, Item 1, Appendix C

---

#### Equipment Condition

On ship service switchboard turn OFF  
AUX MCHRY MCC circuit breaker and  
tag "Out of Service - Do Not  
Operate."

### REMOVAL

Refer to paragraph 2-222.

### REPLACEMENT

Refer to paragraph 2-222.

---

**2-249. Repair Controller, Engine Room Exhaust Fan.**

---

This task covers: a. Disassembly, b. Repair, c. Assembly.

---

**INITIAL SETUP****Tools**

Tool Kit, Electrician's,  
5180-00-391-1087

**Equipment Condition**

Controller removed as specified  
in paragraph 2-222.

**Materials/Parts**

Motor Starter, P/N A10D-2  
Electrical Contact Kit, P/N 6-34-2  
Lever Armature, P/N 48-1626  
Electrical Coil, P/N 9-2526-1  
Electrical Contact Assembly,  
P/N C32-0KB1  
Auxiliary Contact, P/N C320KB2  
Transformer, P/N 42-3537-9  
Cartridge Fuse, P/N 44-576  
Circuit Breaker, P/N HMCP050K2  
Incandescent Lamp, P/N 28-2202  
Electrical Contact, P/N 10250T53  
P/N 10250T51  
Thermal Heater, P/N H1048  
Warning Tags, Item 1, Appendix C

---

**DISASSEMBLY**

Refer to paragraph 2-223.

**REPAIR**

Refer to replacement parts list.

**ASSEMBLY**

Refer to paragraph 2-223.

**2-250. Replace Motor Controller, Engine Room Supply Fan. (FIGURE 2-200)**

---

This task covers: a. Removal, b. Replacement.

---

**INITIAL SETUP**

Tools

Tool Kit, Electrician's,  
5180-00-391-1087

Materials/Parts

Warning Tags, Item 1, Appendix C

---

Equipment Condition

On Ship Service Switchboard Turn OFF  
Engine Room Vent MCC Circuit Breaker  
and Tag, "Out of Service - Do Not  
Operate."

**REMOVAL**

**NOTE**

Procedures for **REMOVAL** of the Engine Room Supply Fan are basically the same as those described in paragraph 2-222 and illustrated in FIGURE 2-192. For configuration variance of the Engine Room Supply Fan refer to FIGURE 2-200.

**REPLACEMENT**

**NOTE**

Procedures for **REPLACEMENT** of the Engine Room Supply Fan are basically the same as those described in paragraph 2-222 and illustrated in FIGURE 2-192. For configuration variance of the Engine Room Supply Fan refer to FIGURE 2-200.

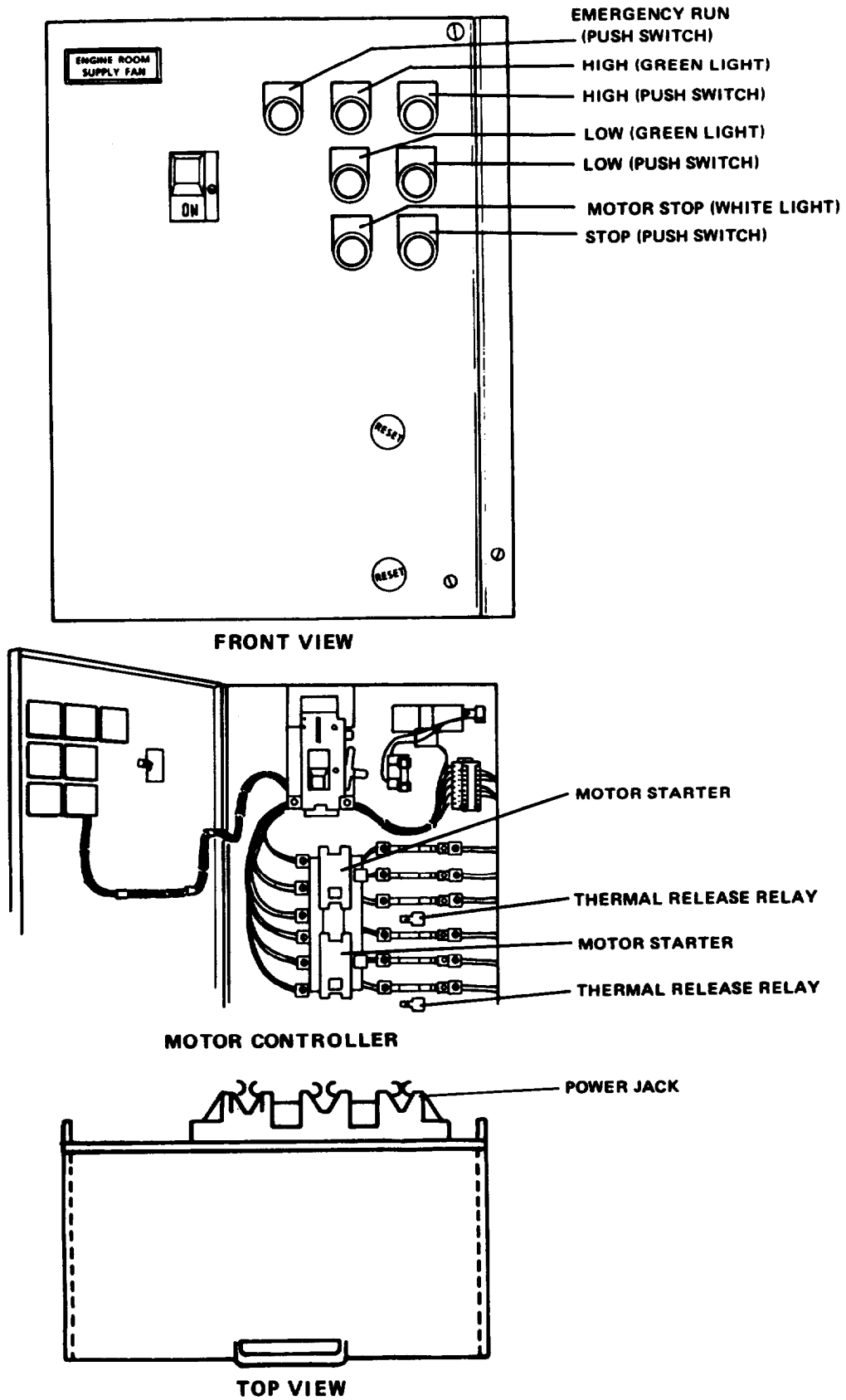


FIGURE 2-200. Motor Controller (Engine Room Supply Fan) Replace.

---

2-251. Repair Motor Control, Center Engine Room Supply Fan. (FIGURE 2-201, Sheets 1 - 3)

---

This task covers: a. Disassembly, b. Repair, c. Assembly.

---

### INITIAL SETUP

#### Tools

Tool kit, electrician's,  
5180-00-391-1087

#### Equipment Condition

Motor controller removed as specified  
in paragraph 2-222.

### Materials/Parts

Motor starter, P/N A10D-2  
Electrical contact kit, P/N 6-34-2  
Armature lever relay, P/N 48-1626  
Electrical coil, P/N 9-2526-1  
Electrical contact assembly,  
P/N C320KR1  
Auxiliary contact, P/N C320KB2  
Transformer, P/N 42-3537-9  
Fuse cartridge, P/N 44-576  
Circuit breaker, P/N HMCP-050K2  
Incandescent lamps, P/N 28-2202  
Electrical contacts, P/N 10250T51,  
P/N 10250T53  
Thermal heaters, P/N H1049  
Warning tags, Item 1, Appendix C

---

### DISASSEMBLY

- a. Position motor controller (34, FIGURE 2-201, Sheet 1) on a clean flat surface.
- b. Motor starter.
  - (1) Remove three mounting screws from motor starter (19, FIGURE 2-193, Sheet 2).
  - (2) Lift motor starter out of motor controller (34).
- c. Electrical contact kit.
  - (1) Position motor starter on a clean flat surface.
  - (2) Loosen two cover screws (33, FIGURE 2-201, Sheet 2) on electrical contact kit (24). Remove cover.
  - (3) Lift armature lever relay (31) out of each slot on armature lever relay push bars. Note position of armature lever relay for assembly.



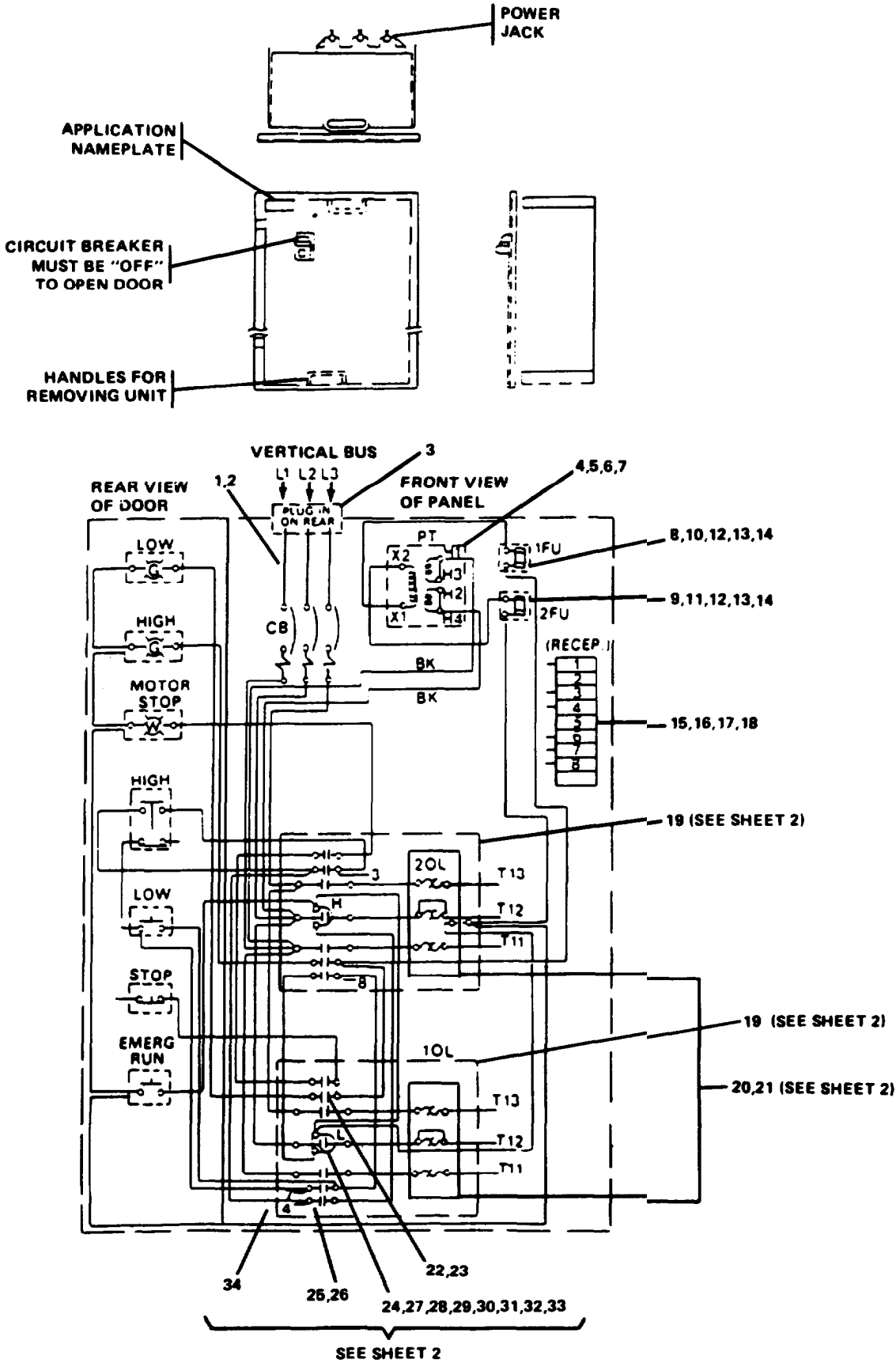


FIGURE 2-201. Motor Controller. Engine Room Supply Fan. Sheet 1 of 3.

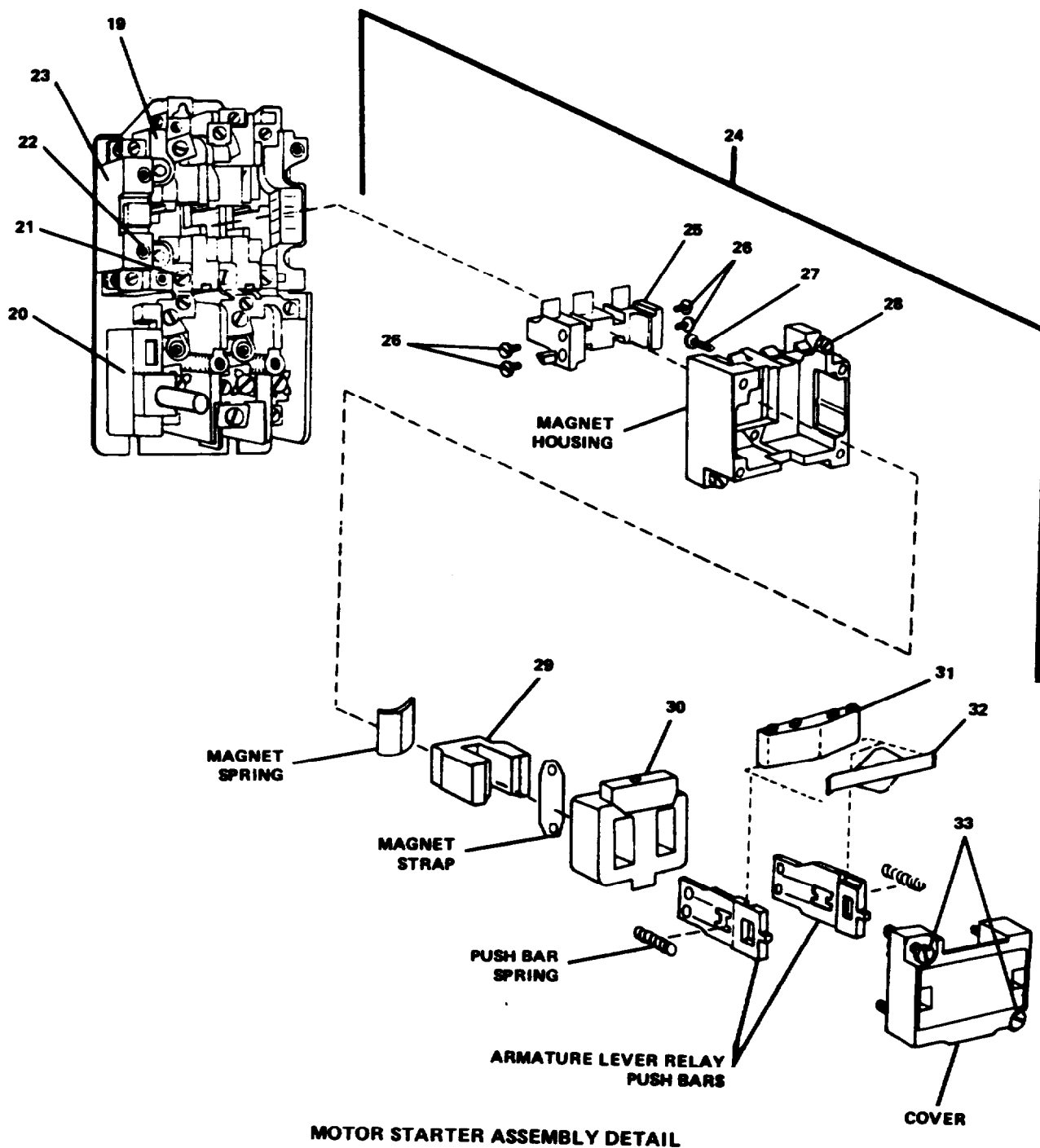


FIGURE 2-201. Motor Controller. Engine Room Supply Fan. Sheet 2 of 3.

- (4) Detach and remove armature spring plate (32) from slotted ends of each armature lever relay push bar.
  - (5) Remove electrical coil (30) by unplugging from socket on magnet housing of electrical contact kit (24).
  - (6) Remove two hex head screws (28) securing magnet housing to motor starter (20).
  - (7) Separate magnet housing from motor starter.
  - (8) Remove two machine screws (27) securing magnet spring and magnet frame (29) to magnet strap.
  - (9) Remove magnet strap, magnet frame (29) and magnet spring from magnet housing.
- d. Electrical contact assembly.
- (1) Remove four machine screws (26) securing electrical contact assembly (25) to each side of armature lever relay push bars.
  - (2) Separate electrical contact assembly at rear of magnet housing.
  - (3) Withdraw armature lever relay push bars from front of magnet housing. Note position of push bars for assembly.
  - (4) Compress and remove push bar springs from spring slots on each armature lever relay push bar.
- e. Thermal release relay.
- (1) Remove three machine screws (21) from thermal release relay (20).
  - (2) Position thermal release relay with control circuit wire exposed.
  - (3) Tag and disconnect control circuit wire.
  - (4) Remove thermal release relay.
- f. Auxiliary contact.
- (1) Loosen two screws (22) on auxiliary contact (23).
  - (2) Disconnect auxiliary contact from motor starter (19).
  - (3) Repeat steps (1) and (2) for removal of auxiliary contact on opposite side of motor starter, if applicable, if applicable.
- g. Transformer;
- (1) Tag and disconnect electrical leads from transformer (4, FIGURE 2-201, Sheet 1).
  - (2) Remove four hex plain nuts (5), lockwashers (6) and machine screws (7) from transformer.

(3) Lift transformer out of motor controller (34).

h. Fuseholder block.

(1) Tag and disconnect electrical leads from fuse blocks (8) and (9).  
(Internal wiring).

(2) Remove fuse cartridges (10 and 11).

(3) Remove two plain hex nuts (12), lockwashers (13) and machine screws (14)  
from each fuse block.

(4) Remove fuse blocks.

i. Terminal block (receptacle).

(1) Tag and disconnect electrical leads from terminal block (15). (Internal  
wiring).

(2) Remove two plain hex nuts (16), lockwashers (17) and machine screws (18)  
from each terminal block.

(3) Remove terminal block (15).

j. Circuit breaker.

(1) Tag and disconnect electrical leads from circuit breaker (1). (Internal  
wiring).

(2) Remove self-locking screw (2) and detach switch cover.

(3) Loosen circuit breaker mounting screws.

(4) Separate circuit breaker (1) from connector assembly (3).

(5) Lift circuit breaker out of motor controller.

k. Push switches/indicator lights. FIGURE 2-201 (Sheet 3 of 3)

(1) Position motor controller door (35) on a clean flat surface.

(2) Remove two screws from protective cover over each push switch and  
indicator light at rear of door.

(3) Remove protective covers.

(4) Push switches.

(a) Push switch (36).

1 Tag and disconnect electrical leads from push switch (36) at rear of  
door.

2 Unscrew locknut (38) from push switch at front of door.

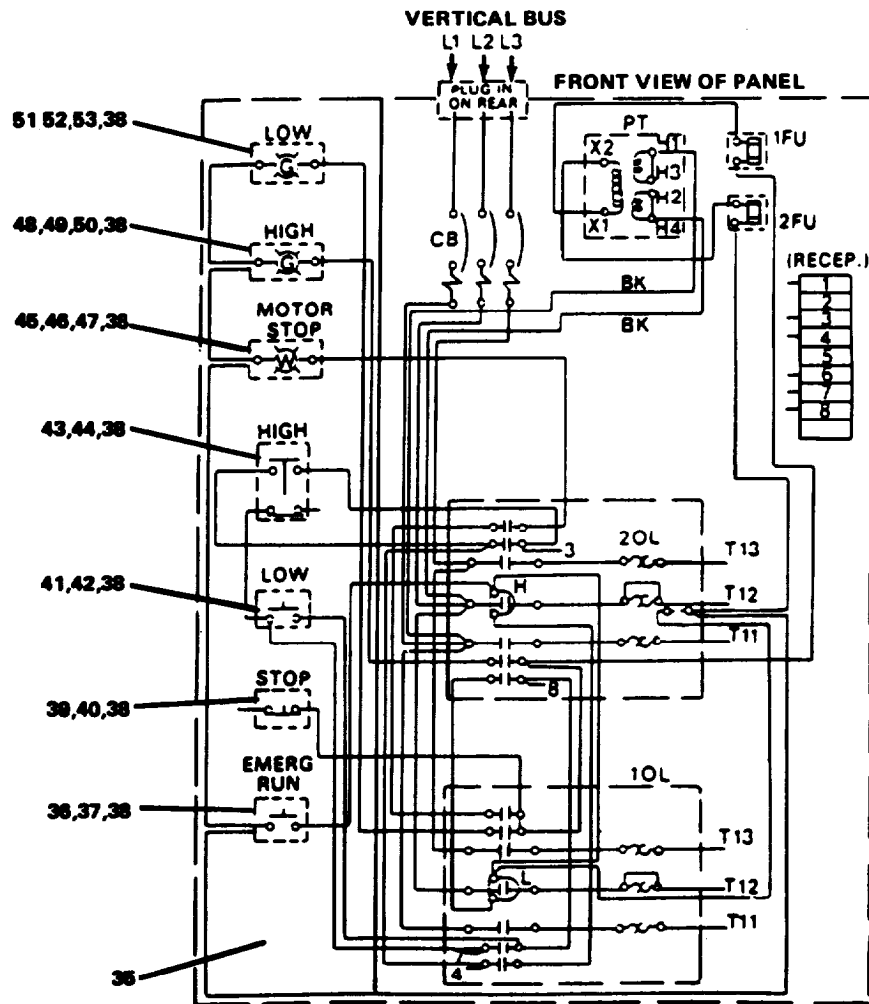


FIGURE 2-201. Motor Controller. Engine Room Supply Fan. Sheet 3 of 3.

3 Remove push switch and electrical contact (37) from rear of door.

(b) Push switch (39).

Refer to steps (a) 1 through 3 to remove push switch (39) and electrical contact (40).

(c) Push switch (41).

Refer to steps (a) 1 through 3 to remove push switch (41) and electrical contact (42).

(d) Push switch (43).

Refer to steps (a) 1 through 3 to remove push switch (43) and electrical contact (44).

(5) Indicator lights.

(a) Indicator light (45).

1 Unscrew light lens (46) from indicator light at front of door.

2 Remove incandescent lamp (47).

3 Tag and disconnect electrical leads from transformer assembly (120V) on indicator light (45) at rear of door.

4 Unscrew locknut (38) from indicator light (45) at front of door.

5 Remove indicator light (45) from door.

(b) Indicator light (48).

1 Unscrew light lens (49) from indicator light at front of door.

2 Remove incandescent lamp (50).

3 Tag and disconnect electrical leads from indicator light (48) at rear of door.

4 Unscrew locknut (38) from indicator light (48) at front of door.

5 Remove indicator light (48) from door.

(c) Indicator light (51).

1 Unscrew light lens (52) from indicator light at front of door.

2 Remove incandescent lamp (53).

3 Tag and disconnect electrical leads from indicator light (51) at rear of door.

4 Unscrew locknut (38) from indicator light (51) at front of door.

5 Remove indicator light (51) from door.

### REPAIR

Repair at motor controller consists of replacing: motor starter (19), electrical contact kit (24), armature lever relay (31), electrical coil (30), electrical contact assembly (25), auxiliary contact (23), transformer (4), fuse cartridge (10, 11), circuit breaker (1), incandescent lamp (47, 50, 53), electrical contact (37, 40, 42, 44), thermal relay heater (20).

### ASSEMBLY

- a. Position motor controller door (34) on a clean flat surface.
- b. Indicator lights/push switches. FIGURE 2-201 (Sheet 3).

(1) Indicator lights.

(a) Indicator light (51).

- 1 Position indicator light (51) in door.
- 2 Install locknut (38) on indicator light (51) at front of door.
- 3 Connect electrical leads to indicator light (51) at rear of door. Remove tags.
- 4 Install incandescent lamp (53).
- 5 Install light lens (52) on indicator light at front of door.

(b) Indicator light (48).

- 1 Position indicator light (48) in door.
- 2 Install locknut (38) on indicator light (48) at front of door.
- 3 Connect electrical leads to indicator light (48) at rear of door. Remove tags.
- 4 Install incandescent lamp (50).
- 5 Install light lens (49) on indicator light at front of door.

(c) Indicator light (45).

- 1 Position indicator light (45) in door.
- 2 Install locknut (38) on indicator light (45) at front of door.
- 3 Connect electrical leads to indicator (45) at rear door. Remove tags.
- 4 Install incandescent lamp (47).

1. Install light lens (46) on indicator light at front of door.
- (2) Push switches.
  - (a) Push switch (43).
    - 1 Position push switch and electrical contact (44) at rear of door.
    - 2 Install locknut (38) on push switch.
    - 3 Connect electrical leads to push switch at rear of door. Remove tags.
  - (b) Push switch (41).

Refer to steps (a) 1 through 3 to install push switch (41) and electrical contact (42).
  - (c) Push switch (39).

Refer to steps (a) 1 through 3 to install push switch (39) and electrical contact (37).
  - (d) Push switch (36).

Refer to steps (a) 1 through 3 to install push switch (36) and electrical contact (37).
- c. Position motor controller (34) on a clean flat surface.
- d. Circuit breaker. FIGURE 2-201 (Sheet 1).
  - (1) Position circuit breaker (1) over connector assembly (3) in motor controller.
  - (2) Engage circuit breaker on connector assembly.
  - (3) Secure circuit breaker to motor controller panel with mounting screws.
  - (4) Install switch cover over circuit breaker and secure cover with self locking screw (2).
  - (5) Connect electrical leads to circuit breaker (1). Remove tags.
- e. Terminal block (receptacle).
  - (1) Position terminal block (15) over mounting screw holes on motor controller panel.
  - (2) Install machine screws (18), lockwashers (17) and plain hex nuts (16) and secure terminal block to motor controller panel.
  - (3) Connect electrical leads to terminal block (15). Remove tags.
- f. Fuseholder block.



- (1) Position fuseholder blocks (8 and 9) over mounting screw holes on motor controller panel.
  - (2) Install machine screws (14), lockwashers (13) and plain hex nuts (12) and secure terminal block to motor controller panel.
  - (3) Connect electrical leads to fuseholder blocks. Remove tags.
  - (4) Install fuse cartridges (10 and 11).
- g. Transformer.
- (1) Position transformer (4) over mounting screw holes on motor controller panel.
  - (2) Install four machine screws (7), lockwashers (6) and plain hex nuts (5) and secure each terminal block to motor controller panel.
  - (3) Connect electrical leads to transformer. Remove tags.
- h. Auxiliary contact.
- (1) Position motor starter (19) on a clean flat surface.
  - (2) Attach auxiliary contact (23) to motor starter (19).
  - (3) Secure auxiliary contact with two attaching screws (22) to motor starter.
  - (4) Connect electrical leads to auxiliary contact.
  - (5) Repeat steps (2) through (4) to install auxiliary contact on opposite side of motor starter, if applicable.
- i. Thermal release relay.
- (1) Position thermal release relay (20) on motor starter with control circuit wire exposed.
  - (2) Connect control circuit wire to thermal release relay. Remove tag.
  - (3) Secure thermal release relay to motor starter base plate with three machine screws (21).
- j. Electrical contact assembly.
- (1) Compress and install push bar springs into spring slots on each armature lever relay push bar.
  - (2) Install armature lever relay push bars into magnet housing as noted during disassembly.
  - (3) Position electrical contact assembly (25) on armature lever relay push bars at rear of magnet housing.

- (4) Install four machine screws (26) and secure electrical contact assembly (26) to armature lever relay push bars.

k. Electrical contact kit.

- (1) Position magnet spring, magnet frame (29) and magnet strap into magnet housing.
- (2) Install two machine screws (27) and secure magnet spring and magnet frame (30) to magnet housing with magnet strap.
- (3) Install by plugging electrical coil (30) into socket on magnet housing of electrical contact kit (24).
- (4) Install by attaching armature spring plate (32) to slotted ends of each armature lever relay push bars.
- (5) Lower armature lever relay (31) into each slot on armature lever relay push bars as noted during disassembly. It may be necessary to depress armature spring plate (32) slightly to accommodate armature lever relay (31).
- (6) Position cover on electrical contact kit (24).
- (7) Install two machine screws (33) and secure cover.

l. Motor starter.

- (1) Position motor starter over mounting screw holes on motor controller panel.
- (2) Install three mounting screws and secure motor starter to panel.

m. Replace motor controller as specified in paragraph 2-222.

2-252. Repair/Replace Motor Control Center, Engine Room Vent.

This task covers: a. Removal, b. Replacement.

INITIAL SETUP

Tools

Tool kit, electrician's,  
5180-00-391-1087

Materials/Parts

Warning tags, Item 1, Appendix C

Equipment Condition

On ship service switchboard turned OFF  
ENG RM VENT MCC circuit breaker and  
tagged "Out of Service - Do Not  
Operate."

Following motor controllers removed as  
specified in paragraph 2-222.  
Engine Room Exhaust Fan  
Engine Room Supply Fan

REMOVAL

NOTE

Procedures required to make Engine Room Vent  
Motor Control Center ready for removal from  
vessel are basically the same as described  
in paragraph 2-232.

REPLACEMENT

NOTE

Procedures required to complete installation  
of Engine Room Vent Motor Control Center  
once placed into position in vessel are  
basically the same as those described in  
paragraph 2-232.

---

2-253. Replace Motor Control Center, Forward Deck Machinery. (FIGURE 2-202)

---

This task covers: a. Removal, b. Repair, c. Replacement.

---

### INITIAL SETUP

#### Tools

Tool kit, electrician's  
5180-00-391-1087

#### Equipment Condition

On ship service switchboard turn OFF  
FWD DECK MCHRY MCC circuit breaker  
and tag "Out of Service - Do Not  
Operate."

#### Materials/Parts

Refer to motor controller/controller  
being serviced.

Warning tags, Item 1, Appendix C

---

### REMOVAL

- a. Motor controller, Bow Windlass No. 1 and No. 2. Refer to paragraph 2-254.
- b. Motor controller, Bowthruster Steering Motor. Refer to paragraph 2-256.
- c. Controller, Bowthruster JACKET WATER HEATER. Refer to paragraph 2-258.
- d. Motor Control Center, Forward Deck Machinery. Refer to 2-260.

### REPAIR

Refer to replacement parts list of motor controller/controller being serviced.

### REPLACEMENT

- a. Motor Control Center, Forward Deck Machinery. Refer to paragraph 2-260.
- b. Controller, Bowthruster JACKET WATER HEATER. Refer to paragraph 2-258.
- c. Motor controller, Bowthruster Steering Motor. Refer to paragraph 2-256.
- d. Motor controller, Bow Windlass No. 1 and 2. Refer to paragraph 2-254.
- e. On ship service switchboard turn ON FWD DECK MCHRY MCC circuit breaker and remove tag.

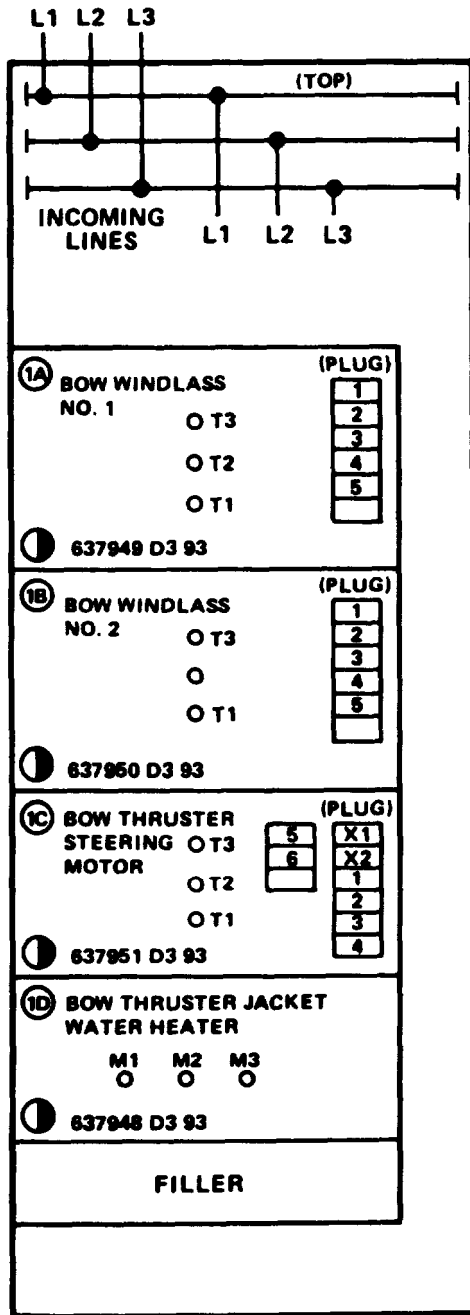


FIGURE 2-202. Motor Control Center. Forward Deck Machinery.

---

2-254. Replace Motor Controller, Bow Windlass 1 & 2. (FIGURE 2-203)

---

This task covers: a. Removal, b. Replacement.

---

### INITIAL SETUP

#### Tools

Tool kit, electrician's,  
5180-00-391-1087

#### Equipment Condition

On ship service switchboard turn OFF  
FWD DECK MCHRY MCC circuit breaker  
and tag "Out of Service - Do Not  
Operate."

#### Materials/Parts

Warning tags, Item 1, Appendix C

---

### REMOVAL

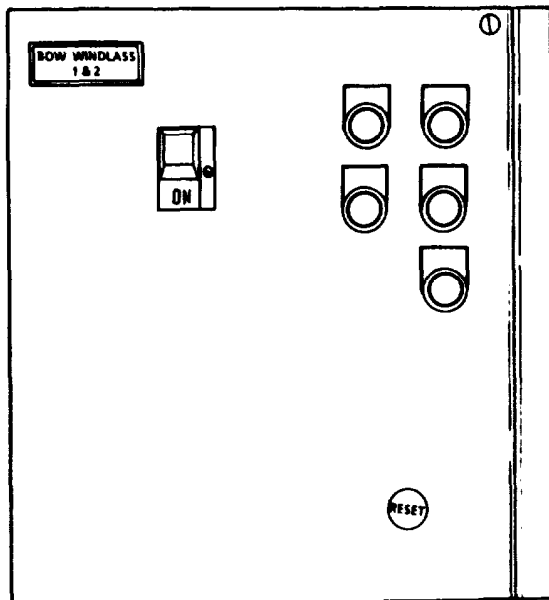
#### NOTE

Procedures for REMOVAL of the Bow Windlass 1 and 2 motor controller are basically the same as those described in paragraph 2-222 and illustrated in FIGURE 2-192. For configuration variance of the Engine Room Supply Fan refer to FIGURE 2-203.

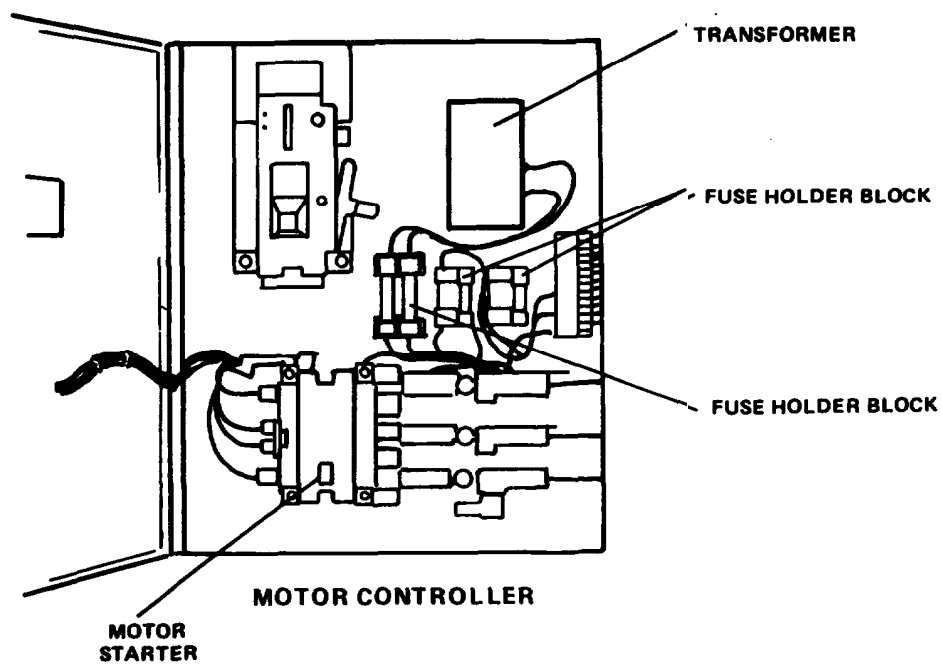
### REPLACEMENT

#### NOTE

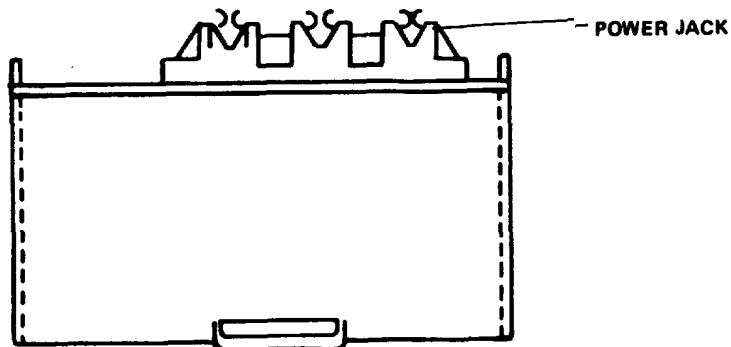
Procedures for REPLACEMENT of the Bow Windlass 1 and 2 motor controller are basically the same as those described in paragraph 2-222 and illustrated in FIGURE 2-192. For configuration variance of the Engine Room Supply Fan refer to FIGURE 2-203.



FRONT VIEW



MOTOR STARTER



TOP VIEW

FIGURE 2-203. Motor Controller, Bow Windlass 1 & 2.

---

2-255. Repair Motor Controller, Bow Windlass 1 & 2.

---

This task covers: a. Disassembly, b. Repair, c. Assembly.

---

### INITIAL SETUP

#### Tools

Tool kit, electrician's,  
5180-00-391-1087

#### Equipment Condition

Motor controller removed as specified  
in paragraph 2-222.

#### Materials/Parts

Motor starter P/N A10E-2  
Electrical contact kit P/N 6-35-2  
Lever armature P/N 48-1019  
Electrical coil P/N 9-1889-1  
Electrical contact assembly P/N C320RB1  
Auxiliary contact P/N C320KB2  
Electrical contact assembly P/N C320KA2  
Transformer P/N 42-3537-19  
Cartridge fuse P/N 44-2074-12,  
P/N 44-1687-16  
Circuit breaker P/N HMCP100RC3  
Incandescent lamp P/N 28-2202  
Electrical contact P/N 10250T51,  
P/N 10250T53  
Thermal heater P/N H1052  
Warning tags, Item 1, Appendix C

---

### DISASSEMBLY

#### **NOTE**

Refer to FIGURE 2-203, to compare  
differences in component arrangement, push  
switches, indicator lights, terminal blocks  
and fuse holder blocks used.

Refer to paragraph 2-222.

### REPAIR

Refer to replacement parts list.

### ASSEMBLY

Refer to paragraph 2-222.



---

**2-256. Replace Motor Controller, Bowthruster Steering Motor.**

---

This task covers: a. Removal, b. Replacement.

---

**INITIAL SETUP****Tools**

Tool Kit, Electrician's,  
5180-00-391-1087

**Materials/Parts**

Warning Tags, Item 1, Appendix C

---

**Equipment Condition**

On Ship Service Switchboard Turn OFF  
FWD DECK MCHRY MCC Circuit Breaker  
and Tag, "Out of Service - Do Not  
Operate."

**REMOVAL** FIGURE 2-192

Refer to paragraph 2-222.

**REPLACEMENT** FIGURE 2-192

Refer to paragraph 2-222.

**2-257. Repair Motor Controller, Bowthruster Steering Motor.**

---

This task covers: a. Disassembly, b. Repair, c. Assembly.

---

**INITIAL SETUP**

Tools

Tool Kit, Electrician's,  
5180-00-391-1087

Equipment Condition

Motor controller removed as specified  
in paragraph 2-222.

Materials/Parts

Motor Starter P/N A10C-1  
Electrical Contact Kit P/N 6-23-2  
Lever Armature P/N 48-1019  
Electrical Coil P/N 9-1887-7  
Electrical Contact Assembly P/N C320KB1  
P/N C320RA2  
Auxiliary Contact P/N C320RB2  
Cartridge Fuse P/N 44-1687-16  
Circuit Breaker P/N HMCP007C0  
Incandescent Lamp P/N 28-762  
Electrical Contact P/N 10250T51,  
P/N 10250T53  
Thermal Heater P/N H1042  
Warnings Tags, Item 1,  
Appendix C

---

**DISASSEMBLY**

Refer to paragraph 2-223.

**REPAIR**

Refer to replacement parts list.

**ASSEMBLY**

Refer to paragraph 2-223.

---

2-258. Replace Controller, Bowthruster Jacket Water Heater.

---

This task covers: a. Removal, b. Replacement.

---

INITIAL SETUP

Tools

Tool kit, electrician's,  
5180-00-391-1087

Materials/Parts

Warning tags, Item 1, Appendix C

---

Equipment Condition

On ship service switchboard turn OFF  
FWD DECK MCHRY MCC circuit breaker  
and tag "Out of Service - Do Not  
Operate."

REMOVAL

Refer to paragraph 2-224.

REPLACEMENT

Refer to paragraph 2-224.

2-259. Repair Controller, Bowthruster Jacket Water Heater.

---

This task covers: a. Disassembly, b. Repair, c. Assembly.

---

### INITIAL SETUP

#### Tools

Tool kit, electrician's  
5180-00-391-1087

#### Equipment Condition

Controller removed as specified  
in paragraph 2-224.

#### Materials/Parts

Circuit breaker P/N FS360015A  
Warning tags, Item 1, Appendix C

---

### DISASSEMBLY

Refer to paragraph 2-225.

### REPAIR

Repair to circuit breaker is by replacement.

### ASSEMBLE

Refer to paragraph 2-225.

---

2-260. Replace/Repair Motor Control Center, Forward Deck Machinery.

---

This task covers: a. Removal, b. Replacement.

---

INITIAL SETUP

Tools

Tool kit, electrician's,  
5180-00-391-1087

Materials/Parts

Warning tags, Item 1, Appendix C

Equipment Condition

On main switchboard turn OFF  
FWD DECK MCHRY MCC circuit breaker  
and "Out of Service - Do Not  
Operate."

Following motor controllers removed as  
specified in paragraphs 2-222 and 2-  
224.

Bow Windlass No. 1 and No. 2  
Bowthruster Steering Motor  
Bowthruster Jacket Water Heater

---

REMOVAL FIGURE 2-196

Refer to paragraph 2-232.

REPLACEMENT FIGURE 2-196

Refer to paragraph 2-232.

---

2-261. Replace Rotor Controller, Stem Windlass. (FIGURE 2-204)

---

This task covers: a. Removal, b. Replacement, c. Test.

---

### INITIAL SETUP

#### Tools

Tool kit, electrician's  
5180-00-391-1087

#### Equipment Condition

On ship service switchboard turn OFF  
STERN WINDLASS circuit breaker and  
tag "Out of Service - Do Not  
Operate."

#### Materials/Parts

Warning tags, Item 1, Appendix C

---

### REMOVAL

#### NOTE

Switch handle must be "OFF" to open door.

- a. Pull down switch handle (8) to "OFF."
- b. Loosen two Latch Screws (1) on motor controller door.
- c. Open door (2).
- d. Remove two plain hex nuts (9), lockwashers (10) and machine screws (11) from switch handle.
- e. Disengage switch handle from trip bar (7) on rotary switch (6).
- f. Remove switch handle assembly (12).
- g. Tag and disconnect electrical leads from push switches (13) on rear of front panel flange.
- h. Tag and disconnect electrical leads from transformer (3), rotary switch (6), terminal board (14) and motor starter (16) (external wiring).
- i. Remove (external wiring) through opening at top of enclosure.
- j. Remove three plain hex nuts (4) and flat washers (5) from mounting screws on enclosure.

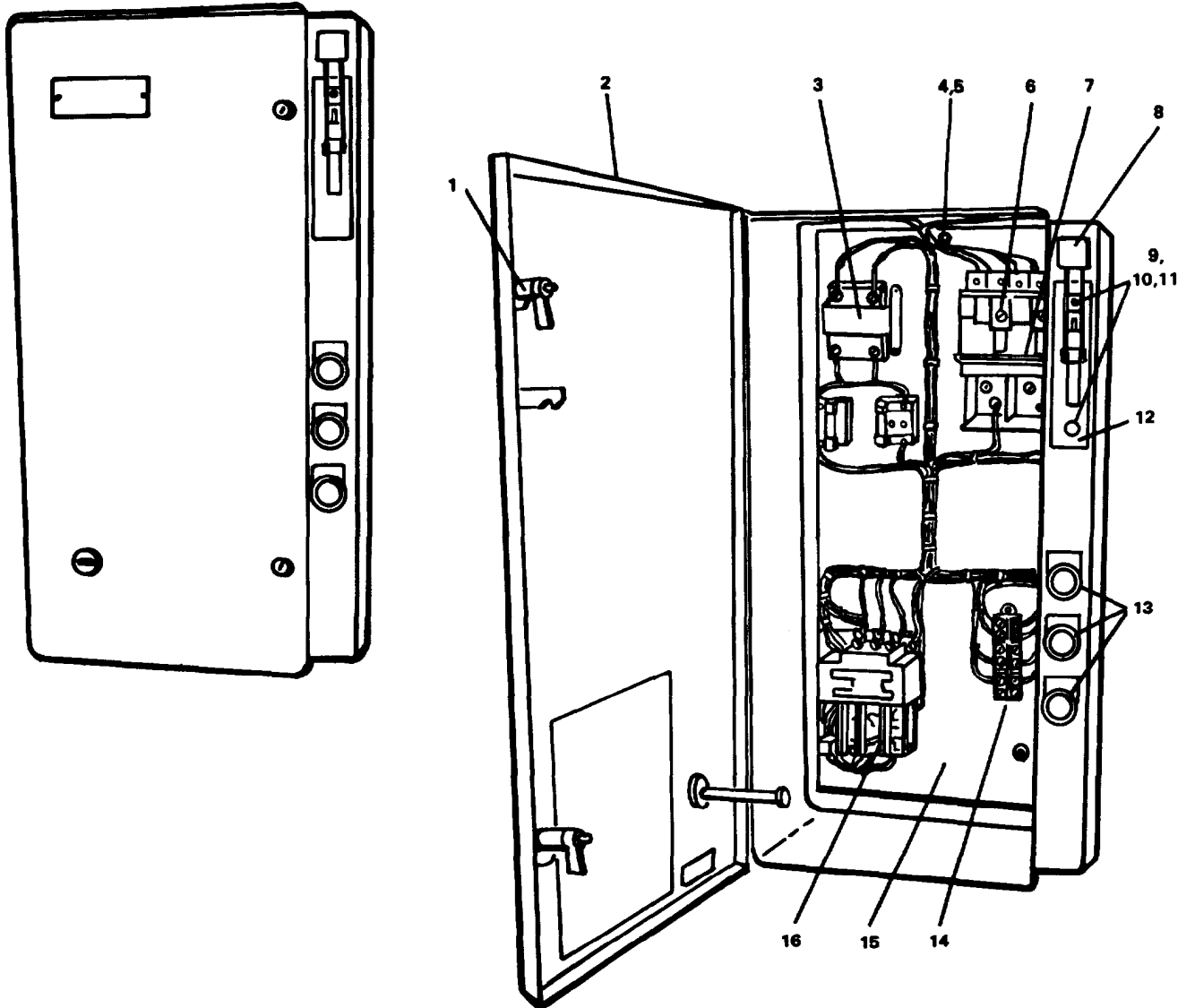


FIGURE 2-204. Motor Controller, Stern Windlass.

- h. Remove motor controller panel (15) from enclosure.

**REPLACEMENT**

- a. Position motor controller panel (15) over mounting screws on enclosure.
- b. Install three plain hex nuts (4) and flat washers (5) and secure motor controller panel to enclosure.
- c. Direct (external wiring) through opening at top of enclosure.
- d. Connect electrical leads to motor starter (16), terminal board (14), rotary switch (6) and transformer (3), (external wiring). Remove tags.
- f. Connect electrical leads to push switches (13) on rear of front panel flange.
- g. Position switch handle assembly (12) on front panel flange.
- h. Engage switch handle with trip bar (7) on rotary switch (6).
- i. Install two machine screws (11), lockwashers (10) and plain hex nuts (9) and secure switch handle assembly (12) to front panel flange.
- j. Close door (2).
- k. Secure door to motor controller with two latch screws (1).
- l. On ship service switchboard turn ON STERN WINDLASS circuit breaker and remove tag.

**TEST**

- a. Turn ON motor controller circuit breaker.
- b. Check motor controller operation. Refer to TM 55-1905-223-10.



---

**2-262. Repair Motor Controller, Stern Windlass. (FIGURE 2-205)**

---

This task covers: a. Disassembly, b. Repair, c. Assembly.

---

**INITIAL SETUP****Tools**

Tool Kit, Electrician's,  
5180-00-391-1087

**Equipment Condition**

Motor controller removed as specified  
in paragraph 2-190.

**Materials/Parts**

Motor Starter P/N A10FN0  
Electrical Contact Kit P/N 6-36-2  
Shunt Coil P/N 9-1891-1  
Electrical Contact Assembly P/N C320KA2  
Transformer P/N 44-2272  
Cartridge Fuse P/N 44-579  
Radio Frequency Coil P/N H1057  
Interlock Switch Base Mounted Auxiliary  
Contact C320KB7  
Warning Tags, Item 1, Appendix C

---

**DISASSEMBLY**

- a. Position motor controller (35) on a clean flat surface.
- b. Motor Starter.
  - (1) Tag and disconnect electrical leads from motor starter.
  - (2) Remove three mounting screws securing motor starter (22) to motor controller panel.
  - (3) Remove motor starter.
- c. Electrical contact kit.
  - (1) Position motor starter on a clean flat surface.
  - (2) Refer to paragraph 2-222 for removal. Note slight differences between armature and armature spring plates used.
  - (3) Remove helical compression springs from slotted ends on armature push bars.

- d. Interlock/Shunt coil/Electrical contact assembly.
  - (1) Refer to paragraph 2-223, removal of auxiliary contact.
  - (2) Remove interlock (26).
  - (3) Remove shunt coil (25).
  - (4) Remove electrical contact assembly (27).
- e. Overload coils.
  - (1) Refer to paragraph 2-222, removal of thermal release relay.
  - (2) Overload coils (23).
- f. Transformer.
  - (1) Tag and disconnect electrical leads from transformer (1). (Internal wiring.)
  - (2) Remove four plain hex nuts (2), lockwashers (3) and machine screws (4) transformer.
  - (3) Remove transformer.
- g. Fuseholder block.
  - (1) Tag and disconnect electrical leads from fuse blocks (28) and (33).
  - (2) Remove fuse cartridges (29) and (34).
  - (3) Remove two plain hex nuts (30), lockwashers (31) and machine screws (32) from each fuse block.
  - (4) Remove Fuse blocks.
- h. Terminal board.
  - (1) Tag and disconnect electrical leads from terminal board (9). (Internal wiring.)
  - (2) Remove two plain hex nuts (12), lockwashers (13) and machine screws (14) from section end (10).
  - (3) Remove terminal board and end section.
  - (4) Remove terminal board marker strip (11).
- i. Rotary switch.
  - (1) Tag and disconnect electrical leads from rotary switch (5). (Internal wiring.)

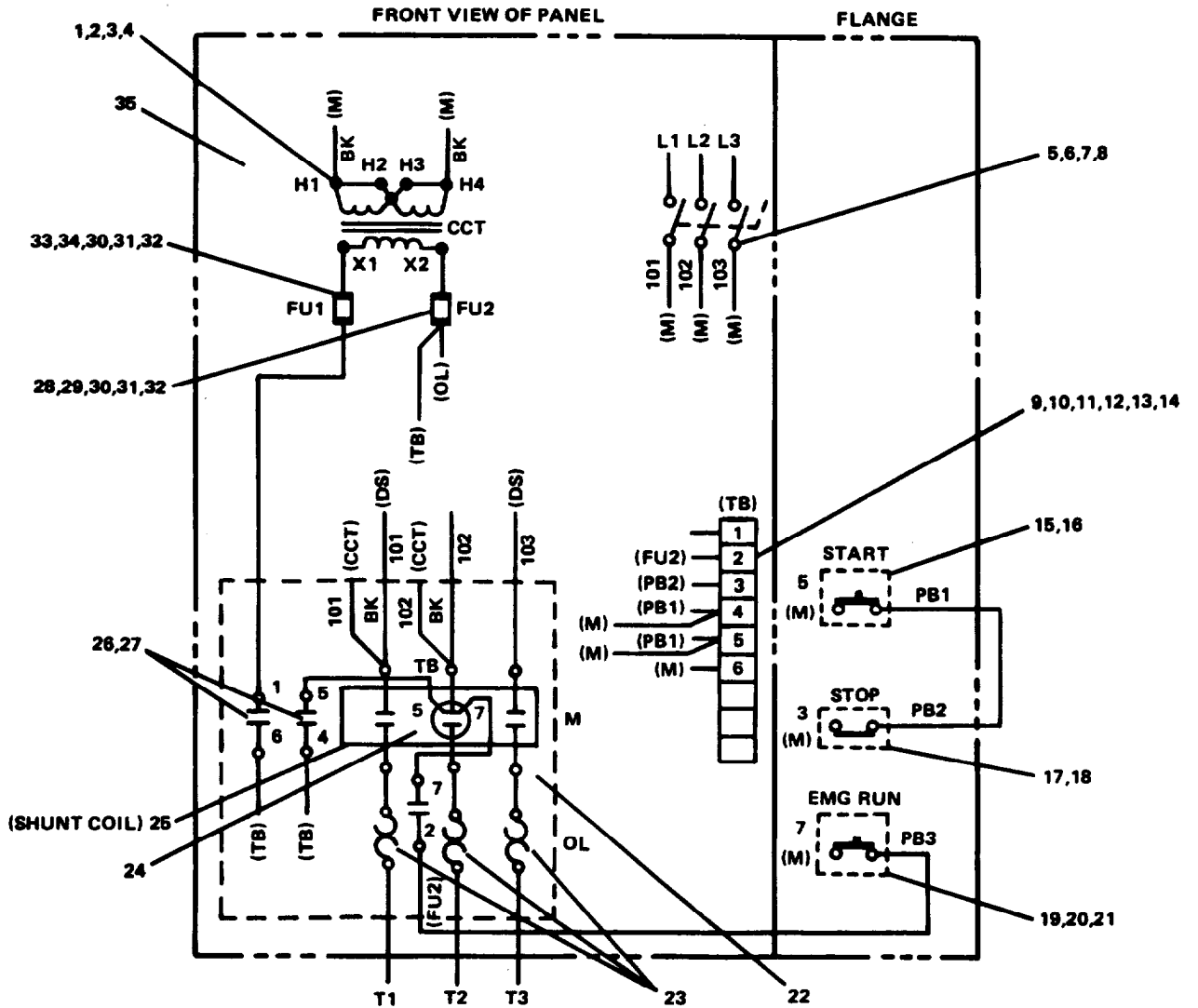


FIGURE 2-205. Motor Controller, Stern Windlass Repair.

## TM 55-1905-223-24-18-1

(2) Remove four plain hex nuts (6), lockwashers (7) and machine screws (8) from rotary switch.

(3) Remove rotary switch.

j. Push switches.

(1) Push switch (15).

(a) Unscrew lock nut (16) from push switch (15) at front panel flange.

(b) Remove push switch from rear of flange.

(2) Push switch (17).

Refer to steps (1)(a) and (b) to remove push switch (17) and lock nut (18).

(3) Push switch (19) and 20).

Refer to steps (1)(a) and (b) to remove push switch (19, 20) and lock nut (21).

### **REPAIR**

Repair of motor controller consists of replacing: Motor starter (22), electrical contact kit (24), interlock (26), shunt coil (25), electrical contact assembly (27), transformer (1), fuse cartridge (29), (34), radio frequency coil (23).

### **ASSEMBLY**

a. Push switches.

(1) Push switch (19, 20).

(a) Position push switch (19, 20) at rear of front panel flange.

(b) Install lock nut (21) on push switch.

(2) Push switch (17).

Refer to step (1)(a) and (b) to install push switch (17) and lock nut (18).

(3) Refer to step (1)(a) and (b) to install push switch (15) and lock nut (16).

b. Rotary switch.

(1) Position motor controller (35) on a clean flat surface.

(2) Position rotary switch (5) on motor controller with mounting screw holes aligned.

- (3) Install four machine screws (8), lockwashers (7) and plain hex nuts (6) and secure rotary switch to motor controller.
  - (4) Connect electrical leads to rotary switch. (Internal wiring). Remove tags.
- c. Terminal board.
- (1) Install terminal board marker strip (11) at designated location on motor controller panel.
  - (2) Position terminal board (9) and end section (10) over mounting screw holes on motor controller panel.
  - (3) Install two machine screws (14), lock washers (13) and plain hex nuts (12) and secure terminal board to motor control panel.
  - (4) Connect electrical leads to terminal board. (Internal wiring). Remove tags.
- d. Fuseholder block.
- (1) Position fuse blocks (28) and (33) over mounting screw holes on motor controller panel.
  - (2) Install two machine screws (32), lockwashers (31) and plain hex nuts (30) and secure each fuse block to motor controller panel.
  - (3) Connect electrical leads to fuse blocks. Remove tags.
- e. Position transformer (1) over mounting screw holes on motor controller panel.
- (2) Install four machine screws (4), lockwashers (3) and plain hex nuts (2) and secure transformer to motor controller panel.
  - (3) Connect electrical leads to transformer. (Internal wiring). Remove tags.
- f. Overload coils.
- (1) Position motor starter (22) on a clean flat surface.
  - (2) Refer to paragraph 2-222, to install thermal release relay.
  - (3) Overload coils (23).
- g. Interlock/shunt coil/electrical contact assembly.
- (1) Refer to paragraph 2-223, to install auxiliary contact.
  - (2) Install interlock (26).
  - (3) Install shunt coil (25).
  - (4) Install electrical contact assembly (27).

**TM 55-1905-223-24-18-1**

h. Electrical contact kit.

- (1) Refer to paragraph 2-223 for installation.
- (2) Install helical compression springs into slotted ends on armature push bars.

i. Motor starter.

- (1) Position motor starter (22) over mounting screw holes on motor controller panel.
- (2) Install three mounting screws and secure motor starter to motor controller panel.
- (3) Connect electrical leads to motor starter. Remove tags.

j. Replace motor controller as specified in paragraph 2-261.

---

2-263. Replace Motor Controller, Fire Pump 1 and 2.

---

This task covers: a. Removal, b. Replacement.

---

INITIAL SETUP

Tools

Tool kit, electrician's,  
5180-00-391-1087

Equipment Condition

On ship service switchboard turn OFF  
FIRE PUMP 1 and FIRE PUMP 2 circuit  
breakers and tag "Out of Service -  
Do Not Operate."

Materials/Parts

Warning tags, Item 1, Appendix C

---

REMOVAL

Refer to paragraph 2-261.

REPLACEMENT

Refer to paragraph 2-261.

2-264. REPAIR MOTOR CONTROLLER, FIRE PUMP 1 AND 2.

---

THIS TASK COVERS: A. DISASSEMBLY, B. REPAIR, C. ASSEMBLY.

---

**INITIAL SETUP**

**TOOLS**

TOOL KIT, ELECTRICIAN'S,  
5180-00-391-1087

**Equipment Condition**

MOTOR CONTROLLER REMOVED AS SPECIFIED  
IN PARAGRAPH 2-261.

**MATERIALS/PARTS**

MOTOR STARTER P/N A10EN0  
ELECTRICAL CONTACT KIT P/N 6-35-2  
ELECTRICAL COIL P/N 9-1889-1  
ELECTRICAL CONTACT ASSEMBLY P/N C320KB4  
TRANSFORMER P/N 44-2270  
CARTRIDGE FUSE P/N 44-576  
THERMAL HEATER P/N H1051  
ELECTRICAL CONTACT ASSEMBLY  
P/N C320KA1, P/N C320KA2  
INTERLOCK SWITCH P/N 95-691  
INDICATOR LIGHT P/N 10250T34G,  
P/N 10250T34W

---

**DISASSEMBLY**

REFER TO PARAGRAPH 2-262.

**REPAIR**

REFER TO REPLACEMENT PARTS LIST.

**ASSEMBLY**

REFER TO PARAGRAPH 2-262.



---

2-265. Replace Motor Controller, Steering Gear Hydraulic Pump.

---

This task covers: a. Removal, b. Replacement.

---

**INITIAL SETUP**

**Tools**

Tool kit, electrician's,  
5180-00-391-1087

**Materials/Parts**

Motor controller P/N 25628

**Equipment Condition**

On ship service switchboard turn OFF  
PORT STG GEAR circuit breaker and  
tag "Out of Service - Do Not  
Operate."

On emergency generator switchboard turn  
OFF STBD STEERING GEAR and tag "Out  
of Service - Do Not Operate."

---

**REMOVAL**

Refer to paragraph 2-261.

**REPLACEMENT**

Refer to paragraph 2-261.

---

2-266. Repair Motor Controller, Steering Gear Hydraulic Pump. (FIGURE 2-206)

---

This task covers: a. Disassembly, b. Repair, c. Assembly,

---

### INITIAL SETUP

#### Tools

Tool kit, electrician's,  
5180-00-391-1087

#### Equipment Condition

Motor controller removed as specified  
in paragraph 2-261.

#### Materials/Parts

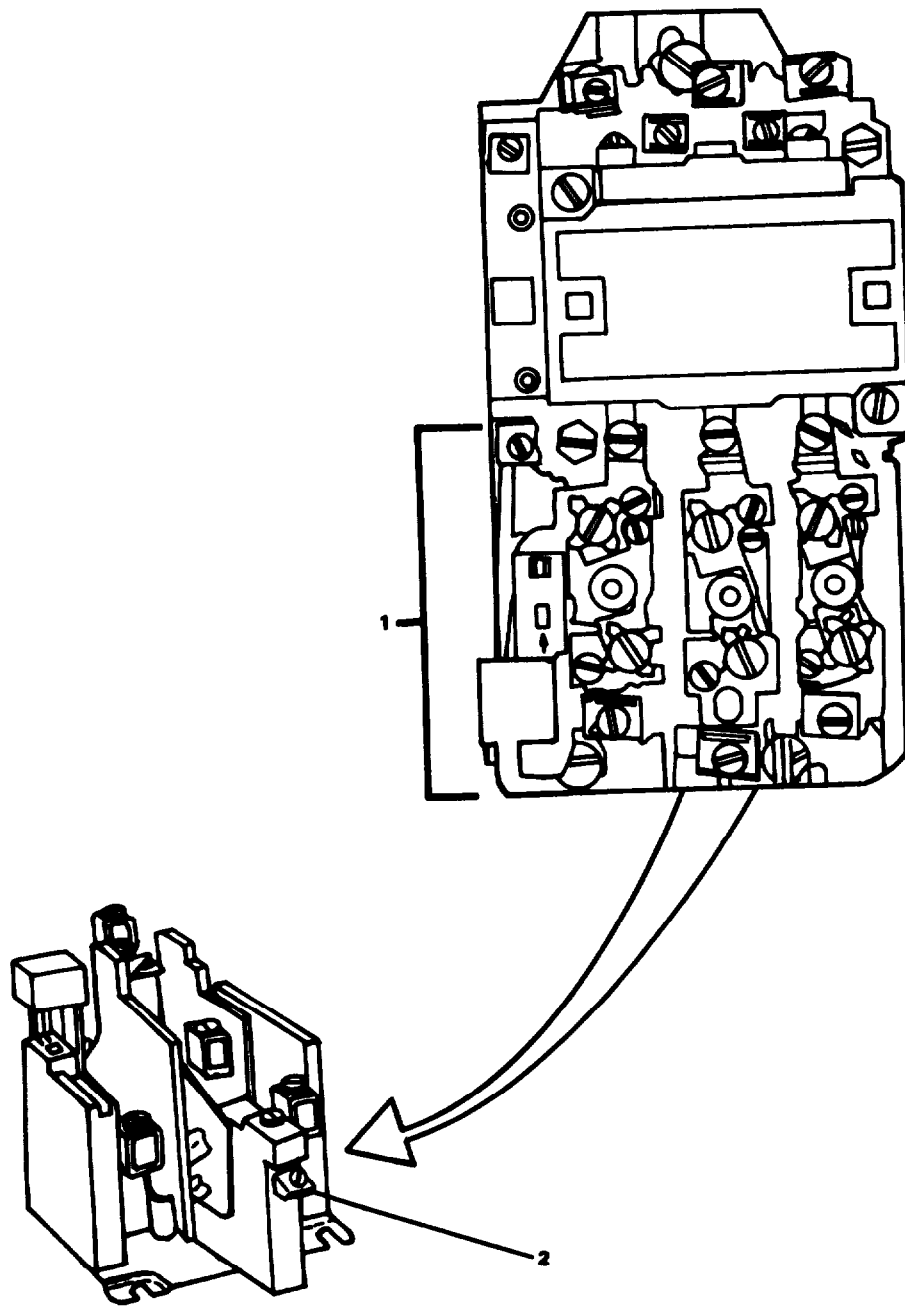
Motor starter P/N A10DN0  
Electrical contact kit P/N 6-34-2  
Electrical coil P/N 9-2526-1  
Electrical contact assembly P/N C320KB1  
Electrical contact assembly P/N  
C320KA1, P/N C320RA2  
Transformer P/N 10942H59  
Cartridge fuse P/N 44-2074-23  
Contact P/N C300KA1  
Interlock switch P/N 95-704-6  
Indicator light P/N 10250T34G,  
P/N 10250T34W  
Thermal heater P/N H1044  
Warning tags, Item 1, Appendix C

---

### DISASSEMBLY

Disassembly of motor controller components is the same as described in paragraph 2-262 with exception of component items shown in FIGURE 2-206.

- a. Tag and disconnect wiring to relay assembly (1, FIGURE 2-206).
- b. Remove associated hardware, circuit control wire, and relay unit (1).
- c. Remove contact (2).



**INSTALLING CONTACT  
ON RELAY ASSEMBLY**

FIGURE 2-206. Motor Controller, Steering Gear Hydropump,  
Auxiliary Contact Added.

**REPAIR**

Repair to motor controller unit is by replacement of parts as stated in paragraph 2-262 with the addition of auxiliary contact (2, FIGURE 2-206).

**ASSEMBLY**

Assembly of motor controller components is the same as described in paragraph 2-262 with the exception items shown in FIGURE 2-206.

- a. Install contact (2, FIGURE 2-206).
- b. Install relay assembly (1) with associated circuit control wire and associated hardware.

(1) Connect wiring to relay assembly and remove tags.

---

2-267. Replace Motor Controller, Fresh Water Pump 1 & 2.

---

This task covers: a. Removal, b. Replacement.

---

INITIAL SETUP

Tools

Tool kit, electrician's,  
5180-00-391-1087

Equipment Condition

On ship service switchboard turn  
OFF FW PUMP 1 and FW PUMP 2  
circuit breakers and tag  
"Out of Service - Do Not Operate."

Materials/Parts

Warning tags, Item 1, Appendix C

---

REMOVAL

Refer to paragraph 2-261.

REPLACEMENT

Refer to paragraph 2-261.

2-268. Repair Motor Controller, Fresh Water Pump 1 & 2.

---

This task covers: a. Disassembly, b. Repair, c. Assembly.

---

### INITIAL SETUP

#### Tools

Tool kit, electrician's,  
5180-00-391-1087

#### Equipment Condition

Motor controller removed as specified  
in paragraph 2-261.

#### Materials/Parts

Motor starter P/N A10CNO  
Electrical contact kit P/N 6-23-2  
Electrical coil P/N 9-1887-1  
Electrical contact assembly P/N C320KB1  
Electrical contact assembly  
P/N C320KA2, P/N C320KA1  
Transformer P/N 44-2268  
Cartridge fuse P/N 44-574  
Thermal heater P/N H1037  
Interlock switch P/N 95-704-2  
Indicator light P/N 102501346,  
P/N 10250T34W

---

### DISASSEMBLY

Refer to paragraph 2-262.

### REPAIR

Refer to replacement parts list.

### ASSEMBLY

Refer to paragraph 2-262.

---

2-269. Replace Motor Controller, Bilge and Ballast Pump.

---

This task covers: a. Removal, b. Replacement.

---

INITIAL SETUP

Tools

Tool kit, electrician's,  
5180-00-391-1087

Equipment Condition

On ship service switchboard turn OFF  
BILGE PUMP circuit breaker and tag  
Out of Service - Do Not Operate."

Materials/Parts

---

REMOVAL

Refer to paragraph 2-261.

REPLACEMENT

Refer to paragraph 2-261.

2-270. Repair Motor Controller, Bilge and Ballast Pump.

---

This task covers: a. Disassembly, b. Repair, c. Assembly.

---

### INITIAL SETUP

#### Tools

Tool kit, electrician's,  
5180-00-391-1087

#### Equipment Condition

Motor controller removed as specified  
in paragraph 2-261.

#### Materials/Parts

Motor starter P/N A10FN0  
Electrical contact kit P/N 6-36-2  
Electrical coil P/N 9-1891-1  
Electrical contact assembly  
P/N C320KA2, P/N C320KA1  
Transformer P/N 44-2272  
Cartridge fuse P/N 44-579  
Radio frequency coil P/N H1057  
Indicator light P/N 10250T34G,  
P/N 10250T34W

---

### DISASSEMBLY

Refer to paragraph 2-262.

### REPAIR

Refer to replacement parts list.

### ASSEMBLY

Refer to paragraph 2-262.



---

2-271. Replace Motor Controller, Fuel Oil Transfer Pump No. 2.

---

This task covers: a. Removal, b. Replacement.

---

INITIAL SETUP

Tools

Tool kit, electrician's,  
5180-00-391-1087

Materials/Parts

Equipment Condition

On emergency generators switchboard  
turn OFF F.O. TRANSFER PUMP #2  
circuit breaker and tag "Out  
of Service - Do Not Operate."

---

REMOVAL

Refer to paragraph 2-261.

REPLACEMENT

Refer to paragraph 2-261.

2-272. Repair Motor Controller, Fuel Oil Transfer Pump No. 2

---

This task covers: a. Disassembly, b. Repair, c. Assembly.

---

INITIAL SETUP

Tools

Tool kit, electrician's,  
5180-00-391-1087

Equipment Condition

Motor controller removed as specified  
in paragraph 2-261.

Materials/Parts

Motor starter P/N A10CN0  
Electrical contact kit P/N 6-23-2  
Electrical coil P/N 9-1887-1  
Electrical contact assembly P/N 320KB1  
Electrical contact assembly P/N 320KA2,  
P/N 320KA1  
Transformer P/N 44-2268  
Cartridge fuse P/N 44-574  
Thermal heater, P/N H1026  
Interlock switch P/N 95-704-2  
Indicator light 10250T34G.  
P/N 10250T34W

---

DISASSEMBLY

Refer to paragraph 2-262.

REPAIR

Refer to replacement parts list.

ASSEMBLY

Refer to paragraph 2-262.

---

2-273. Replace Motor Controller, Galley Exhaust Fan.

---

This task covers: a. Removal, b. Replacement.

---

INITIAL SETUP

Tools

Tool kit, electrician's  
5180-00-391-1087

Equipment Condition

On power panel P211 turn OFF GALLEY EXH  
circuit breaker and tag "Out of  
Service - Do Not Operate."

Materials/Parts

Warning tags, Item 1, Appendix C

---

REMOVAL

Refer to paragraph 2-261.

REPLACEMENT

Refer to paragraph 2-261.

2-274. Repair Motor Controller, Galley Exhaust Fan.

---

This task covers: a. Disassembly, b. Repair, c. Assembly.

---

**INITIAL SETUP**

**Tools**

Tool kit, electrician's,  
5180-00-391-1087

**Equipment Condition**

Motor controller removed as specified  
in paragraph 2-261.

**Materials/Parts**

Motor starter P/N A10CN0  
Electrical contact kit P/N 6-23-2  
Electrical coil P/N 9-1887-1  
Electrical contact assembly P/N 3201KB1  
Electrical contact assembly P/N 320KA1,  
P/N 320KA2  
Transformer P/N 44-2268  
Cartridge fuse P/N 44-574  
Thermal heater P/N H1021  
Interlock switch P/N 95-704-2  
Indicator light P/N 10250T34G,  
P/N 10250T34W

---

**DISASSEMBLY**

Refer to paragraph 2-262.

**REPAIR**

Refer to replacement parts list.

**ASSEMBLY**

Refer to paragraph 2-262.

---

2-275. Replace Motor Controller, Lavatory Exhaust Fan.

---

This task covers: a. Removal, b. Replacement.

---

INITIAL SETUP

Tools

Tool kit, electrician's,  
5180-00-391-1087

Equipment Condition

On power panel P211 turn OFF TOILET EXH  
circuit breaker and tag "Out of  
Service - Do Not Operate."

Materials/Parts

Warning tags, Item 1, Appendix C

---

REMOVAL

Refer to paragraph 2-261.

REPLACEMENT

Refer to paragraph 2-261.

---

2-276. Repair Motor Controller, Lavatory Exhaust Fan.

---

This task covers: a. Disassembly, b. Repair, c. Assembly.

---

**INITIAL SETUP**

**Tools**

Tool kit, electrician's,  
5180-00-391-1087

**Equipment Condition**

Motor controller removed as specified  
in paragraph 2-261,

**Materials/Parts**

Motor starter P/N A10CN0  
Electrical contact kit P/N 6-23-2  
Electrical coil P/N 9-1887-1  
Electrical contact assembly P/N C320KB1  
Electrical contact assembly  
P/N C320KA1, P/N C320KA2  
Transformer P/N 44-2268  
Cartridge fuse P/N 44-574  
Thermal protector P/N H1117  
Interlock switch P/N 95-704-2  
Indicator light P/N 10250T34G,  
P/N 10250T34W

---

**DISASSEMBLY**

Refer to paragraph 2-262.

**REPAIR**

Refer to replacement parts list.

**ASSEMBLY**

Refer to paragraph 2-262.

---

2-277. Replace Motor Controller, Steering Gear Exhaust Fan.

---

This task covers: a. Removal, b. Replacement.

---

INITIAL SETUP

Tools

Tool kit, electrician's,  
5180-00-391-1083

Equipment Condition

On power panel P211 turn OFF STEERING  
GR EXH circuit breaker and tag "Out  
of Service - Do Not Operate."

Materials/Parts

Motor controller P/N 256287

---

REMOVAL

Refer to paragraph 2-261.

REPLACEMENT

Refer to paragraph 2-261.

---

2-278. Repair Motor Controller, Steering Gear Exhaust Fan.

---

This task covers: a. Disassembly, b. Repair, c. Assembly.

---

### INITIAL SETUP

#### Tools

Tool kit, electrician's,  
5180-00-391-1087

#### Equipment Condition

Motor controller removed as specified  
in paragraph 2-261.

#### MaterialS/Parts

Motor starter P/N A10CN0  
Electrical contact kit P/N 6-23-2  
Electrical coil P/N 9-1887-1  
Electrical contact assembly  
P/N C320KB1, C320KA1, C320KA2  
Transformer P/N 44-2268  
Cartridge fuse P/N 44-574  
Thermal protector P/N H1117  
Interlock switch P/N 95-704-2  
Indicator light P/N 10250T34G,  
P/N 10250T34W

---

### DISASSEMBLY

Refer to paragraph 2-262.

### REPAIR

Refer to replacement parts list.

### ASSEMBLY

Refer to paragraph 2-262.



---

2-279. Replace Motor Controller, Tunnel Supply Fan.

---

This task covers: a. Removal, b. Replacement.

---

INITIAL SETUP

Tools

Tool kit, electrician's,  
5180-00-391-1087

Equipment Condition

On power panel P211 turn OFF TUNNEL  
SUPPLY circuit breaker and tag  
"Out of Service - Do Not Operate."

Materials/Parts

Warning tags, Item 1, Appendix C

---

REMOVAL

Refer to paragraph 2-261.

REPLACEMENT

Refer to paragraph 2-261.

2-280. Repair Motor Controller, Tunnel Supply Fan.

---

This task covers: a. Disassembly, b. Repair, c. Assembly.

---

INITIAL SETUP

Tools

Tool kit, electrician's,  
5180-00-391-1087

Equipment Condition

Motor controller removed as specified  
in paragraph 2-261.

Materials/Parts

Motor starter P/N A10CN0  
Electrical contact kit P/N 6-23-2  
Electrical coil P/N 9-1887-1  
Electrical contact assembly  
P/N C320KB1, C320KA1, C320KA2  
Transformer P/N 44-2268  
Cartridge fuse P/N 44-574  
Thermal heater P/N H1024  
Interlock switch P/N 95-704-2  
Indicator light P/N 10250T34G,  
P/N 10250T34W

---

DISASSEMBLY

Refer to paragraph 2-262.

REPAIR

Refer to replacement parts list.

ASSEMBLY

Refer to paragraph 2-262.

---

2-281. Replace Motor Controller, Bowthruster Supply Fan.

---

This task covers: a. Removal, b. Replacement.

---

INITIAL SETUP

Tools

Tool kit, electrician's,  
5180-00-391-1087

Materials/Parts

Warning tags, Item 1, Appendix C

---

Equipment Condition

On power panel P211 turn off  
BOWTHRUSTER SUPPLY circuit breaker  
and tag "OUT of SERVICE - Do Not  
Operate."

REMOVAL

Refer to paragraph 2-261.

REPLACEMENT

Refer to paragraph 2-261.

2-282. Repair Motor Controller, Bowthruster Supply Fan.

---

This task covers: a. Disassembly, b. Repair, c. Assembly.

---

### INITIAL SETUP

#### Tools

Tool kit, electrician's,  
5180-00-391-1087

#### Equipment Condition

Motor controller removed as specified  
in paragraph 2-261.

#### Materials/Parts

Motor starter P/N A10CN0  
Electrical contact kit P/N 6-23-2  
Electrical coil P/N 9-1887-1  
Electrical contact assembly  
P/N C320KB1, C320KA1, C320KA2  
Transformer P/M 44-2268  
Cartridge fuse P/N 44-574  
Thermal heater P/N H1035  
Interlock switch P/N 95-704-2  
Indicator light P/N 10250T34G,  
P/N 10250T34W

---

### DISASSEMBLY

Refer to paragraph 2-262.

### REPAIR

Refer to replacement parts list.

### ASSEMBLY

Refer to paragraph 2-262.

---

2-283. Replace Motor Controller, Emergency Generator Room Supply Fan.

---

This task covers: a. Removal, b. Replacement.

---

**INITIAL SETUP**

Tools

Tool kit, electrician's,  
5180-00-391-1087

Equipment Condition

On power panel P211 turn OFF EMERG GEN  
RM SUPPLY circuit breaker and tag  
"Out of Service - Do Not Operate."

Materials/Parts

Warning tags, Item 1, Appendix C

---

**REMOVAL**

Refer to paragraph 2-261.

**REPLACEMENT**

Refer to paragraph 2-261.

2-284. Repair Motor Controller, Emergency Generator Room Supply Fan.

---

This task covers: a. Disassembly, b. Repair, c. Assembly.

---

INITIAL SETUP

Tools

Tool kit, electrician's,  
5180-00-391-1087

Equipment Condition

Motor controller removed as specified  
in paragraph 2-261.

Materials/Parts

Motor starter P/N A10CN0  
Electrical contact kit P/N 6-23-2  
Electrical coil P/N 9-1887-1  
Electrical contact assembly  
P/N C320KB1, C320KA1, C320KA2  
Transformer P/N 44-2268  
Cartridge fuse P/N 44-574  
Thermal protector P/N H1117  
Interlock switch P/N 95-704-2  
Indicator light P/N 10250T34G,  
P/N 10250T34W

---

**DISASSEMBLY**

Refer to paragraph 2-262.

**REPAIR**

Refer to replacement parts list.

**ASSEMBLY**

Refer to paragraph 2-262.

---

2-285. Replace Motor Controller, Galley Makeup Supply Fan.

---

This task covers: a. Removal, b. Replacement.

---

**INITIAL SETUP**

**Tools**

Tool kit, electrician's,  
5180-00-391-1087

**Equipment Condition**

On power panel P211 turn OFF GALLEY  
MAKEUP SUPPLY circuit breaker and tag  
"Out of Service - Do Not Operate."

**Materials/Parts**

Warning tags, Item 1, Appendix C

---

**REMOVAL**

Refer to paragraph 2-261.

**REPLACEMENT**

Refer to paragraph 2-261.

2-286. Repair Rotor Controller, Galley Makeup Supply Fan.

---

This task covers: a. Disassembly, b. Repair, c. Assembly.

---

### INITIAL SETUP

#### Tools

Tool kit, electrician's,  
5180-00-391-1087

#### Equipment Condition

Motor controller removed as specified  
in paragraph 2-162.

#### Materials/Parts

Motor starter P/N A10CN0  
Electrical contact kit P/N 6-23-2  
Electrical coil P/N 9-1887-1  
Electrical contact assembly  
P/N C320KB1, C320KA1, C320KA2  
Transformer P/N 44-2268  
Cartridge fuse P/N 44-574  
Thermal heater P/N H1021  
Interlock switch P/N 95-704-2  
Indicator light P/N 10250T34G,  
P/N 10250T34W

---

### DISASSEMBLY

Refer to paragraph 2-262.

### REPAIR

Refer to replacement parts list.

### ASSEMBLY

Refer to paragraph 2-262.



---

2-287. Replace Motor Controller, Galley Vent Hood Fan.

---

This task covers: a. Removal, b. Replacement.

---

INITIAL SETUP

Tools

Tool kit, electrician's,  
5180-00-391-1087

Materials/Parts

Warning tags, Item 1, Appendix C

Equipment Condition

On power panel P106 turn OFF GAYLORD HOOD circuit breaker; on power panel P211 turn OFF GALLEY EXH circuit breaker and tag "Out of Service - Do Not Operate."

---

REMOVAL

Refer to paragraph 2-261.

REPLACEMENT

Refer to paragraph 2-261.

2-288. Repair Motor Controller, Galley Vent Hood Fan.

---

This task covers: a. Disassembly, b. Repair, c. Assembly.

---

### INITIAL SETUP

#### Tools

Tool kit, electrician's,  
5180-00-391-1087

#### Equipment Condition

Motor controller removed as specified  
in paragraph 2-261.

#### Materials/Parts

Motor starter P/N A10CN0  
Electrical contact kit P/N 6-23-2  
Electrical coil P/N 9-1887-1  
Electrical contact assembly  
P/N C320KB1, C320KA1, C320KA2  
Transformer P/N 44-2268  
Cartridge fuse P/N 44-574  
Thermal heater P/N H1029  
Interlock switch P/N 95-704-2  
Indicator light P/N 10250T34G,  
P/N 10250T34W

---

### DISASSEMBLY

Refer to paragraph 2-262.

### REPAIR

Refer to replacement parts list.

### ASSEMBLY

Refer to paragraph 2-262.

---

2-289. Replace Motor Controller, Galley Duct Heater.

---

This task covers: a. Removal, b. Replacement.

---

INITIAL SETUP

Tools

Tool kit, electrician's,  
5180-00-391-1087

Materials/Parts

Warning tags, Item 1, Appendix C

---

Equipment Condition

On power panel P211 turn OFF GALLEY  
DUCT PRE-HTR circuit breaker and tag  
"Out of Service - Do Not Operate."

REMOVAL

Refer to paragraph 2-261.

REPLACEMENT

Refer to paragraph 2-261.

2-290. Repair Motor Controller, Galley Duct Heater.

---

This task covers: a. Disassembly, b. Repair, c. Assembly.

---

### INITIAL SETUP

#### Tools

Tool kit, electrician's,  
5180-00-391-1087

#### Equipment Condition

Motor controller removed as specified  
in paragraph 2-261.

#### Materials/Parts

Motor starter P/N C10EN0  
Electrical contact kit P/N 6-35-2  
Electrical coil P/N 9-1887-1  
Electrical contact assembly  
P/N C320KB4, C320KA1  
Transformer P/N 44-2270  
Cartridge fuse P/N 44-576  
Interlock switch P/N 95-691  
Indicator light P/N 10250T34G

---

### DISASSEMBLY

Refer to paragraph 2-262.

### REPAIR

Refer to replacement parts list.

### ASSEMBLY

Refer to paragraph 2-262.

---

2-291. Repair Ship Service Switchboard Circuit Breakers. (FIGURE 2-207)

---

This task covers: a. Removal, b. Repair, c. Replacement, d. Test.

---

### INITIAL SETUP

#### Tools

Tool kit, electrician's,  
5180-00-391-1087

#### Equipment Condition

Power to ship service switchboard OFF,  
locked out, and tagged "Out of  
Service - Do Not Operate".  
All switchboard circuit breakers OFF.

#### Materials/Parts

##### Circuit breaker

P/N THED136100 (2)  
P/N THED136015 (3)  
P/N THED136030 (3)  
P/N THED136090 with under voltage  
release, P/N TEDUV1-RS  
P/N THED136090 (2)  
P/N THED136080  
P/N THED136-35  
P/N TEC36050 with auxiliary switch,  
P/N TEDAS2B1-RS and circuit  
limiter, P/N TECLC36050  
P/N TFJ236125 (2)  
P/N TFJ236150 (4)  
P/N TFJ236125 with under voltage  
release P/N TFKUVA1-RS  
P/N TFJ236175 (3)  
P/N TJJ436300  
P/N TJJ436230 (2)

Warning tag, Item 1, Appendix C

---

### WARNING

**Electrocution, serious injury, or equipment damage can result from contact with live electrical circuits. Before beginning work on electrical systems, ensure electrical power is OFF, locked out and tagged to prevent turn on during maintenance.**

**REMOVAL**

- a. Turn door panel screws (2, FIGURE 2-207) counterclockwise to loosen.
- b. Remove door panel (8) using handrail (5). Store door panel (8) in safe out-of-way place.

**NOTE**

Circuit breaker may have internally mounted and factory installed accessories.

- c. Loosen associated screws from circuit breakers (1, 3, 4, 6 and 7).
- d. Remove circuit breakers by pulling straight out from their respective mountings.

**REPAIR**

Repair is by replacement of circuit breakers (1, 3, 4, 6, and 7).

**REPLACEMENT**

- a. Install circuit breakers (1, 3, 4, 6, and 7) by pushing straight into their respective mountings.
- b. Tighten associated screws to each circuit breaker.
- c. Install door panel (8).
- d. Turn door panel screws (2) clockwise until tight.
- e. Turn on power to ship service switchboard and remove tags.
- f. Turn ON circuit breakers (1, 3, 4, 6 and 7).

**TEST**

- a. Set 240V GROUND DETECTION SWITCH (13, FIGURE 2-215, Sheet 2 of 2) to TEST position.
- b. Three 240 GROUND DETECTION LIGHTS (6, FIGURE 2-215, Sheet 1 of 2) remain lit.

**NOTE**

If an indicator dims or goes out it indicates a ground fault condition.

- c. Set 240V GROUND DETECTION SWITCH (13) to NORM.

- d. Set 120V GROUND DETECTION SWITCH (9, FIGURE 2-215, Sheet 2 of 2) to TEST position.
- e. Three 120V GROUND DETECTION LIGHTS (6, FIGURE 2-215, Sheet 1 of 2) remain lit.

**NOTE**

If an indicator dims or goes out it indicates a ground fault condition.

- f. Set 120V GROUND DETECTION SWITCH (9) to NORM position.
- g. Set EMER 120V LIGHTING GROUND DETECTION SWITCH (15, FIGURE 2-211) to TEST position.
- h. Three EMER 120V LIGHTING GND DET (A, B, C) lights remain lit.

**NOTE**

If an indicator dims or goes out it indicates a ground fault condition.

- i. Set EMER 120V LIGHTING GROUND DETECTION SWITCH (15) to NORM position.

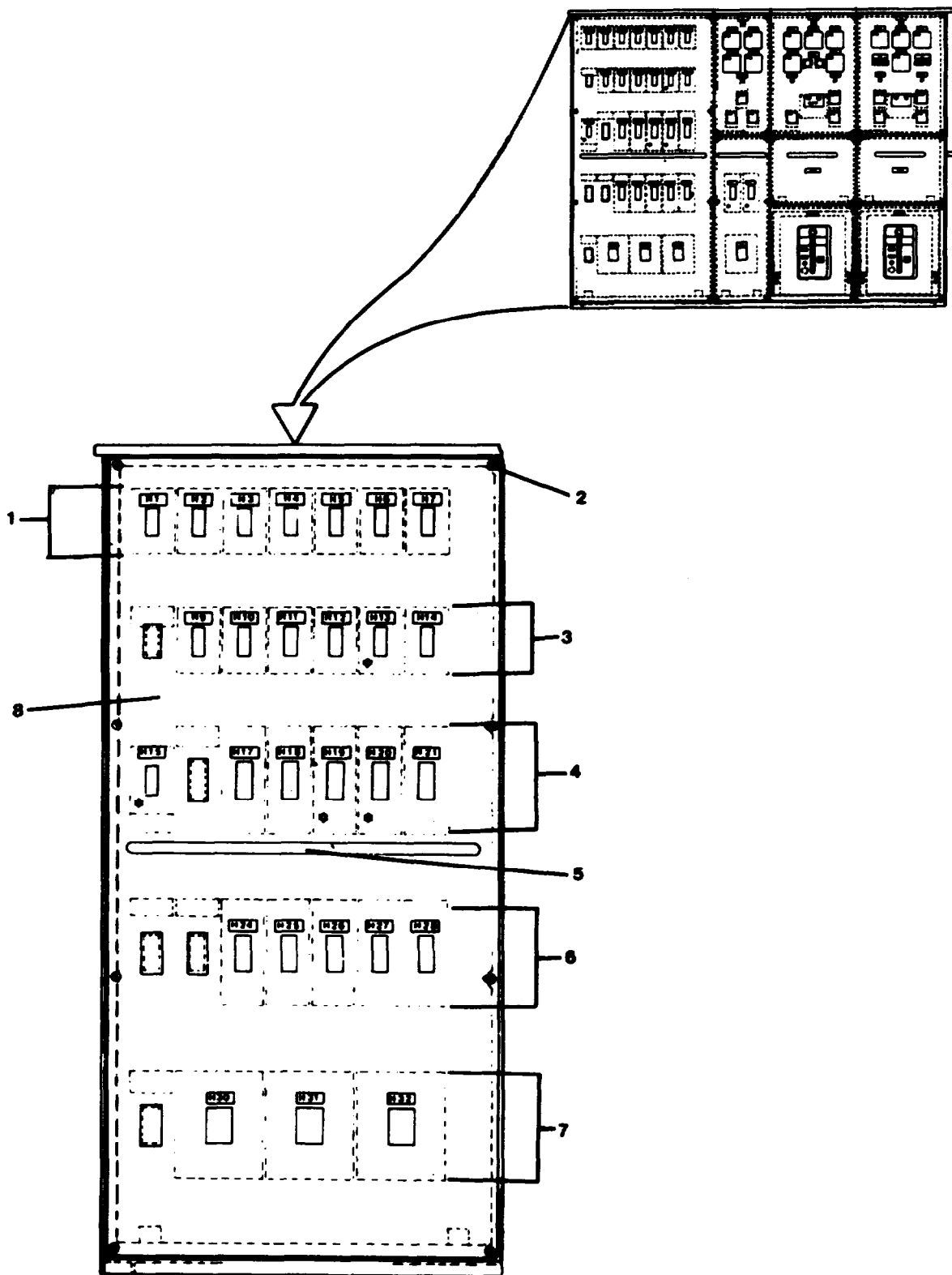


FIGURE 2-207. Ship Service Switchboard Left Hand Panel.



---

2-292. Repair Ship Service Switchboard Indicators, Meters, Switches, and Circuit Breaker.

---

This task covers: a. Disassembly, b. Repair, c. Assembly, d. Test.

---

### INITIAL SETUP

#### Tools

Tool kit, electrician's,  
5180-00-391-1087

#### Equipment Condition

Power to ship service switchboard OFF,  
locked out, and tagged "Out of  
Service - Do Not Operate".  
All switchboard circuit breakers OFF.

#### Material/Parts

Incandescent lamp, P/N 686-6-120 (2)  
Light lens P/N 80-0534-300 (2)  
Ammeter P/N 50-103131LSRS  
Frequency meter P/N 50-103372ANAN  
Rotary switch P/N 16SB1CA20  
Rotary switch P/N 16SB13P4T  
Wattmeter P/N 50-103221ARBU7CCA  
Voltmeter P/N 50-103021PZSJ  
Circuit breaker P/N TFJ236225 (2)  
Warning tags, Item 1, Appendix C

---

### WARNING

Electrocution, serious injury, or equipment damage can result from contact with live electrical circuits. Before beginning work on electrical systems, ensure electrical power is OFF, locked out and tagged to prevent turn on during maintenance.

### DISASSEMBLY

- a. Unscrew each light lens (1, 5, FIGURE 2-208) collar from its respective socket.
- b. Remove incandescent lamp from each socket.

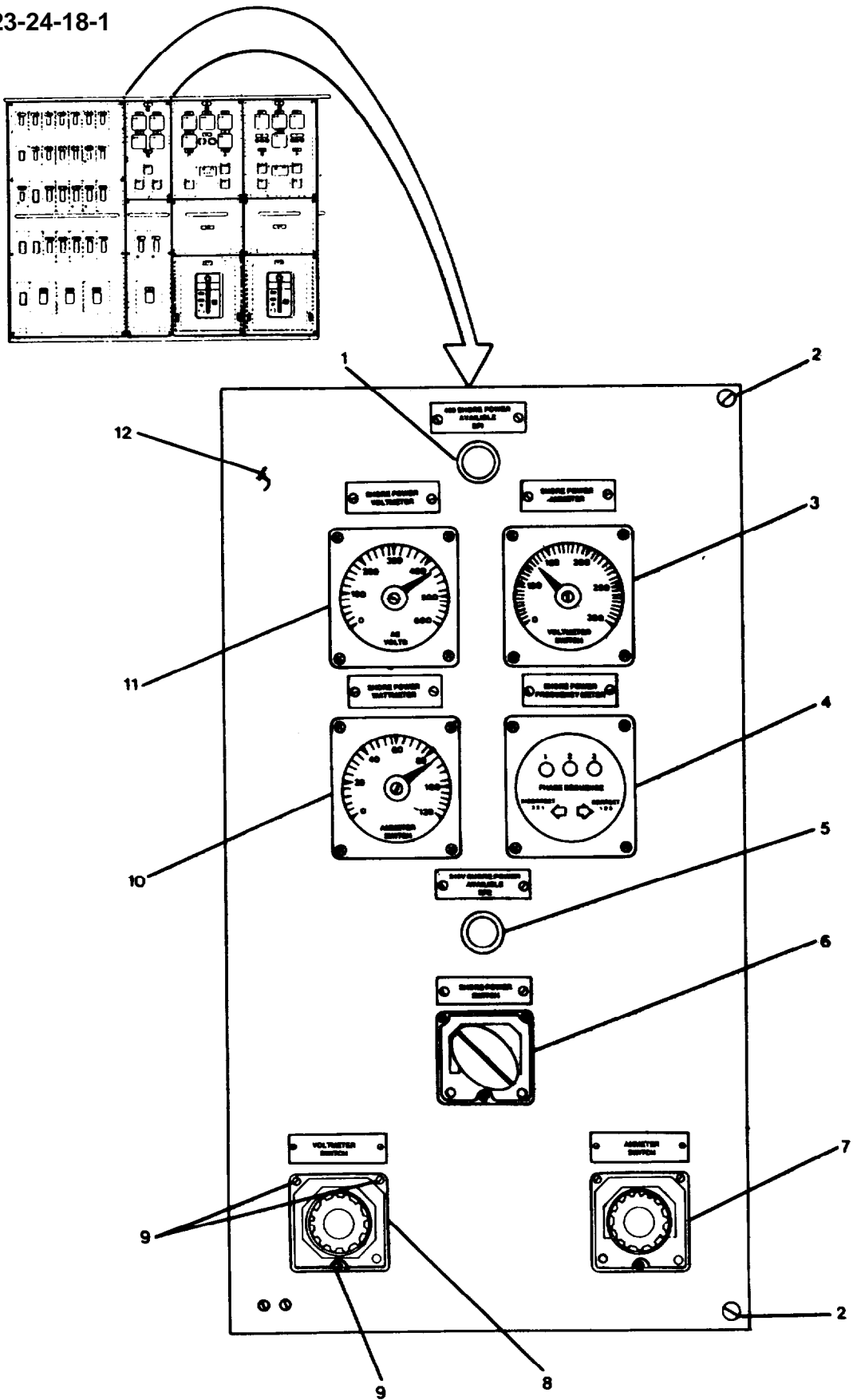


FIGURE 2-208. Ship Service Switchboard Top Left Center Panel.

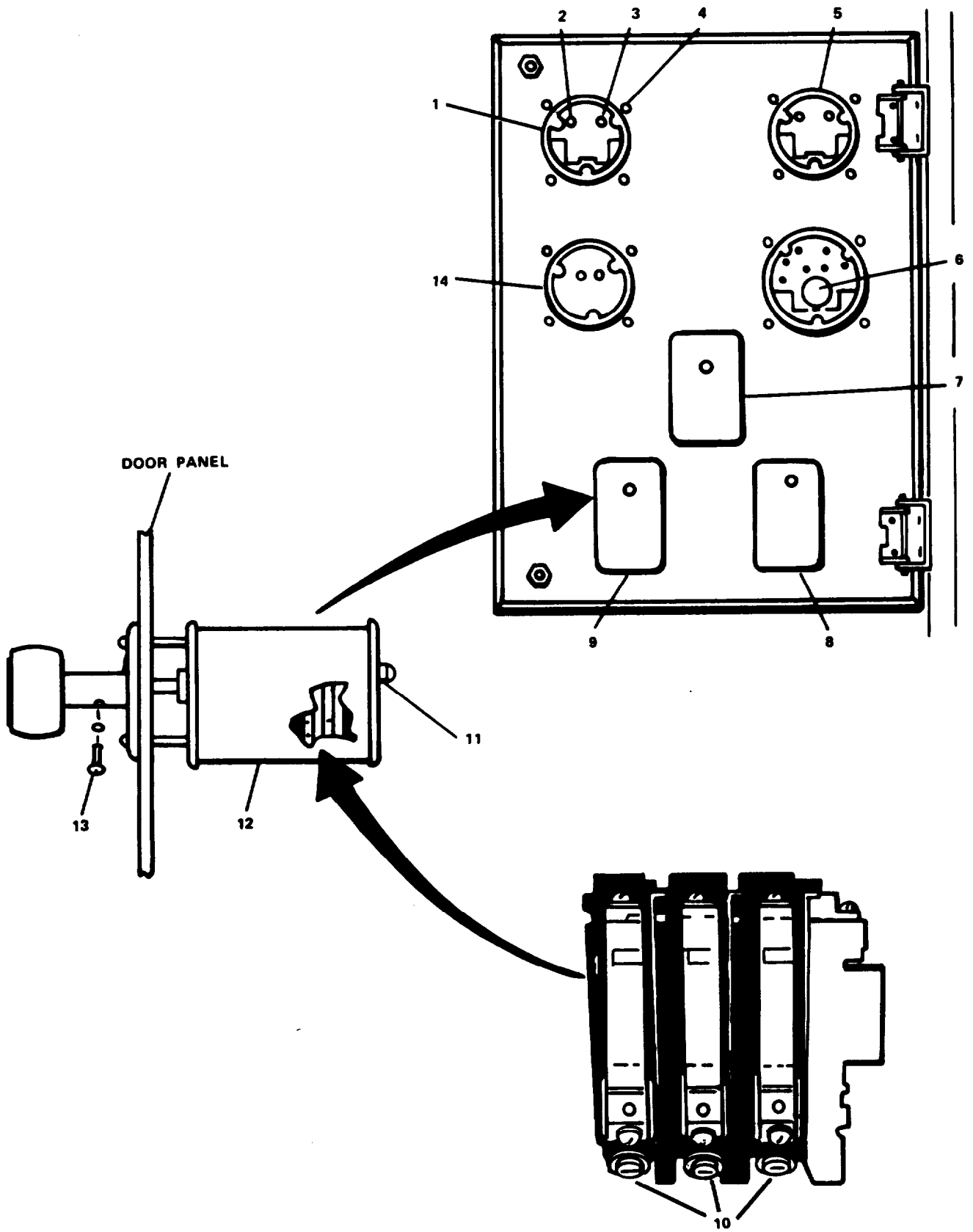


FIGURE 2-209. Ship Service Switchboard Top Left Center Panel (Rear).

## TM 55-1905-223-24-18-1

- c. Turn door panel screws (2) counterclockwise to loosen.
- d. Swing door panel (12) left to open.
- e. Tag wiring to ammeter (1) FIGURE 2-209), remove nuts (2) from meter terminals (3) and disconnect wiring.
- f. Repeat step e. for voltmeter (5), wattmeter (6), and frequency meter (14).
- g. Remove captive screw (11) and protective switch cover (12).
- h. On rotary switch (9) tag and disconnect wiring to switch terminals (10).
- i. Repeat step e. for rotary switches (7, 8).
- j. Remove nuts (4) one each from four mounting studs on each meter (1, 5, 6, and 14).
- k. Remove meters (3, 4, 10 and 11, FIGURE 2-208 from front of panel door (12).
- l. Remove rotary switch handles (6, 7, and 8) by removing set screw and washer (13), FIGURE 3-166) from the underneath side of each handle and sliding handle off shaft.
- m. Remove screws (9) FIGURE 2-208 from rotary switches (6, 7, and 8).
- n. Remove each switch (6, 7, and 8) from rear until shaft clears door panel (12).
- o. Turn door panel screws (3, FIGURE 2-210) counterclockwise.
- p. Remove door panel (6) using handrail (2). Store panel (5) in safe and out-of-way place.

### NOTE

For disassembly of circuit breaker (1, 4, and 5 FIGURE 2-210) refer to paragraph 2-217.

- q. Disassemble circuit breakers (1, 4, and 5).

### **REPAIR**

Repair is by replacement of light indicators (1, 5 FIGURE 2-208), meters (3, 4, 10, 11), rotor switches (6, 7, and 8 FIGURE 2-209), circuit breakers (1, 4, and 5, FIGURE 2-210 and lamps.

### **ASSEMBLY**

- a. Install incandescent lamps into each light lens (1, 5, FIGURE 2-208) socket.

- b. Install light lens (1, 5) and screw on each light lens collar on its respective socket until finger tight.
- c. Install each rotary switch (6, 7, 8 FIGURE 2-209) from rear of door panel and align screw holes.
- d. Install screws (9, FIGURE 2-208) in each rotary switch (5, 6, and 7) and tighten.
- e. Install each switch handle (6, 7, and 8 FIGURE 2-208) on each switch shaft and insert set screw and washer (13, FIGURE 2-209) in each handle (6, 7, and 8) and tighten.
- f. Connect wiring to each rotor switch terminals (10, FIGURE 2-208).
- g. Install protective switch cover (12) on each rotary switch (7, 8, 9) and install a captive screw (11) on each.
- h. Install meters (3, 4, 10, and 11) from front side of door panel (12) as follows:
  - (1) Install one nut (4, FIGURE 2-209) on each of four mounting studs of meter (1) and tighten.
  - (2) Connect wiring (2) to meter terminals (3) with nuts and tighten.
- i. Repeat step h. (1) and (2) for voltmeter (5), wattmeter (6) and frequency meter (4).

**NOTE**

For assembly of circuit breaker (1, 4, and 5 FIGURE 2-210) refer to paragraph 2-291.

- j. Assemble circuit breakers (1, 4, and 5, FIGURE 2-210).
- k. Close door panel (12).
- l. Turn door panel screws (2) clockwise until tight.
- m. Install door panel (6).
- n. Turn door panel screws (3) clockwise until tight.
- o. Turn ON power to ship service switchboard. Remove tag.
- p. Turn ON circuit breakers.
- q. Check operation of indicators, meters, and switches. Refer to TM 55-1905-223-10.

**TEST**

Refer to paragraph 2-291.

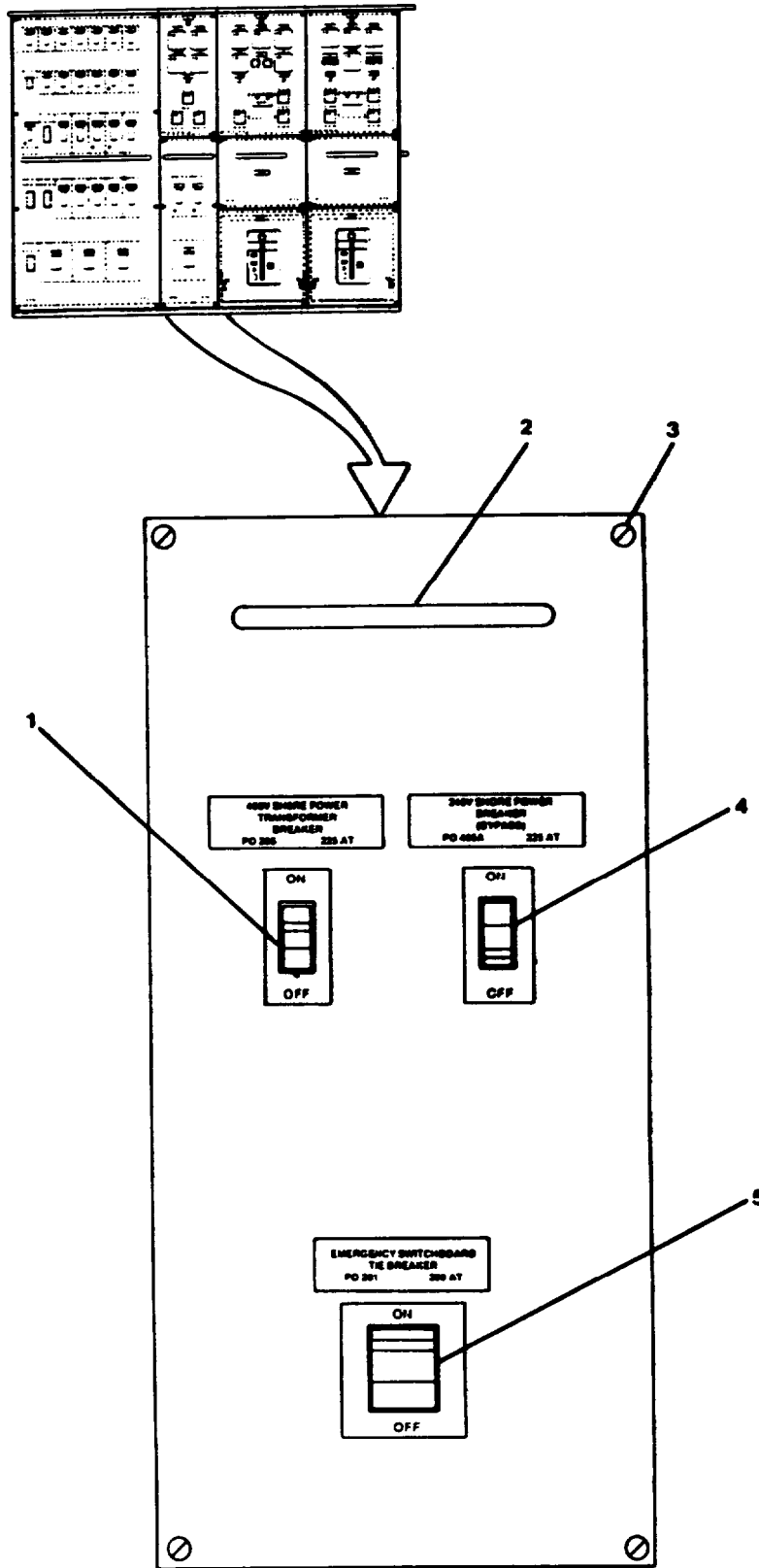


FIGURE 2-210. Ship Service Switchboard Lower Left Center Panel.

---

**2-293. Repair Ship Service Switchboard Indicators, Meters, Switches, Variable Resistor, Rheostat, and Circuit Breaker.**

---

This task covers: a. Disassembly, b. Repair, c. Assembly, d. Test.

---

**INITIAL SETUP**

**Tools**

Tool kit, electrician's,  
5180-00-391-1087

**Equipment Condition**

Power to ship service switchboard OFF, locked out, and tagged "Out of Service - Do Not Operate".  
All switchboard circuit breakers OFF.

**Materials/Parts**

Voltmeter P/N 50-103021PZR  
Watt meter P/N 50-103221ARBU7CNA  
Ammeter P/N 50-103131LSS  
Synchroscope P/N 50-106452AAAA  
Frequency meter P/N 50-103372ANAN  
Incandescent lamp P/N 6S6-6-120V  
Light lens P/N 80-0535-300  
Indicator lamp P/N S14  
Variable resistor, P/N 534  
Rheostat P/N SA502A  
Rotary switch P/N 6SB1CA20  
Rotary switch P/N 6SB10G15  
Rotary switch P/N 6SB1CF23  
Rotary switch P/N 6SB1AA1 (Mod)  
Manual voltage regulator P/N MVR-1  
Circuit breaker P/N AKR-6D-50  
Warning tags, Item 1, Appendix C

---

**WARNING**

Electrocution, serious injury, or equipment damage can result from contact with live electrical circuits. Before beginning work on electrical systems, ensure electrical power is OFF, locked out and tagged to prevent turn on during maintenance.

**DISASSEMBLY**

- a. For disassembly of light lenses (2, 7, 9, and 10, FIGURE 2-211), meters (1, 3, 5, 6, and 17), and rotary switches (11, 12, 14, and 15) refer to paragraph 2-292 and FIGURES 2-208 and 2-209.

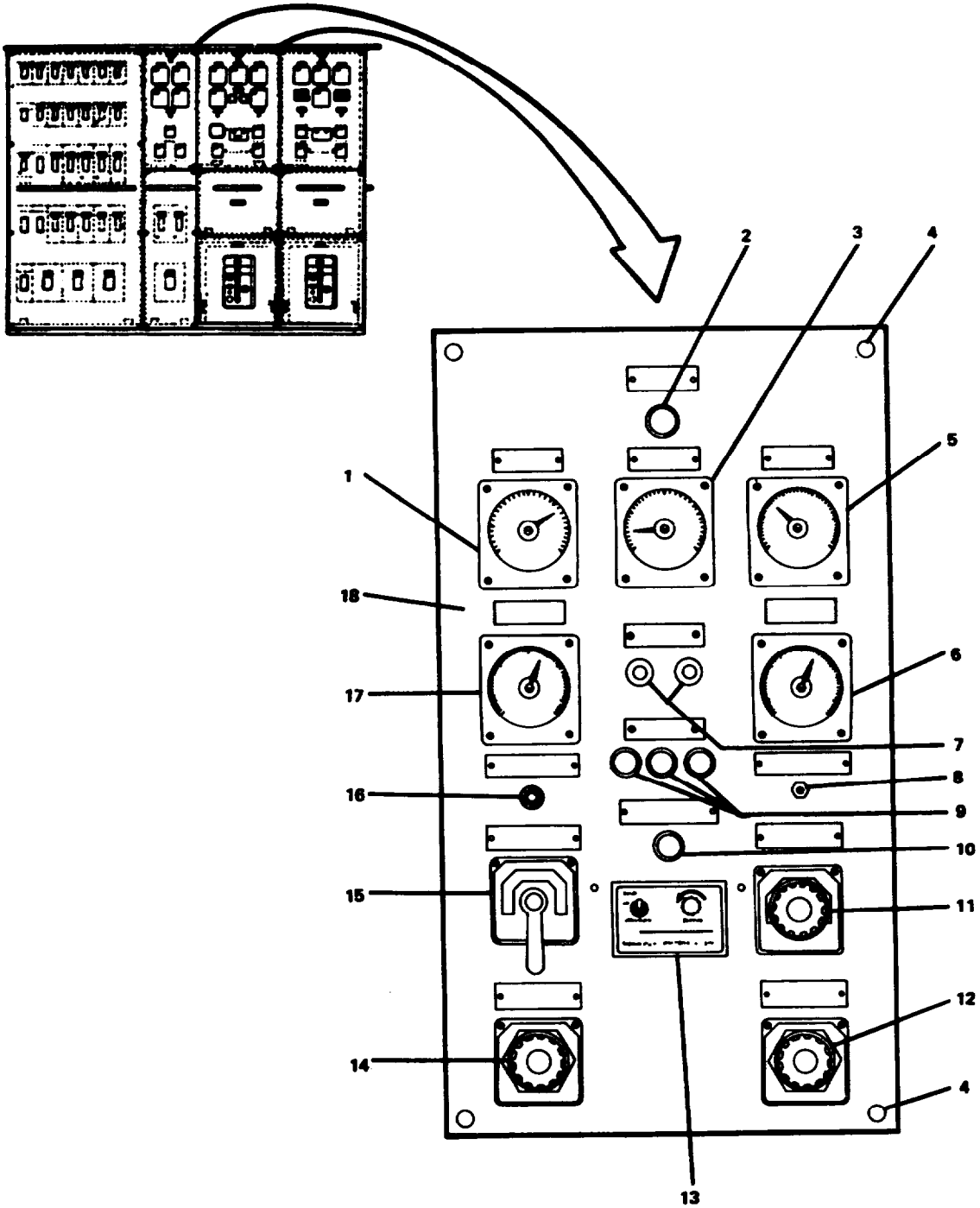


FIGURE 2-211. Ship Service Switchboard Top Right Center Panel.



- b. Remove associated hardware on rheostat (8, FIGURE 2-211).
- c. Remove associated hardware on variable resistor (16).
- d. Remove knob and associated switch hardware from front of manual voltage regulator panel (13).
- e. Turn door panel screws (4) counterclockwise.
- f. Swing door panel (18) left to open.
- g. Tag and disconnect wiring (1, FIGURE 2-212) to rheostat (2), remove rheostat.
- h. Tag and disconnect wiring (6) to variable resistor (5). remove resistor.

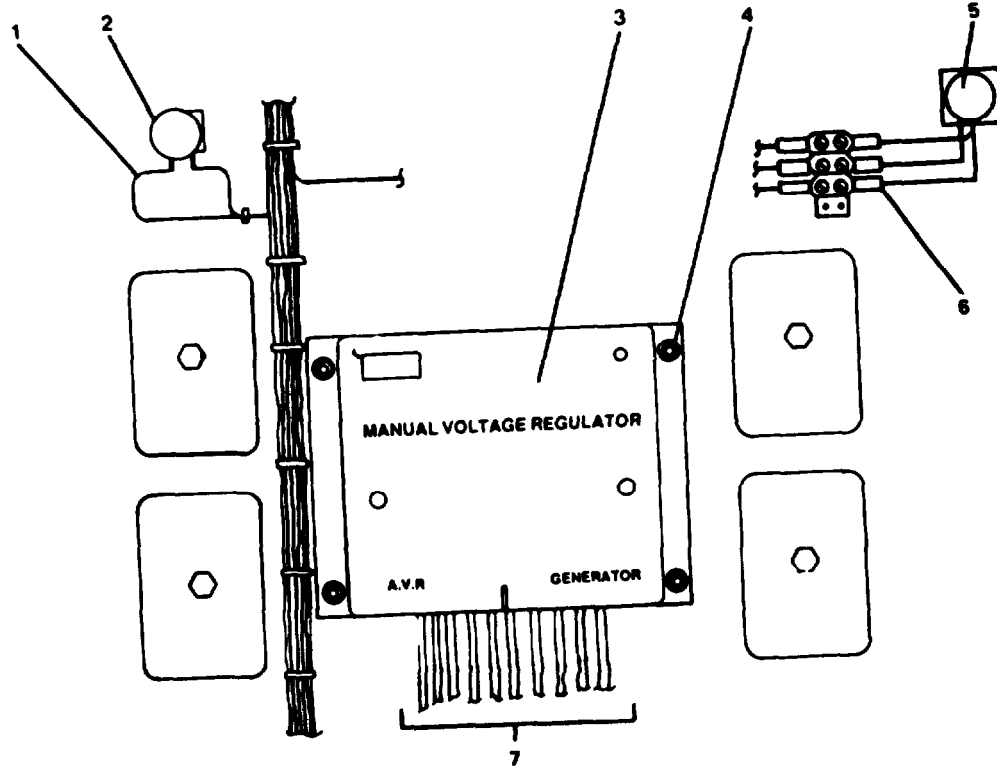


FIGURE 2-212. Ship Service Switchboard Top Right Center Panel (Rear).

## **TM 55-1905-223-24-18-1**

- i. Tag and disconnect wiring (7) to manual voltage regulator (3).
  - (1) Remove nuts (4) holding manual voltage regulator (3) to door panel.
  - (2) Remove manual voltage regulator (3).
- j. Turn door panel screws (1, FIGURE 2-213) counterclockwise to loosen.
  - (1) Remove door panel (3) using hand rail (2).
  - (2) Remove racking handle (8) from behind door panel (3).
  - (3) Store door panel (3) in safe and out-of-way place.

### **REPAIR**

Repair is by replacement of indicators, meters, switches, manual voltage regular, variable resistor, rheostat, and circuit breaker.

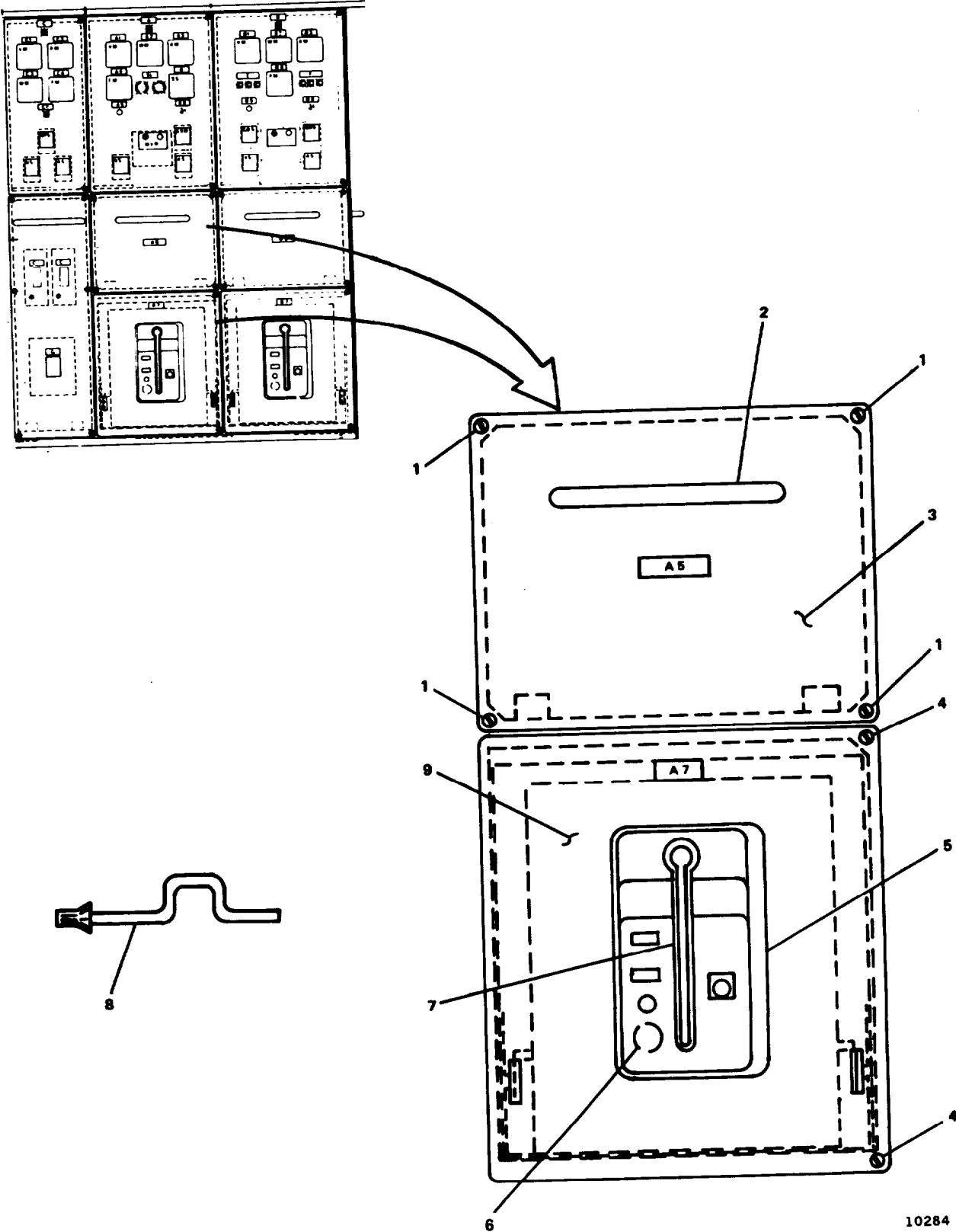
### **ASSEMBLY**

- a. Assembly of switches, meters, lamps, and lenses refer to paragraph 2-292 and FIGURES 2-208 and 2-209.
- b. Install manual voltage regulator (3, FIGURE 2-212) with nuts (4) and tighten.
- c. Connect wiring (7) to manual voltage regulator (3) and remove tags.
- d. Connect wiring (1, FIGURE 2-212) to rheostat (2) and remove tags.
- e. Install rheostat (2).
- f. Connect wiring (6, FIGURE 2-212) to resistor (5) and remove tags.
- g. Install resistor (5).
- h. Install associated hardware on rheostat (8, FIGURE 2-211).
- i. Install associated hardware in resistor (16).
- j. Install knob and associated switch on manual voltage regulator (13).
- k. Close panel door (18).
- l. Turn panel door screws (4) clockwise until tight.

### **NOTE**

Before installing circuit breaker observe the following precautions.

- (1) Ensure area is free and clean of foreign objects.



10284

FIGURE 2-213. Ship Service Switchboard Middle and Lower Right Center Panels.

**TM 55-1905-223-24-18-1**

- (2) Verify it is correct breaker.
  - (3) Ensure circuit breakers are OPEN.
  - (4) Apply a thin coat of lubricant to breaker's primary disconnects.
  - (5) Ensure racking cams on breaker are positioned for engagement with pins in compartment.
- j. Insert racking handle (8, FIGURE 2-213) into racking screw hole (2, FIGURE 2-214) and turn counterclockwise until jack screw comes to solid stop. Remove racking handle (8).
  - k. Attach suitable lifting device and spreader rig and raise circuit breaker (1) above elevation of tracks.
  - l. Slowly lower and guide circuit breaker (1) until circuit breaker (1) mounting pins drop into track slots of substructure (3).
  - m. Remove lifting device and spreader rig.
  - n. Manually push circuit breaker (1) in until it reaches track stops (DISCONNECT position).
  - o. Close door panel (9, FIGURE 2-213).
  - p. Turn door panel screws (4) clockwise until tight.
  - q. Insert racking handle (8) into racking screw hole (6) and turn handle (8) clockwise until jackscrew comes to solid stop (CONNECTED position). Remove racking handle (8).
  - r. Store racking handle (8, FIGURE 2-213) behind door panel (3).
  - s. Install door panel (3).
  - t. Turn door panel screws (1) clockwise until tight.
  - u. Turn ON power to ship service switchboard. Remove tag.
  - v. Turn ON circuit breaker.
  - w. Check operation of indicator;, meters, switches, variable resistor and rheostat and circuit breaker.

**TEST**

Refer to paragraph 2-291.

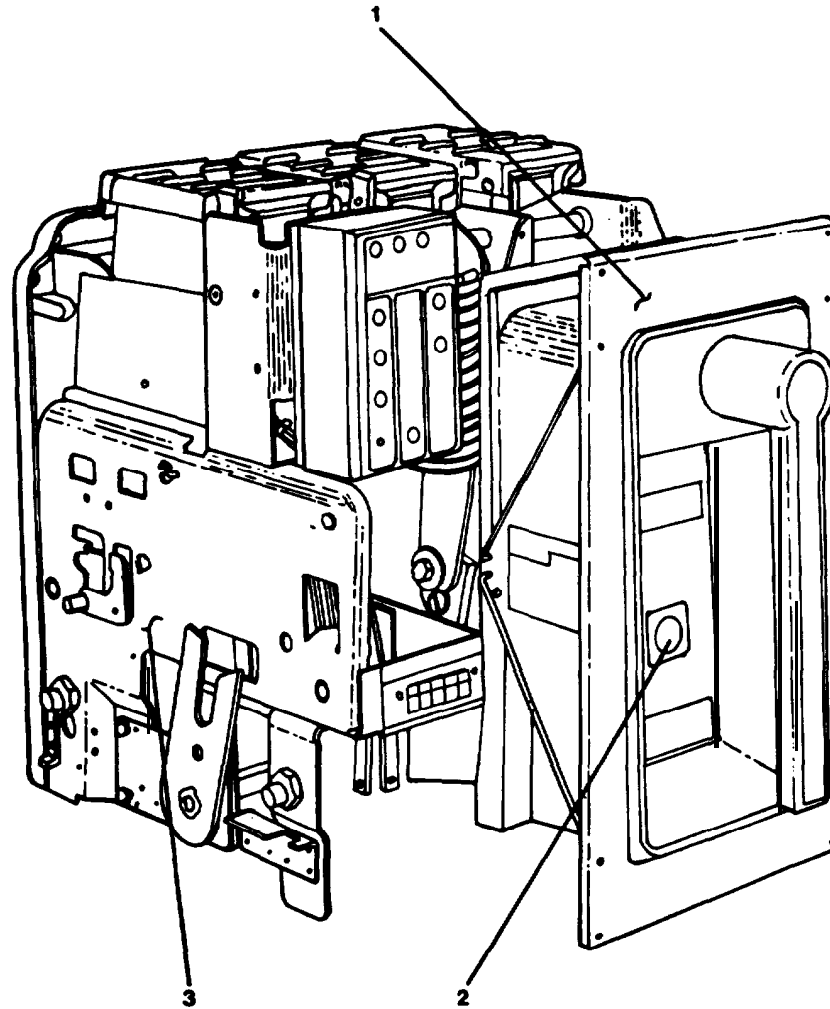


FIGURE 2-214. Circuit Breaker.

---

**2-294. Ship Service Switchboard Indicators, Gauges, Meters, Switches, Variable Resistor, Rheostat, Circuit Breaker.**

---

This task covers: a. Disassembly, b. Repair, c. Assembly, d. Test.

---

**INITIAL SETUP**

**Tools**

Tool kit, electrician's,  
5180-00-391-1087

**Materials/Parts**

Voltmeter P/N 50-103021PZR  
Incandescent lamps P/N 686-6120V  
Wattmeter P/N 50-103221ARBU7CNA  
Rheostat P/N SA502A  
Variable resistor P/N 534  
Rotary switch P/N 16SB1AA1 (Mod)  
Rotary switch P/N 16SB1CA20  
Rotary switch P/N 16SB1CF23  
Rotary switch P/N 16SB1AA1 (Mod)  
Ammeter P/N 50-103131LSSS  
Manual voltage regulator P/N MVR-1  
Light lenses P/N 80-0535-300  
Frequency meter P/N 50-1033-72ANAN  
Circuit breaker P/N AKR-5D-50  
Warning tags, Item 1, Appendix C

**Equipment Condition**

Power to ship service switchboard OFF,  
locked out, and tagged "Out of  
Service - Do Not Operate."  
All switchboard circuit breakers OFF.

---

**WARNING**

Electrocution, serious injury, or equipment damage can result from contact with live electrical circuits. Before beginning work on electrical systems, ensure electrical power is OFF, locked out and tagged to prevent turn on during maintenance.

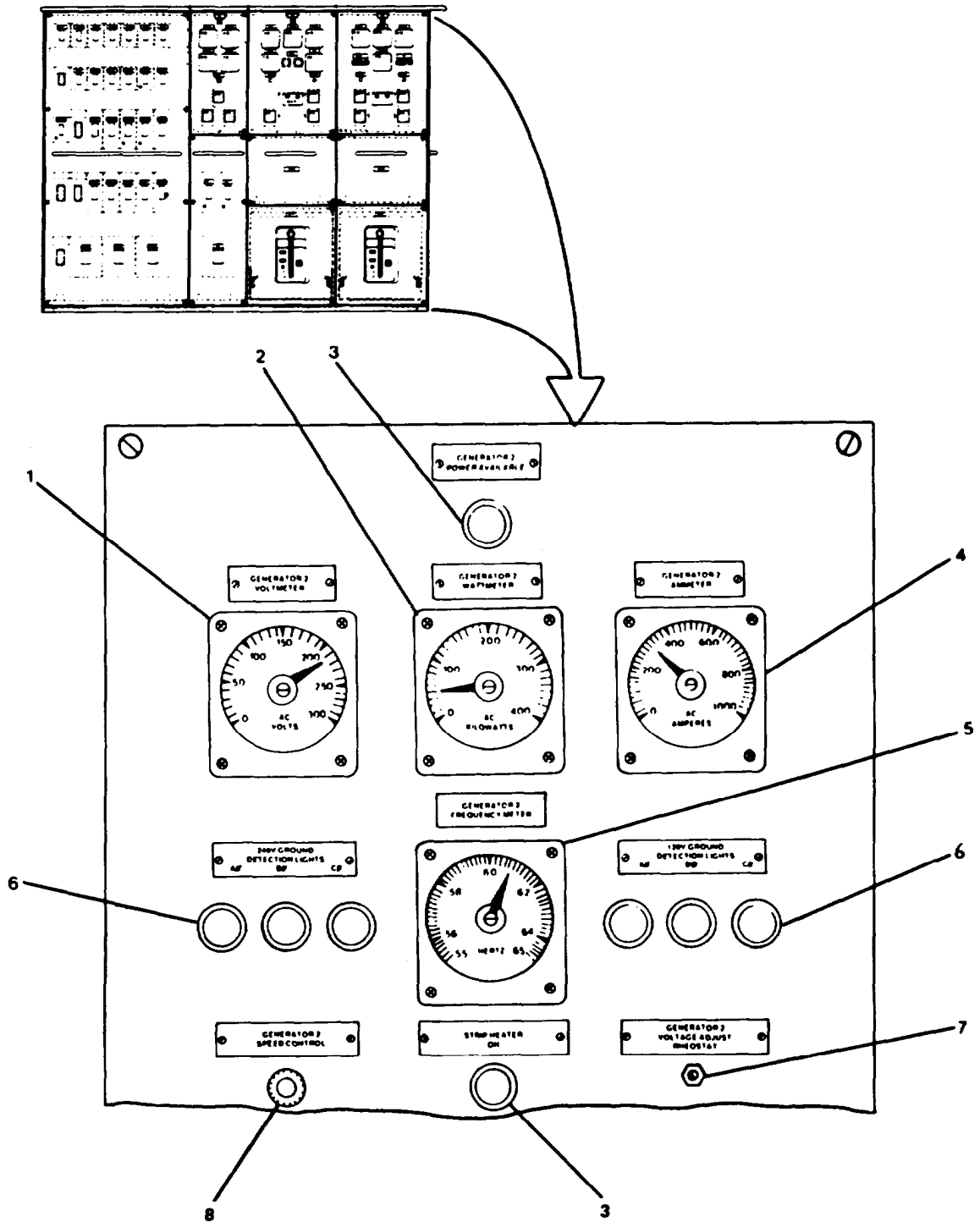


FIGURE 2-215. Ship Service Switchboard Right Hand Panels.  
(Sheet 1 of 2)

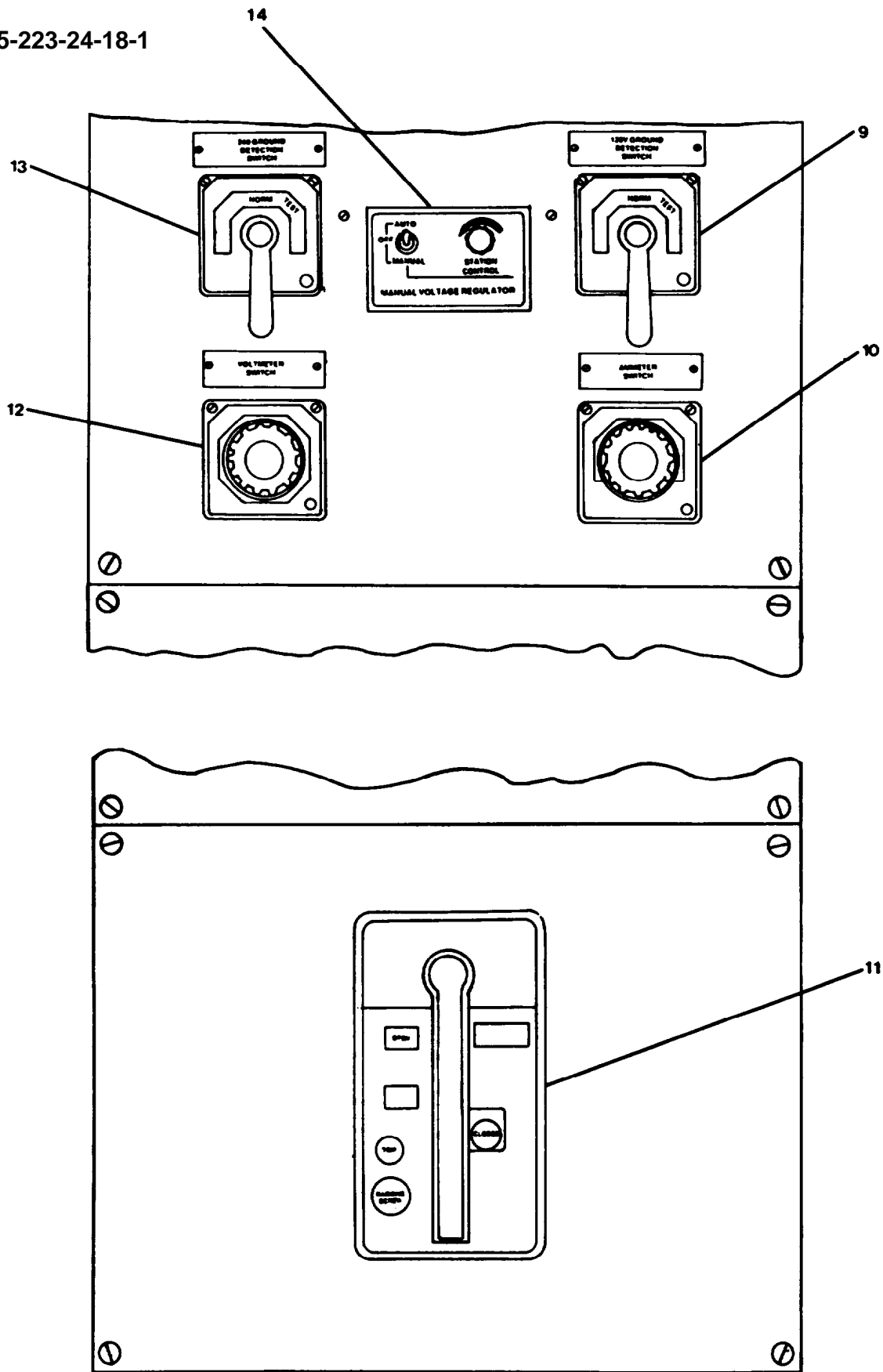


FIGURE 2-215. Ship Service Switchboard Right Hand Panels.  
(Sheet 2 of 2)



**DISASSEMBLY**

- a. For disassembly of light lenses (3 and 6, FIGURE 2-215), meters (1, 2, 4, 5), and rotary switches (9, 10, 12, and 13) refer to paragraph 2-292.
- b. For disassembly of rheostat (7), variable resistor (8), and manual voltage regulator (14) refer to paragraph 2-293.
- c. For disassembly of circuit breaker (11) refer to paragraph 2-293.

**REPAIR**

Repair is by replacement of meters (1, 2, 4, and 5) light indicators (3 and 6) rheostat (7), variable resistor (8), rotary switches (9, 10, 12, and 13), circuit breaker (11), manual voltage regulator (14) and lamps.

**ASSEMBLY**

Refer to paragraph 2-292 for assembly of meters, light lenses, and rotary switches and 2-293 for circuit breaker, rheostat, and manual voltage regulator.

**TEST**

Refer to paragraph 2-291.

---

**2-295. Repair Ship Service Switchboard Current Transformers. (FIGURE 2-216)**

---

This task covers: a. Disassembly, b. Repair, c. Assembly, d. Test.

---

**INITIAL SETUP**

**Tools**

Tool kit, electrician's,  
5180-00-391-1087

**Equipment Condition**

Power to ship service switchboard OFF,  
locked out, and tagged "Out of  
Service - Do Not Operate."

**Materials/Parts**

Current transformer P/N 74R-251  
Current transformer P/N 100R-102  
Warning tags, Item 1, Appendix C

---

**WARNING**

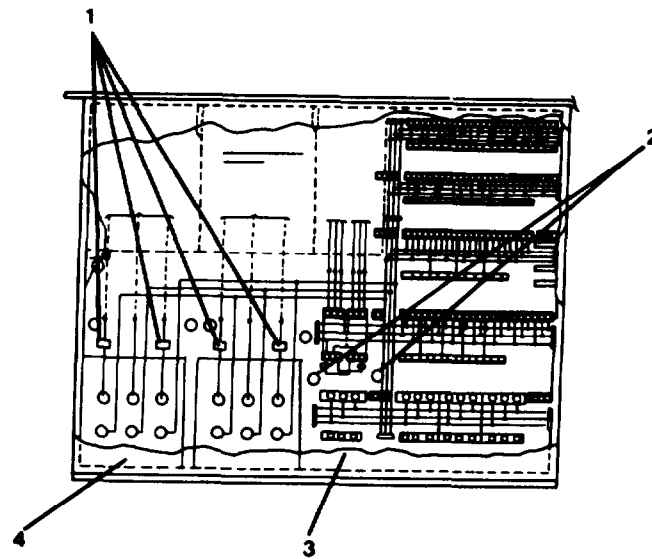
Electrocution, serious injury, or equipment damage can result from contact with live electrical circuits. Before beginning work on electrical systems, ensure electrical power is OFF, locked out and tagged to prevent turn on during maintenance.

**DISASSEMBLY**

- a. Remove bolt-on flat sheets (3, 4).
- b. Tag and disconnect wiring to transformers (1, 2).
- c. Remove associated hardware and transformers (1, 2).

**REPAIR**

Repair to transformers is by replacement of transformers.



9791

FIGURE 2-216. Ship Service Switchboard Rear View.

**ASSEMBLY**

- a. Install transformers (1, 2) with associated hardware.
- b. Connect wiring to transformers (1, 2) and remove tags.
- c. Install bolt-on flat sheets (3, 4).

**TEST**

Refer to paragraph 2-291.

---

**2-296. Repair Ship Service Switchboard Circuit Breakers. (FIGURE 2-217)**

---

This task covers: a. Disassembly, b. Repair, c. Assembly, d. Test.

---

**INITIAL SETUP****Tools**

Tool kit, electrician's,  
5180-00-391-1087

**Materials/Parts**

Circuit breakers P/N TFJ236175,  
P/N THQL32045, P/N THQL32080  
Warning tags, Item 1, Appendix C

**Equipment Condition**

Power to main switchboard OFF, locked  
out, and tagged "Cut of Service - Do  
Not Operate."  
All switchboards circuit breakers OFF.

---

**WARNING**

Electrocution, serious injury, or equipment damage can result from contact with live electrical circuits. Before beginning work on electrical systems, ensure electrical power is OFF, locked out and tagged to prevent turn on during maintenance.

**DISASSEMBLY**

- a. Remove bolt-on cover plate (2).
- b. Remove any associated hardware from circuit breakers (1).
- c. Pull circuit breakers (1) straight out to remove.

**REPAIR**

- a. Repair circuit breakers by replacement.

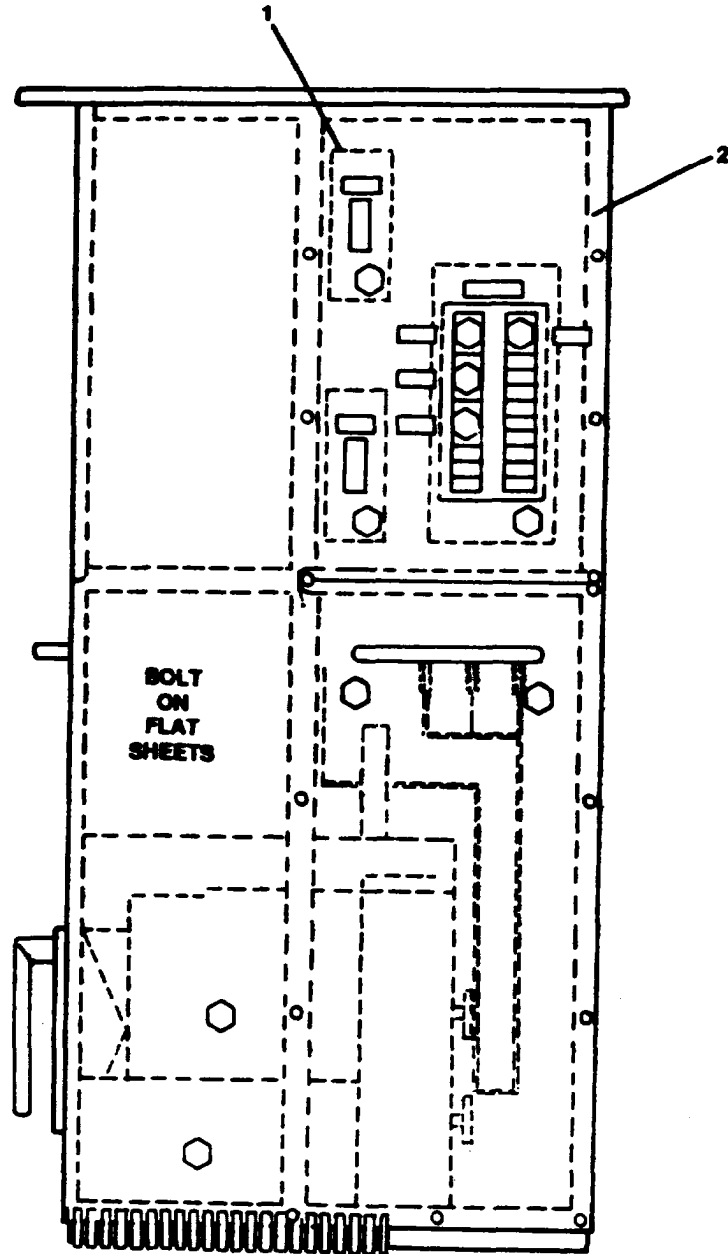


FIGURE 2-217. Ship Service Switchboard Side View Top Right.

**ASSEMBLY**

- a. Install circuit breakers (1) by pushing straight in.
- b. Install any associated hardware.
- c. Install bolt-on cover plate (2).

**TEST**

Refer to paragraph 2-291.

**2-297. Repair Ship Service Switchboard Fuse Panel. (FIGURE 2-218)**

---

This task covers: a. Disassembly, b. Repair, c. Assembly, d. Test.

---

**INITIAL SETUP**

**Tools**

Tool kit, electrician's,  
5180-00-391-1087

**Equipment Condition**

Power to main switchboard OFF, locked out, and tagged "Cut of Service - Do Not Operate."  
All switchboard circuit breakers OFF.

**Materials/Parts**

Cartridge fuses P/N BAF 3  
Block fuseholder P/N 2808  
Voltage transformer P/N 46012-240,  
P/N 460R-480  
Power transformer P/N B050BTZ13  
Current transformer P/N 74R-251  
Current transformer P/N 100R-102  
Terminal boards P/N EB27A04S,  
P/N CR151B2, P/N CR1S1B6  
Voltage relay P/N BE4-27/59-3A1N3  
Current relay P/N BE4-51-1E1A1  
Reverse power relay P/N BE4-32-3A1N1  
Frequency relay P/N BE4-B810/U-1A4N1  
Electromagnetic relay P/N PM17AY120V  
Electrical cover P/N 35D203  
Warning tags, Item 1, Appendix C

---

**WARNING**

Electrocution, serious injury, or equipment damage can result from contact with live electrical circuits. Before beginning work on electrical systems, ensure electrical power is OFF, locked out and tagged to prevent turn on during maintenance.

**DISASSEMBLY**

- a. Open door panels (1).
- b. Remove cartridge fuses from block fuseholders (3).
- c. Tag and disconnect wiring to block fuseholders (3).



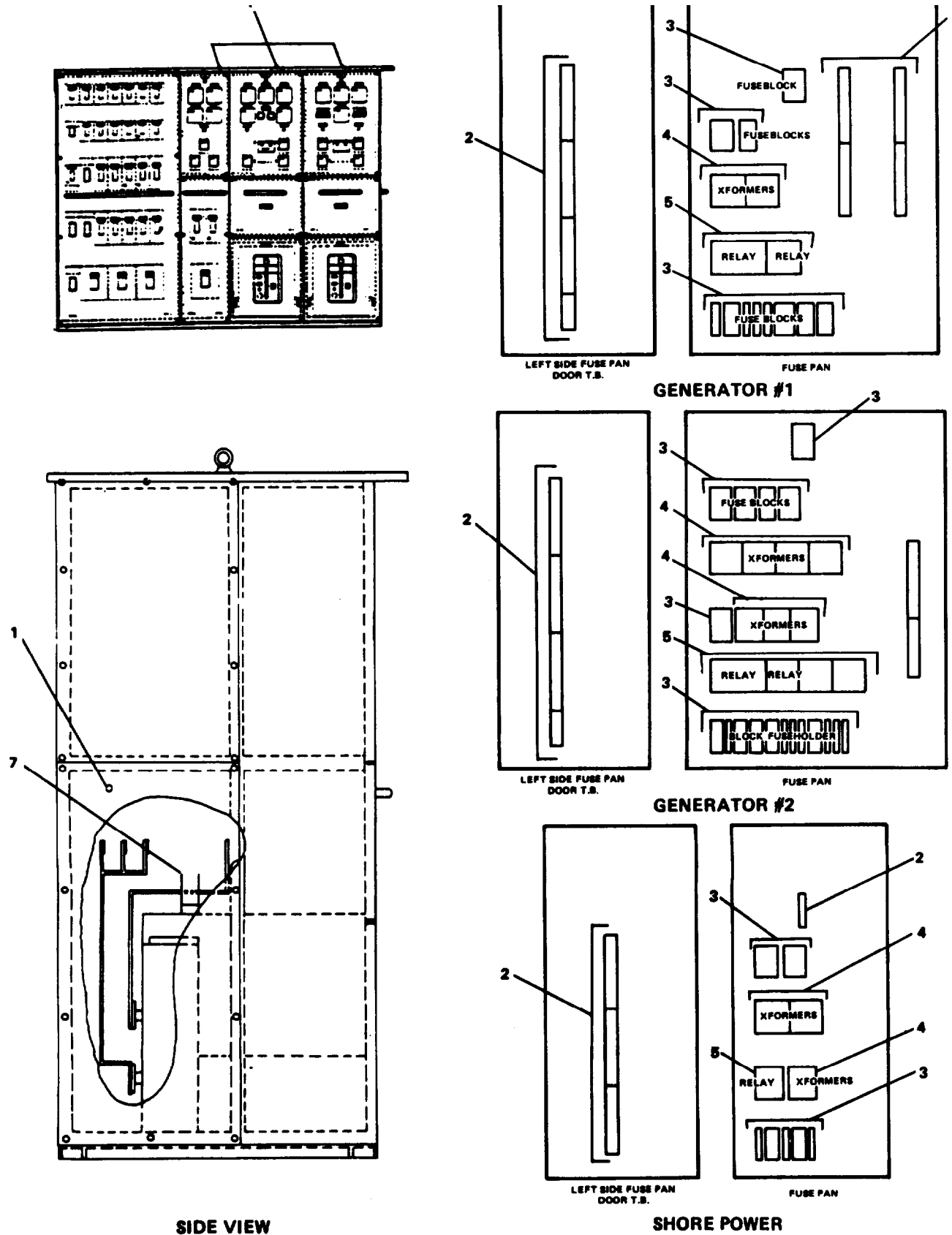


FIGURE 2-218. Ship Service Switchboard Fuse Pan.

## **TM 55-1905-223-24-18-1**

- d. Remove associated hardware and block fuseholder (3).
- e. Tag and disconnect wiring to all transformers (4, 7).
- f. Remove associated hardware and all transformers (4, 7).
- g. Tag and disconnect wiring to all relays (5).
- h. Remove associated hardware and all relays (5).
- i. Tag and disconnect wiring to terminal boards (2).
- j. Remove associated hardware and terminal boards (2).

### **REPAIR**

Repair is by replacement of cartridge fuses, block fuseholders, transformers, relays, and terminal boards.

### **ASSEMBLY**

- a. Install terminal boards (2) with associated hardware.
- b. Connect wiring to terminal boards (2) and remove tags.
- c. Install relays (5) with associated hardware.
- d. Connect wiring to relays (5) and remove tags.
- e. Install all transformers (4, 7) with associated hardware.
- f. Connect wiring to transformers (4, 7) and remove tags.
- g. Install block fuseholder (3) with associated hardware.
- h. Connect wiring to block fuseholder (3) and remove tags.
- i. Install cartridge fuses into fuseholders (3).
- j. Close door panels (1) and secure.
- k. Turn ON electrical power to switchboard.
- l. Turn ON all circuit breakers.

### **TEST**

Refer to paragraph 2-291.

---

**2-298. Repair Emergency Generator Switchboard. (FIGURE 2-219)**

---

This task covers: a. Disassembly, b. Repair, c. Assembly, d. Test.

---

**INITIAL SETUP****Tools**

Tool kit, electrician's,  
5180-00-391-1087

**Materials/Parts**

Voltmeter P/N 50-103021PZR  
Wattmeter P/N 50-103221ARBU7BYA  
Frequency meter P/N 50-103372ANAN  
Ammeter P/N 50-103131LSRL  
Incandescent lamps P/N 6S6-6-120V  
Light lenses P/N 80-0531-300,  
P/N 80-0532-300, P/N 80-0535-300,  
P/N 80-0537-300  
Rheostat P/N SA502A  
Rotary switches P/N 16SB1AA1,  
P/N 16SB1CA20, P/N 16SB1B1  
Warning tags, Item 1, Appendix C

**Equipment Condition**

Power to emergency generator  
switchboard OFF, locked out, and  
tagged "Out of Service - Do Not  
Operate."

---

**WARNING**

Electrocution, serious injury, or equipment damage can result from contact with live electrical circuits. Before beginning work on electrical systems, ensure electrical power is OFF, locked out and tagged to prevent turn on during maintenance.

**DISASSEMBLY**

For disassembly of meters (1, 2, 4, and 6), light lenses (3, 7, and 11), rheostat (8), rotary switches (9, 10, 12, 13, 14), and incandescent lamps refer to paragraph 2-293.

**REPAIR**

Repair to emergency generator switchboard is by replacement meters (1, 2, 4, and 6, FIGURE 2-219), light lenses (3, 7, and 11), rheostat (8), rotary switches (9, 10, 12, 13, and 14), and incandescent lamps.

**ASSEMBLY**

Assembly of replacement components refer to paragraph 2-291.

**TEST**

- a. Set 240 VOLT GROUND TEST (14, FIGURE 2-219) to TEST position.
- b. Three 240V GROUND DETECTION LIGHTS (7) remain lit.

**NOTE**

If an indicator dims or goes out it indicates a ground fault condition.

- c. Set 240 VOLT GROUND TEST (14) to NORMAL position.
- d. Set 120V GROUND DETECTION SWITCH (9) to TEST position.
- e. Three 120V GROUND DETECTION LIGHTS (7) remain lit.

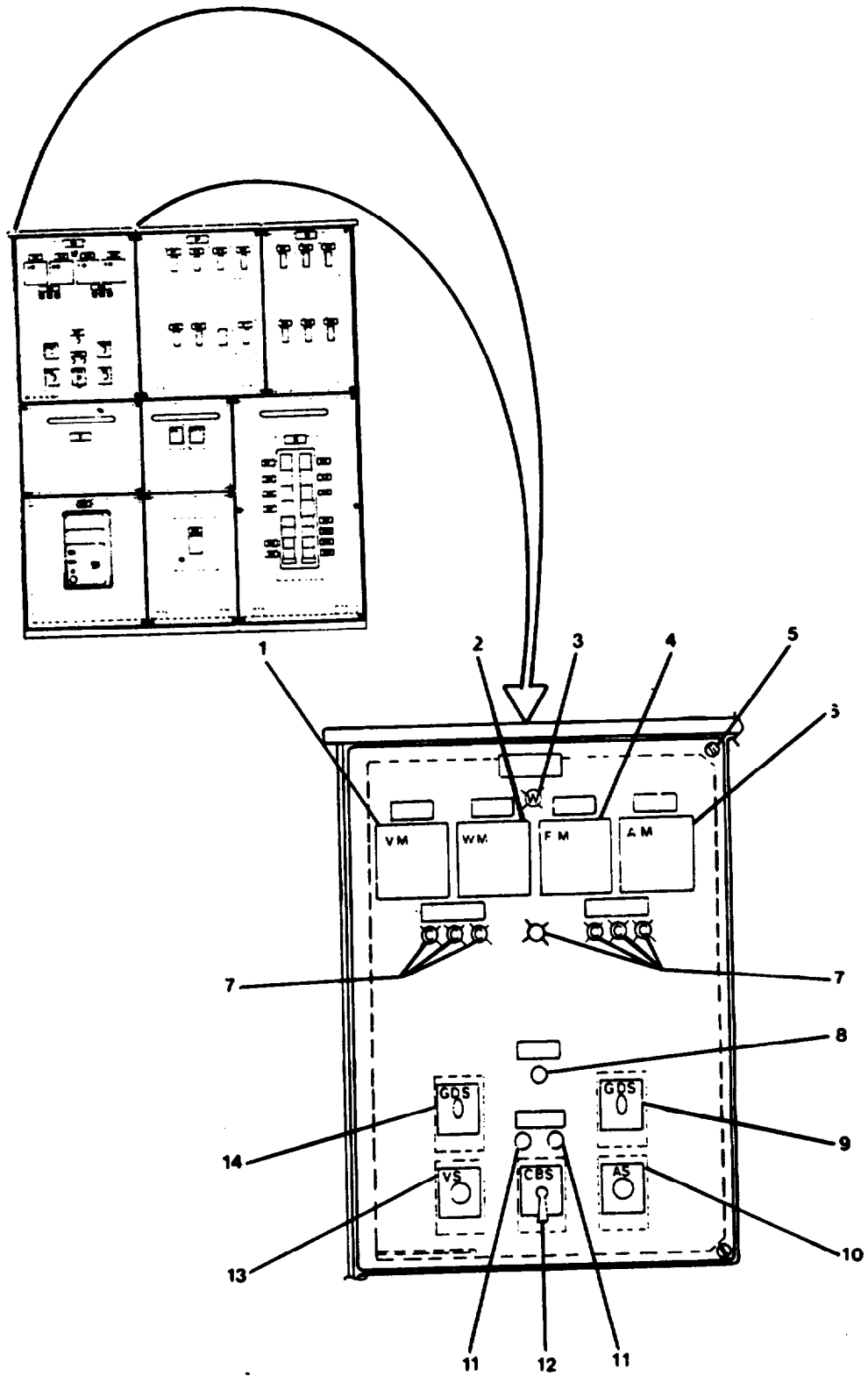


FIGURE 2-219. Emergency Generator Switchboard Top left Panel.

**2-299. Repair Emergency Generator Switchboard Circuit Breakers. (FIGURE 2-220)**

---

This task covers: a. Removal, b. Repair, c. Replacement, d. Test.

---

**INITIAL SETUP**

**Tools**

Tool kit, electrician's  
5180-00-391-1087

**Materials/Parts**

Circuit breakers P/N TEED136080  
P/N THED136015  
P/N TEC365C5050 with auxiliary  
switch P/N TEDAS2B1-Rs and current  
limiter, P/N TECL36050  
being serviced.  
P/N THED136100  
P/N THED124C5015  
Warning tags, Item 1, Appendix C

**Equipment Condition**

Power to emergency generator  
switchboard OFF, locked out, and  
tagged "Out of Service - Do Not  
Operate."  
All switchboard circuit breakers OFF.

---

**WARNING**

Electrocution, serious injury, or equipment damage can result from contact with live electrical circuits. Before beginning work on electrical systems, ensure electrical power is OFF, locked out and tagged to prevent turn on during maintenance.

**NOTE**

Circuit breakers may have internally mounted and factory installed accessories.

**DISASSEMBLY**

For disassembly of circuit breakers (1, 2, 3, 4, 6, 7 and 8, FIGURE 2-220) refer to paragraph 2-292.

**REPAIR**

Refer to circuit breakers is by replacement.

**ASSEMBLY**

For assembly of circuit breakers refer to paragraph 2-292.

**TEST**

Refer to paragraph 2-298.

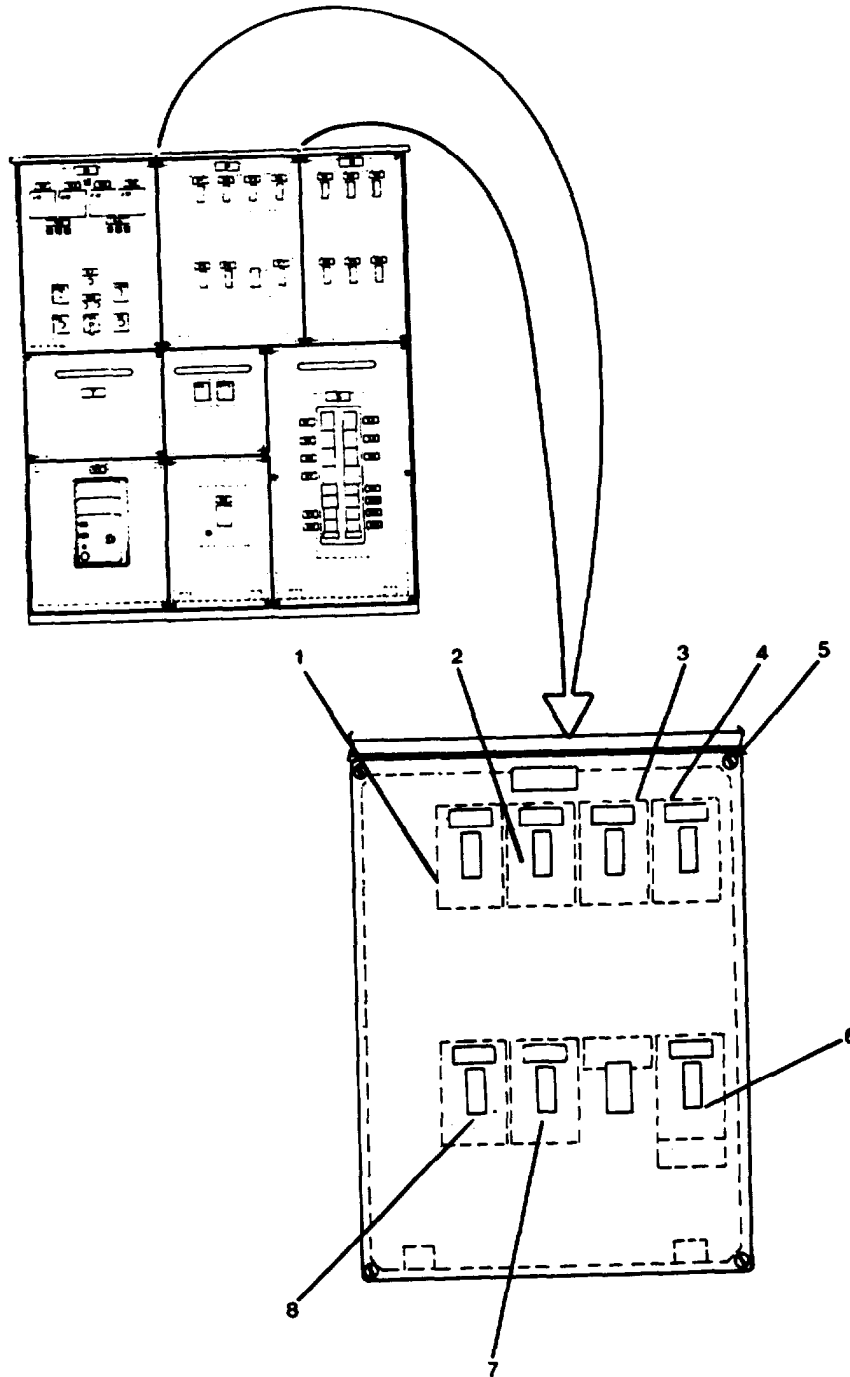


FIGURE 2-220. Emergency Generator Switchboard Top Center Panel.

---

**2-300. Replace Emergency Generator Switchboard Circuit Breakers. (FIGURE 2-221)**

---

This task covers: a. Disassembly, b. Repair, c. Assembly, d. Test.

---

**INITIAL SETUP**

**Tools**

Tool kit, electrician's,  
5180-00-391-1087

**Materials/Parts**

Circuit breakers P/N TEB122015  
Warning tags, Item 1, Appendix C

**Equipment Condition**

Power to emergency generator  
switchboard OFF, locked out, and  
tagged "Out of Service - Do Not  
Operate."  
All switchboard circuit breakers OFF.

---

**WARNING**

Electrocution, serious injury, or equipment damage can result from contact with live electrical circuits. Before beginning work on electrical systems, ensure electrical power is OFF, locked out and tagged to prevent turn on during maintenance.

**NOTE**

Circuit breakers may have internally mounted and factory installed accessories.

**DISASSEMBLY**

For disassembly of circuit breakers (1, 2, 4, 5, 6, and 7, FIGURE 2-221) refer to paragraph 2-292.

**REPAIR**

Repair to circuit breakers is by replacement.



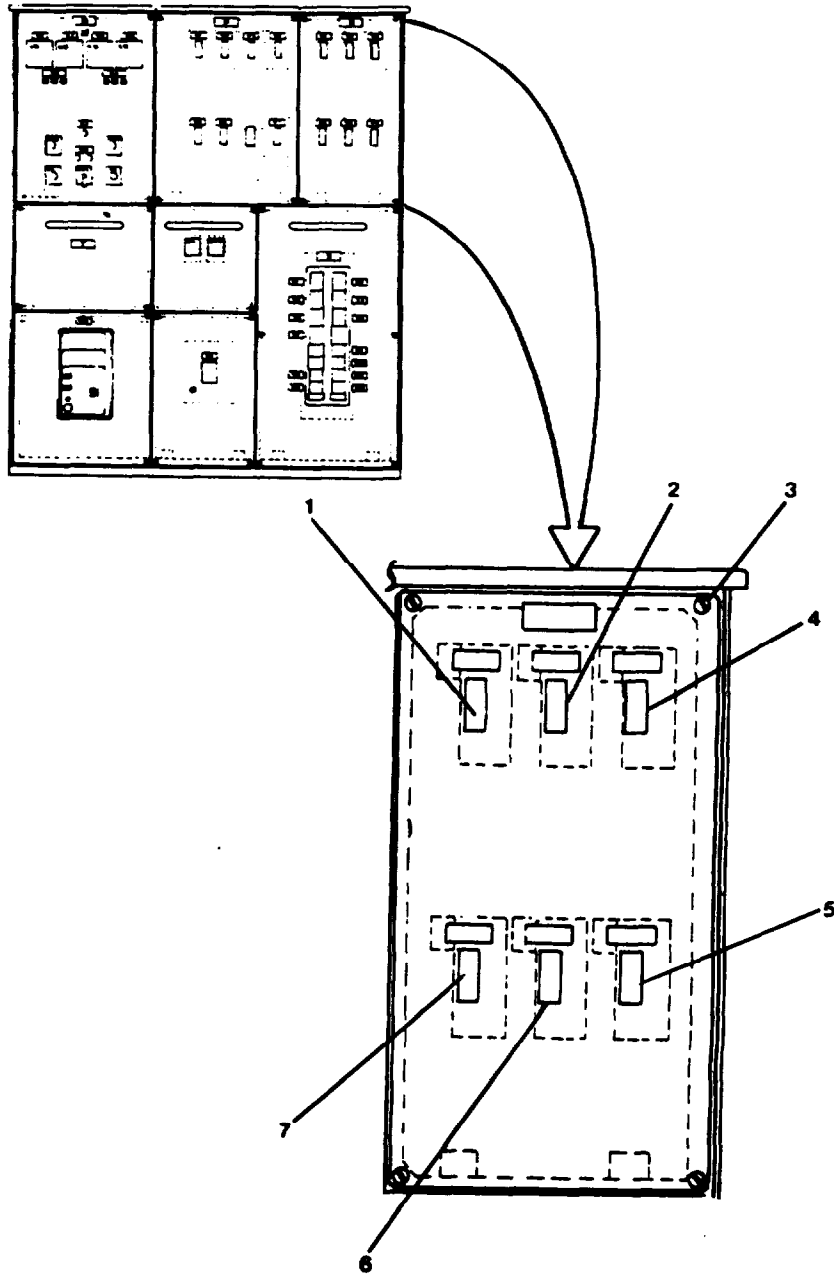


FIGURE 2-221. Emergency Generator Emergency Switchboard Top Right Panel.

**ASSEMBLY**

For assembly of circuit breakers refer to paragraph 2-292.

**TEST**

Refer to paragraph 2-298.

---

**2-301. Repair Emergency Generator Switchboard Circuit Breaker.**

---

This task covers: a. Disassembly, b. Repair, c. Assembly, d. Test.

---

**INITIAL SETUP****Tools**

Tool kit, electrician's,  
5180-00-391-1087

**Materials/Parts**

Circuit breakers P/N AKR-6D30S  
Warning tags, Item 1, Appendix C

**Equipment Condition**

Power to emergency generator  
switchboard OFF, locked out, and  
tagged "Out of Service - Do Not  
Operate."  
All switchboard circuit breakers OFF.

---

**WARNING**

Electrocution, serious injury, or equipment damage can result from contact with live electrical circuits. Before beginning work on electrical systems, ensure electrical power is OFF, locked out and tagged to prevent turn on during maintenance.

**DISASSEMBLY**

- a. Turn door panel screws (1, FIGURE 2-222) counterclockwise to loosen.
  - (1) Remove door panel (3) using hand rail (2).
  - (2) Store door panel (3) in safe and out-of-way place.

**NOTE**

Before removing circuit breaker ensure breaker is tripped and panel door closed.

- b. Trip circuit breaker by pushing circuit breaker trip button (6).

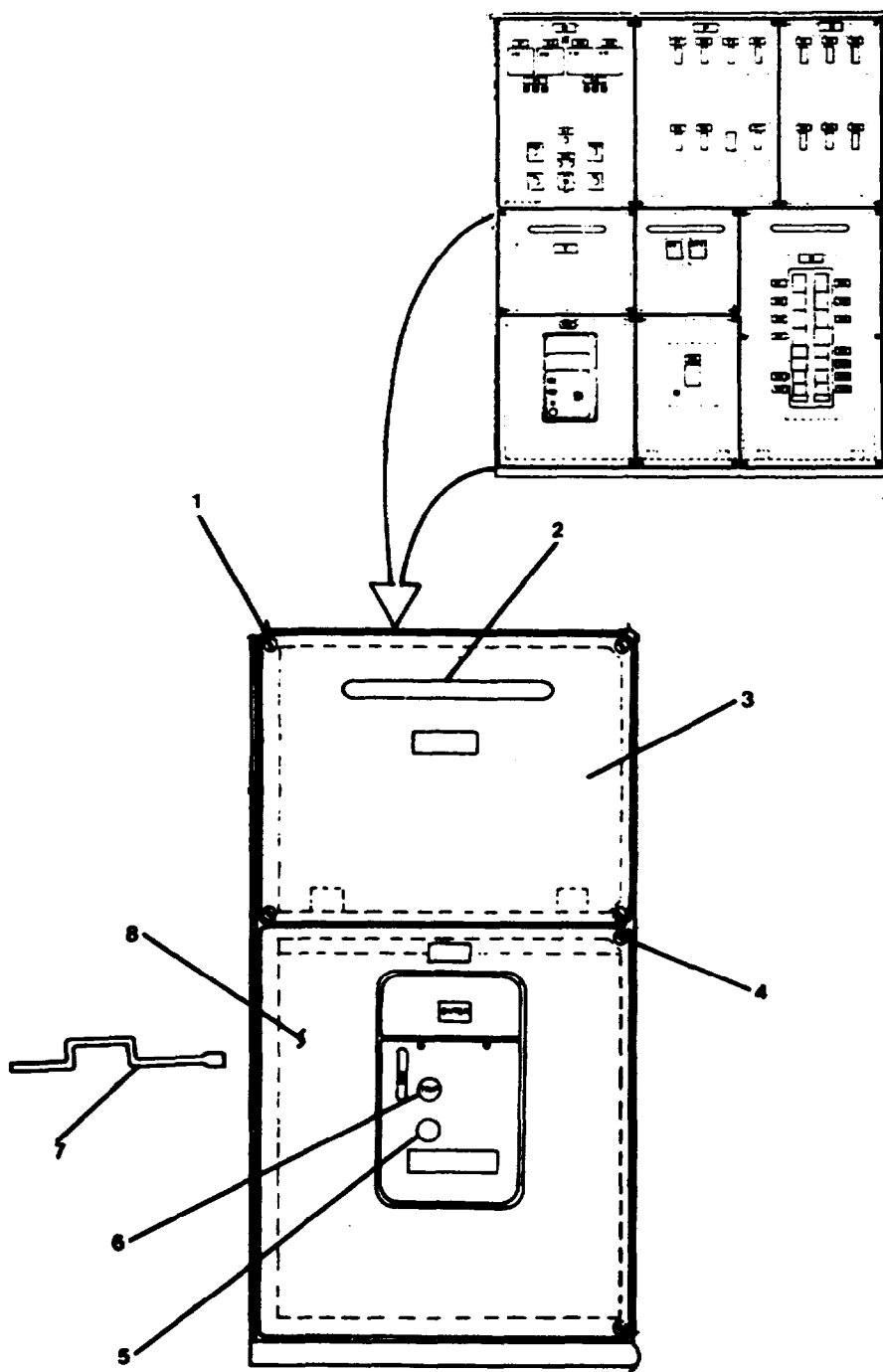


FIGURE 2-222. Emergency Generator Switchboard Middle and Bottom Left Panels.

- C. Turn door panel screws (4) counterclockwise to loosen.
  - (1) Swing door panel (9) left to open.
  - (2) Remove racking handle (7) from behind door panel (9).

**NOTE**

Racking mechanism is not used for movement of circuit breaker between DISCONNECT and WITHDRAWN positions.

- d. Insert racking handle (7) into racking screw hole (8).
- e. Rotate racking handle (7) counterclockwise until the jackscrew comes to solid stop. Circuit breaker is now in the DISCONNECT position. Remove racking handle (7).
- f. Manually pull circuit breaker (1, FIGURE 2-223) to track travel limit (WITHDRAWN position).

**NOTE**

Before removal visually check spring charge and close indicators to verify breaker is open and springs are discharged.

- g. Attach suitable lifting device to breaker (1) and hoist until mounting pins clear track slots.
  - (1) Swing breaker (1) forward until primary disconnects clear substructure (3).
  - (2) lower breaker (1) onto flat unobstructed surface.
  - (3) Remove lifting device.

**REPAIR**

Repair to circuit breakers is by replacement.

**ASSEMBLY****NOTE**

Before installing circuit breaker observe the following precautions.

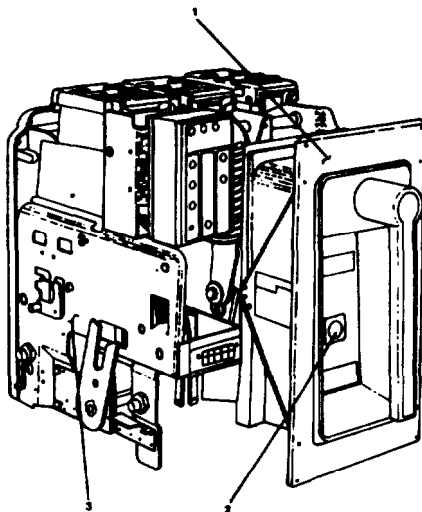
- (1) Ensure area is clean and free of foreign objects.
- (2) Verify it is correct breaker.
- (3) Ensure circuit breaker is OPEN.
- (4) Apply a thin coat of lubricant to breaker's primary disconnects.

**TM 55-1905-223-24-18-1**

- (5) Ensure racking cams on breaker are positioned for engagement with pins in compartment.
- a. Insert racking handle (7) into racking screw hole (2, FIGURE 2-223) and turn counterclockwise until jack screw comes to solid stop. Remove racking handle (7).
- b. Attach suitable lifting device and spreader rig and raise circuit breaker (1) above elevation of tracks.
- c. Slowly lower and guide circuit breaker until circuit breaker (1) mounting pins drop into track slots on substructure (3).
- d. Remove lifting device and spreader rig.
- e. Manually push circuit breaker (1) in until it reaches track stops (DISCONNECT position).
- f. Close door panel (9, FIGURE 3-179).
- g. Turn door panel screws (4) clockwise until tight.
- h. Insert racking handle (7) into racking screw hole (8) and turn handle (7) clockwise until jack screw comes to solid stop (CONNECTED position). Remove racking handle (7).
- i. Store racking handle (7) behind door panel (3).
- j. Install door panel (3).
- k. Turn door panel screws (1) clockwise until tight.

**TEST**

Refer to paragraph 2-298.



**FIGURE 2-223. Circuit Breaker.**

**2-302. Repair Emergency Generator Switchboard Circuit Breakers.**

This task covers: a. Disassembly, d. Repair, c. Assembly, d. Test.

**INITIAL SETUP**

Tools

Tool kit, electrician's,  
5180-00-391-1087

Materials/Parts

Rotary Switches P/N 16SB13P3T,  
P/N 16SB1CG30  
Circuit breaker P/N TJJ436300 with  
under voltage release, P/N TJKUVA1-  
LS  
Warning tags, Item 1, Appendix C

Equipment Condition

Power to emergency generator  
switchboard OFF, locked out, and  
tagged "Out of Service - Do Not  
Operate."  
All switchboard circuit breakers OFF.

**WARNING**

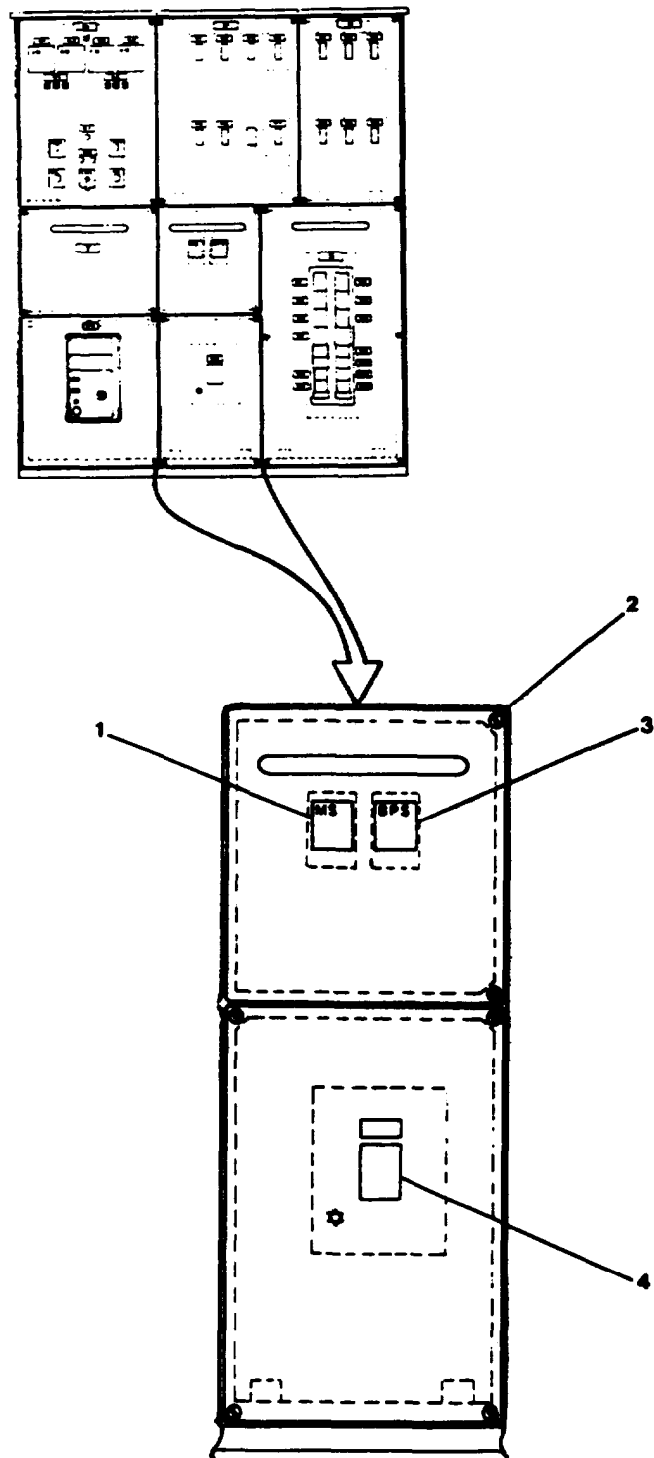
Electrocution, serious injury, or equipment damage can result from contact with live electrical circuits. Before beginning work on electrical systems, ensure electrical power is OFF, locked out and tagged to prevent turn on during maintenance.

**DISASSEMBLY**

**NOTE**

Circuit breakers may have internally mounted and factory installed accessories.

For disassembly of circuit breakers (1, 3, 4, FIGURE 2-224) refer to paragraph 2-292.



**FIGURE 2-224. Emergency Generator Switchboard Middle and Bottom Center Panels.**



**REPAIR**

Repair to circuit breaker (1, 3, 4) is by replacement.

**TEST**

Refer to paragraph 2-298.

## 2-303. Repair Emergency Generator Switchboard Circuit Breakers.

---

This task covers: a. Disassembly, b. Repair, c. Assembly, d. Test.

---

### INITIAL SETUP

#### Tools

Tool kit, electrician's,  
5180-00-391-1087

#### Materials/Parts

#### Circuit breaker

P/N THQL32080  
P/N THQL32015  
P/N THQL2115  
P/N THQL2130  
P/N THQL32060

Warning tags, Item 1, Appendix C

#### Equipment Condition

Power to emergency generator  
switchboard OFF, locked out,  
and tagged "Out of Service - Do  
Not Operate."

All switchboard circuit breakers OFF.

---

### WARNING

Electrocution, serious injury, or equipment damage can result from contact with live electrical circuits. Before beginning work on electrical systems, ensure electrical power is OFF, locked out and tagged to prevent turn on during maintenance.

### DISASSEMBLY

- a. Turn door panel screws (3, FIGURE 2-225) counterclockwise to loosen
- b. Remove door panel (17) using hand rail (2). Store panel door (17) in safe and out-of-way place.
- c. Open circuit breaker panel cover (4).

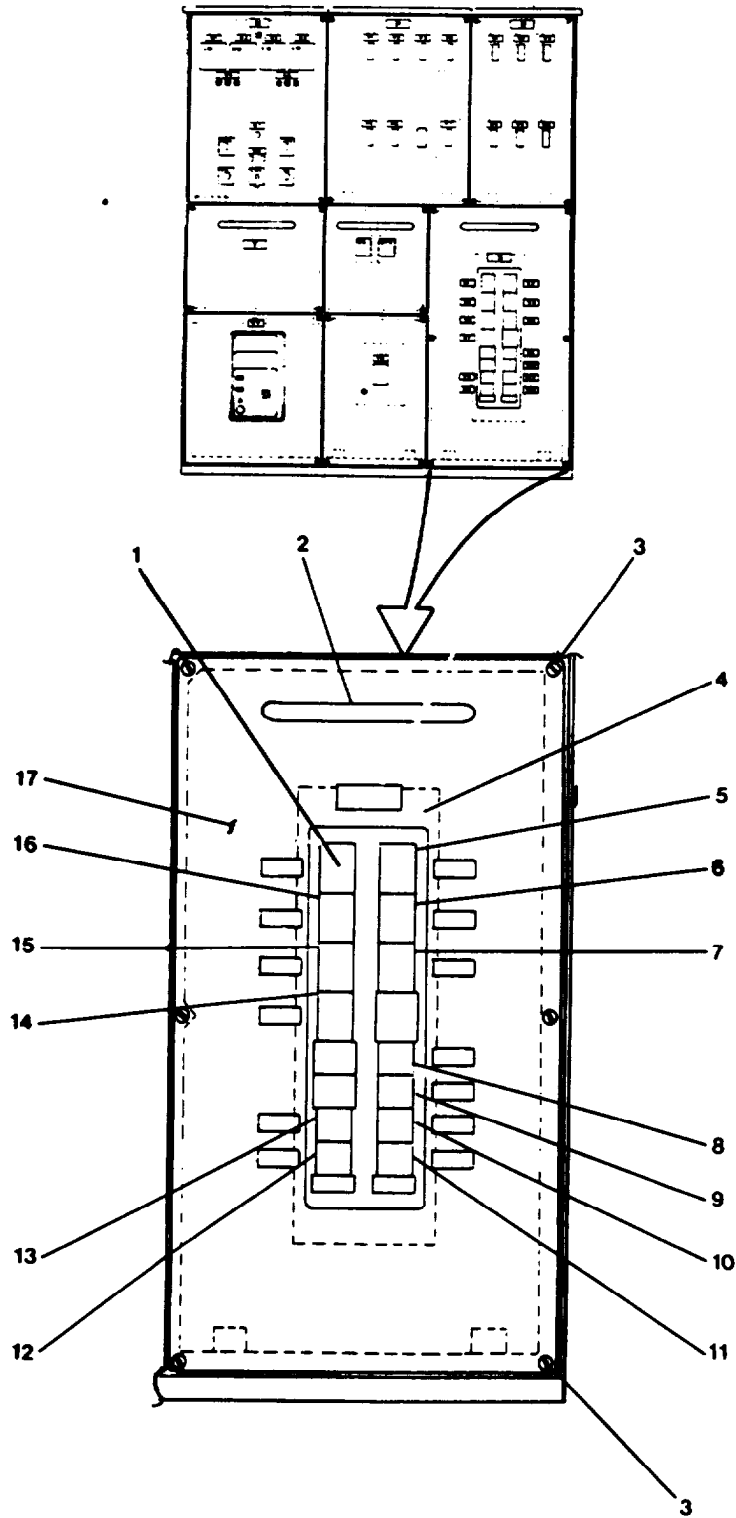


FIGURE 2-225. Emergency Generator Switchboard Bottom Right Panel.

**NOTE**

Circuit breakers are the plug-in type.

- d. Remove circuit breakers (1, and 5 through 16) by pulling straight out.

**REPAIR**

Repair to circuit breakers is by replacement of circuit breakers.

**ASSEMBLY**

- a. Install circuit breakers (1, and 5 through 16) by plugging straight in.
- b. Close circuit breaker panel door (4).
- c. Install door panel (17).
- d. Turn door panel screws (3) clockwise until tight.

**TEST**

Refer to paragraph 2-298.

---

**2-304. Repair Emergency Generator Switchboard Fuse Panel. (FIGURE 2-226)**

---

This task covers: a. Disassembly, b. Repair, c. Assembly.

---

**INITIAL SETUP****Tools**

Tool kit, electrician's,  
5180-00-391-1087

**Materials/Parts**

Cartridge fuses P/N BAF-15,  
P/N BAF-6, P/N BAF-3  
Voltage transformer P/N 460R-240  
Power transformer P/N B050BTZ13,  
P/N B100BTZ13  
Current transformer P/N 74R-201  
Under voltage relay P/N BE4-27-3AIN2  
Under frequency relay P/N BE4-81U-1A4N1  
Warning tags, Item 1, Appendix C

**Equipment Condition**

Power to emergency generator  
switchboard OFF, locked out,  
and tagged "Out of Service - Do  
Not Operate."  
All switchboard circuit breakers OFF.

---

**WARNING**

Electrocution, serious injury, or equipment damage can result from contact with live electrical circuits. Before beginning work on electrical systems, ensure electrical power is OFF, locked out and tagged to prevent turn on during maintenance.

**ASSEMBLY**

- a. Remove bolt-on flat sheet (1).
- b. Tag and disconnect wiring to transformer (7). Remove associated hardware and transformer (7).
- c. Open door panel (2). Refer to paragraph 2-293.
- d. Remove fuse cartridges from block fuseholders (3).
- e. Tag and disconnect wiring to block fuseholders (3).
- f. Remove associated hardware and block fuseholders (3).

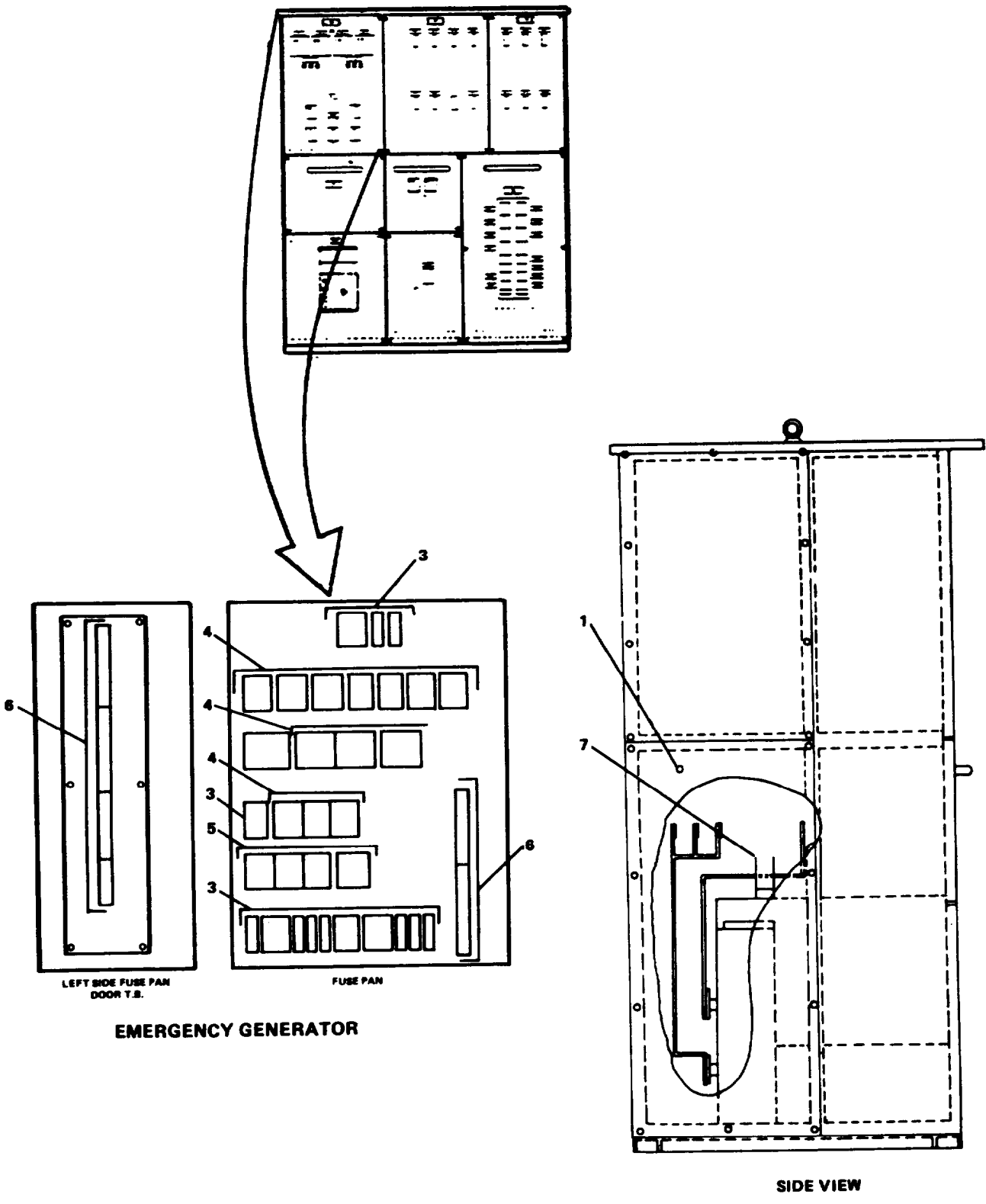


FIGURE 2-226. Emergency Generator Switchboard Fuse Panel.

- g. Tag and disconnect wiring to transformers (4).
- h. Remove associated hardware and transformers (4).
- i. Tag and disconnect wiring to relays (5).
- j. Remove associated hardware and relays (5).
- k. Tag and disconnect wiring to terminal boards (6).
- l. Remove associated hardware and terminal boards (6).

### REPAIR

Repair is by replacement of fuse cartridges, block fuseholders, transformers, and relays.

### ASSEMBLY

- a. Install transformer (7) with associated hardware.
- b. Connect wiring to transformer (7) and remove tags.
- c. Install block fuseholders with associated hardware.
- d. Connect wiring to block fuseholders (3) and remove tags.
- e. Install cartridge fuses into fuseholder.
- f. Install transformers (4) with associated hardware.
- g. Connect wiring to transformers (4) and remove tags.
- h. Install relays (5) with associated hardware.
- i. Connect wiring to relays (5) and remove tags.
- j. Install terminal boards (6) with associated hardware.
- k. Connect wiring to terminal boards (6) and remove tags.
- l. Close panel door (2) and secure.
- m. Install bolt-on flat sheet 1.
- n. Turn ON electrical power to emergency generator switchboard and remove tags.
- o. Turn ON all circuit breakers.

### TEST

Refer to paragraph 2-298.

MAINTENANCE OF PROPELLER SHAFT ASSEMBLY
---

---

**2-305. Inspect/Test Propeller Shaft Assembly.**

---

This task covers: a. Inspection, b. Test.

---

**INITIAL SETUP**

**Tools**

Tool kit, general mechanic's,  
5180-00-699-5273  
Torque wrench kit, 3377216

**Materials/Parts**

Warning tags, Item 1, Appendix C

**Equipment Condition**

Main propulsion engines (port and starboard) shut down. Refer to TN 55-1905-223-10.  
Starting air and control air valves to main propulsion engines (port and starboard) closed and tagged "Out of Service - Do Not Operate."

---

**INSPECTION**

- a. Close starting air and control air valves for main propulsion engines (port and starboard) and tag "Out of Service - Do Not Operate."
- b. Visually inspect the port and starboard propeller shaft (1, FIGURE 2-227) inside the vessel hull for straightness or structural cracks. If the propeller shaft is found to be bent or have structural cracks, maintenance by shipyard facility is required. Notify your supervisor.
- c. Visually inspect the port and starboard expander tube brake (2) as follows:
  - (1) Check for obvious defects on the brake drum (1, FIGURE 2-228) surface such as grooves or worn areas.
  - (2) Check socket head capscrews (8), lockwashers (7) and hexagon nuts (6) securing brake element support brackets (3) to brake mounting support brackets (4) for security. If loose, use a torque wrench and tighten bolts to 600 ft-lb torque.
  - (3) Check the brake elements (2) for obvious defects such as loose or broken parts. If loose or broken parts are observed, repair brake elements in accordance with paragraph 3-174.



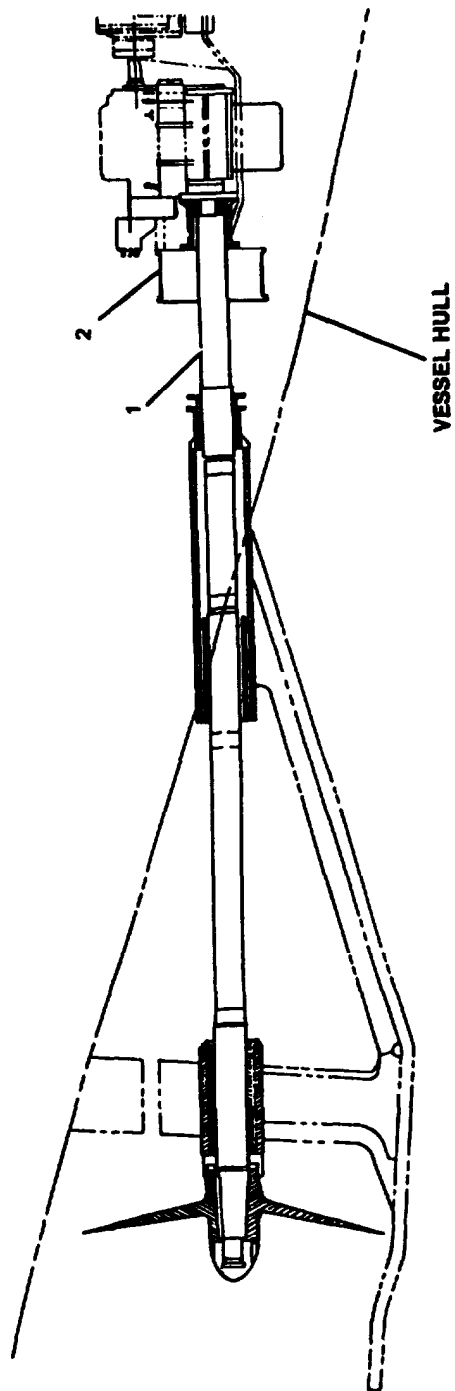


FIGURE 2-227. Propeller Shaft Assembly.

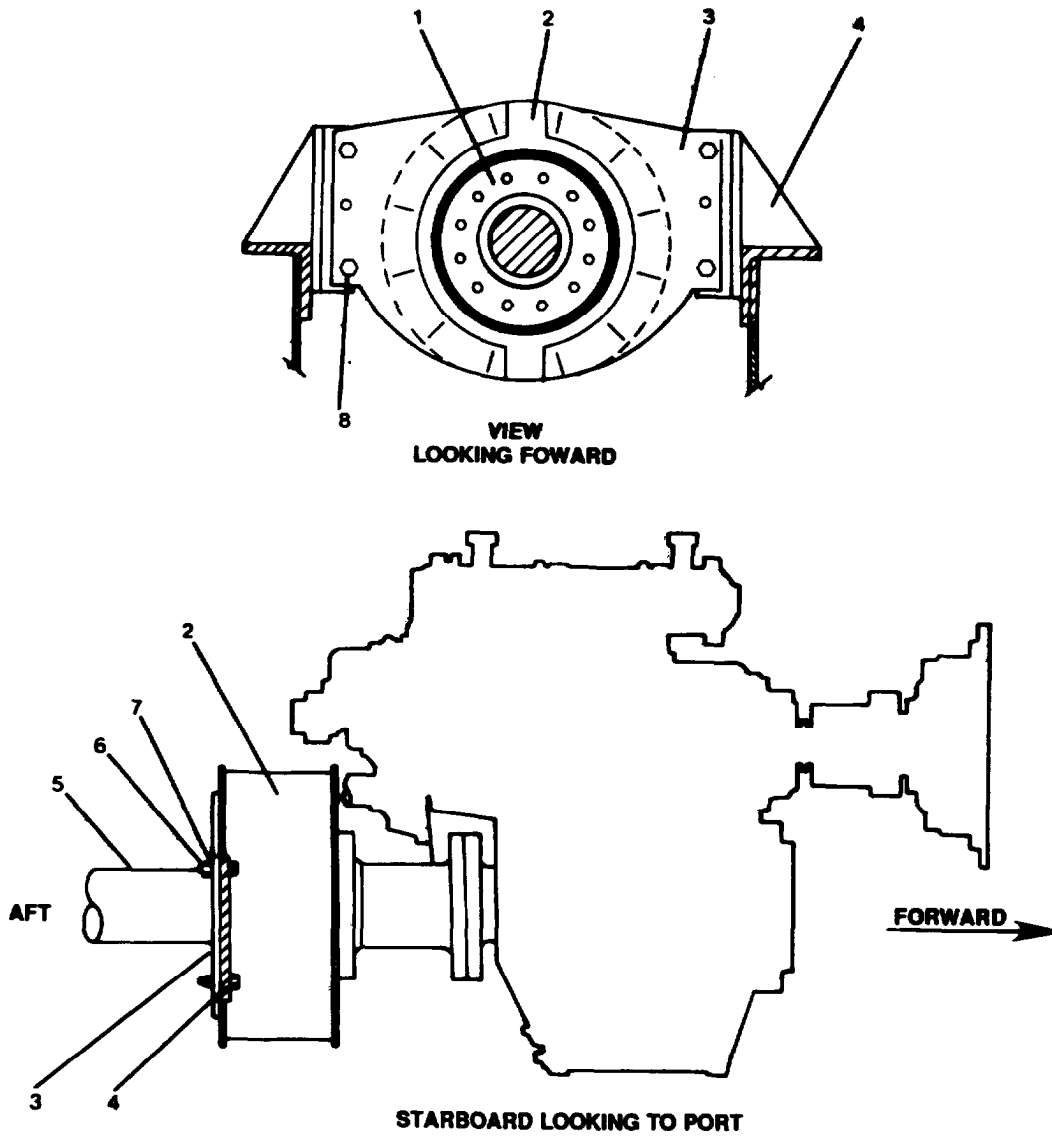


FIGURE 2-228. Expander Tube Brake.

- d. Visually inspect the electrical self generating shaft tachometers (FIGURE 2-229) as follows:
- (1) Check pickup sensing lug (2) on port and starboard propeller shaft flange (1) for looseness. Tighten screw set inside of pickup sensing lug (2) with screwdriver if loose.
  - (2) Check pickup mounting brackets (3) for looseness. Tighten pickup mounting bracket screws with screwdriver if loose.
  - (3) Check motional pickup transducers (5) for security in pickup mounting brackets (3). Tighten jam nuts (6) if loose.
  - (4) Check connector assembly with cable (4) for tightness. Hand tighten connector assembly with cable (4) to motional pickup transducer (5).
  - (5) Open starting air and control air valves for main propulsion engines (port and starboard). Remove "Out of Service, Do Not Operate" tags.

**TEST**

Perform operational test of the propeller shaft assembly prior to mission. Refer to TM 55-1905-223-10.

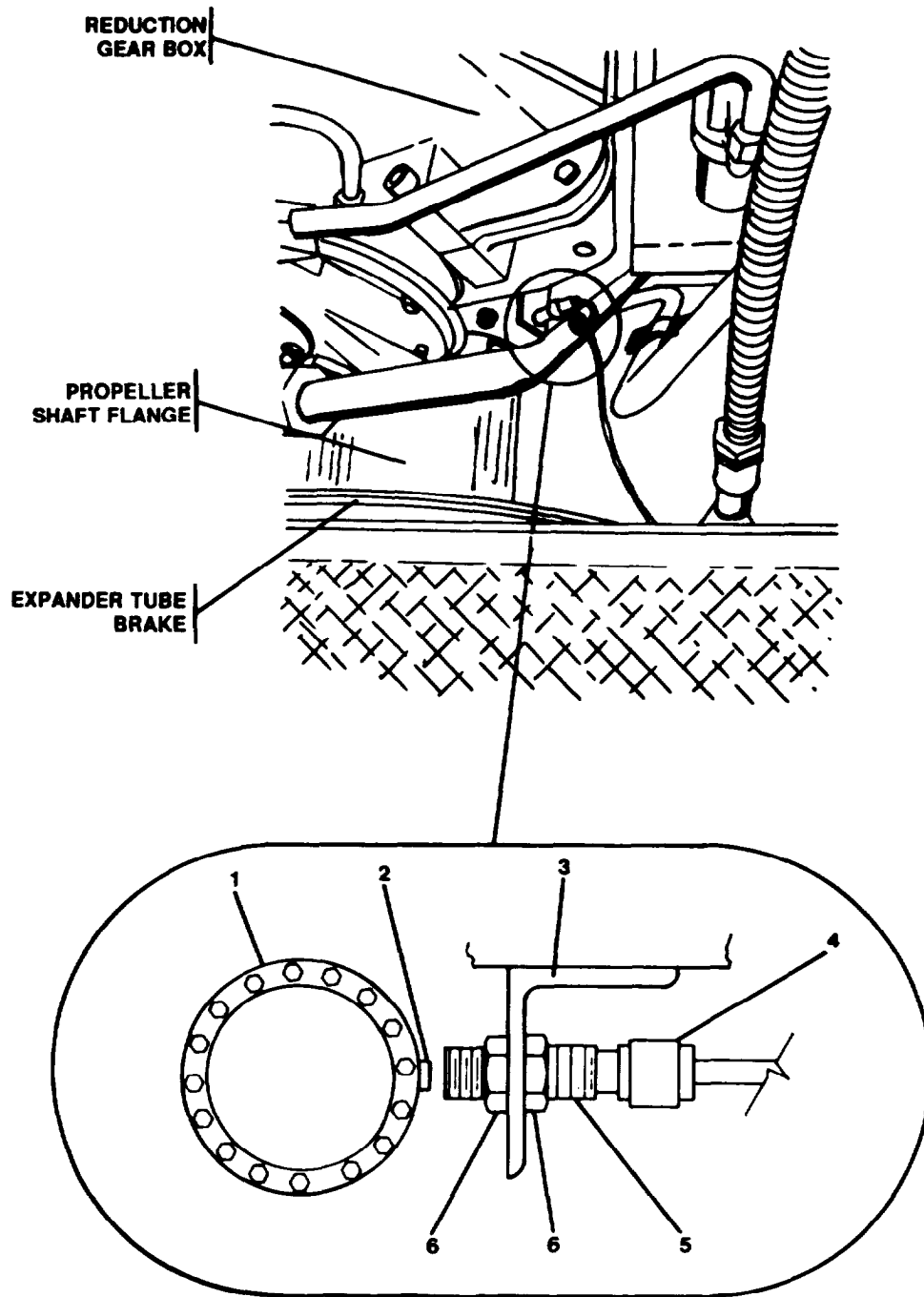


FIGURE 2-229. Electrical Self Generatine (Shaft) Tachometey.

---

## 2-306. Adjust Electrical Self Generating Shaft Tachometer.

---

This task covers: Adjustment.

---

### INITIAL SETUP

#### Tools

Tool kit, general mechanic's,  
5180-00-699-5273

#### Materials/Parts

Warning tags, Item 1, Appendix C

#### Equipment Condition

Main propulsion engines (port and starboard) shut down. Refer to TM 55-1905-223-10.

Starting air and control air valves to main propulsion engines (port and starboard) closed and tagged "Out of Service - Do Not Operate." Refer to TM 55-1905-223-10.

---

### ADJUSTMENT

The motional pickup transducer (5, FIGURE 2-230) contains flat spots (4) that must be oriented parallel to the propeller shaft flange (1) in order to transmit a direction/speed signal to shaft tachometer ammeters on the pilothouse and engine control station consoles.

#### WARNING

Main propulsion engines must be shutdown to perform the following steps to prevent injury to personnel.

- a. Using machine rule, measure gap distance between pickup sensing lug (2) on propeller shaft flange (1) and motional pickup transducer (5). Record this measurement for reference when securing motional pickup transducer.
- b. Loosen jam nuts (6) securing motional pickup transducer (5) to mounting bracket (3).
- c. If both shaft tachometer ammeters on pilothouse and engine control station consoles indicate opposite direction (AHEAD or ASTERN) from the direction of main propulsion shaft, rotate motional pickup transducer (5) 180° in mounting bracket (3) so that flat spots (4) on motional pickup transducer (5) are now oriented opposite what they were before.
- d. If both shaft tachometer ammeters on pilothouse and engine control station consoles do not indicate direction/speed of main propulsion shaft, orient motional pickup transducer (5) in mounting bracket (3) so that flat spots (4) are parallel to propeller shaft flange (1).

- e. Ensure gap distance between pickup sensing lug (2) propeller shaft flange (1) is exactly the same as that recorded in step a.
- f. Secure motional pickup transducer (5) in mounting bracket (3) with jam nuts (6).
- g. Request pilothouse to operate main propulsion engines in AHEAD and ASTERN and verify that shaft tachometer ammeters on pilothouse and engine control station consoles indicate correct direction.
- h. Remove "Out of Service - Do Not Operate" tags.

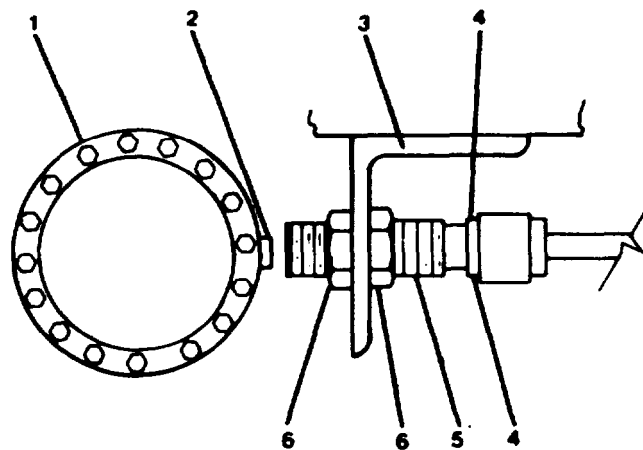


FIGURE 2-230. Adjusting Electrical Self-Generating Shaft Tachometer.

---

## 2-307. Repair Electrical Self Generating Shaft Tachometer.

---

This task covers: a. Disassembly, b. Repair, c. Assembly.

---

### INITIAL SETUP

#### **Tools**

Tool kit, general mechanic's,  
5180-00-699-5273  
Fuse puller, 5120-00-224-9453

#### **Materials/Parts**

Motional pickup transducer  
P/N M917  
Rheostat P/N R5303  
Arbitrary scale meter P/N DB1701  
(illuminated)  
Arbitrary scale meter P/N DB1802  
Warning tags, Item 1, Appendix C

#### **Equipment Condition**

Appropriate main propulsion engine  
shut down. Refer to TM 55-1905-223-  
10.  
Main propulsion engine tagged "Out of  
Service - Do Not Operate."  
Starting air and control air valves to  
main propulsion engine closed and  
tagged "Out of Service - Do Not  
Operate." TM 55-1905-223-10.

### **WARNING**

Appropriate main engine must be shut down,  
to prevent serious injury, before performing  
the following steps.

### **DISASSEMBLY**

- a. Remove motional pickup transducer.

### **WARNING**

ENGINE RM DC PNL EP024 contains 24 vdc. To  
prevent injury or damage to equipment, use  
extreme caution when removing cartridge  
fuses.

- (1) On ENGINE RM DC PNL EP024, use fuse puller and remove appropriate fuse cartridge #13, SFT TACH (STBD) or #14, SFT TACH (port) to remove 24 Vdc power from shaft tachometer circuit.
- (2) Disconnect connector assembly with cable (4, FIGURE 2-231) from motional pickup transducer (5).

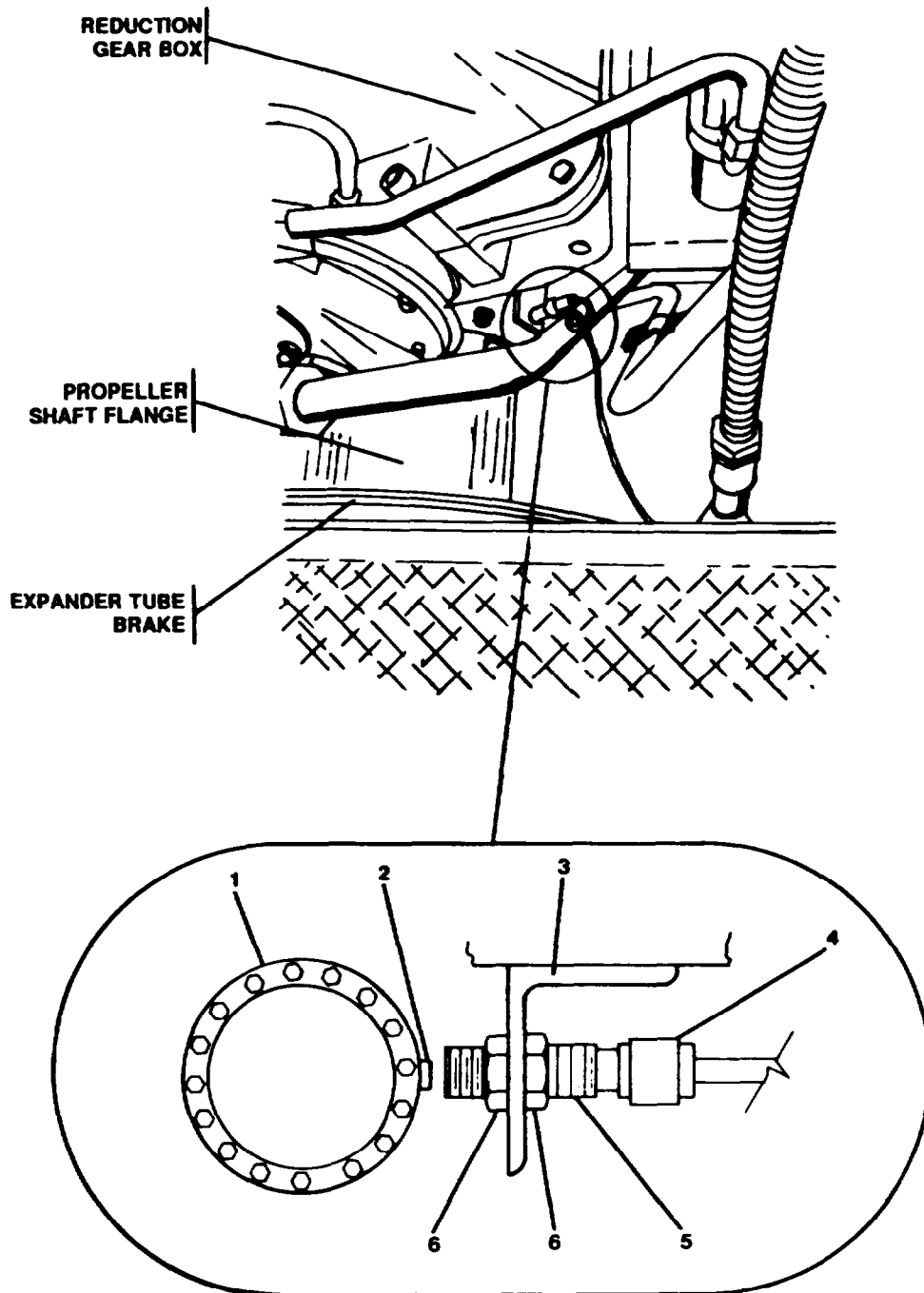


FIGURE 2-231. Motional Pickup Transducer.



- (3) Using machine rule, measure and record gap distance between pickup sensing lug (2) on shaft flange (1) and end of motional pickup transducer (5). This measurement will be used to install replacement motional pickup transducer.
  - (4) Loosen jam nuts (6) and remove motional pickup transducer (5) and jam nuts (6) from pickup mounting bracket (3).
- b. Remove arbitrary scale meter (2, FIGURE 2-232) (wheelhouse panel).

**WARNING**

ENGINE RM DC PNL EP024 contains 24 Vdc. To prevent injury to personnel or damage to equipment, use extreme caution when removing cartridge fuses.

- (1) On ENGINE RM DC PNL EP024, use fuse puller and remove appropriate fuse cartridge #13, SFT TACH (STBD) or #14, SFT TACH (port) to remove 24 Vdc power from shaft tachometer circuit.
  - (2) Turn off 24 VDC SUPPLY to dimmer rheostat (7).
  - (3) On wheelhouse console, gain access to bottom of console and tag and disconnect wiring from meter terminals (5, 6, 8 and 9) on arbitrary scale meter (10).
  - (4) Remove mounting screws (1 and 3) from top of console on appropriate meter (2) and mounting hardware from bottom of console.
  - (5) Remove appropriate meter (2) from console.
- c. Remove dimmer rheostat (7) (wheelhouse console).

**WARNING**

ENGINE RM DC PNL EP024 contains 24 Vdc. To prevent injury to personnel or damage to equipment, use extreme caution when removing fuse cartridges.

- (1) On ENGINE RM DC PNL EP024, use fuse puller and remove appropriate fuse cartridge #13, SFT TCH (STBD) or #14, SFT TACH (port) to remove 24 Vdc from port or starboard shaft tachometer circuit.
- (2) Turn off 24 VDC SUPPLY to dimmer rheostat (7).
- (3) On wheelhouse console, gain access to bottom of console and tag and disconnect wiring from appropriate dimmer rheostat (7).
- (4) Remove any mounting hardware and remove appropriate dimmer rheostat (7) from console.

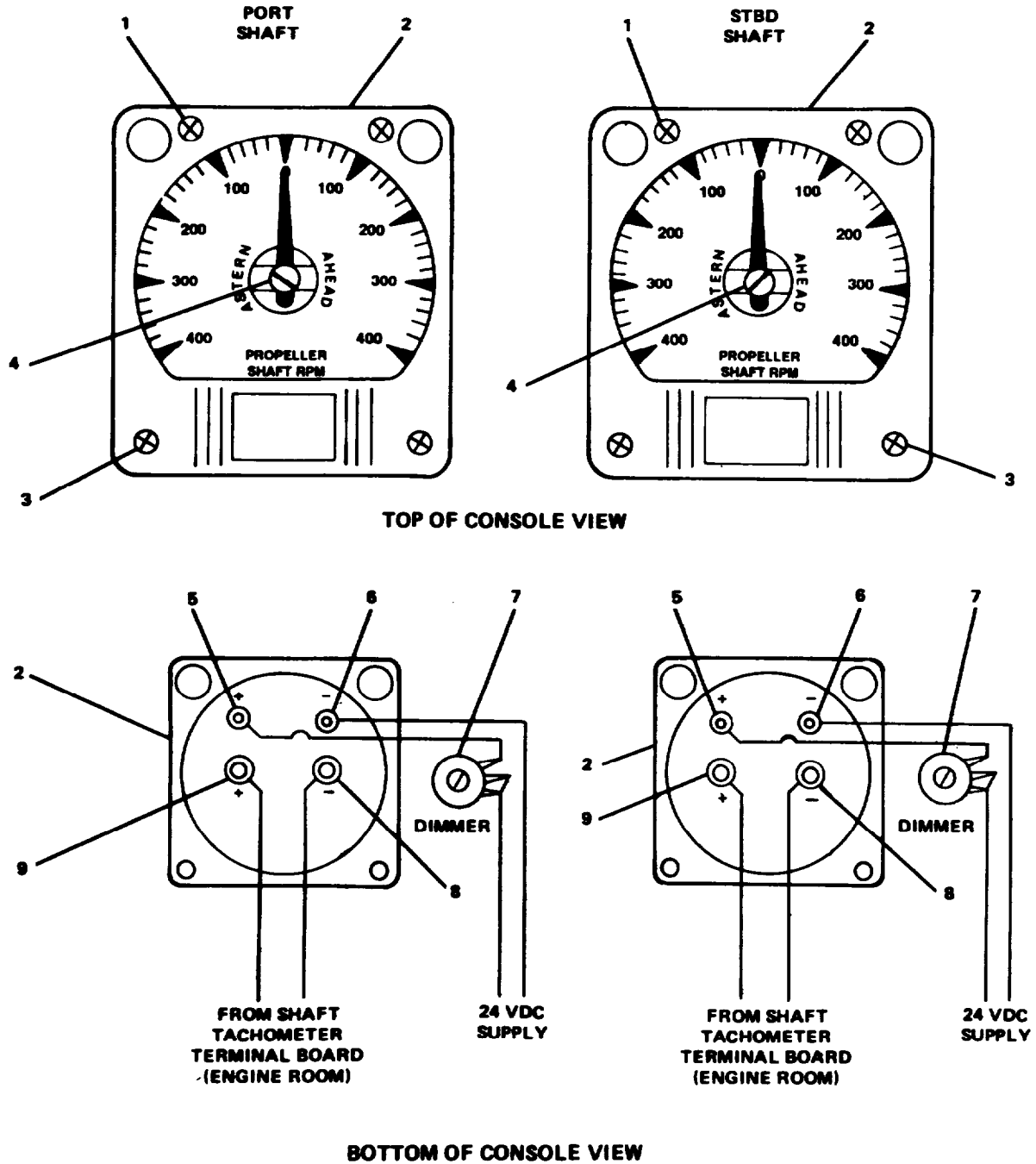


FIGURE 2-232. Wheelhouse Console Shaft Tachometers.

- d. Remove arbitrary scale meter (engine control station console).

**WARNING**

**ENGINE RM RC PNL EP024 contains 24 Vdc. To prevent injury to personnel and damage to equipment, use extreme caution when removing fuse cartridges.**

- (1) On ENGINE RM DC PNL EP024, use fuse puller and remove appropriate fuse cartridge #13, SFT TACH (STBD) or #14, SFT TACH (port) to remove 24 Vdc from port or starboard shaft tachometer circuit.
- (2) On engine control station console, gain access to bottom of console and tag and disconnect wiring from appropriate arbitrary scale meter (6, FIGURE 2-219) terminals (5 and 7).
- (3) On top of console, remove mounting screws (1) and mounting hardware from bottom of console and remove appropriate arbitrary scale meter (2) from console.

**REPAIR**

Repair of the electrical self generating tachometer is by replacing motional pickup transducer (5, FIGURE 2-232), dimmer rheostat (7, FIGURE 2-232) and arbitrary scale meter (2, FIGURE 2-232) or (2, FIGURE 2-233).

**ASSEMBLY**

- a. Install motional pickup transducer.
- (1) Position replacement motional pickup transducer (5, FIGURE 2-231) with jam nuts (6) in pickup mounting bracket (3).
  - (2) Using machine rule, measure and position motional pickup transducer (5) to gap measurement between pickup sensing lug (2) on shaft flange (1) and end of motional pickup transducer (5) recorded in DISASSEMBLY step a.(3). Secure jam nuts (6) ensuring gap distance is not disturbed.
  - (3) Connect connector assembly with cable (4) to motional pickup transducer.

**WARNING**

**ENGINE RM DC PNL EP024 contains 24 Vdc. To prevent injury to personnel and damage to equipment, use fuse puller to install fuse cartridge.**

- (4) On ENGINE RM DC PANEL EP024, use fuse puller and install appropriate fuse cartridge #14, SFT TACH (port) or #13, SFT TACH (STBD).
- (5) Adjust motional pick transducer (5).

- b. Install arbitrary scale meter (engine control station console).
  - (1) Position arbitrary scale meter (2, FIGURE 2-233) in engine control station console and secure with top mounting screws (1) and bottom mounting hardware.
  - (2) Calibrate meter (2) by using screwdriver at point (3) on top of meter and aligning meter needle to the straight up position.
  - (3) On bottom of console, connect wiring to terminals (5 and 7) on appropriate arbitrary scale meter (6). Remove tags.

**WARNING**

**ENGINE RM DC PNL EP024 contains 24 Vdc. To prevent injury to personnel and damage to equipment, use extreme care when replacing fuse cartridges.**

- (4) On ENGINE RM DC PNL EP024, use fuse puller and install appropriate fuse cartridge in position #14, SFT TAC (Port) or #13, SFT TACH (STBD).
  - (5) Request operations to start main engine and engage shafts in AHEAD and ASTERN. Observe that shaft tachometer indicates correct direction.
- C. Install dimmer rheostat (wheelhouse console).

- (1) Position appropriate dimmer rheostat (7, FIGURE 2-232) in console and replace any mounting hardware removed.
- (2) Connect wiring to appropriate dimmer rheostat (7). Remove tags.
- (3) Turn on 24 Vdc Supply by replacing appropriate fuse cartridge removed previously.

**WARNING**

**ENGINE RM DC PNL EP024 contains 24 Vdc. To prevent injury to personnel and damage to equipment, use extreme care when installing fuse cartridge.**

- (4) On ENGINE RM DC PNL EP024, use fuse puller and install appropriate fuse cartridge #14, SFT TACH (port) or #13, SFT TACH (STBD).
  - (5) Using screwdriver, vary dimmer rheostat (7, FIGURE 2-232) and observe that appropriate arbitrary scale meter (2) illumination varies.
- d. Install arbitrary scale meter (wheel house console).

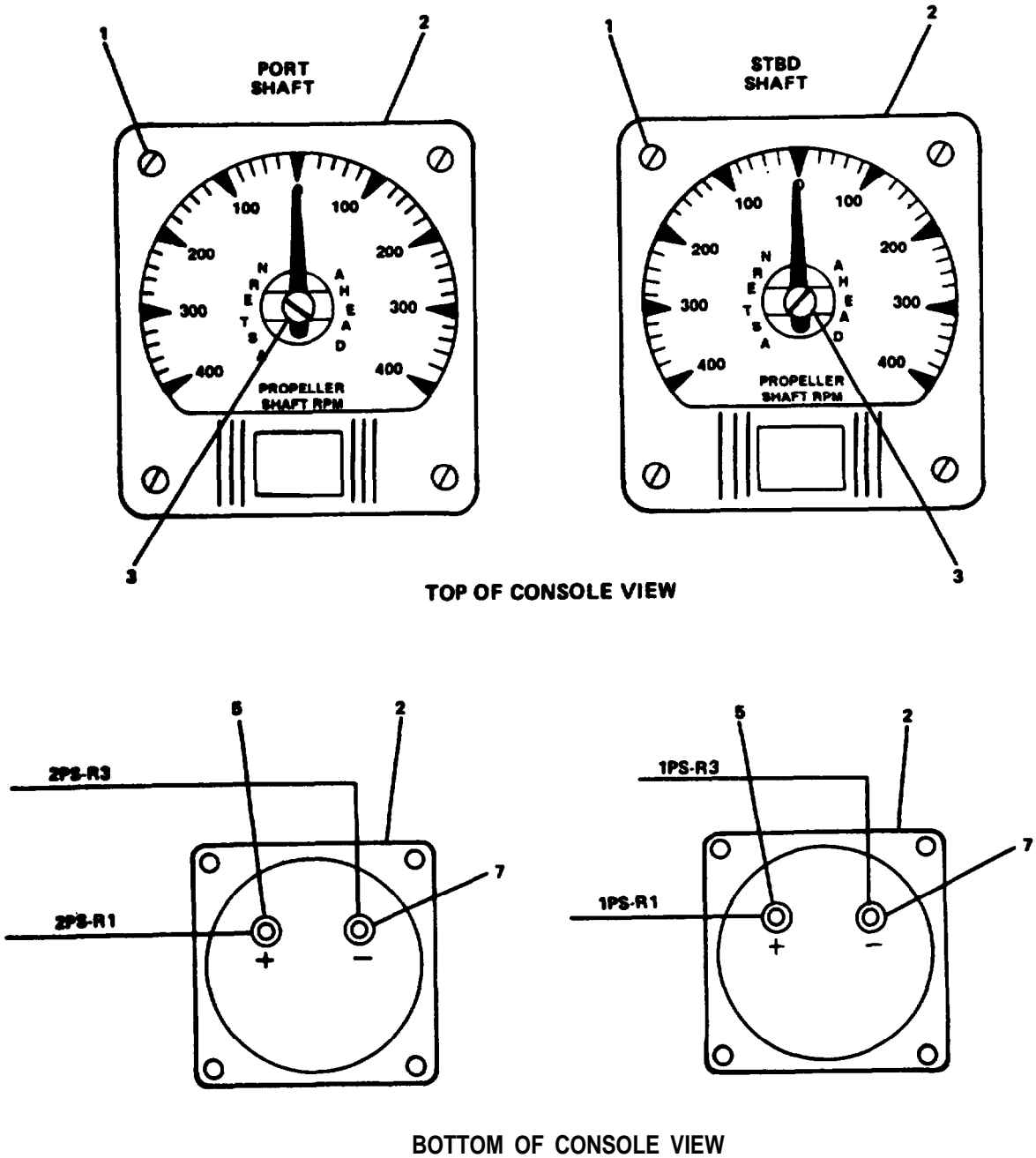


FIGURE 2-233. Engine Control Station Console Tachometers.

- (1) Position appropriate arbitrary scale meter (2, FIGURE 2-231) in wheelhouse console and secure with mounting screws (1 and 3) and mounting hardware on bottom of console.
- (2) From bottom of console, connect wiring to meter (2) terminals (5, 6, 8 and 9). Remove tags.
- (3) Turn on 24 Vdc supply to dimmer rheostats (7).

**WARNING**

**ENGINE RM DC PNL EP024 contains 24 Vdc. To prevent injury to personnel and damage to equipment, use fuse puller to install fuse cartridge.**

- (4) On ENGINE RM DC PNL EP024, using fuse puller, install appropriate fuse cartridge #14, SFT TACH (port) or #13, SFT TACH (STBD).
- (5) Request operations to start main engine and engage shaft in AHEAD and ASTERN, and observe arbitrary scale meter (2, FIGURE 2-231) for correct shaft direction indication.

MAINTENANCE OF VALVES/STRAINERS
---------------------------------

---

2-308. Replace/Repair 2-1/2-Inch Stop Check Angle Valve. (FIGURE 2-234)

---

This task covers: a. Removal, b. Repair, c. Replacement

---

### INITIAL SETUP

#### Tools

Tool kit, general mechanic's,  
5180-00-699-5273  
Portable welding equipment  
P/N 1341-0354

#### Equipment Condition

Piping system shut down.  
Valve isolated from system,  
reference TM 55-1905-223-10.

#### Materials/Parts

2-1/2-inch stop check angle valve  
P/N B-142-0000

---

### REMOVAL

- a. Place a drip pan under stop check angle valve.
- b. Use a welding torch to cut valve (1) at flanges (2, 3).
- c. Remove valve.
- d. File pipe edges smooth.

### REPAIR

Repair at this level of maintenance is by replacement of wheelnut and handwheel or replacement of the entire valve.

### REPLACEMENT

- a. Place stop check angle valve (1) at flanges (2, 3).
- b. Weld valve to flanges.
- c. Let valve cool before pressure check.
- d. Charge piping system and check for leaks.
- e. Remove drip pan.

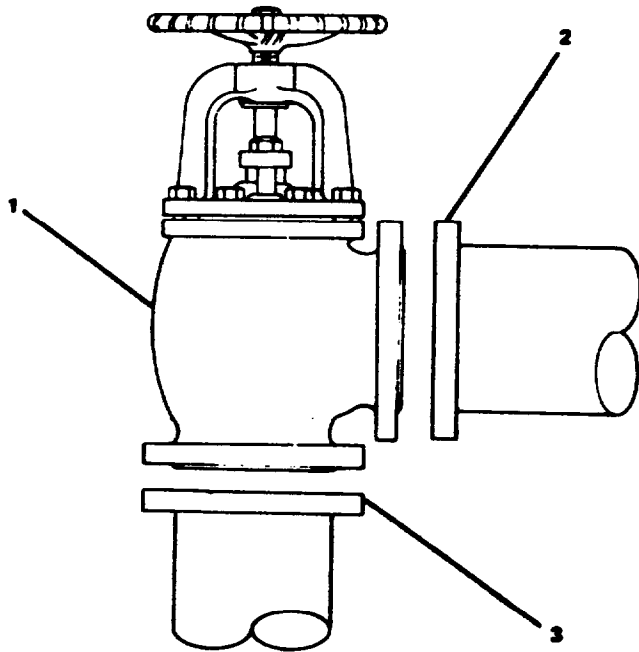


FIGURE 2-234. 2-1/2-Inch Stop Check Angle Valve.



---

2-309. Replace 4-Inch Three-Way Ball Valve. (FIGURE 2-235)

---

This task covers: a. Removal, b. Replacement.

---

### INITIAL SETUP

#### Tools

Tool kit, general mechanic's,  
5180-00-699-5273  
Torque wrench (30-300 ft-lb),  
5120-01-125-5190

#### Equipment Condition

Piping system shut down.  
Valve isolated from system,  
reference TM 55-1905-223-10.

#### Materials/Parts

4-inch three-way ball valve  
P/N MP-20-86165

---

### REMOVAL

- a. Place a drip pan under ball valve (1).
- b. Remove nuts (2) and bolts (3) from flanges.

#### **NOTE**

A chain hoist will be required to remove/  
replace ball valve.

- c. Remove ball valve.

### REPLACEMENT

#### **NOTE**

A chain hoist will be required to remove/  
replace ball valve.

- a. Install ball valve (1) and attach with bolts (3).
- b. Install nuts (2) and torque to 75 ft-lb (102 N•m).
- c. Charge pipeline and check for leaks.
- d. Remove drip pan.

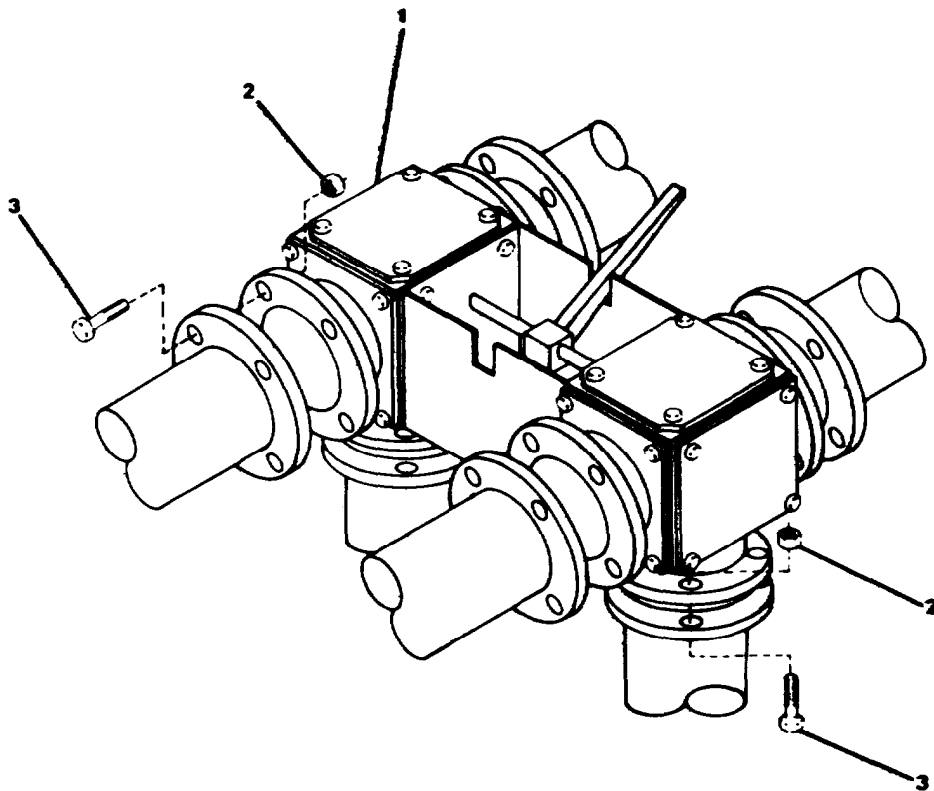


FIGURE 2-235. 4-Inch Three-Way Ball Valve, Replace.

---

2-310. Replace/Repair 4-Inch Three-Way Ball Valve. (FIGURE 2-236)

---

This task covers: a. Removal, b. Disassembly, c. Repair, d. Assembly, e. Replacement.

---

### INITIAL SETUP

#### Tools

Tool kit, general mechanic's,  
5180-00-699-5273  
Torque wrench (30-300 ft-lb),  
5120-01-125-5190

#### Equipment Condition

Piping system shut down.  
Valve isolated from system,  
reference TM 55-1905-223-10.

#### Materials/Parts

4-inch three-way ball valve  
P/N HP-20-F15 41N

---

### REMOVAL

- a. Place a drip pan under ball valve (4).
- b. Remove nuts (1) and bolts (2) from flanges (3).

#### NOTE

Two soldiers will be required to remove/  
replace ball valve.

- c. Remove ball valve (4).

### DISASSEMBLY

- a. Remove nut (5), washer (6), and valve handle (7).
- b. Remove packing retainer (8), gland liner (9), and packing retainer (10).

### REPAIR

Repair at this level of maintenance is replacement of worn or damaged parts or replacement of the entire valve.

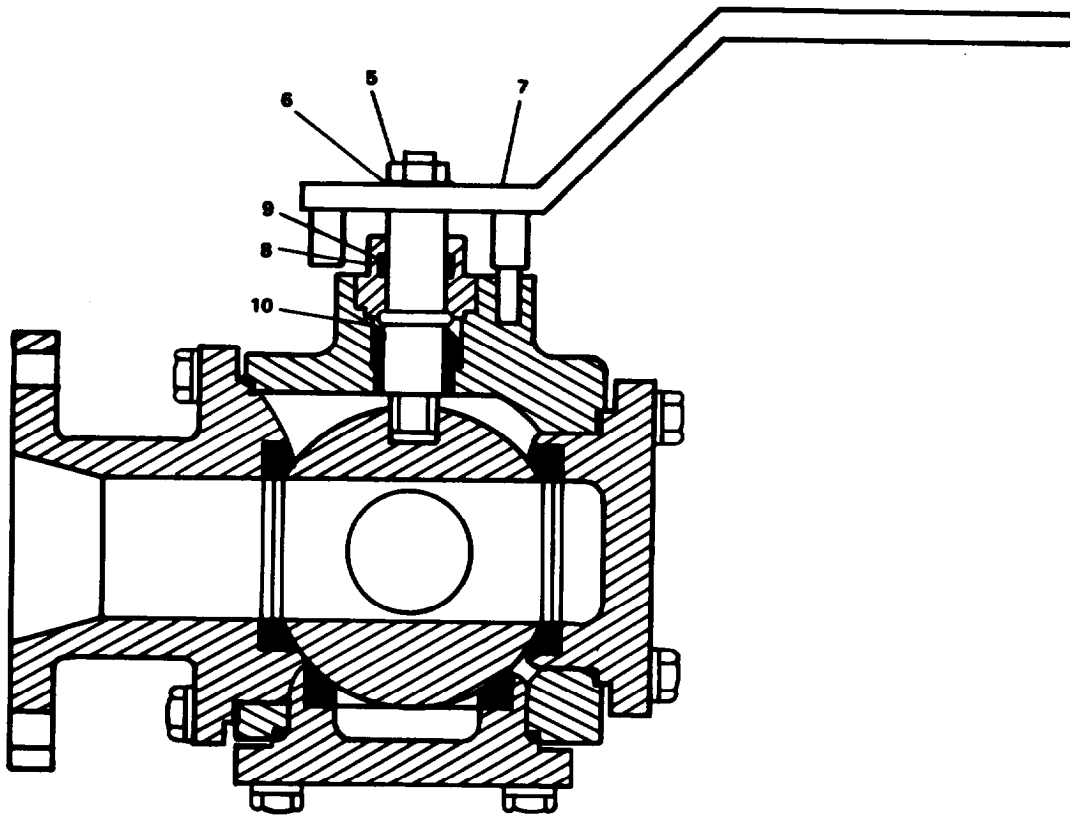
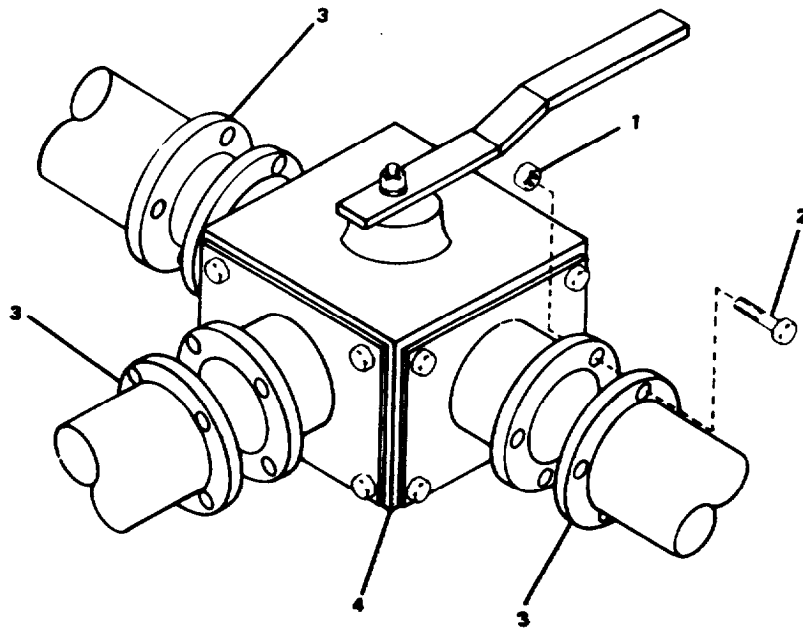


FIGURE 2-236. 4-Inch Three-Way Ball Valve, Repair.

**ASSEMBLY**

- a. Install packing retainer (10), gland liner (9), and packing retainer (8).
- b. Install valve handle (7), washer (6), and nut (5).

**REPLACEMENT**

**NOTE**

Two soldiers will be required to remove/  
replace ball valve.

- a. Install ball valve (4) and attach with bolts (2).
- b. Install nut (1) and torque to 75 ft-lb (102 N•m).
- c. Charge pipeline and check for leaks.
- d. Remove drip pan.

---

2-311. Replace 4-Inch Three-Way Ball Valve. (Refer to para. 2-310)

---

---

2-312. Replace 4-Inch Swing Check Valve. (FIGURE 2-237)

---

This task covers: a. Removal, b. Replacement.

---

**INITIAL SETUP**

**Tools**

Tool kit, general mechanic's,  
5180-00-699-5273  
Torque wrench (30-300 ft-lb),  
5120-01-125-5190

**Equipment Condition**

Piping system shut down.  
Valve isolated from system,  
reference TM 55-1905-223-10.

**Materials/Parts**

4-inch swing check valve  
P/N 5341F-41N

---

**REMOVAL**

- a. Place a drip pan under swing check valve (1).
- b. Remove nuts (2) and bolts (3) from flanges (4).

**NOTE**

Two soldiers will be required to remove/  
replace swing check valve.

- c. Remove swing check valve.

**REPLACEMENT**

**NOTE**

Two soldiers will be required to remove/  
replace swing check valve.

- a. Install swing check valve (1) and attach with bolts (3).
- b. Install nuts (2) and torque to 75 ft-lb (102 N•m).
- c. Charge pipeline and check for leaks.
- d. Remove drip pan.

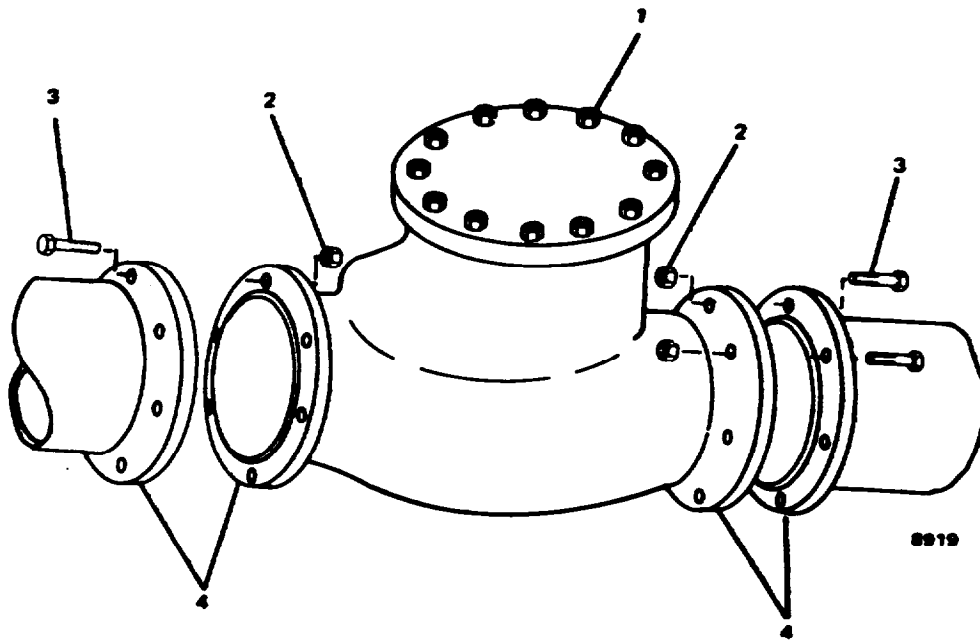


FIGURE 2-237. 4-Inch Swing Check Valve.



---

2-313. Replace/Repair 5-Inch Simplex Sediment Strainer. (FIGURE 2-236)

---

This task covers: a. Removal, b. Disassembly, c. Repair, d. Assembly, e. Replacement.

---

### INITIAL SETUP

#### Tools

Tool kit, general mechanic's,  
5180-00-699-5273  
Torque wrench (30-300 ft-lb),  
5120-01-125-5190  
Lifting sling P/N 3375958

#### Equipment Condition

Piping system shut down.  
Strainer isolated from system,  
reference TM 55-1905-223-10.

### Materials/Parts

5-inch simplex sediment strainer  
P/N ST0720500F6C  
Sediment strainer element  
P/N ST270SHXX  
Preformed packing P/N ST269Z5B

---

### REMOVAL

- a. Place a drip pan under simplex sediment strainer (3, FIGURE 2-238) and remove drain plug (4).
- b. Replace drain plug after draining strainer.
- c. Remove nuts (2) and bolts (1).
- d. Remove mounting bolts (5).

#### **NOTE**

The simplex sediment strainer is heavy and will require two soldiers or a chain hoist to remove.

### DISASSEMBLY

- a. Remove plain studs (2, FIGURE 2-239) from body (9).
- b. Remove yoke screw (3), yoke (1), and access cover (4).

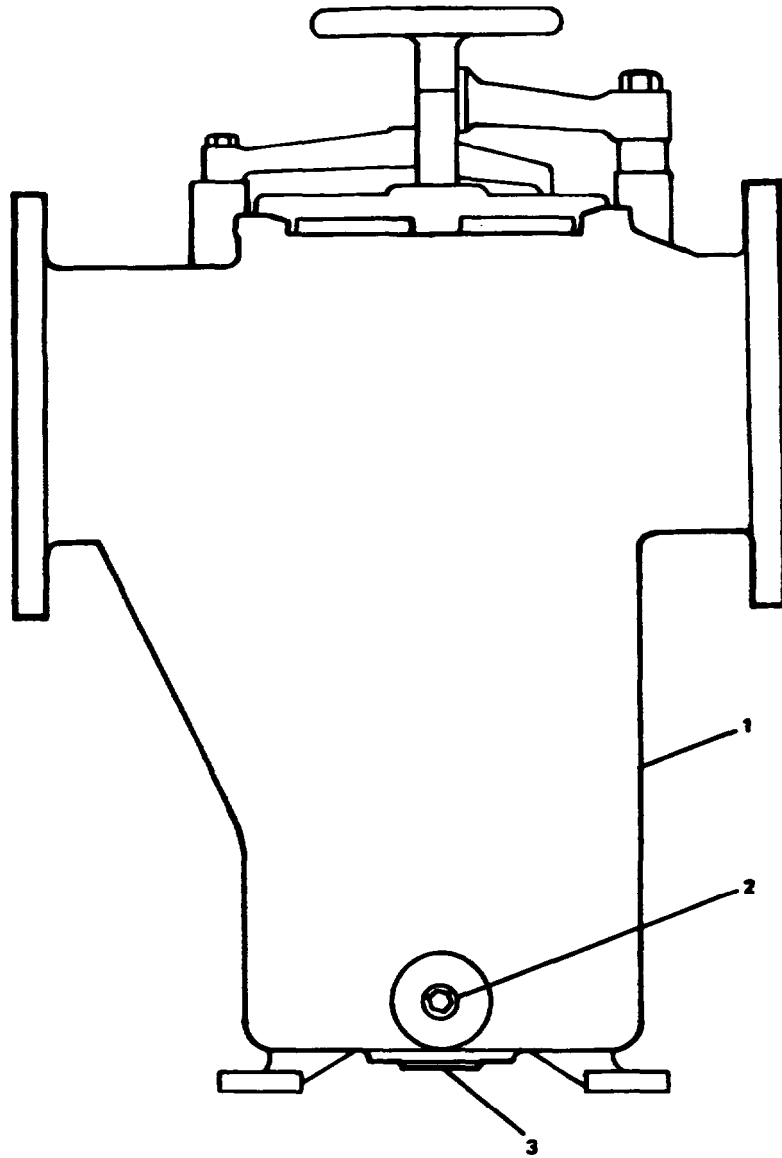


FIGURE 2-238. 5-Inch Simplex Sediment Strainer, Removal.

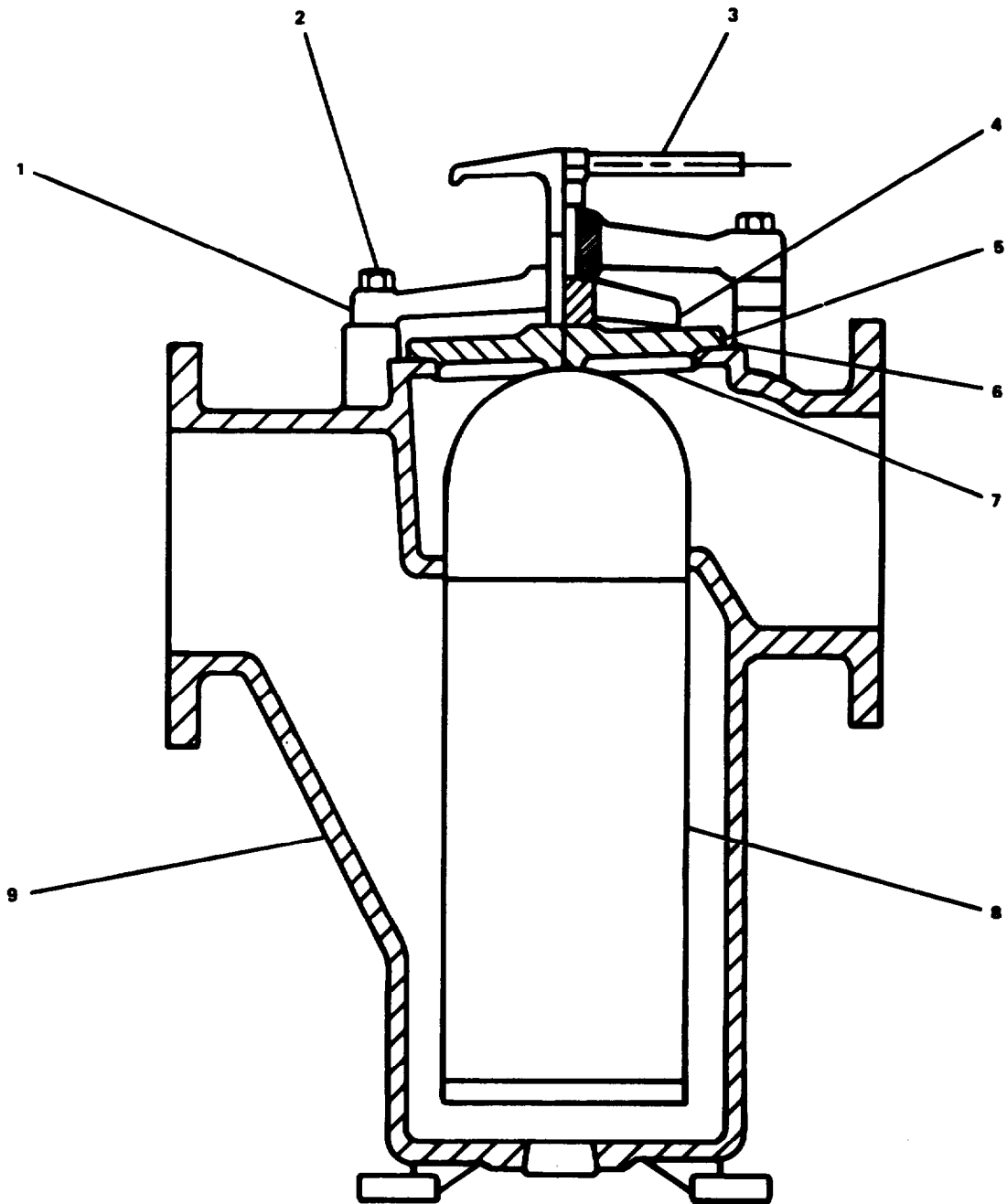


FIGURE 2-239. 5-Inch Simplex Sediment Strainer, Repair.

- c. Remove cover (5) and preformed packing (6).
- d. Remove spacer (7).
- e. Remove sediment strainer element (8).

**REPAIR**

Repair at this level of maintenance is by replacement of sediment strainer element (8), preformed packing (6) or entire assembly.

**ASSEMBLY**

- a. Install sediment strainer element (8, FIGURE 2-239) in body (9).
- b. Install spacer (7).
- c. Install preformed packing (6) and cover (5).
- d. Install access cover (4), yoke (1), and yoke screw (3).
- e. Install plain studs (2).

**REPLACEMENT**

**NOTE**

The simplex sediment strainer is heavy and will require two soldiers or a lift hoist to replace.

- a. Install simplex sediment strainer (3, FIGURE 2-238).
- b. Install mounting bolts (5) and torque to 75 ft-lb (102 N•m).
- c. Install bolts (1).
- d. Install nuts (2) and torque to 75 ft-lb (102 N•m).
- e. Charge the piping system and check for leaks. Remove drip pan.

---

**2-314. Replace/Repair S-Inch Simplex Sediment Strainer.**

---

This task covers: a. Removal, b. Disassembly, c. Repair, d. Assembly, e. Replacement.

---

**INITIAL SETUP****Tools**

Tool kit, general mechanic's,  
5180-00-699-5273  
Torque wrench (30-300 ft-lb),  
5120-01-125-5190

**Element Condition**

Piping system shut down.  
Strainer isolated from system,  
reference TM 55-1905-223-10.

**Materials/Parts**

8-inch simplex sediment strainer  
P/N 683  
Basket sediment strainer element  
P/N 26851-8-683-7  
Gasket P/N 26851-8-683-6

---

**REMOVAL**

- a. Place a drip pan under sediment strainer (3, FIGURE 2-240) and remove drain plug (4).
- b. Replace drain plug (4) after draining strainer.
- c. Remove flange nuts (2) and bolts (1).

**NOTE**

A chain hoist will be required to remove  
simplex sediment strainer.

- d. Remove simplex sediment strainer.

**DISASSEMBLY**

- a. Remove hexagon nuts (1, FIGURE 2-241) and cover (2).
- b. Remove cover gasket (4).
- c. Remove basket sediment strainer element (3).

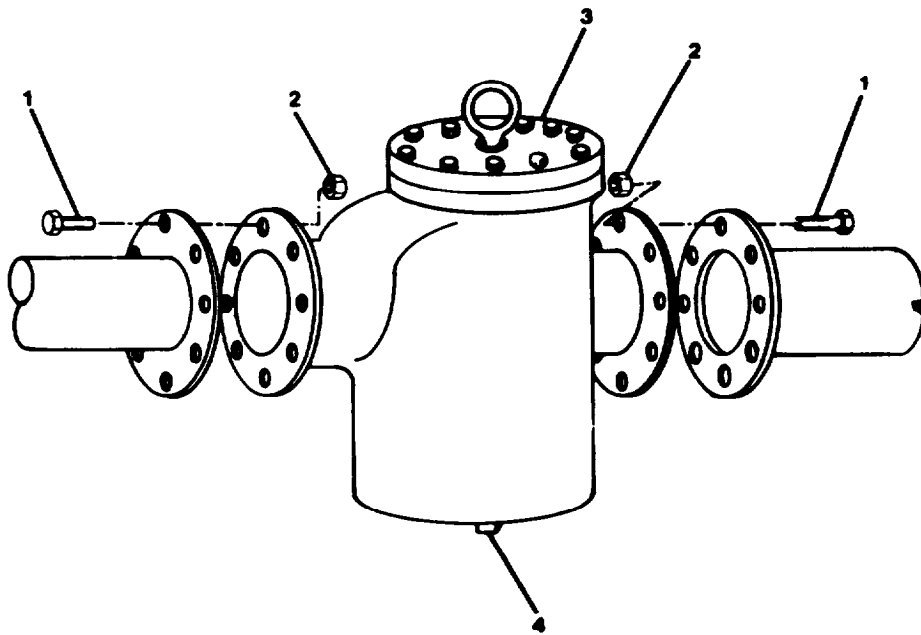


FIGURE 2-240. 8-Inch Simplex Sediment Strainer, Removal.

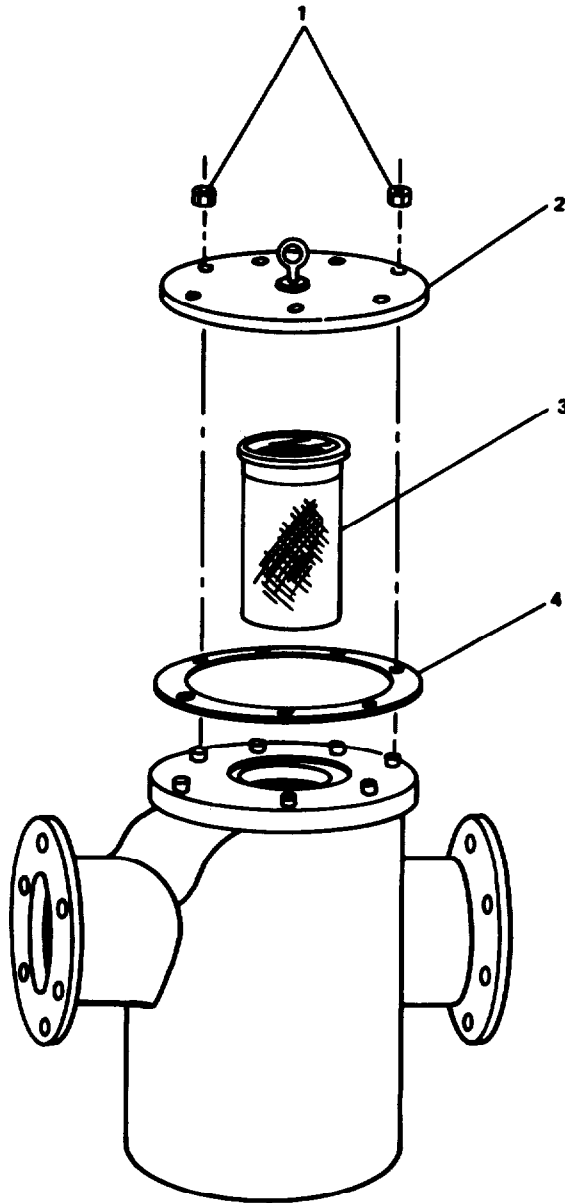


FIGURE 2-241. 8-Inch Simplex Sediment Strainer, Repair.

**REPAIR**

Repair at this level of maintenance is by replacement of basket sediment strainer element (3), gasket (4) or entire assembly.

**ASSEMBLY**

- a. Install basket sediment strainer (3, FIGURE 2-241).
- b. Install gasket (4) and cover (2).
- c. Install hexagon nuts (1) and torque to 75 ft-lb (102 N•m).

**REPLACEMENT**

**NOTE**

A chain hoist will be required to replace simplex sediment strainer.

- a. Install simplex sediment strainer (3, FIGURE 2-240).
- b. Install bolts (1), nuts (2) and torque to 75 ft-lb (102 N•m).
- c. Charge piping and check for leaks.
- d. Remove drip pan.



2-315. Replace/Repair 4-Inch Sediment Strainer Basket.

This task covers: a. Removal, b. Disassembly, c. Repair, d. Assembly, e. Replacement.

INITIAL SETUP

Tools

Tool kit, general mechanic's,  
5180-00-699-5273  
Torque wrench (30-300 ft-lb),  
5120-01-125-5190

Equipment Condition

Piping system shut down.  
Strainer isolated from system,  
reference TM 55-1905-223-10.

Materials/Parts

4-inch sediment strainer basket  
P/N AN-4.0-185-E3  
Sediment strainer element  
P/N BK-4.0-891S-4-1-A  
Gasket P/N TG-4.0-891S-8-0

REMOVAL

- a. Place a drip pan under sediment strainer basket (3, FIGURE 2-242) and remove drain plug (4).
- b. Replace drain plug (4) after draining strainer.
- c. Remove nuts (2) and bolts (1).

**NOTE**

Two soldiers will be required to remove sediment strainer basket.

- d. Remove sediment strainer basket.

DISASSEMBLY

- a. Remove hexagon nuts (1, FIGURE 2-243).
- b. Remove cover (2) and gasket (3).
- c. Remove strainer sediment element (4).

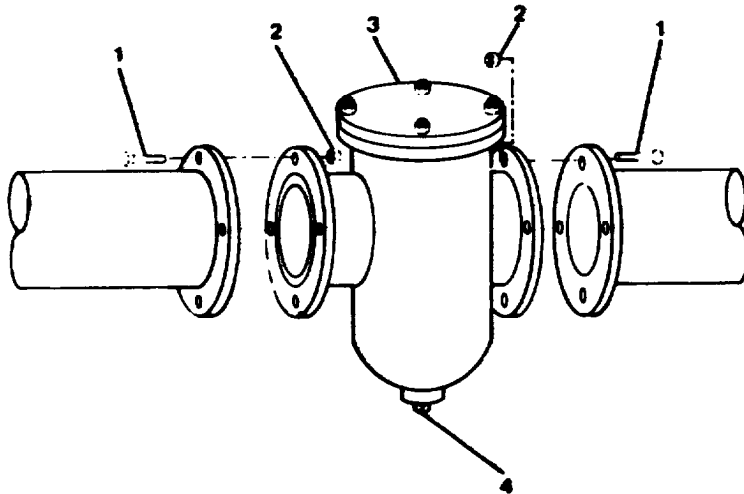


FIGURE 2-242. 4-Inch Sediment Strainer Basket, Removal.

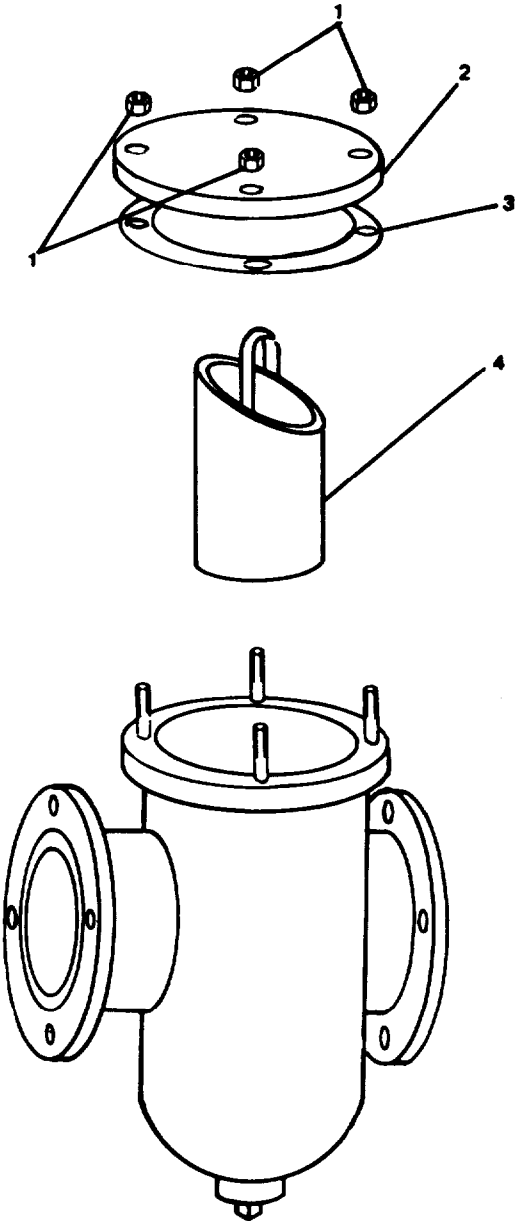


FIGURE 2-243. 4-Inch Sediment Strainer Basket, Repair.

**REPAIR**

Repair at this level of maintenance is by replacement of gasket (3), strainer sediment element (4) or entire assembly.

**ASSEMBLY**

- a. Install strainer sediment element (4) (FIGURE 2-243).
- b. Install gasket (3) and cover (2).
- c. Install hexagon nuts (1) and torque to 75 ft-lb (102 N•m).

**REPLACEMENT**

**NOTE**

Two soldiers will be required to replace sediment strainer basket.

- a. Install sediment strainer basket (3, FIGURE 2-242) and attach with bolts (1).
- b. Install nuts (2) and torque to 75 ft-lb (102 N•m).
- c. Charge pipeline and check for leaks.
- d. Remove drip pan.

---

2-316. Replace/Repair 5-Inch Sediment Strainer Basket.

---

This task covers: a. Removal, b. Disassembly, c. Repair, d. Assembly,  
e. Replacement.

---

### INITIAL SETUP

#### Tools

Tool kit, general mechanic's,  
5180-00-699-5273  
Torque wrench (30-300 ft-lb),  
5120-01-125-5190

#### Equipment Condition

Piping system shut down.  
Strainer isolated from system,  
reference TM 55-1905-223-10.

#### Materials/Parts

5-inch sediment strainer basket  
P/N AN-5.0-185-E3  
1/8" Perforated basket  
P/N MC-5.0-899S-4-1-A  
Asbestos gasket P/N TG-5.0-899S-B-0

---

### REMOVAL

- a. Place a drip pan under sediment strainer basket (3, FIGURE 2-244) and remove drain plug (4).
- b. Replace drain plug (4) after draining strainer.
- c. Remove nuts (2) and bolts (1).

#### NOTE

Two soldiers will be required to remove  
sediment strainer basket.

- d. Remove sediment strainer basket.

### DISASSEMBLY

- a. Remove hexagon nuts (1, FIGURE 2-245).
- b. Remove cover (2) and asbestos gasket (3).
- c. Remove strainer sediment element (4).

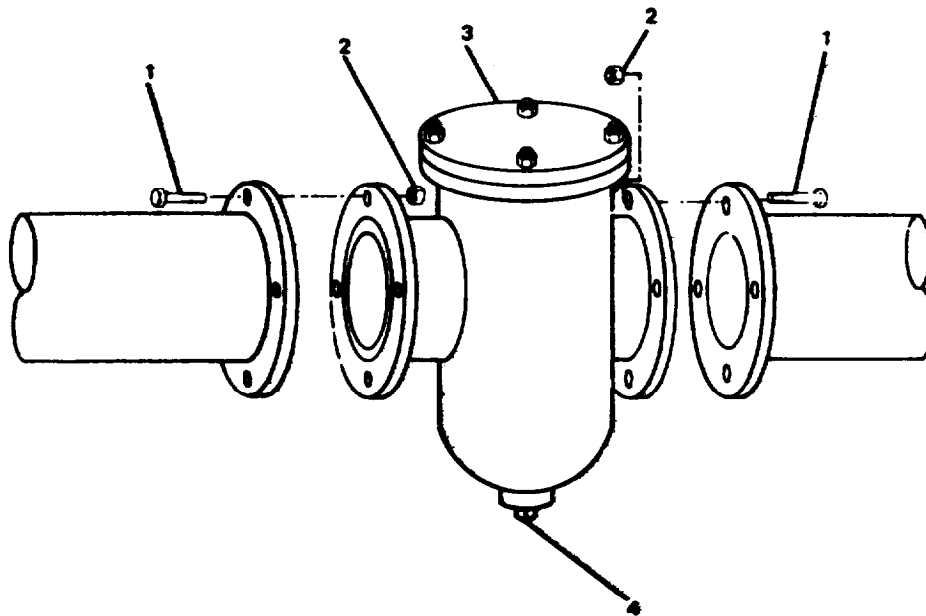


FIGURE 2-244. 5-Inch Sediment Strainer Basket, Removal.

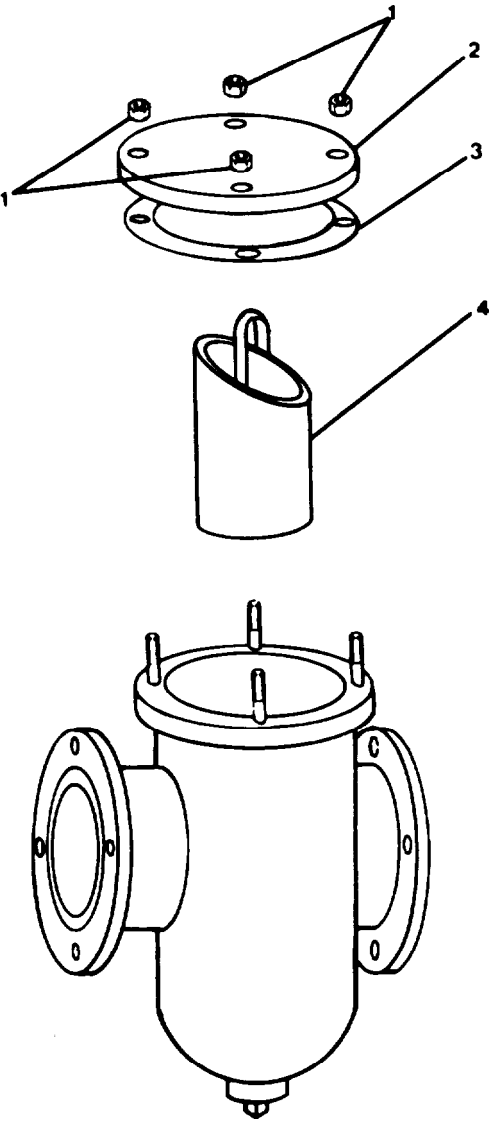


FIGURE 2-245. 5-Inch Sediment Strainer Basket, Repair.

**REPAIR**

Repair at this level of maintenance is by replacement of gasket (3), perforated gasket (4), or entire assembly.

**ASSEMBLY**

- a. Install strainer sediment element (4, FIGURE 2-245).
- b. Install asbestos gasket (3) and cover (2).
- c. Install hexagon nuts (1) and torque to 75 ft-lb (102 N•m).

**REPLACEMENT**

**NOTE**

Two soldiers will be required to replace sediment strainer basket.

- a. Install sediment strainer basket (3, FIGURE 2-244) and attach with bolts (1).
- b. Install nuts (2) and torque to 75 ft-lb (102 N•m).
- c. Charge pipeline and check for leaks.
- d. Remove drip pan.



---

2-317. Replace/Repair 2-1/2-Inch Sediment Strainer Basket.

---

This task covers: a. Removal, b. Disassembly, c. Repair, d. Assembly, e. Replacement.

---

### INITIAL SETUP

#### Tools

Tool kit, general mechanic's,  
5180-00-699-5273  
Torque wrench (30-300 ft-lb),  
5120-01-125-5190

#### Equipment Condition

Piping system shut down.  
Strainer isolated from system,  
reference TM 55-1905-223-10.

#### Materials/Parts

2-1/2-inch sediment strainer  
P/N AN-2.5-125F-B-C  
Sediment strainer element  
P/N BK-2.5-125F-01-4A  
Cover gasket P/N TG-2.5-125F-01-BA  
Basket gasket P/N BG-2.5-125F-01-BA

---

### REMOVAL

- a. Place a drip pan under 2-1/2 inch sediment strainer (3, FIGURE 2-246).
- b. Remove flange nuts (2) and bolts (1).
- c. Remove sediment strainer (3).

### DISASSEMBLY

- a. Turn knob (1, FIGURE 2-247) and remove cover (2).
- b. Remove cover gasket (3).
- c. Remove sediment strainer element (4).
- d. Remove basket gasket (5).

### REPAIR

Repair at this level of maintenance is by replacement of cover gasket (3), basket gasket (5), sediment strainer element (4), or entire assembly.

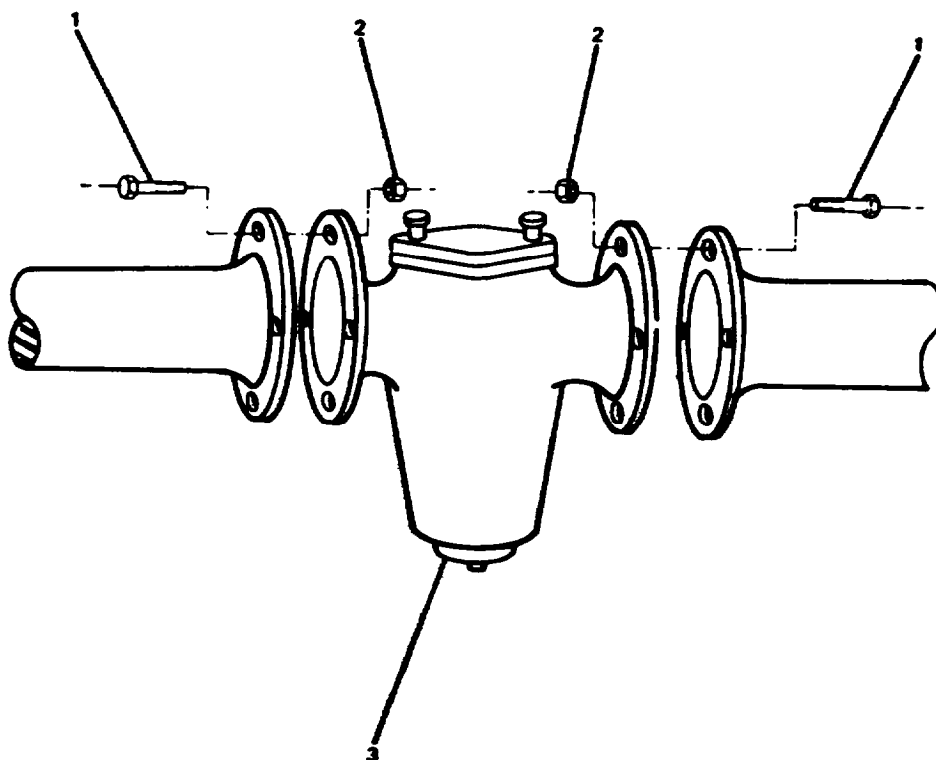


FIGURE 2-246. 2-1/2 Inch Sediment Strainer Basket, Removal.

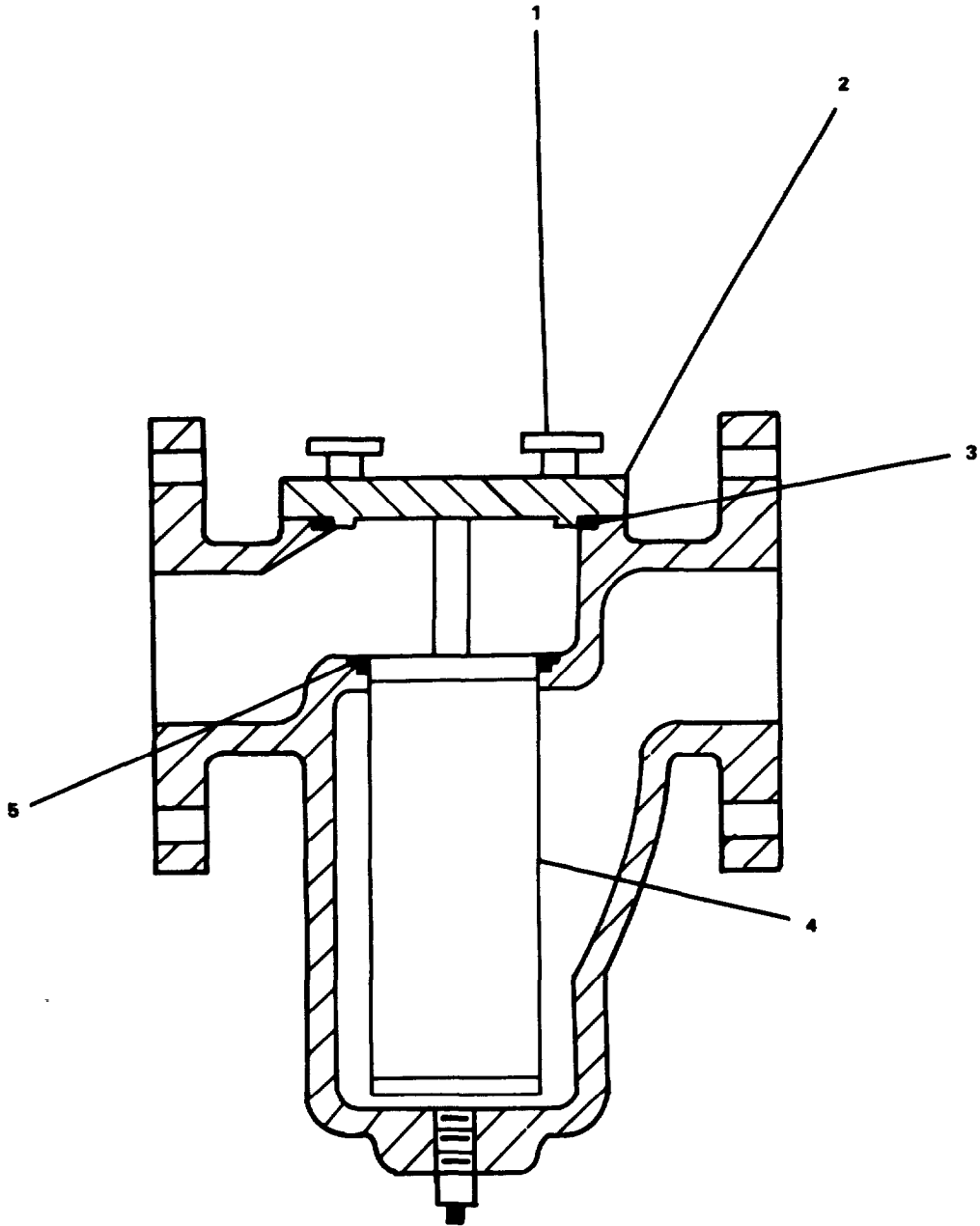


FIGURE 2-247. 2-1/2 Inch Sediment Strainer Basket, Repair.

**ASSEMBLY**

- a. Install basket gasket (5, FIGURE 2-247) and basket (4) in sediment strainer.
- b. Install cover gasket (3) and cover (2).
- c. Tighten knob (1).

**REPLACEMENT**

- a. Install 2-1/2 inch sediment strainer (3, FIGURE 2-246) and attach with bolts (1).
- b. Install nut (2) and torque to 50 ft-lb (68 N•m).
- c. Charge pipeline and check for leaks.
- d. Remove drip pan.

**2-317.1. Strainer, 1/2 Inch Wye. (FIGURE 2-247A)**

This task covers:      a. Inspect,      b. Service,      c. Removal,      d. Repair,      e. Replacement.

**INITIAL SETUP****Tools**

Tool Kit, General Mechanic's,  
5180-00-699-5273

**Materials/Parts**

Strainer, 1/2 Inch Wye, P/N 3500189-002  
Strainer Element P/N 3500192-002  
Strainer Gasket P/N 3500192-008  
Warning Tags, Item 1, Appendix C  
Utility Pail, Item 13, Appendix C

**Equipment Condition**

TM 55-1905-223-10, Marine Sanitation Device and  
Auxiliary Seawater Pump Secured, Locked Out  
and Tagged (FM 55-502).

**General Safety Instructions****WARNING**

**Ensure system is turned OFF and tagged to  
prevent operation during maintenance.  
Generated pressure could cause injury.**

**Use extreme care when breaking system  
connections. Escaping pressure and or  
fluids could cause injury.**

**Clean up spills immediately. Spills create an  
unsafe working area.**

**INSPECTION**

Inspection of the wye strainer is accomplished through Preventive Maintenance Checks and Services (PMCS), Table 2-1.

**SERVICE**

Service consists of cleaning the element (3) and gasket (2) with clean water and inspecting for damage, tears or holes in the mesh. Replace as necessary.

**REMOVAL**

- a. Isolate the Wye strainer (1) from piping system.
  - (1) Trace inlet and outlet piping to nearest pipe union.
  - (2) Continue tracing to nearest manually operated valves.
  - (3) Close the inlet and outlet manually operated valves.

**WARNING**

**Clean up spills immediately. Spills create an unsafe working area.**

- b. Remove strainer element from strainer.
  - (1) Position pail to catch spillage.
  - (2) Turn element (3) in a counter clockwise direction, remove from strainer.

- (3) Remove gasket (2) from element.
- (4) At this point service and repair procedures may be accomplished, for strainer removal continue to step c.

**WARNING**

**Clean up spills immediately. Spills create an unsafe working area.**

- c. Remove strainer from piping.
  - (1) Position pail to catch spillage.
  - (2) Separate inlet and outlet piping by disconnecting the pipe unions.
  - (3) Remove wye strainer with piping attached.
- d. Remove piping from wye strainer.
  - (1) Hold wye strainer stationary and turn piping in a counter clockwise direction to remove.
  - (2) Remove piping from the wye strainer.

**REPAIR**

Repair of the Wye strainer is by replacement of the gasket (2) and strainer element (3).

**REPLACEMENT**

- a. Replace piping on the wye strainer.
  - (1) Hold wye strainer stationary and turn piping in a clockwise direction to replace.
- b. Replace wye strainer with piping attached.
  - (1) Connect inlet and outlet piping by reconnecting the pipe unions.
- c. Replace strainer element in strainer.
  - (1) Replace gasket (2) onto element (3).
  - (2) Install element in strainer by turning in a clockwise direction.
- d. Operational check.
  - (1) Remove warning tags.
  - (2) Operate system; refer to TM 55-1905-223-10.
  - (3) Open shutoff valves.
  - (4) Check for leaks in system and retighten connections as necessary.

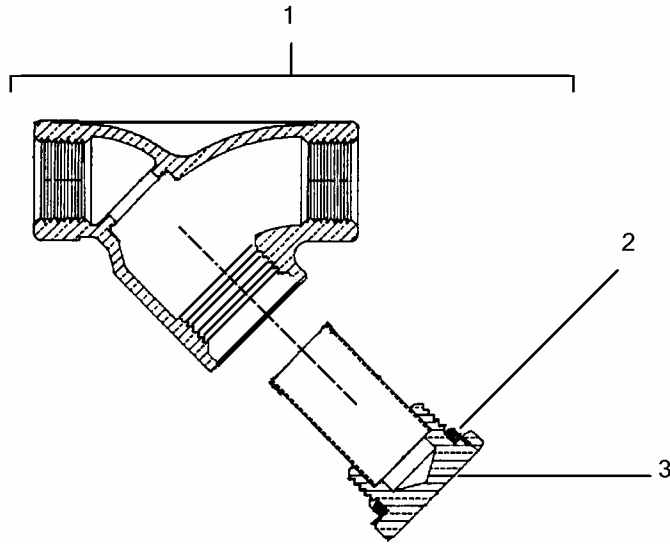


Figure 2-247A. Strainer, 1/2 Inch Wye (Typical).





---

2-318. Replace/Repair 3-Inch Duplex Sediment Strainer.

---

This task covers: a. Removal, b. Disassembly, c. Repair, d. Assembly,  
e. Replacement.

---

### INITIAL SETUP

#### Tools

Tool kit, general mechanic's  
5180-00-699-5273  
Torque wrench (30-300 ft-lb),  
5120-01-125-5190  
Lifting sling P/N 3375958

#### Equipment Condition

Piping system shut down.  
Strainer isolated from system,  
reference TM 55-1905-223-10.

#### Materials/Parts

Preformed packing P/N ST266Z5B (2)  
Strainer sediment element (2)  
P/N ST051030M060 SB

---

### REMOVAL

- a. Place a drip pan under duplex sediment strainer (1, FIGURE 2-248) and remove pipe plugs (2).
- b. Replace pipe plug after draining strainer.
- c. Remove nuts (4) and bolts (3).
- d. Remove mounting bolts (5).

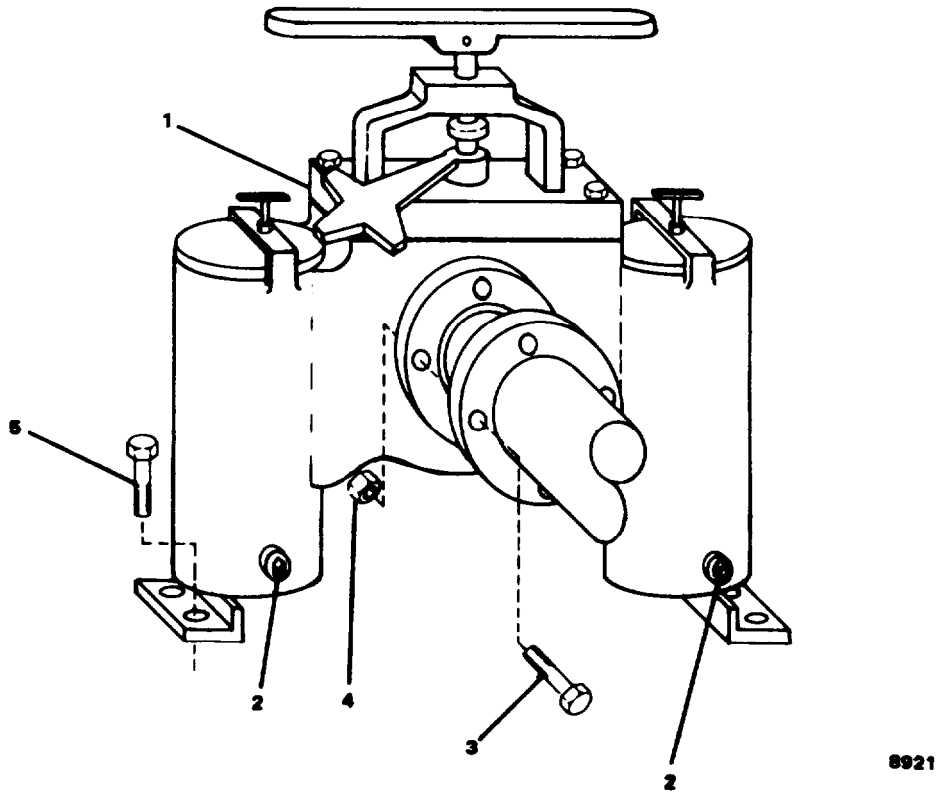
#### NOTE

The duplex sediment strainer is heavy and will require two soldiers or a chain hoist to remove.

- e. Remove duplex sediment strainer.

### DISASSEMBLY

- a. Remove headless straight pin (2, FIGURE 2-249) and lifting handle (1).
- b. Loosen T-bolt assembly (3, 10).



8921

FIGURE 2-248. Replace/Repair 3-Inch Duplex Sediment Strainer.

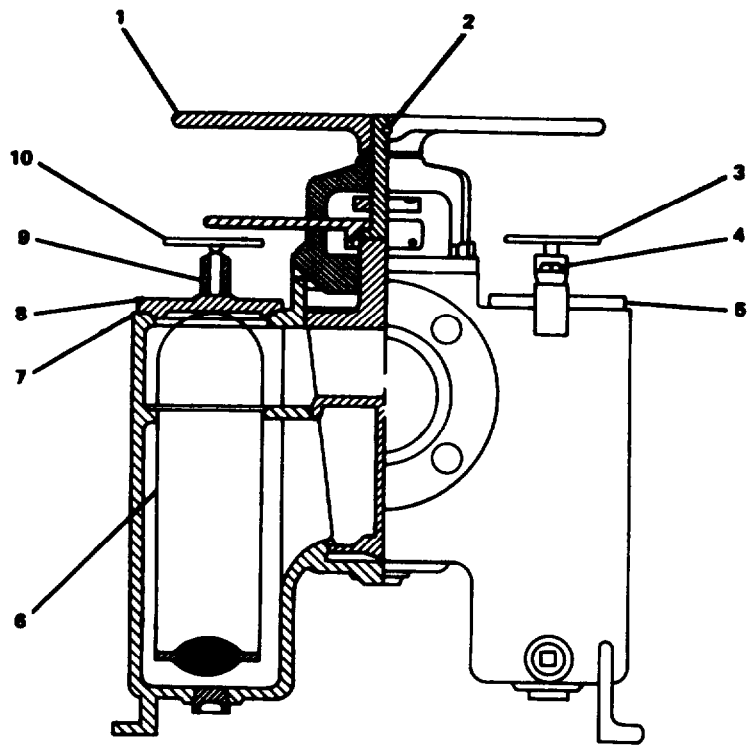


FIGURE 2-249. Replace/Repair 3-Inch Duplex Sediment Strainer.

- c. Rotate basket well yoke (4, 9) to clear basket well cover (5, 8).
- d. Remove cover and preformed packing (7).
- e. Remove sediment strainer element (6).

### **REPAIR**

Repair at this level of maintenance is by replacement of preformed packings (7), sediment strainer element (6).

### **ASSEMBLY**

- a. Install sediment strainer element (6, FIGURE 2-249).
- b. Install preformed packings (7) and covers (5, 8).
- c. Rotate basket well yoke (4, 9) over covers.
- d. Tighten T-bolt assemble (3, 10).
- e. Install lifting handle (1) and headless straight pin (2).

### **REPLACEMENT**

#### **NOTE**

The duplex sediment strainer is heavy and will require two soldiers or a chain hoist to replace.

- a. Install duplex sediment strainer (1, FIGURE 2-248).
- b. Install mounting bolts (5) and torque to 75 ft-lb (102 N•m).
- c. Install bolts (3), nut (4) and torque to 75 ft-lb (102 N•m).
- d. Charge piping system and check for leaks.
- e. Remove drip pan.

MAINTENANCE OF PIPING SYSTEM, POTABLE WATER

---

2-319. Repair Threaded Valves. (FIGURE 2-250)

---

This task covers: Repair.

---

INITIAL SETUP

Tools

Tool kit, general mechanic's,  
5180-00-699-5273

Materials/Parts

Piping system, potable water  
P/N 8532028, refer to  
TN 55-1905-223-241  
Anti-seize compound, Item 15,  
Appendix C  
Warning tags, Item 1, Appendix C  
Utility pail, Item 13, Appendix C

Equipment Condition

At Auxiliary Machinery Motor Control Center press No. 1 fresh water maker pump STOP pushbutton and set P205-4 circuit breaker to the OFF position. Press No. 2 fresh water maker pump STOP pushbutton and set P205-5 circuit breaker to the OFF position. Tag switches "Out of Service - Do Not Operate."

---

REMOVAL

WARNING

Use extreme care when disconnecting.  
Escaping system pressure or fluid could  
cause injury.

**NOTE**

All threaded type valves are replaced in the same manner.

- a. Isolate valve (7) from piping system.
  - (1) Trace inlet piping (2) to nearest pipe union (3).
  - (2) Close shutoff valve (1).

- (3) Trace outlet piping (12) to nearest pipe union (9).
  - (4) Continue tracing to nearest manually operated shutoff valve (13).
  - (5) Close shutoff valve (13).
- b. Remove valve (7) from piping system.

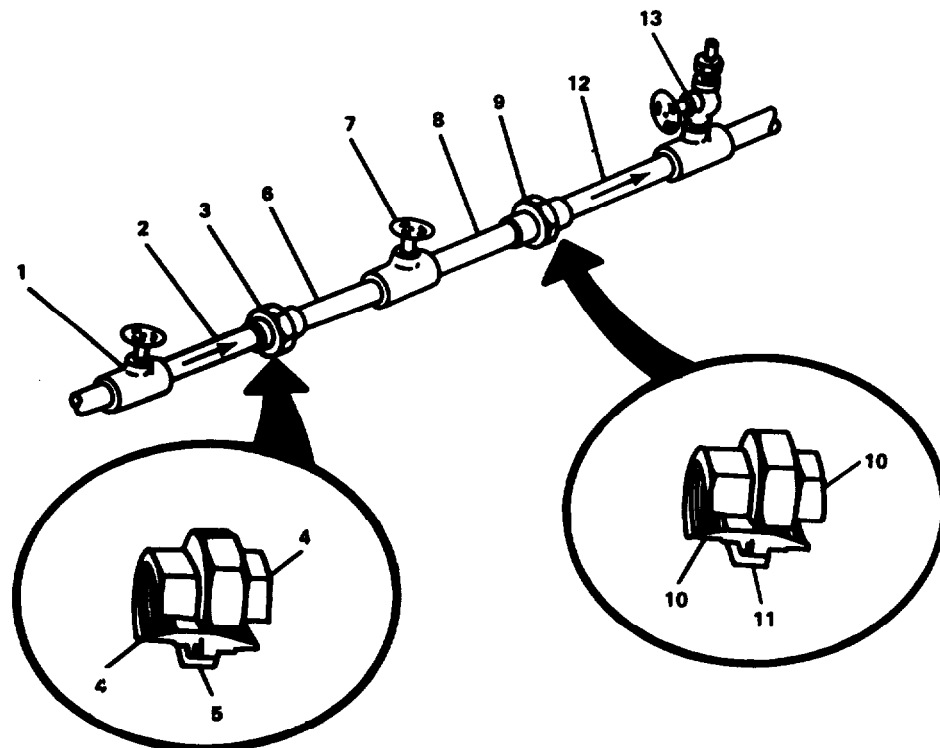
**WARNING**

**Clean up spills immediately. Spills create an unsafe working area.**

- (1) Position pail to catch spillage.
- (2) Separate inlet piping (2) and outlet piping (12) by holding tail piece (4, 10) of each union (3, 9) and turning collar (5, 10) counterclockwise.
- (3) Remove valve (7) with piping (6, 8) attached.

**NOTE**

Threaded gate valve shown, typical breakdown for all threaded type valves.



**NOTE: THREADED GATE VALVE SHOWN, TYPICAL BREAKDOWN FOR ALL THREADED TYPE VALVES.**

FIGURE 2-250. Repair of Threaded Valves (Typical).

- c. Remove piping from valve (7).
  - (1) Hold valve (7) stationary and turn attached piping (6, 8) counterclockwise to remove.
  - (2) Remove piping (6, 8) from valve (7).

### **REPAIR**

Repair at this level of maintenance is by replacement of the threaded valves in the potable water piping system.

### **REPLACEMENT**

#### **CAUTION**

To prevent damaging system make sure check valves are installed so that the disc will open with the direction of flow.

#### **NOTE**

Coat threads of all piping and fittings with anti-seize compound.

- a. Install piping in valve (7).
  - (1) Hold valve (7) stationary and thread piping (6, 8) into each port of valve in a clockwise direction until tight.
- b. Install valve (7) in piping system.
  - (1) Position valve (7) with attached piping (6, 8) into piping system.
  - (2) Adjust piping as needed to align tail piece (4, 10) of each union (3, 9) with collar (5, 10).
  - (3) Connect inlet piping (2) and outlet piping (12) by holding tail piece (4, 10) of each union (3, 9) stationary and threading collar (5, 10) in a clockwise direction until tight.
- c. Operational check.
  - (1) Remove warning tags.
  - (2) Operate system; refer to TM 55-1905-223-10.
  - (3) Open shutoff valves (1) and (13).
  - (4) Check for leaks in system and retighten connections as necessary.

---

**2-320. Repair Threaded Fittings. (FIGURE 2-251)**

---

This task covers: a. Removal, b. Repair, c. Replacement.

---

**INITIAL SETUP****Tools**

Tool kit, general mechanic's,  
5180-00-699-5273

**Materials/Parts**

Piping system, potable water  
P/N 8532028, refer to  
TM 55-1905-223-24P  
Anti-seize compound, Item 15,  
Appendix C  
Warning tags, Item 1, Appendix C  
Utility pail, Item 15, Appendix C

**Equipment Condition**

At Auxiliary Machinery Motor Control Center press No. 1 fresh water maker pump STOP pushbutton and set P205-4 circuit breaker to the OFF position. Press No. 2 fresh water maker pump STOP pushbutton and set P205-5 circuit breaker to the OFF position. Tag switches "Out of Service - Do Not Operate."

---

**REMOVAL****WARNING**

**Use extreme care when disconnecting. Escaping system pressure or fluid could cause injury.**

**NOTE**

All threaded type fittings are replaced in the same manner.

- a. Isolate fitting from piping system.
  - (1) Trace inlet pipings (3) to nearest pipe coupling (2).
  - (2) Continue tracing to nearest manually operated shutoff valve (1).
  - (3) Close shutoff valve (1).
  - (4) Trace outlet piping (5) to nearest pipe union (6).

(5) Continue tracing to nearest manually operated shutoff valve (9).

(6) Close shutoff valve (9).

b. Remove fitting from piping.

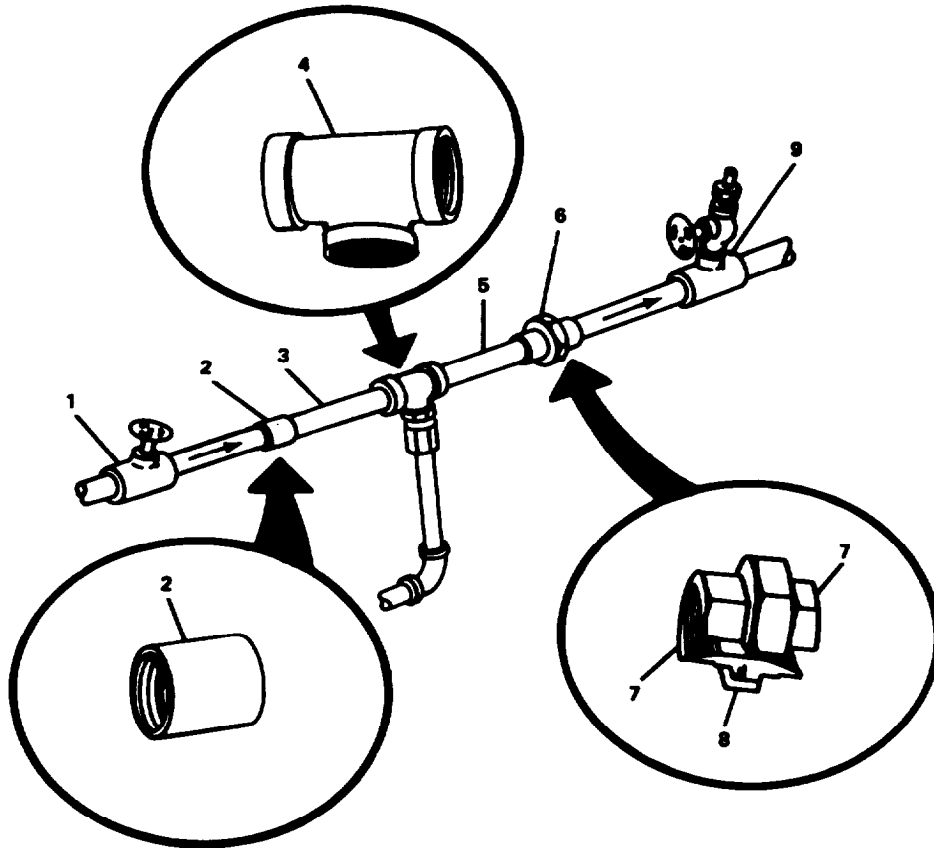


FIGURE 2-251. Repair Threaded Fittings (Typical).

**WARNING**

**Clean up spills immediately. Spills create an unsafe working area.**

- (1) Position pail to catch spillage.
- (2) Separate outlet piping (5) by holding tail piece (7) of union (6) and turning collar (8) counterclockwise.
- (3) Disconnect union (6) from pipe (5).
- (4) Remove outlet piping (5) from tee (4).
- (5) Remove tee (4) from inlet piping (3).
- (6) Remove coupling (2) from inlet piping (3).



**REPAIR**

Repair at this level of maintenance is by replacement of the threaded fittings in the potable water piping system.

**REPLACEMENT****NOTE**

Coat threads of all fittings with anti-seize compound.

- a. Install fittings in piping.
  - (1) Install coupling (2) on inlet piping (3).
  - (2) Connect union (6) to tee (4).
  - (3) Install tee (4) on inlet piping (3).
  - (4) Install outlet piping (5) on tee (4).
  - (5) Connect outlet piping (5) at union (6) by holding tail piece (7) of union (6) and turning collar (8) clockwise.
- b. Operational check.
  - (1) Remove warning tags.
  - (2) Open shutoff valves (1) and (9).
  - (3) Operate system; refer to TM 55-1905-223-10.
  - (4) Check for leaks in system and retighten connections as necessary.

2-321. Repair Differential Pressure Gauge. (FIGURE 2-252)

---

This task covers: a. Removal, b. Repair, c. Replacement.

---

INITIAL SETUP

Tools

Tool kit, general mechanic's,  
5180-00-699-5273

Materials/Parts

Pressure gauge P/N 33-1745-1075  
Teflon tape, Item 5, Appendix C  
Warning tags, Item 1, Appendix C

Equipment Condition

At Auxiliary machinery Motor Control Center press No. 1 fresh water maker pump STOP pushbutton and set P205-4 circuit breaker to the OFF position. Press No. 2 fresh water maker pump STOP pushbutton and set P205-5 circuit breaker to the OFF position. Tag switches "Out of Service - Do Not Operate."

---

REMOVAL

- a. Close fresh water pump suction and discharge valves.
- b. Disconnect tubing (3) from tee (4).
- c. Remove tee (4) from reducer (5).
- d. Remove reducer (5) from pressure gauge (1).
- e. Remove capscrews (2) from pressure gauge (1).
- f. Remove pressure gauge (1) from bulkhead.

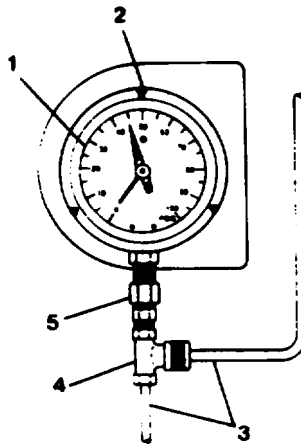


FIGURE 2-252. Repair Differential Pressure Gauge.

**REPAIR**

Repair at this level of maintenance is by replacement of pressure gauge (1).

**REPLACEMENT**

- a. Replace pressure gauge (1).
  - (1) Place pressure gauge (1) in position and secure using capscrews (2).
  - (2) Apply teflon tape to fitting on pressure gauge (1).
  - (3) Install reducer (5) on pressure gauge (1).
  - (4) Install tee (4) on reducer (5).
  - (5) Connect tubing (3) to tee (4).
- b. Operational check.
  - (1) Remove warning tags.
  - (2) Open fresh water pump suction and discharge valves.
  - (3) Operate system; refer to TM 55-1905-223-10.
  - (4) Check for leaks in system; retighten connections as necessary.
  - (5) Check pressure gauge for proper operation.

2-322. Repair Pressure Switch. (FIGURE 2-253)

---

This task covers: a. Removal, b. Repair, c. Replacement.

---

INITIAL SETUP

Tools

Tool kit, general mechanic's,  
5180-00-699-5273

Materials/Parts

Pressure switch P/N 57-7341-0000  
Pressure switch P/N 57-7341-0001  
Teflon tape, Item 5, Appendix C  
Warning tags, Item 1, Appendix C

Equipment Condition

At Auxiliary Machinery Motor Control Center press No. 1 fresh water maker pump STOP pushbutton and set P205-4 circuit breaker to the OFF position. Press No. 2 fresh water maker pump STOP pushbutton and set P205-5 circuit breaker to the OFF position. Tag switches "Out of Service - Do Not Operate."

---

REMOVAL

- a. Close fresh water pump suction and discharge valves.
- b. Disconnect electrical connector (1) from pressure switch (2).
- c. Disconnect tubing (5) from bottom of pressure switch (2).
- d. Remove fitting (4) from bottom of pressure switch (2).
- e. Remove nuts (3) from pressure switch (2).
- f. Remove pressure switch (2) from bulkhead.

REPAIR

Repair at this level of maintenance is by replacement of pressure switches (2).

REPLACEMENT

- a. Install pressure switch (2).
  - (1) Place pressure switch (2) on bulkhead and secure with nuts (3).
  - (2) Apply teflon tape to fitting (4).

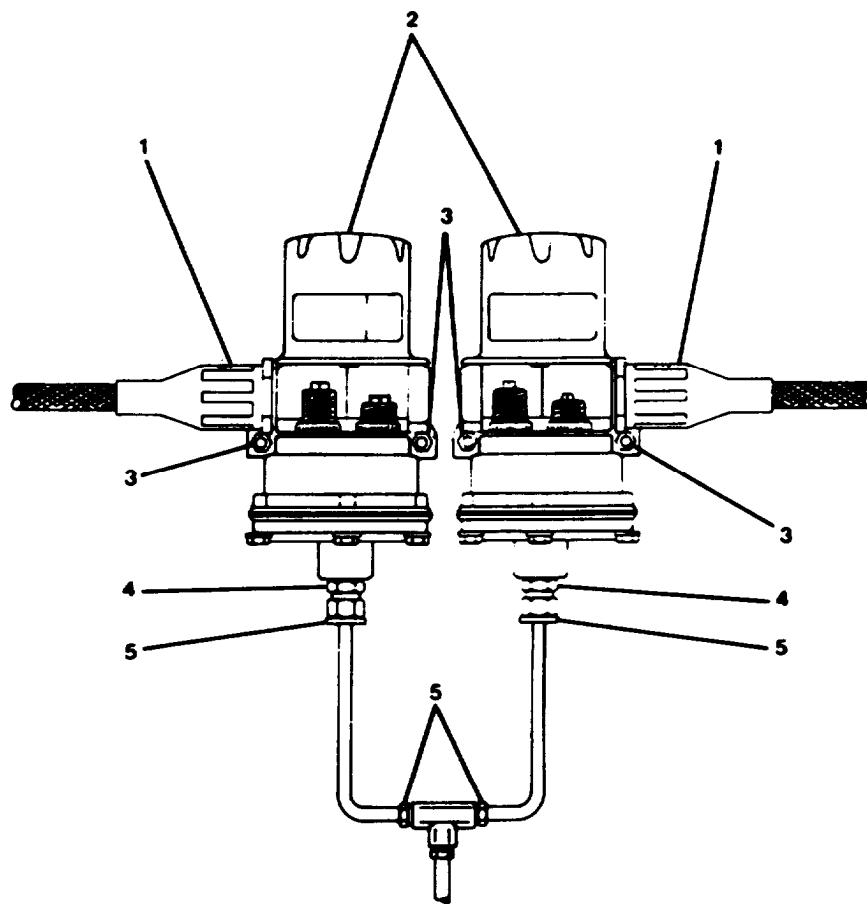


FIGURE 2-253. Repair Pressure Switch.

**TM 55-1905-223-24-18-1**

- (3) Install fitting (4) in bottom of pressure switch (2).
- (4) Connect tubing (5) to bottom of pressure switch (2).
- (5) Connect electrical connector (1) to pressure switch (2).

b. Operational check.

- (1) Remove warning tags.
- (2) Open fresh water pump suction and discharge valves.
- (3) Operate system; refer to TM 55-1905-223-10.
- (4) Check for leaks in system; retighten connections as necessary.
- (5) Check pressure switch for proper operation.

2-323. Repair Lavatory Faucet. (FIGURE 2-254)

This task covers: a. Removal, b. Repair, c. Replacement.

**INITIAL SETUP**

**Tools**

Tool kit, general mechanic's,  
5180-00-699-5273

**Materials/Parts**

Piping system, potable water  
P/N 8532028, refer to  
TM 55-1905-223-24P  
Teflon tape, Item 5, Appendix C

**Equipment Condition**

At Auxiliary Machinery Motor Control Center press No. 1 fresh water maker pump STOP pushbutton and set P205-4 circuit breaker to the OFF position. Press No. 2 fresh water maker pump STOP pushbutton and set P205-5 circuit breaker to the OFF position. Tag switches "Out of Service - Do Not Operate."

**REMOVAL**

- a. Close hot water supply valve (2).
- b. Close cold water supply valve (1).

**NOTE**

Open faucets to relieve water pressure before removing faucet.

- c. Remove screws (4) from top of lavatory faucet (3).
- d. Remove handles (5) from faucet (3).
- e. Remove covers (6) from top of lavatory faucet (3).
- f. Remove nuts (7) from top of lavatory faucet (3).
- g. Remove rubber washers (8) from top of lavatory faucet (3).
- h. Disconnect joint adapters (12) from manifold (11).
- i. Remove faucet (16) from top of lavatory.
- j. Disconnect flared coupling (13) from faucet (16).
- k. Remove manifold (11) with nuts (10) and washers (9) attached from bottom of lavatory.

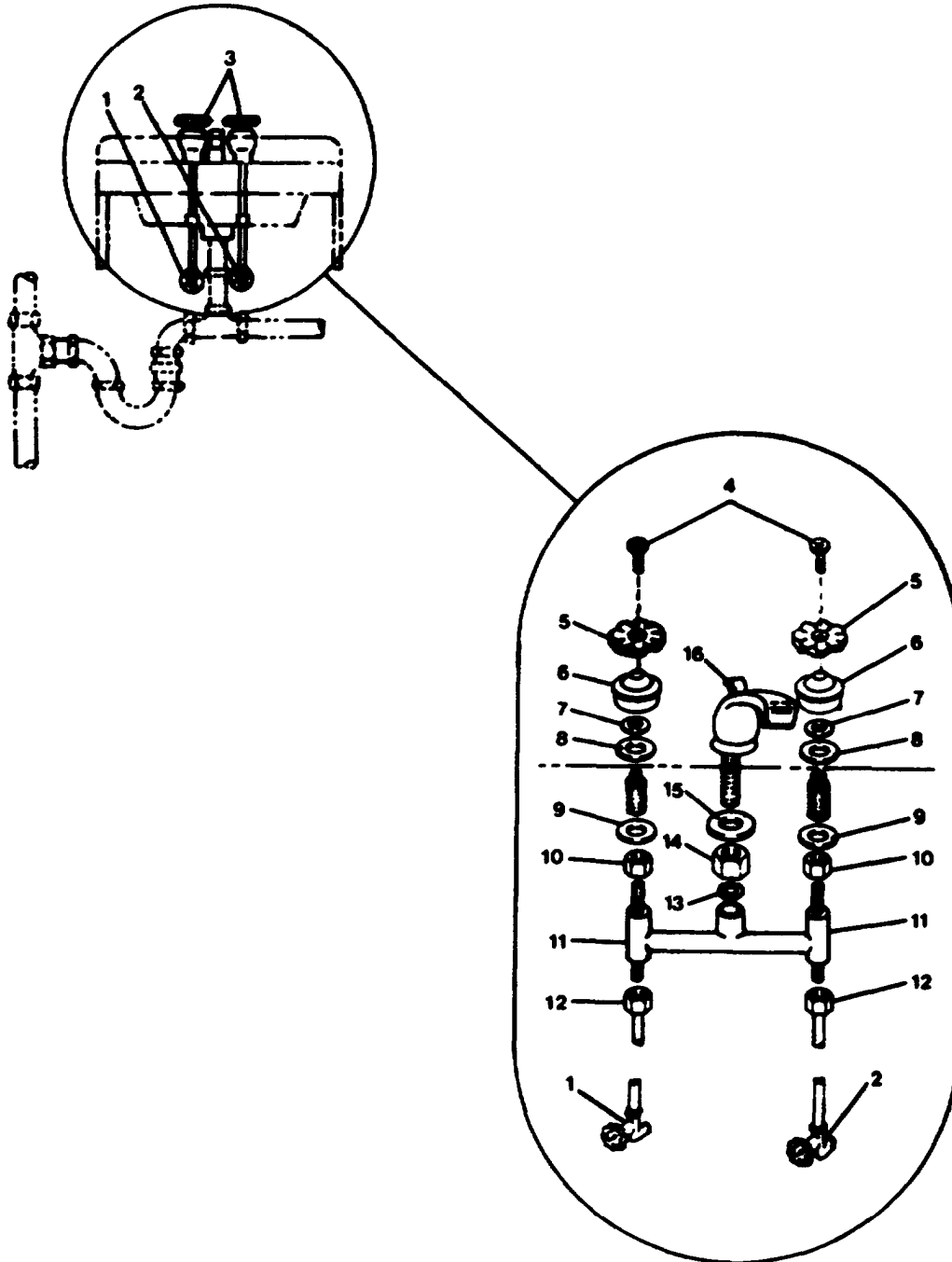


FIGURE 2-254. Repair Lavatory Faucet.



- I. Remove jam nut (14) and washer (15) from faucet (16).

### **REPAIR**

Repair at this level of maintenance is by replacement of the lavatory faucet (3).

### **REPLACEMENT**

#### NOTE

Apply teflon tape to all threaded connections prior to assembly.

- a. Connect flared coupling (13) to faucet (16).

#### NOTE

Do not tighten until all nuts and fittings are installed.

- b. Install jam nut (14) and washer (15) on faucet (16).
- c. Position faucet (16) in top of lavatory.
- d. Position manifold (11) with nuts (10) and washers (9) attached in bottom of lavatory.
- e. Connect joint adapters (12) to manifold (11).
- f. Install rubber washers (8) on top of lavatory faucet (3).
- g. Install nuts (7) on top of faucet (3).
- h. Tighten all nuts and fittings.
- i. Install covers (6) on top of lavatory faucet (3).
- j. Install handles (5) on faucet (3).
- k. Install screws (4) and tighten.
- l. Open cold water supply valve (1) and hot water supply valve (2).
- m. Check faucet fittings for leaks and retighten as necessary.

2-324. Repair Galley Faucet. (FIGURE 2-255)

---

This task covers: a. Removal, b. Repair, c. Replacement.

---

**INITIAL SETUP**

**Tools**

Tool kit, general mechanic's,  
5180-00-699-5273

**Materials/Parts**

Piping system, potable water  
P/N 8532028, refer to  
TM 55-1905-223-24P  
Teflon tape, Item 5, Appendix C

**Equipment Condition**

At Auxiliary Machinery Motor Control Center press No. 1 fresh water maker pump STOP pushbutton and set P205-4 circuit breaker to the OFF position. Press No. 2 fresh water maker pump STOP pushbutton and set P205-5 circuit breaker to the OFF position. Tag switches "Out of Service - Do Not Operate."

---

**REMOVAL**

- a. Close cold water supply valve (3).
- b. Close hot water supply valve (4).

NOTE

Open faucets to relieve water pressure before removing faucet.

- c. Disconnect flared coupling (2) from bottom of faucet (1) and flared coupling (5) from bottom of faucet (1).
- d. Remove jam nuts (7) and washers (6) from faucet (1).
- e. Remove faucet (1) from galley sink.

**REPAIR**

Repair at this level of maintenance is by replacement of galley faucet (1).

**REPLACEMENT**

NOTE

Apply teflon tape to all threaded connections prior to assembly.

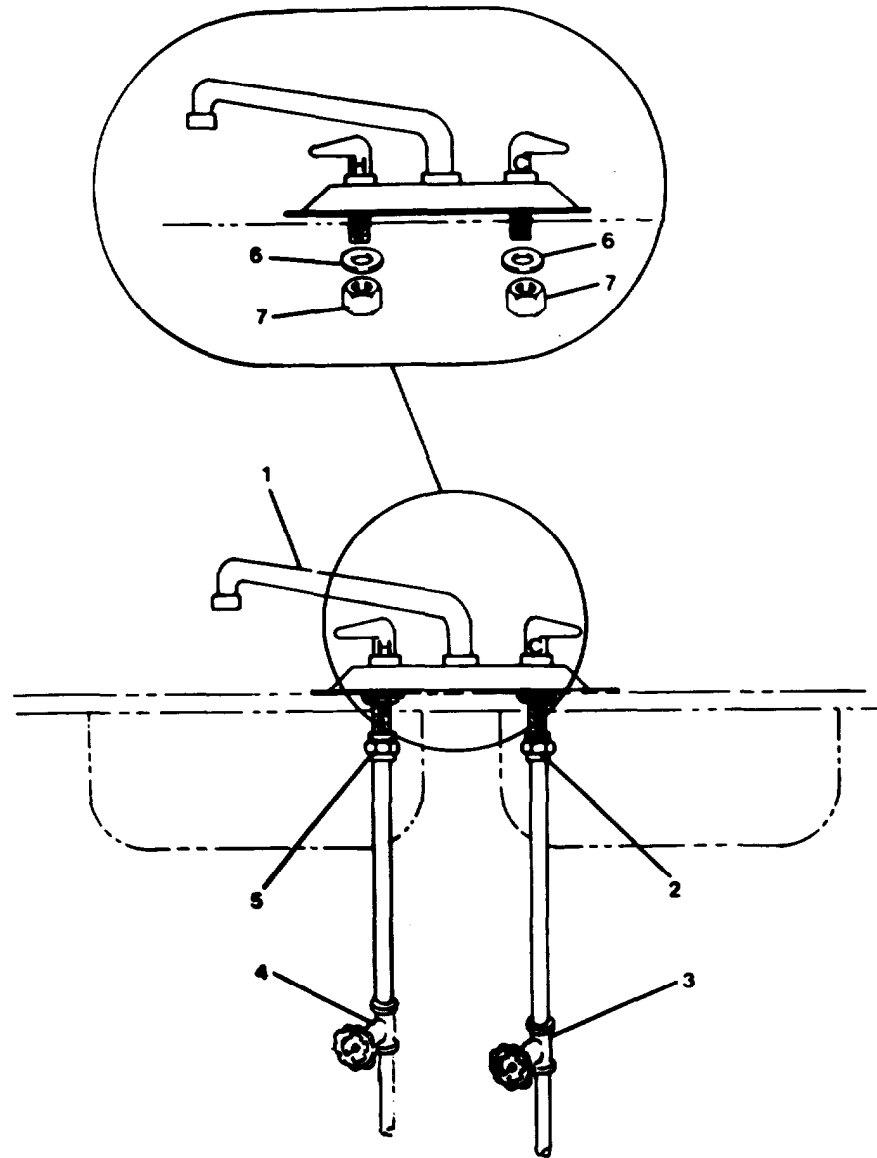


FIGURE 2-255. Repair Galley Faucet.

- a. Position faucet (1) in galley sink.
- b. Install washers (6) and jam nuts (7) on bottom of faucet (1) and tighten.
- c. Connect flared coupling (2) to bottom of faucet (1).
- d. Connect flared coupling (5) to bottom of faucet (1).
- e. Tighten couplings (2, 5).
- f. Open hot water supply valve (4) and cold water supply valve (3).
- g. Check faucet connections for leaks and retighten as necessary.

---

 2-325. Repair Laundry Tub Faucet. (FIGURE 2-256)
 

---

This task covers: a. Removal, b. Repair, c. Replacement.

---

**INITIAL SETUP**
**Tools**

Tool kit, general mechanic's,  
5180-00-699-5273

**Materials/Parts**

Piping system, potable water  
P/N 8532028, refer to  
TM 55-1905-223-24P  
Teflon tape, Item 5, Appendix C

**Equipment Condition**

At Auxiliary Machinery Motor Control Center press No. 1 fresh water maker pump STOP pushbutton and set P205-4 circuit breaker to the OFF position. Press No. 2 fresh water maker pump STOP pushbutton and set P205-5 circuit breaker to the OFF position. Tag switches "Out of Service - Do Not Operate."

---

**REMOVAL**

- a. Close hot water supply valve (1).
- b. Close cold water supply valve (2).

## NOTE

Open faucets to relieve water pressure before removing faucet.

- c. Disconnect flared coupling (4) from hot water connection on back of faucet (3).
- d. Disconnect flared coupling (5) from cold water connection on back of faucet (3).
- e. Remove jam nuts (6) and washers (7) from back of faucet (3).
- f. Remove faucet (3) from laundry sink.

**REPAIR**

Repair at this level of maintenance is by replacement of laundry tub faucet (3).

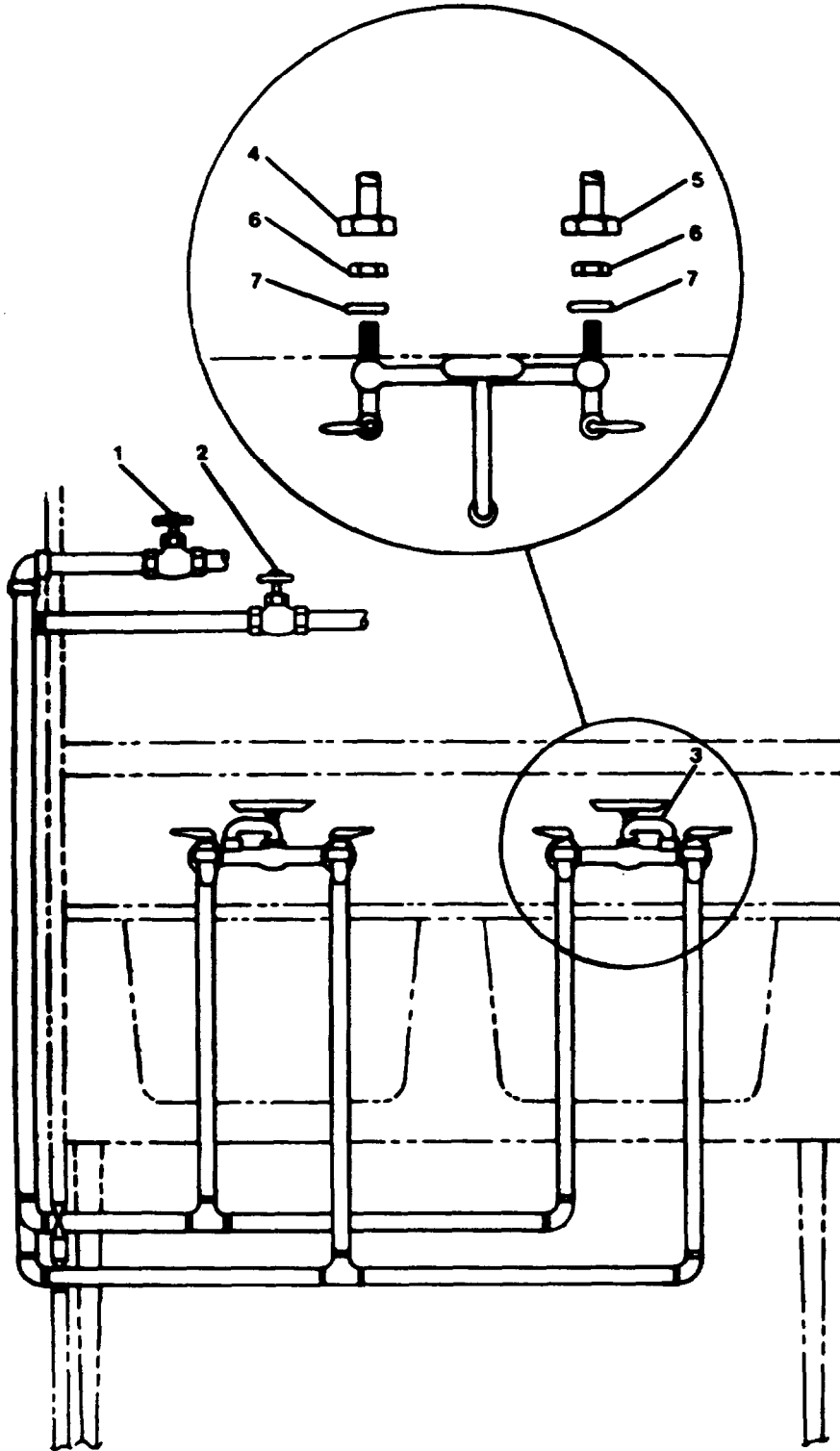


FIGURE 2-256. Repair Laundry Tub Faucet.

**REPLACEMENT**

## NOTE

Apply teflon tape to all connections prior to assembly.

- a. Position faucet (3) in laundry sink.
- b. Install washers (7) and jam nuts (6) on back of faucet (3).
- c. Tighten jam nuts (6).
- d. Connect flared coupling (5) to cold water connection on back of faucet (3).
- e. Connect flared coupling (4) to hot water connection on back of faucet (1).
- f. Tighten both coupling.
- g. Open cold water supply valve (2).
- h. Open hot water supply valve (1).
- i. Check faucet connections for leaks and retighten as necessary.

---

2-326. Repair Shower Safety Unit. (FIGURE 2-257)

---

This task covers: a. Removal, b. Repair, c. Replacement.

---

**INITIAL SETUP**

**Tools**

Tool kit, general mechanic's,  
5180-00-699-5273

**Materials/Parts**

Piping system, potable water  
P/N 8532028, refer to  
TM 55-1905-223-24P  
Teflon tape, Item 5, Appendix C

**Equipment Condition**

At Auxiliary Machinery Motor Control Center press No. 1 fresh water maker pump STOP pushbutton and set P205-4 circuit breaker to the OFF position, Press No. 2 fresh water maker pump STOP pushbutton and set P205-5 circuit breaker to the OFF position, Tag switches "Out of Service - Do Not Operate."

---

**REMOVAL**

- a. Close hot water supply valve (1).
- b. Close cold water supply valve (2).

**NOTE**

Open faucets to relieve water pressure before removing faucet.

- c. Disconnect flared couplings (3).
- d. Remove shower unit (4) from shower stall.

**REPAIR**

Repair at this level of maintenance is by replacement of shower unit (4).

**REPLACEMENT**

**NOTE**

Apply teflon tape to all threaded connections prior to assembly.

- a. Position shower unit (4) in shower stall.
- b. Connect flared coupling (3) and tighten.



- c. Open hot water supply valve (1) and cold water supply valve (2).
- d. Check shower unit connections for leaks and retighten as necessary.

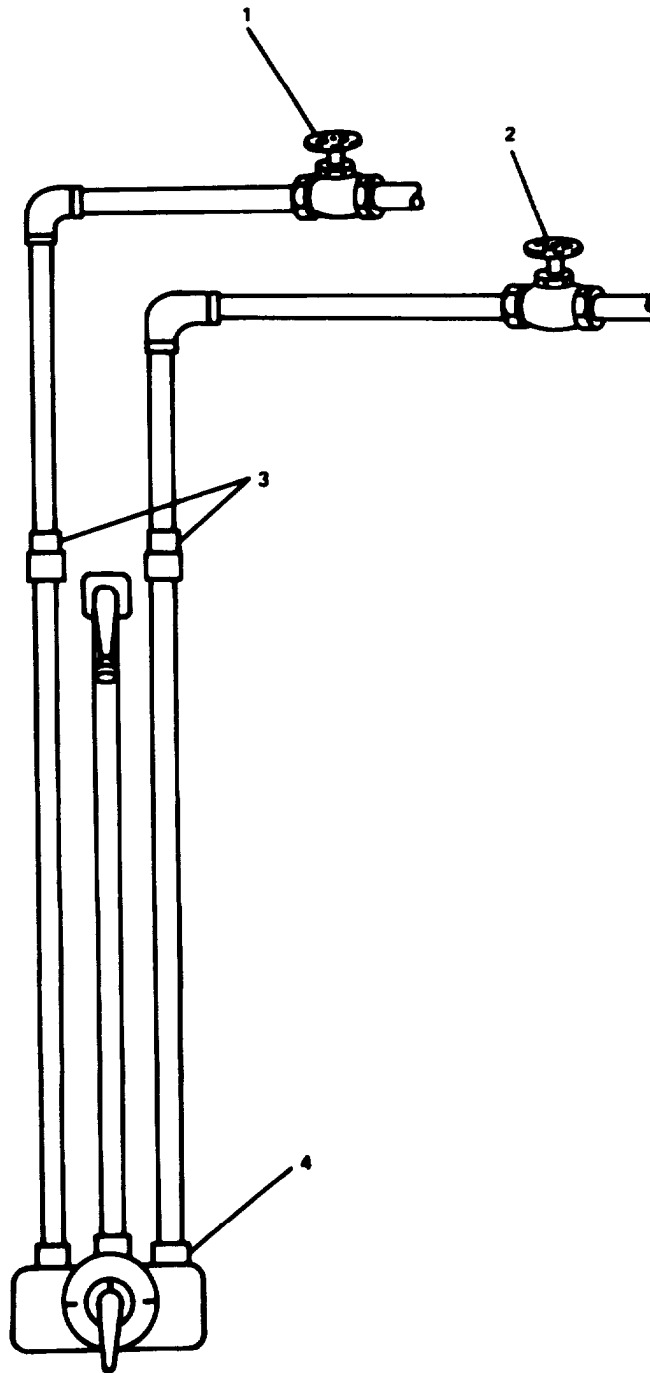


FIGURE 2-257. Repair Shower Safety Unit.

2-327. Repair Flush Valves. (FIGURE 2-258)

---

This task covers: a. Removal, b. Repair, c. Replacement.

---

**INITIAL SETUP**

**Tools**

Tool kit, general mechanic's,  
5180-00-699-5273

**Materials/Parts**

Piping system, potable water  
P/N 8532028, refer to  
TM 55-1905-223-24P  
Teflon tape, Item 5, Appendix C

**Equipment Condition**

At Auxiliary Machinery Motor Control Center press No. 1 fresh water maker pump STOP pushbutton and set P205-4 circuit breaker to the OFF position. Press No. 2 fresh water maker pump STOP pushbutton and set P205-5 circuit breaker to the OFF position. Tag switches "Out of Service - Do Not Operate."

---

**REMOVAL**

NOTE

Urinal and water closet flush valves are replaced in the same manner.

- a. Close fresh water supply valve (1).

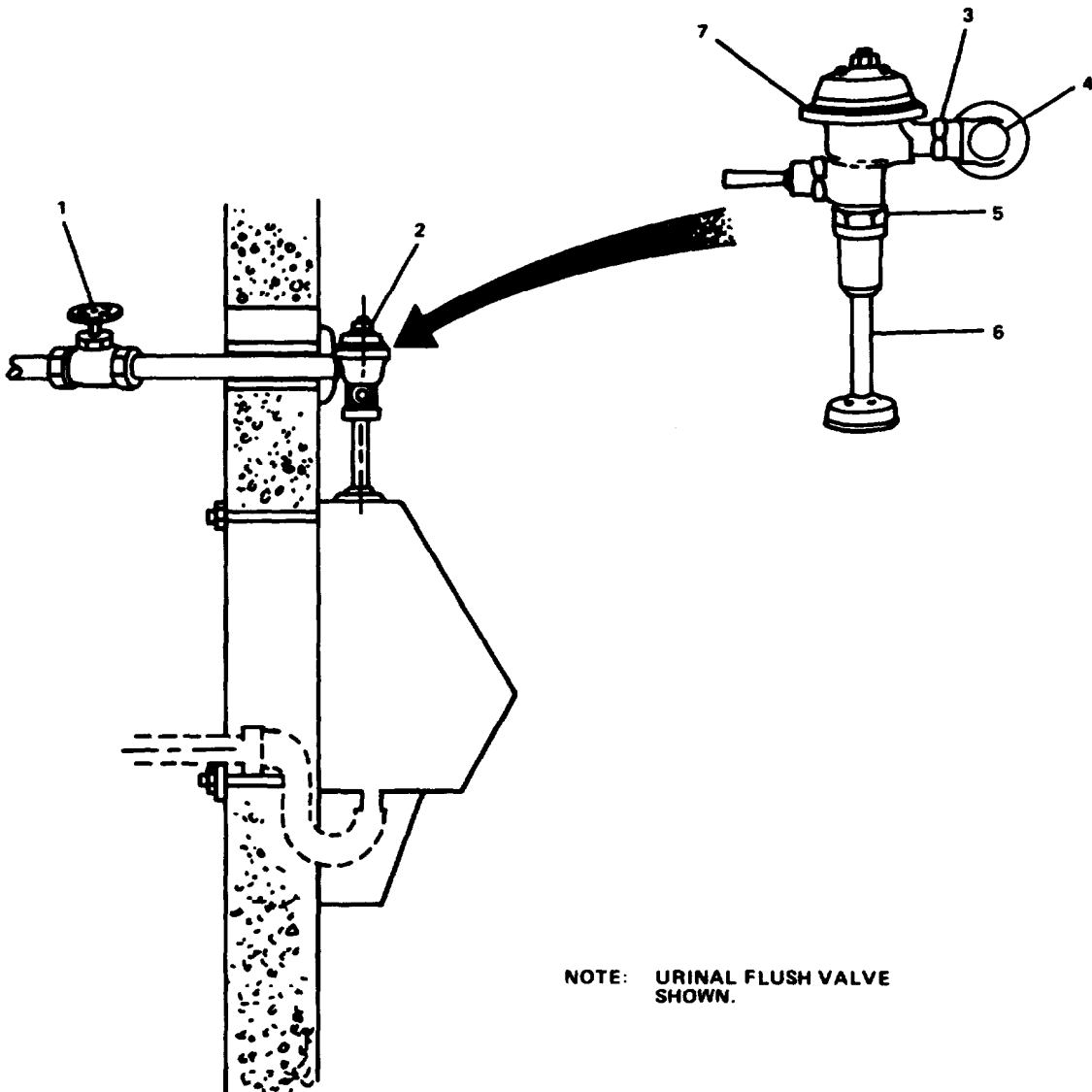
NOTE

Operate flush mechanism to relieve water pressure before removing valve.

- b. Remove flush valve (2) as follows:
  - (1) Loosen nut (3) and remove elbow (4) from supply piping.
  - (2) Loosen nut (5) and remove valve (7) from pipe (6).

**REPAIR**

Repair at this level of maintenance is by replacement of flush valve (2).



NOTE: URINAL FLUSH VALVE SHOWN.

FIGURE 2-258. Repair Flush Valves (Typical).

**REPLACEMENT**

NOTE

Apply teflon tape to all threaded connections prior to assembly.

- a. Position valve (7) on pipe (6) and secure using nut (5), but do not tighten.
- b. Install elbow (4) in supply piping.
- c. Connect valve (7) to elbow (4) using nut (3).
- d. Tighten all connections.
- e. Open fresh water supply valve (1).
- f. Check flush valve connections for leaks and retighten as necessary.

---

## 2-328. Repair Hot Water Heater. (FIGURE 2-259)

---

This task covers: a. Removal, b. Repair, c. Replacement.

---

### INITIAL SETUP

#### Tools

Tool kit, general mechanic's,  
5180-00-699-5273  
Tool kit, electrician's,  
5180-00-391-1087

#### Equipment Condition

At Ship Service Switchboard set HOT  
WATER HEATER circuit breaker to the  
OFF position. Tag switch "Out of  
Service - Do Not Operate."

#### Materials/Parts

Heating element P/N 6002-80  
Gasket P/N 25109  
Faucet P/N 5257  
Tape teflon, Item 5, Appendix C  
Warning tags, Item 1, Appendix C

---

### WARNING

To prevent burns to personnel from hot water heater, ensure that heater has been turned off 24 hours prior to any work to allow water and parts to cool before performing maintenance.

### REMOVAL

- a. Close hot water supply valve (2).
- b. Close cold water isolation valve (3).
- c. Drain hot water heater (1) through drain faucet (4).
- d. Remove drain faucet (4) from hot water heater (1).
- e. Open hinged access door (5).
- f. Remove heating element (6) and gasket (7) from hot water heater (1).

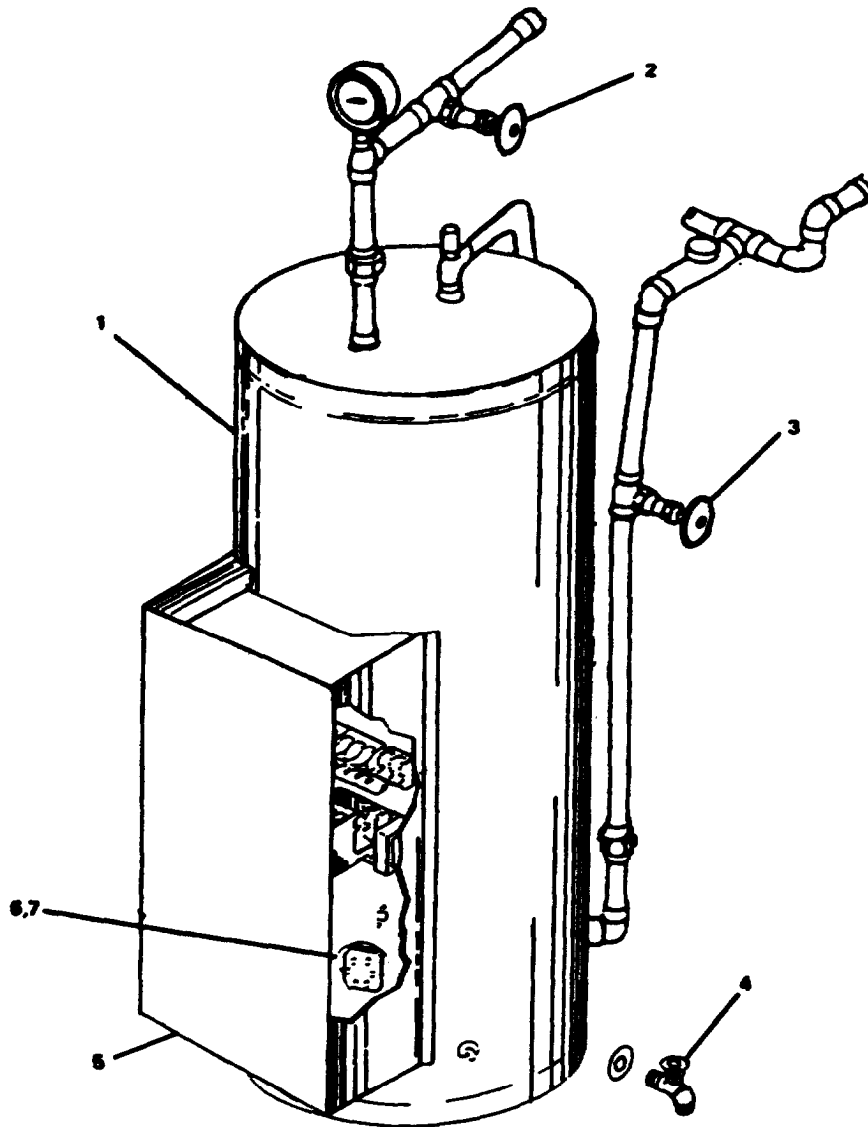


FIGURE 2-259. Repair Hot Water Heater.

**REPAIR**

Repair to the hot water heater at this level of maintenance is by replacement of faucet (4), heating element (6), and gasket (7).

**REPLACEMENT**

- a. Install heating element (6) with gasket (7).

NOTE

Apply teflon tape to all connections prior to assembly.

- b. Install drain faucet (4).

NOTE

Make sure drain faucet is closed.

- c. Open cold water isolation valve (3).
- d. Open hot water supply valve (2).
- e. Remove warning tag and turn on electrical power at main switchboard.
- f. Check hot water heater for leaks and proper operation.
- g. Close hinged access door (5).

MAINTENANCE OF PIPING SYSTEM, BILGE BALLAST AND FIREMAIN

---

2-329. Repair Threaded Valves.

---

This task covers: Repair.

---

**INITIAL SETUP**

**Tools**

Tool kit, general mechanic's,  
5180-00-699-5273

**Materials/Parts**

Piping system, bilge ballast and  
firemain P/N 88529024, refer  
to TM 55-1905-223-24P  
Anti-seize compound, Item 15,  
Appendix C  
Warning tags, Item 1, Appendix C  
Utility pail, Item 13, Appendix C

**Equipment Condition**

At Ship Service Switchboard set  
BILGE/BALLAST circuit breaker to the  
OFF position. Set FIRE PUMP and FIRE  
PUMP 2 circuit breakers to the OFF  
position. Tag switches "Out of  
Service - Do Not Operate."

---

**REPAIR**

Refer to paragraph 2-319 for procedures.



---

**2-330. Repair Flanged Valves.**

---

This task covers: a. Removal, b. Repair, c. Replacement.

---

**INITIAL SETUP****Tools**

Tool kit, general mechanic's,  
5180-00-699-5273

**Materials/Parts**

Piping system, bilge ballast and  
firemain P/N 88529024, refer to  
TN 55-1905-223-24P  
Warning tags, Item 1, Appendix C  
Utility pail, Item 13, Appendix C

**Equipment Condition**

At Ship Service Switchboard set  
BILGE/BALLAST circuit breaker to the  
OFF position. Set FIRE PUMP 1 and  
FIRE PUMP 2 circuit breakers to the  
OFF position. Tag switches "Out of  
Service - Do Not Operate."

**REMOVAL****WARNING**

Use extreme care when disconnecting. Escaping system  
pressure or fluid could cause injury.

**NOTE**

All flanged type valves are replaced in the same manner.

- a. Isolate valve from piping system.
  - (1) Trace inlet piping (1, FIGURE 2-260) to nearest manually operated shutoff valve.
  - (2) Close shutoff valve.
  - (3) Trace outlet piping (6) to nearest manually operated shutoff valve.
  - (4) Close shutoff valve.

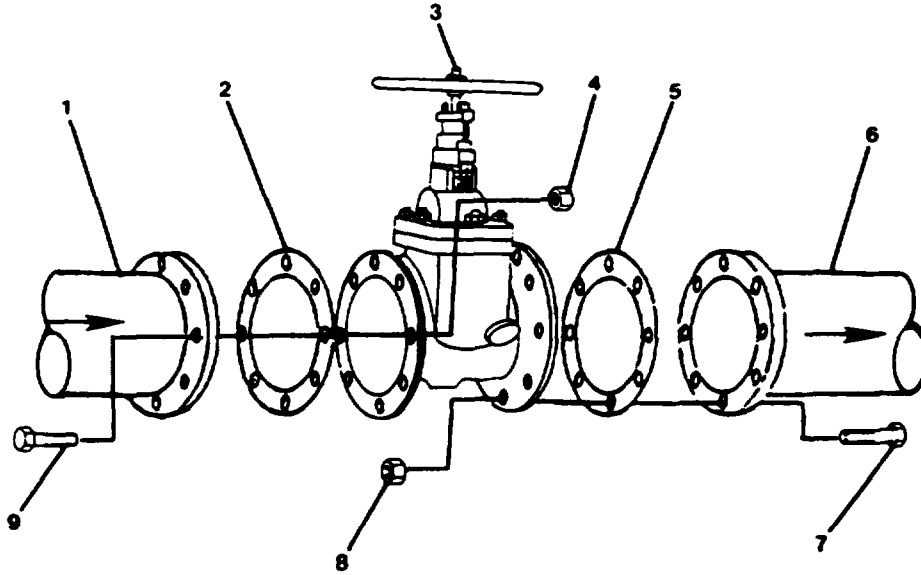


FIGURE 2-260. Repair Flanged Valves (Typical).

b. Remove valve from piping system.

(1) Close valve (3).

**WARNING**

Clean up spills immediately. Spills create an unsafe work area.

(2) Position pail to catch spillage.

**NOTE**

Flanges four to eight inches in diameter use eight bolts; flanges below four inches use four bolts.

(3) Remove outlet flange bolts (7) and nuts (8).

(4) Remove inlet flange bolts (9) and nuts (4).

(5) Remove valve (3) from piping.

(6) Remove flange gaskets (2, 5) from valve (3).

**REPAIR**

Repair at this level of maintenance is by replacement of the flanged valves and gaskets in the bilge ballast and firemain system.

**REPLACEMENT****CAUTION**

To prevent damaging system make sure valves are installed so that the disc will open with the direction of flow.

- a. Install valve in piping system.
  - (1) Position valve (3) in piping with inlet and outlet piping aligned.
  - (2) Hold valve (3) in place and insert gasket (5) between valve outlet flange and outlet piping flange.

**NOTE**

Flanges four to eight inches in diameter use eight bolts; flanges below four inches use four bolts.

- (3) Align gasket boltholes with flange boltholes.
  - (4) Insert bolts (7) through aligned boltholes of gasket and flanges.
  - (5) Thread nuts (8) onto each outlet flange bolt (7) but do not tighten.
  - (6) Position gasket (2) between valve inlet flange and inlet piping flange.
  - (7) Align gasket boltholes with flange boltholes.
  - (8) Insert bolts (9) through aligned boltholes of gasket and flanges.
  - (9) Thread nuts (4) onto each inlet flange bolt (9).
- b. Torque valve.

**CAUTION**

Do not continue to tighten bolts after metal to metal contact is made. Excessive torque may distort flanges.

**NOTE**

Make sure all bolts are tightened evenly and that the gasket and flange faces are aligned.

- (1) Tighten bolts in sequence as shown in FIGURE 2-248.

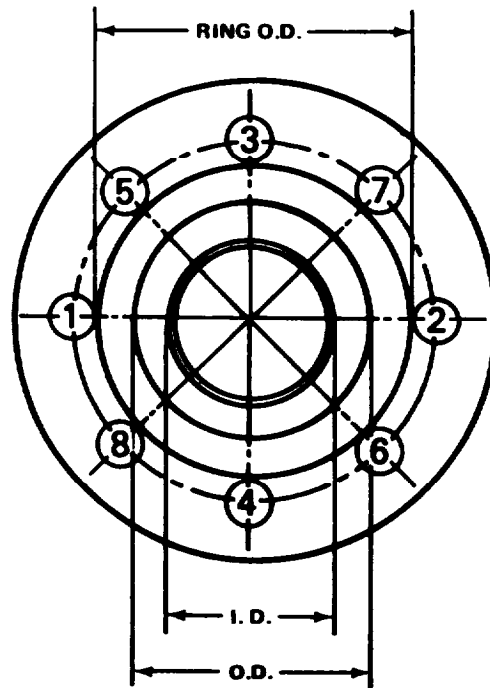


FIGURE 2-261. Torque Sequence Diagram (Typical).

- (2) Tighten bolts until a noticeable increase in torque is felt and when metal to metal contact is made.

c. Operational check.

- (1) Remove warning tags and turn on electrical power at 240 V main switchboard.
- (2) Operate system; refer to TM 55-1905-223-10.
- (3) Check for leaks in system and retighten connections as necessary.

---

## 2-331. Repair Butterfly Valves.

---

This task covers: a. Removal, b. Repair, c. Replacement.

---

### INITIAL SETUP

#### Tools

Tool kit, general mechanic's,  
5180-00-699-5273

#### Materials/Parts

Piping system, bilge ballast and  
firemain P/N 88529024, refer to  
TM 55-1905-223-24P  
Warning tags, Item 1, Appendix C  
Utility pail, Item 13, Appendix C

#### Equipment Condition

At Ship Service Switchboard set  
BILGE/BALLAST circuit breaker to the  
OFF position. Set FIRE PUMP 1 and  
FIRE PUMP 2 circuit breakers to the  
OFF position. Tag switches "Out of  
Service - Do Not Operate."

---

### REMOVAL

#### WARNING

Use extreme care when disconnecting. Escaping system  
pressure of fluid could cause injury.

#### NOTE

All butterfly valves are replaced in the same manner.

- a. Isolate valve from piping system.
  - (1) Trace inlet piping (1, FIGURE 2-262) to nearest manually operated shutoff valve.
  - (2) Close shutoff valve.
  - (3) Trace outlet piping (4) to nearest manually operated shutoff valve.
  - (4) Close shutoff valve.

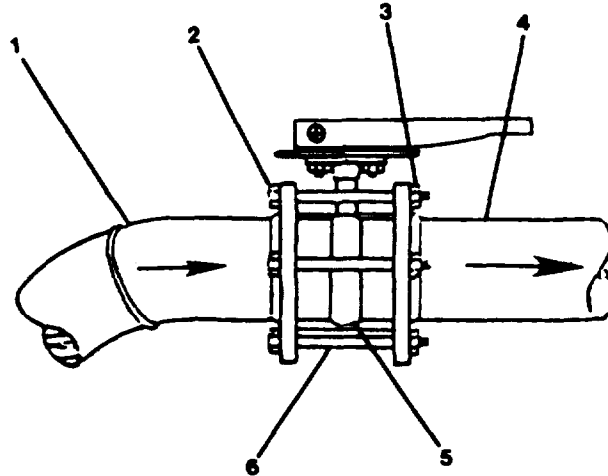


FIGURE 2-262. Repair Butterfly Valves (Typical).

b. Remove valve from piping.

(1) Close butterfly valve (5).

**WARNING**

Clean up spills immediately. Spills create an unsafe work area.

(2) Position pail to catch spillage.

(3) Remove outlet flange nuts (3) from studs (6).

(4) Remove inlet flange nuts (2) from studs (6).

(5) Pull studs (6) from flange boltholes.

(6) Remove butterfly valve (5) from piping.

**REPAIR**

Repair of butterfly valves at this level of maintenance is by replacement of valves (5).

**REPLACEMENT**

- a. Install valve in piping system.

## NOTE

All sealing surfaces must be thoroughly cleaned and checked for signs of damage or corrosion before replacement of valve.

- (1) Clean and inspect sealing surfaces.
  - (2) Position butterfly valve (5) in piping with inlet and outlet piping aligned.
  - (3) Insert studs (6) through flange boltholes.
  - (4) Thread outlet flange nuts (3) on studs (6).
  - (5) Thread inlet flange nuts (2) on studs (6), but do not tighten.
- b. Torque valve.

**CAUTION**

Do not continue to tighten bolts after metal to metal contact is made. Excessive torque may distort flanges.

## NOTE

Make sure all nuts are tightened evenly and that the flange faces are aligned.

- (1) Tighten nuts in sequence as shown in FIGURE 2-263.
  - (2) Tighten nuts until a noticeable increase in torque is felt and when metal to metal contact is made.
- c. Operational check.
    - (1) Remove warning tags and turn on electrical power at 240 V main switchboard.
    - (2) Operate system; refer to TM 55-1905-223-10.
    - (3) Check for leaks in system and retighten connections as necessary.

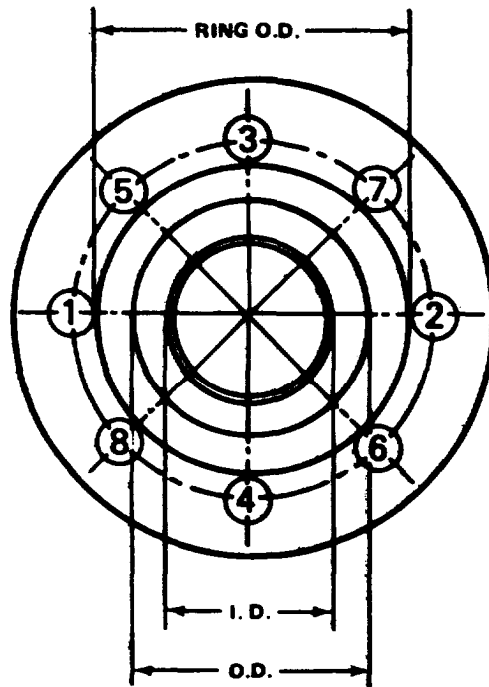


FIGURE 2-263. Torque Sequence Diagram (Typical).



---

**2-332. Repair Rotary Rand Pump. (FIGURE 2-264)**

---

This task covers: a. Removal, b. Repair, c. Replacement.

---

**INITIAL SETUP****Tools**

Tool kit, general mechanic's,  
5180-00-699-5273

**Materials/Parts**

Piping system, bilge ballast and  
firemain P/N 88529024, refer to  
TM 55-1905-223-24P

**Equipment Condition**

At Ship Service Switchboard set  
BILGE/BALLAST circuit breaker to the  
OFF position. Set FIRE PUMP 1 and  
FIRE PUMP 2 circuit breakers to  
the OFF position. Tag switches "Out  
of Service - Do Not Operate."

---

**REMOVAL**

- a. Disconnect suction line (5) and discharge line (1) at unions (2).
- b. Remove bolts (3) securing rotary pump (4) to mounting bracket.
- c. Remove rotary pump (4).

**REPAIR**

Repair at this level of maintenance is by replacement of the rotary hand pump (4).

**REPLACEMENT**

- a. Position rotary pump (4) on mounting bracket.
- b. Secure pump (4) using bolts (3).
- c. Connect discharge line (1) and suction line (5) at unions (2).
- d. Operate hand pump and check for proper operation and leaks.
- e. Retighten connections as necessary.

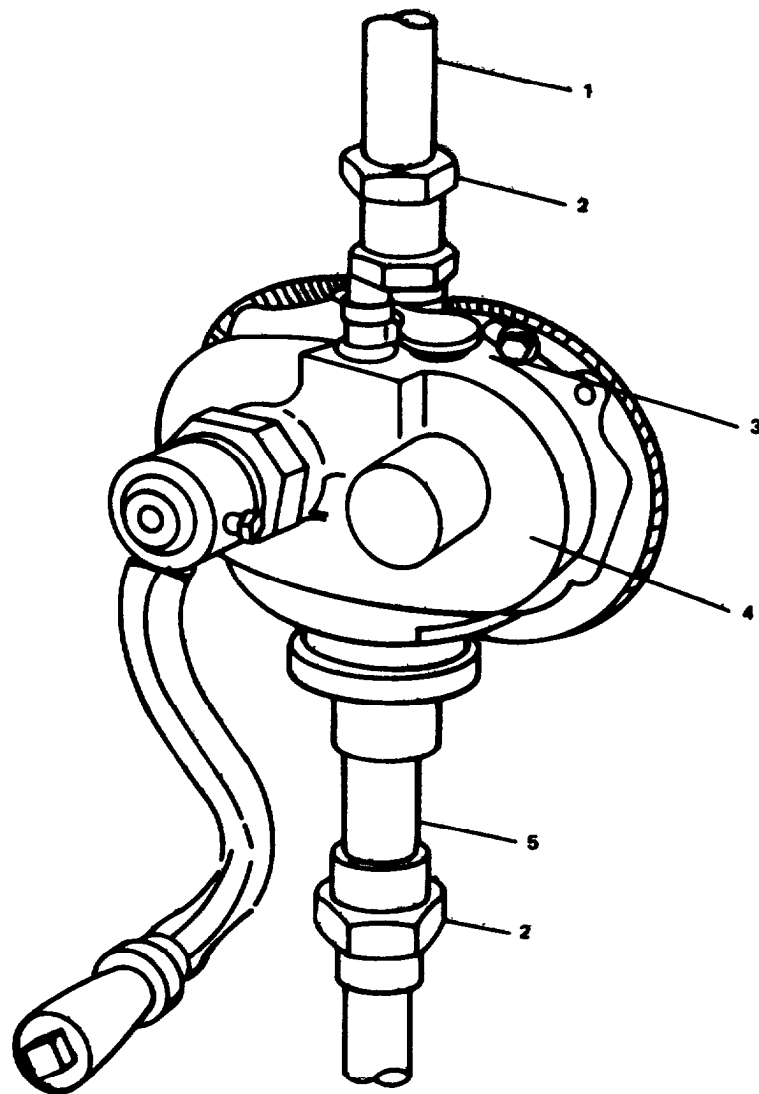


FIGURE 2-264. Repair Rotary Hand Pump, (Typical) .

---

2-333. Repair Fire Hose Assembly. (FIGURE 2-265)

---

This task covers: a. Removal, b. Repair, c. Replacement.

---

### **INITIAL SETUP**

#### **Tools**

Tool kit, general mechanic's,  
5180-00-699-5273

#### **Materials/Parts**

Piping system, bilge ballast and  
firemain P/N 88529024, refer to  
TN 55-1905-223-24P  
Hose and nozzle

#### **Equipment Condition**

At Ship Service Switchboard set  
BILGE/BALLAST circuit breaker to the  
OFF position. Set FIRE PUMP 1 and  
FIRE PUMP 2 circuit breakers to  
the OFF position. Tag switches "Out  
of Service - Do Not Operate."

### **REMOVAL**

#### **WARNING**

To prevent personal injury, make sure shutoff valve is closed.

- a. Open doors to fire station locker (5).
- b. Shut off valve (1).
- c. Disconnect fire hose (3) from shutoff valve (1).
- d. Install cap (6) on shutoff valve (1).
- e. Disconnect fire hose (3) from nozzle (2).
- f. Release belt (4) from fire hose (3).
- g. Remove fire hose (3) from fire station locker (5).

### **REPAIR**

Repair at this level of maintenance is by replacement of nozzle (2) and fire hose (3).

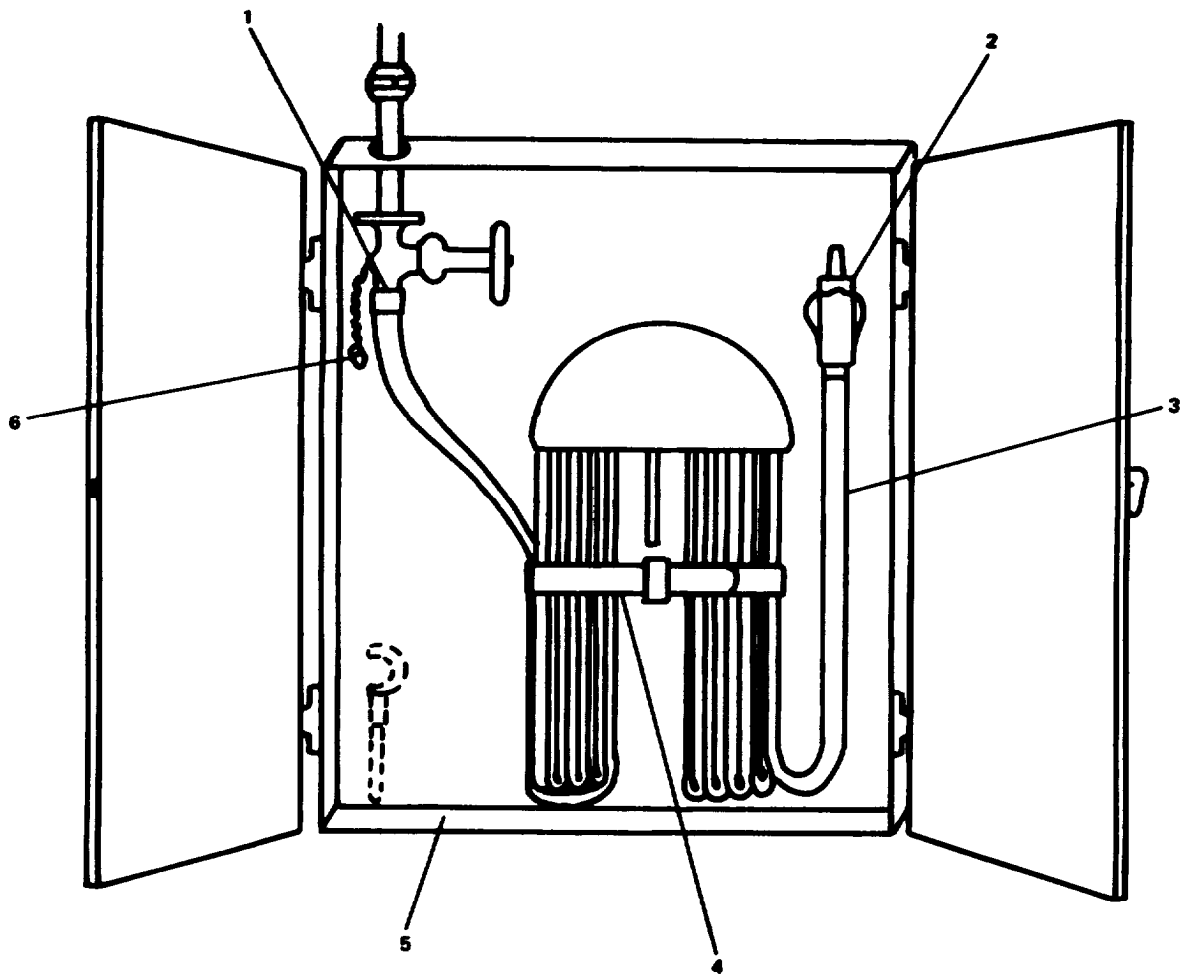


FIGURE 2-265. Repair Fire Hose Assembly.

REPLACEMENT

- a. Remove cap (6) from shutoff valve (1).
- b. Connect new fire hose (3) to shutoff valve (1).
- c. Connect fire hose (3) to nozzle (2).
- d. Open shutoff valve (1) and check fire hose assembly for leaks and proper operation.
- e. Install fire hose (3) in fire station locker (5).
- f. Secure belt (4) on fire hose (3).
- g. Close and secure doors to fire station locker (5).

2-334. Repair Threaded Fittings.

---

This task covers: Repair.

---

**INITIAL SETUP**

**Tools**

Tool kit, general mechanic's,  
5180-00-699-5273

**Materials/Parts**

Piping system, bilge ballast and  
firemain P/N 8529024, refer to  
TN 55-1905-223-24P  
Anti-seize compound, Item 15,  
Appendix C  
Warning tags, Item 1, Appendix C

**Equipment Condition**

At Ship Service Switchboard set  
BILGE/BALLAST circuit breaker to the  
OFF position. Set FIRE PUMP 1 and  
FIRE PUMP 2 circuit breakers to the  
OFF position. Tag switches 'Out of  
Service - Do Not Operate.'

**General Safety Instructions**

**WARNING**

- Ensure system is turned OFF and tagged to prevent operation during maintenance. Generated pressure could cause injury.
- Use extreme care when breaking system connections. Escaping pressure and/or fluids could cause injury.
- Clean up spills immediately. Spills create an unsafe working area.'

---

**REPAIR**

Refer to paragraph 2-320 for procedures.

---

2-335. Repair Piping Gauge Assembly. (FIGURE 2-266)

---

This task covers: a. Removal, b. Repair, c. Replacement.

---

INITIAL SETUP

Tools

Tool kit, general mechanic's,  
5180-00-699-5273

Materials/Parts

Piping system, bilge ballast and fire-  
main P/N 8529024, refer to  
TM 55-1905-223-24P

Pressure gauge, compound  
P/N 33-1035-1075

Pressure gauge, dial indicating  
P/N 33-1935-1075

Teflon tape, Item 5, Appendix C  
Warning tags, Item 1, Appendix C

Equipment Condition

At Ship Service Switchboard set  
BILGE/BALLAST Pump circuit breaker  
to the OFF position. Set FIRE PUMP  
1 and FIRE PUMP 2 circuit breakers  
to the OFF position. Tag switches  
"Out of Service - Do Not Operate."

---

WARNING

Use extreme care when breaking system  
connections. Escaping pressure or fluid  
could cause injury.

REMOVAL

- a. Close isolation valve (1).

---

WARNING

Clean up spills immediately. Spills create  
an unsafe working area.

- b. Disconnect piping gauge assembly (3) by loosening union (2).
- c. Remove piping gauge assembly (3) from isolation valve.
- d. Loosen union (4) and remove pressure gauge (5).

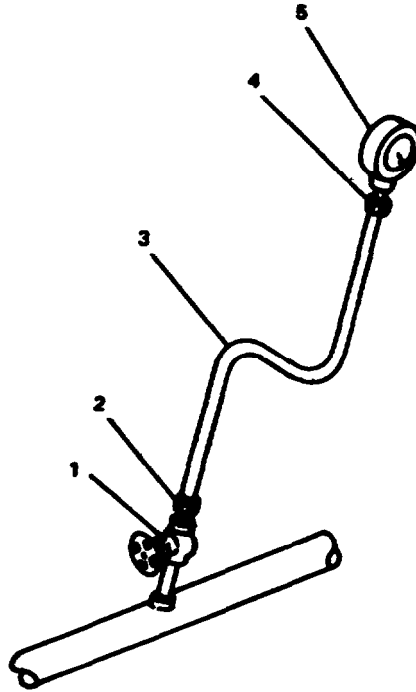


FIGURE 2-266. Repair Piping Gauge Assembly (Typical Single).

### **REPAIR**

Repair at this level of maintenance is by replacement of piping gauge assembly (3) and pressure gauge (5).

### **REPLACEMENT**

#### NOTE

Apply teflon tape to all threaded connections prior to assembly.

- a. Attach pressure gauge (5) to piping gauge assembly (3).
- b. Tighten union (4).
- c. Position piping gauge assembly (3) on isolation valve (1) and tighten union (2).
- d. Remove warning tag and turn on electrical power at 240 V main switchboard.
- e. Operate system; refer to TM 55-1905-223-10.
- f. Check for proper operation and leaks; retighten connections as necessary.



MAINTENANCE OF PIPING SYSTEM, SEA WATER COOLING

2-336. Repair Threaded Valves.

This task covers: Repair.

INITIAL SETUP

Tools

Tool kit, general mechanic's,  
5180-00-699-5273

Materials/Parts

Piping system, sea water cooling  
P/N 8256009, refer to  
TM 55-1905-223-24P

Anti-seize compound, Item 15,  
Appendix C

Warning tags, Item 1, Appendix C  
Utility pail, Item 13, Appendix C

Equipment Condition

Stop the Auxiliary Seawater pump at the Auxiliary Machinery Motor Control Center and set the A.C.S.W. cooling pump circuit breaker to the OFF position. Tag switches "Out of Service - Do Not Operate."

General Safety Instructions

WARNING

- Ensure system is turned OFF and tagged to prevent operation during maintenance. Generated pressure could cause injury.
- Use extreme care when breaking system connections. Escaping pressure and/or fluids could cause injury.
- Clean up spills immediately. Spills create an unsafe working area.

REPAIR

Refer to paragraph 2-319 for procedures.

2-337. Repair Flanged Valves.

---

This task covers: Repair.

---

**INITIAL SETUP**

**Tools**

Tool kit, general mechanic's,  
5180-00-699-5273

**Materials/Parts**

Piping system, sea water cooling  
P/N 8256009, refer to  
TM 55-1905-223-241

Anti-seize compound, Item 15,  
Appendix C

Warning tags, Item 1, Appendix C

Utility pail, Item 13, Appendix C

**Equipment Condition**

Stop the auxiliary seawater pump at the Auxiliary Machinery Motor Control Center and set the A.C.S.W. cooling pump circuit breaker to the OFF position. Tag switches "Out of Service - Do Not Operate."

**General Safety Instructions**

**WARNING**

- Ensure system is turned OFF and tagged to prevent operation during maintenance. Generated pressure could cause injury.
- Use extreme care when breaking system connections. Escaping pressure and/or fluids could cause injury.
- Clean up spills immediately. Spills create an unsafe working area.

---

**REPAIR**

Refer to paragraph 2-330 for procedures.

---

2-338. Repair Butterfly Valves.

---

This task covers: Repair.

---

### INITIAL SETUP

#### Tools

Tool kit, general mechanic's,  
5180-00-699-5273

#### Materials/Parts

Piping system, sea water cooling  
P/N 8256009, refer to  
TM 55-1905-223-24P  
Anti-seize compound, Item 15,  
Appendix C  
Warning tags, Item 1, Appendix C  
Utility pail, Item 13, Appendix C

#### Equipment Condition

Stop the auxiliary seawater pump at the Auxiliary Machinery Motor Control Center and set the A.C.S.W. cooling pump circuit breaker to the OFF position. Tag switches "Out of Service - Do Not Operate."

#### General Safety Instructions

##### WARNING

- Ensure system is turned OFF and tagged to prevent operation during maintenance. Generated pressure could cause injury.
- Use extreme care when breaking system connections. Escaping pressure and/or fluids could cause injury.
- Clean up spills immediately. Spills create an unsafe working area.

---

### REPAIR

Refer to paragraph 2-331 for procedures.

2-339. Repair Threaded Fittings.

---

This task covers: Repair.

---

INITIAL SETUP

Tools

Tool kit, general mechanic's,  
5180-00-699-5273

Materials/Parts

Piping system, sea water cooling  
P/N 8256009, refer to  
TM 55-1905-223-24P  
Anti-seize compound, Item 15,  
Appendix C  
Warning tags, Item 1, Appendix C  
Utility pail, Item 13, Appendix C

Equipment Condition

Stop the auxiliary seawater pump at the Auxiliary Machinery Motor Control Center and set the A.C.S.W. cooling pump circuit breaker to the OFF position. Tag switches "Out of Service - Do Not Operate."

General Safety Instructions

WARNING

- Ensure system is turned OFF and tagged to prevent operation during maintenance. Generated pressure could cause injury.
- Use extreme care when breaking system connections. Escaping pressure and/or fluids could cause injury.
- Clean up spills immediately. Spills create an unsafe working area.

---

REPAIR

Refer to paragraph 2-320 for procedures.

---

2-340. Repair Piping Gauge Assembly. (FIGURE 2-267)

---

This task covers: a. Removal, b. Repair, c. Replacement.

---

### **INITIAL SETUP**

#### **Tools**

Tool kit, general mechanic's,  
5180-00-699-5273

#### **Equipment Condition**

Stop the auxiliary seawater pump at the Auxiliary Machinery Motor Control Center and set the A.C.S.W. cooling pump circuit breaker to the OFF position. Tag switches "Out of Service - Do Not Operate."

#### **Materials/Parts**

Piping gauge assembly P/N 05-2400-0001  
Gauge panel P/N 05-1050-0000  
Gauge, compound, pressure-vacuum  
(30-030 Hg) P/N 33-6490-1075  
Gauge, pressure (0-100 psi)  
P/N 33-1770-1075  
Gauge, pressure (0-15 psi)  
Teflon tape, Item 5, Appendix C  
Warning tags, Item 1, Appendix C

---

### **REMOVAL**

#### **WARNING**

- Use extreme care when breaking system connections. Escaping pressure and/or fluids could cause injury.
  - Clean up spills immediately. Spills create an unsafe working area.
- a. Close isolation valve (8).
  - b. Disconnect piping gauge assembly (10) by loosening union (9).
  - c. Remove nuts (2) and screws (7) from gauge panel (3).
  - d. Remove piping gauge assembly (10) from system.
  - e. Remove pressure-vacuum gauge (4) from piping gauge assembly (10) by loosening union (1).

- f. Remove pressure gauge (5) from piping gauge assembly (10) by loosening union (6).
- g. Remove gauge panel (3) from bulkhead.

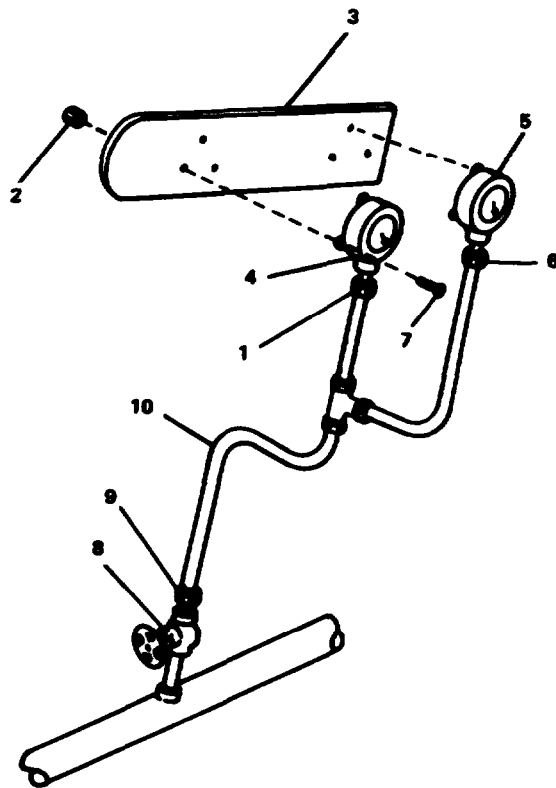


FIGURE 2-267. Repair Piping Gauge Assembly (Typical).

**REPAIR**

Repair at this level of maintenance is by replacement of piping gauge assembly (10), pressure-vacuum gauge (4), pressure gauge (5), and gauge panel (3).

**REPLACEMENT**

**NOTE**

Apply teflon tape to all threaded connections prior to assembly.

- a. Install gauge panel (3) on bulkhead.
- b. Position pressure gauge (5) on piping gauge assembly (10) and tighten union (6).
- c. Position pressure-vacuum gauge (4) on piping gauge assembly (10) and tighten union (1).
- d. Connect piping gauge assembly (10) to system and tighten union (9).

- e. Place pressure gauges in position.
- f. Install screws (7) and nuts (2) on gauge panel (3) and tighten.
- g. Remove warning tags.
- h. Set the A.C.S.W. cooling pump circuit breaker to the ON position.
- i. Press the auxiliary seawater pump START button.
- j. Open isolation valve (8).
- k. Check for proper operation of gauges and leaks in system.

MAINTENANCE OF PIPING SYSTEM, FRESH WATER COOLING

---

2-341. Repair Threaded Fittings.

---

This task covers: Repair.

---

**INITIAL SETUP**

**Tools**

Tool kit, general mechanic's,  
5180-00-699-5273

**Materials/Parts**

Piping system, fresh water cooling  
P/N 8532027, refer to  
TM 55-1905-223-24P  
Warning tags, Item 1, Appendix C  
Anti-seize compound, Item 15,  
Appendix C  
Utility pail, Item 13, Appendix C

**Equipment Condition**

Stop the fresh water cooling pump at the Auxiliary Machinery Motor Control Center and set circuit breaker P205-4 to the OFF position. Tag switches "Out of Service - Do Not Operate."

**General Safety Instructions**

**WARNING**

- Ensure system is turned OFF and tagged to prevent operation during maintenance. Generated pressure could cause injury.
- Use extreme care when breaking system connections. Escaping pressure and/or fluids could cause injury.
- Clean up spills immediately. Spills create an unsafe working area.

---

**REPAIR**

Refer to paragraph 2-320 for procedures.



MAINTENANCE OF PIPING SYSTEM, COMPRESSED AIR
--

---

2-342. Repair Threaded Valves.

---

This task covers: Repair.

---

### **INITIAL SETUP**

#### **Tools**

Tool kit, general mechanic's,  
5180-00-699-5273

#### **Materials/Parts**

Piping system, compressed air  
P/N 8551031, refer to  
TM 55-1905-223-24P  
Anti-seize compound, Item 15,  
Appendix C  
Warning tags, Item 1, Appendix C  
Utility pail, Item 13, Appendix C

#### **Equipment Condition**

At Auxiliary Machinery Motor Control Center, press Air Compressor No. 1 and No. 2 STOP pushbuttons, set circuit breakers to OFF position. Tag switches "Out of Service - Do Not Operate."

#### **General Safety Instructions**

##### **WARNING**

- Ensure system is turned OFF and tagged to prevent operation during maintenance. Generated pressure could cause injury.
- Use extreme care when breaking system connections. Escaping pressure and/or fluids could cause injury.
- Clean up spills immediately. Spills create an unsafe working area.

---

### **REPAIR**

Refer to paragraph 2-319 for procedures.

2-343. Repair Pressure Switch.

---

This task covers: Repair.

---

**INITIAL SETUP**

**Tools**

Tool kit, general mechanic's,  
5180-00-699-5273

**Materials/Parts**

Piping system, compressed air  
P/N 8551031, refer to  
TM 55-1905-223-24P  
Teflon tape, Item 5, Appendix C  
Pressure switch P/N 57-7357-1620  
Pressure switch P/N 57-7357-1820  
Warning tags, Item 1, Appendix C  
Utility pail, Item 13, Appendix C

**Equipment Condition**

At Auxiliary Machinery Motor Control Center, press Air Compressor No. 1 and No. 2 STOP pushbuttons, set circuit breakers to OFF position. Tag switches "Out of Service - Do Not Operate."

**General Safety Instructions**

**WARNING**

- Ensure system is turned OFF and tagged to prevent operation during maintenance. Generated pressure could cause injury.
- Use extreme care when breaking system connections. Escaping pressure and/or fluids could cause injury.
- Clean up spills immediately. Spills create an unsafe working area.

---

**REPAIR**

Refer to paragraph 2-322 for procedures.

2-344. Repair Piping Gauge Assembly.

This task covers: Repair.

**INITIAL SETUP**

Tools

Tool kit, general mechanic's,  
5180-00-699-5273

Materials/Parts

Piping system, compressed air  
P/N 8551031, refer to  
TM 55-1905-223-24P  
Pipe gauge assembly,  
P/N 05-2400-0001  
Gauge assembly P/N 05-2400-0003  
Pressure gauge (0-450 psi)  
P/N 33-2870-1075  
Pressure gauge (0-250 psi)  
P/N 33-2310-1075  
Teflon tape, Item 5, Appendix C  
Utility pail, Item 13, Appendix C

Equipment Condition

At Auxiliary Machinery Motor Control Center, press Air Compressor No. 1 and No. 2 STOP pushbuttons, set circuit breakers to OFF position. Tag switches "Out of Service - Do Not Operate."

General Safety Instructions

**WARNING**

- Ensure system is turned OFF and tagged to prevent operation during maintenance. Generated pressure could cause injury.
- Use extreme care when breaking system connections. Escaping pressure and/or fluids could cause injury.
- Clean up spills immediately. Spills create an unsafe working area.

**REPAIR**

Refer to paragraph 2-335 for procedures.

MAINTENANCE OF PIPING SYSTEM, FIRE MONITOR AND WASHDOWN

---

2-345. Repair Butterfly Valves.

---

This task covers: Repair.

---

INITIAL SETUP

Tools

Tool kit, general mechanic's,  
5180-00-699-5273

Materials/Parts

Piping system, fire monitor and  
washdown P/N 8555032, refer to  
TM 55-1905-223-24P  
Warning tags, Item 1, Appendix C  
Utility pail, Item 13, Appendix C

Equipment Condition

At Ship Service Switchboard Set FIRE  
PUMP 1 and FIRE PUMP 2 circuit  
breakers to the OFF position. Tag  
switches "Out of Service - Do Not  
Operate."

General Safety Instructions

WARNING

- Ensure system is turned OFF and tagged to prevent operation during maintenance. Generated pressure could cause injury.
- Use extreme care when breaking system connections. Escaping pressure and/or fluids could cause injury.
- Clean up spills immediately. Spills create an unsafe working area.

---

REPAIR

Refer to paragraph 2-331 for procedures.

---

**2-346. Repair Threaded Fittings.**

---

This task covers:       a. Repair.

---

**INITIAL SETUP****Tools**

Tool Kit, General Mechanic's,  
5180-00-699-5273

**Materials/Parts**

Piping System, Fire Monitor and Washdown P/N  
8555032, Refer To TM 55-1905-223-24P  
Warning Tags, Item 1, Appendix C  
Utility Pail, Item 13, Appendix C

**Equipment Condition**

At Ship Service Switchboard, Set FIRE PUMP 1 and  
FIRE PUMP 2 Circuit Breakers to the OFF Position.  
Tag switches "Out of Service - Do Not Operate."

**General Safety Instructions****WARNING**

**Ensure system is turned OFF and tagged to  
prevent operation during maintenance.  
Generated pressure could cause injury.**

**Use extreme care when breaking system  
connections. Escaping pressure and/or  
fluids could cause injury.**

**Clean up spills immediately. Spills create an  
unsafe working area.**

---

**REPAIR**

Refer to paragraph 2-320 for procedures.

MAINTENANCE OF PIPING SYSTEM, LUBE OIL TRANSFER/DIRTY OIL DISCHARGE

2-347. Repair Flanged Valves.

This task covers: a. Repair.

INITIAL SETUP

Tools

Tool Kit, General Mechanic's,  
5180-00-699-5273

Materials/Parts

Piping System, Lube Oil Transfer/Dirty Oil Discharge  
P/N 8262011, Refer to TM 55-1905-223-24P  
Warning Tags, Item 1, Appendix C  
Utility Pail, Item 13, Appendix C

Equipment Condition

At the Auxiliary Machinery Motor Control Center,  
Press STOP Pushbutton on Dirty Oil Pump  
Switch and Set Circuit Breaker to the OFF  
Position. Tag Switch, "Out of Service - Do Not  
Operate."

General Safety Instructions

**WARNING**

Ensure system is turned OFF and tagged to  
prevent operation during maintenance.  
Generated pressure could cause injury.

Use extreme care when breaking system  
connections. Escaping pressure and/or fluids  
could cause injury.

Clean up spills immediately. Spills create an  
unsafe working area.

Exercise extreme caution when working with  
flammables.

REPAIR

Refer to paragraph 2-330 for procedures.

---

**2-348. Repair Threaded Valves.**

---

This task covers:           a. Repair.

---

**INITIAL SETUP****Tools**

Tool Kit, General Mechanic's,  
5180-00-699-5273

**Materials/Parts**

Piping System, Lube Oil Transfer/Dirty Oil Discharge  
P/N 8262011, Refer To TM 55-1905-223-24P  
Anti-Seize Compound, Item 15, Appendix C  
Utility Pail, Item 13, Appendix C  
Warning Tags, Item 1, Appendix C

**Equipment Condition**

At the Auxiliary Machinery Motor Control Center.  
Press STOP Pushbutton on Dirty Oil Pump  
Switch and Set Circuit Breaker to the OFF  
Position.  
Tag Switch, "Out of Service - Do Not Operate."

**General Safety Instructions****WARNING**

**Ensure system is turned OFF and tagged to  
prevent operation during maintenance.  
Generated pressure could cause injury.**

**Use extreme care when breaking system  
connections. Escaping pressure and/or fluids  
could cause injury.**

**Clean up spills immediately. Spills create an  
unsafe working area.**

**Exercise extreme caution when working with  
flammables.**

---

**REPAIR**

Refer to paragraph 2-319 for procedures.

## 2-349. Repair Threaded Fittings.

---

This task covers:        a. Repair.

---

### INITIAL SETUP

#### Tools

Tool Kit, General Mechanic's,  
5180-00-699-5273

#### Materials/Parts

Piping System, Lube Oil Transfer/Dirty Oil Discharge  
P/N 8262011, Refer to TM 55-1905-223-24P  
Anti-Seize Compound, Item 15, Appendix C  
Utility Pail, Item 13, Appendix C  
Warning Tags, Item 1, Appendix C

#### Equipment Condition

At the Auxiliary Machinery Motor Control Center.  
Press STOP Pushbutton on Dirty Oil Pump  
Switch and Set Circuit breaker to the OFF  
Position. Tag Switch, "Out of Service - Do Not  
Operate."

#### General Safety Instructions

#### **WARNING**

**Ensure system is turned OFF and tagged to  
prevent operation during maintenance.  
Generated pressure could cause injury.**

**Use extreme care when breaking system  
connections. Escaping pressure and/or fluids  
could cause injury.**

**Clean up spills immediately. Spills create an  
unsafe working area.**

**Exercise extreme caution when working with  
flammables.**

---

### REPAIR

Refer to paragraph 2-320 for procedures.



---

## 2-350. Repair Piping Gauge Assembly.

---

This task covers:           a. Repair.

---

### INITIAL SETUP

#### Tools

Tool Kit, General Mechanic's,  
5180-00-699-5273

#### Materials/Parts

Piping System, Compressed Air P/N 8262011, Refer  
To TM 55-1905-223-24P  
Pipe Gauge Assembly, P/N 05-2400-0001  
Pressure-Vacuum Gauge (30 Vac To 30 PSIG) P/N  
33-1035-1075  
Pressure Gauge (0-200 PSIG)  
P/N 33-2150-1075  
Pressure Gauge (0-60 PSIG)  
P/N 33-1650-1075  
Teflon tape, Item 5, Appendix C  
Utility Pail, Item 13, Appendix C  
Warning Tags, Item 1, Appendix C

#### Equipment Condition

At the Auxiliary Machinery Motor Control Center.  
Press STOP Pushbutton On Dirty Oil Pump  
Switch And Set Circuit Breaker To The OFF  
Position. Tag Switch, "Out Of Service - Do Not  
Operate."

#### General Safety Instructions

#### **WARNING**

**Ensure system is turned OFF and tagged to  
prevent operation during maintenance.  
Generated pressure could cause injury.**

**Use extreme care when breaking system  
connections. Escaping pressure and/or fluids  
could cause injury.**

**Clean up spills immediately. Spills create an  
unsafe working area.**

**Exercise extreme caution when working with  
flammables.**

---

### REPAIR

Refer to paragraph 2-335 for procedures.

MAINTENANCE OF PIPING SYSTEM, HYDRAULIC

---

2-351. Repair Threaded Valves.

---

This task covers: a. Repair.

---

INITIAL SETUP

Tools

Tool Kit, General Mechanic's,  
5180-00-699-5273

General Safety Instructions

WARNING

Materials/Parts

Piping System, Hydraulic P/N 8556010,  
Refer to TM 55-1905-223-24P  
Warning Tags, Item 1, Appendix C  
Utility Pail, Item 13, Appendix C  
Anti-Seize Compound, Item 15, Appendix C

■ Ensure system is turned OFF and tagged to prevent operation during maintenance. Generated pressure could cause injury.

Use extreme care when breaking system connections. Escaping pressure and/or fluids could cause injury.

Clean up spills immediately. Spills create an unsafe working area.

Exercise extreme caution when working with flammables.

---

REPAIR

Refer to paragraph 2-319 for procedures.

---

2-352. Repair Threaded Fittings.

---

This task covers: Repair.

---

INITIAL SETUP

Tools

Tool kit, general mechanic's,  
5180-00-699-5273

Materials/Parts

Piping system, hydraulic P/N 8556010,  
refer to TM 55-1905-223-24P  
Warning tags, Item 1, Appendix C  
Anti-seize compound, Item 15,  
Appendix C  
Utility pail, Item 13, Appendix C

General Safety Instructions

WARNING

- Ensure system is tagged to prevent operation during maintenance. Generated pressure could cause injury.
- Use extreme care when breaking system connections. Escaping pressure and/or fluids could cause injury.
- Clean up spills immediately. Spills create an unsafe working area.
- Exercise extreme caution when working with flammables.

---

REPAIR

Refer to paragraph 2-320 for procedures.

MAINTENANCE OF PIPING SYSTEM, OILY WATER SEPARATOR

---

2-353. Repair Threaded Valves.

---

This task covers: Repair.

---

**INITIAL SETUP**

**Tools**

Tool kit, general mechanic's,  
5180-00-699-5273

**Equipment Condition**

On Oily Water Separator control panel  
set ON - OFF power switch to OFF.  
Tag switch "Out of Service - Do  
Not Operate."

**Materials/Parts**

Piping system, oily water separator  
P/N 8529025, refer to  
TM 55-1905-223-241  
Warning tags, Item 1, Appendix C  
Anti-seize compound, Item 15,  
Appendix C  
Utility pail, Item 13, Appendix C

**General Safety Instructions**

**WARNING**

- Ensure system is tagged to prevent operation during maintenance. Generated pressure could cause injury.
- Use extreme care when breaking system connections. Escaping pressure and/or fluids could cause injury.
- Clean up spills immediately. Spills create an unsafe working area.

---

**REPAIR**

Refer to paragraph 2-319 for procedures.

---

2-354. Repair Threaded Fittings.

---

This task covers: Repair.

---

**INITIAL SETUP**

**Tools**

Tool kit, general mechanic's,  
5180-00-699-5273

**Materials/Parts**

Piping system, oily water separator  
P/N 8529025, refer to  
TM 55-1905-223-24P  
Warning tags, Item 1, Appendix C  
Anti-seize compound, Item 15,  
Appendix C  
Utility pail, Item 13, Appendix C

**Equipment Condition**

On Oily Water Separator control panel  
set ON - OFF power switch to OFF.  
Tag switch "Out of Service - Do  
Not Operate."

**General Safety Instructions**

**WARNING**

- . Ensure system is tagged to prevent operation during maintenance. Generated pressure could cause injury.
- . Use extreme care when breaking system connections. Escaping pressure and/or fluids could cause injury.
- . Clean up spills immediately. Spills create an unsafe working area.

---

**REPAIR**

Refer to paragraph 2-320 for procedures.

2-355. Repair Piping Gauge Assembly.

---

This task covers: Repair.

---

### INITIAL SETUP

#### Tools

Tool kit, general mechanic's,  
5180-00-699-5273

#### Materials/Parts

Piping system, oily water separator  
P/N 8529025, refer to  
TM 55-1905-223-24P  
Piping gauge assembly  
P/N 05-2400-0001  
Pressure gauge (0-10 psi)  
P/N 33-8503-1075  
Warning tags, Item 1, Appendix C  
Teflon tape, Item 5, Appendix C  
Utility pail, Item 13, Appendix C

#### Equipment Condition

On Oily Water Separator control panel  
set ON - OFF power switch to OFF.  
Tag switch "Out of Service - Do  
Not Operate."

#### General Safety Instructions

##### WARNING

- Ensure system is tagged to prevent operation during maintenance. Generated pressure could cause injury.
- Use extreme care when breaking system connections. Escaping pressure and/or fluids could cause injury.
- Clean up spills immediately. Spills create an unsafe working area.

---

### REPAIR

Refer to paragraph 2-335 for procedures.

<p>MAINTENANCE OF PIPING SYSTEM, FUEL TRANSFER PUMP UNIT ASSEMBLY</p>
---

2-356. Repair Piping Gauge Assembly.

This task covers: Repair.

**INITIAL SETUP**

Tools

Tool kit, general mechanic's,  
5180-00-699-5273

Materials/Parts

Piping system, fuel transfer pump  
unit assembly P/N 8541051, refer to  
TM 55-1905-223-241

Piping gauge assembly  
P/N 05-2400-0001

Pressure gauge (O-30 psi)  
P/N 33-1367-1075

Pressure gauge, pressure-vacuum  
(O-30 psi) P/N 33-6490-1075

Teflon tape, Item 5, Appendix C

Utility pail, Item 13, Appendix C

General Safety Instructions

**WARNING**

- Ensure system is tagged to prevent operation during maintenance. Generated pressure could cause injury.
- Use extreme care when breaking system connections. Escaping pressure and/or fluids could cause injury.
- Clean up spills immediately. Spills create an unsafe working area.
- Exercise extreme caution when working with flammables.

**REPAIR**

Refer to paragraph 2-335 for procedures.

MAINTENANCE OF PIPING SYSTEM, SEWAGE AND PLUMBING

---

2-357. Repair Threaded Valves.

---

This task covers: Repair.

---

INITIAL SETUP

Tools

Tool kit, general mechanic's,  
5180-00-699-5273

Materials/Parts

Piping system, sewage and plumbing  
P/N 8528023, refer to  
TM 55-1905-223-24P  
Warning tags, Item 1, Appendix C  
Anti-seize compound, Item 15,  
Appendix C  
Utility pail, Item 13, Appendix C

Equipment Condition

At Ship Service Switchboard set MISC  
MCHRY POWER PANEL circuit breaker to  
OFF position. At Marine Sanitation  
control module set main circuit  
breaker to OFF position. Tag  
switches "Out of Service - Do Not  
Operate."  
All commodes tagged "Out of Service -  
Do Not Operate."

General Safety Instructions

Ensure system is tagged to prevent  
operation during maintenance.  
Generated pressure could cause  
injury.

---

**WARNING**

- . Toxic and flammable vapors are generated in the sewage system. Provide ventilation from outside source before removing covers, drain plugs, hoses, valves, and fittings. Avoid open flames and prolonged breathing of fumes.
- . Use extreme care when breaking system connections. Escaping pressure and/or fluids could cause injury.
- . Clean up spills immediately with disinfectant. Spills create an unsafe working area.
- . After contact with sewage contaminated equipment, clean yourself with disinfectant soap before performing hand-to-mouth functions such as eating, drinking, smoking, etc.

**REPAIR**

Refer to paragraph 2-319 for procedures.



---

2-358. Repair Flanged Valves.

---

This task covers: Repair.

---

INITIAL SETUP

Tools

Tool kit, general mechanic's,  
5180-00-699-5273

Materials/Parts

Piping system, sewage and plumbing  
P/N 8528023, refer to  
TM 55-1905-223-24P  
Warning tags, Item 1, Appendix C  
Utility pail, Item 13, Appendix C

Equipment Condition

At Ship Service Switchboard set MISC MCHRY POWER PANEL circuit breaker to OFF position. At Marine Sanitation control module set main circuit breaker to OFF position. Tag switches "Out of Service - Do Not Operate."  
All commodes tagged "Out of Service - Do Not Operate."

General Safety Instructions

Ensure system is tagged to prevent operation during maintenance. Generated pressure could cause injury.

---

WARNING

- . Toxic and flammable vapors are generated in the sewage system. Provide ventilation from outside source before removing covers, drain plugs, hoses, valves, and fittings. Avoid open flames and prolonged breathing of fumes.
- . Use extreme care when breaking system connections. Escaping pressure and/or fluids could cause injury.
- . Clean up spills immediately with disinfectant. Spills create an unsafe working area.
- . After contact with sewage contaminated equipment, clean yourself with disinfectant soap before performing hand-to-mouth functions such as eating, drinking, smoking, etc.

REPAIR

Refer to paragraph 2-330 for procedures.

2-359. Repair Threaded Fittings.

---

This task covers: Repair.

---

**INITIAL SETUP**

Tools

Tool kit, general mechanic's,  
5180-00-699-5273

Materials/Parts

Piping system, sewage and plumbing  
P/N 8528023, refer to  
TM 55-1905-223-24P  
Warning tags, Item 1, Appendix C  
Anti-seize compound, Item 15,  
Appendix C  
Utility pail, Item 13, Appendix C

Equipment Condition

At Ship Service Switchboard set MISC  
MCHRY POWER PANEL circuit breaker to  
OFF position. At Marine Sanitation  
control module set main circuit  
breaker to OFF position. Tag  
switches "Out of Service - Do Not  
Operate."  
All commodes tagged "Out of Service -  
Do Not Operate."

General Safety Instructions

Ensure system is tagged to prevent  
operation during maintenance.  
Generated pressure could cause injury.

---

**WARNING**

- . Toxic and flammable vapors are generated in the sewage system. Provide ventilation from outside source before removing covers, drain plugs, hoses, valves, and fittings. Avoid open flames and prolonged breathing of fumes.
- . Use extreme care when breaking system connections. Escaping pressure and/or fluids could cause injury.
- . Clean up spills immediately with disinfectant. Spills create an unsafe working area.
- . After contact with sewage contaminated equipment, clean yourself with disinfectant soap before performing hand-to-mouth functions such as eating, drinking, smoking, etc.

**REPAIR**

Refer to paragraph 2-320 for procedures.

---

2-360. Repair Water Closet. (FIGURE 2-268)

---

This task covers: a. Removal, b. Repair, c. Replacement.

---

**INITIAL SETUP**

**Tools**

Tool kit, general mechanic's,  
5180-00-699-5273

**Materials/Parts**

Piping system, sewage and plumbing  
P/N 8528023, refer to  
TM 55-1905-223-24P

**Equipment Condition**

Flush valve removed (para. 2-347)

**General Safety Instructions**

- Clean up spills immediately with disinfectant. Spills create an unsafe working area.
  - After contact with sewage contaminated equipment, clean yourself with disinfectant soap before performing hand-to-mouth functions such as eating, drinking, smoking, etc.
  - Toxic and flammable vapors are generated in the sewage system. Provide ventilation from outside source before removing covers, drain plugs, hoses, valves, and fittings. Avoid open flames and prolonged breathing of fumes.
- 

**REMOVAL**

- a. Remove nuts (2) and lockwashers (3).
- b. Remove water closet (1).
- c. Remove sealing ring (4).

**REPAIR**

Repair at this level of maintenance is by replacement of the water closet (1).

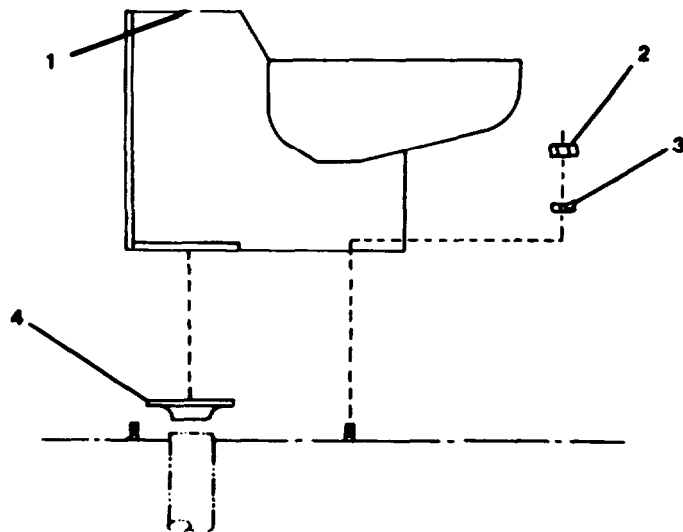


FIGURE 2-268. Repair Water Closet 9725

**REPLACEMENT**

- a. Place sealing ring (4) in position.
- b. Install water closet (1) on deck.

**NOTE**

Make sure deck studs and water closet are properly aligned before securing.

- c. Secure water closet (1) using lockwashers (3) and nuts (2).
- d. Install flush valve (para. 2-327).
- e. Operate water closet and check for leaks around deck sealing ring. Retighten connection as necessary.

---

## 2-361. Repair Urinal. (FIGURE 2-269)

---

This task covers: a. Removal, b. Repair, c. Replacement.

---

### INITIAL SETUP

#### Tools

Tool kit, general mechanic's,  
5180-00-699-5273

#### Materials/Parts

Piping system, sewage and plumbing  
P/N 8528023, refer to  
TM 55-1905-223-24P

#### Equipment Condition

Flush valve removed (para. 2-327)

#### General Safety Instructions

- . Clean up spills immediately with disinfectant. Spills create an unsafe working area.
  - . After contact with sewage contaminated equipment, clean yourself with disinfectant soap before performing hand-to-mouth functions such as eating, drinking, smoking, etc.
  - . Toxic and flammable vapors are generated in the sewage system. Provide ventilation from outside source before removing covers, drain plugs, hoses, valves, and fittings. Avoid open flames and prolonged breathing of fumes.
- 

### REMOVAL

- a. Disconnect drain piping (3) from urinal.
- b. Remove nuts (2) and lockwashers (1) .
- c. Remove urinal (4) from bulkhead.

### REPAIR

Repair at this level of maintenance is by replacement of the urinal (4).

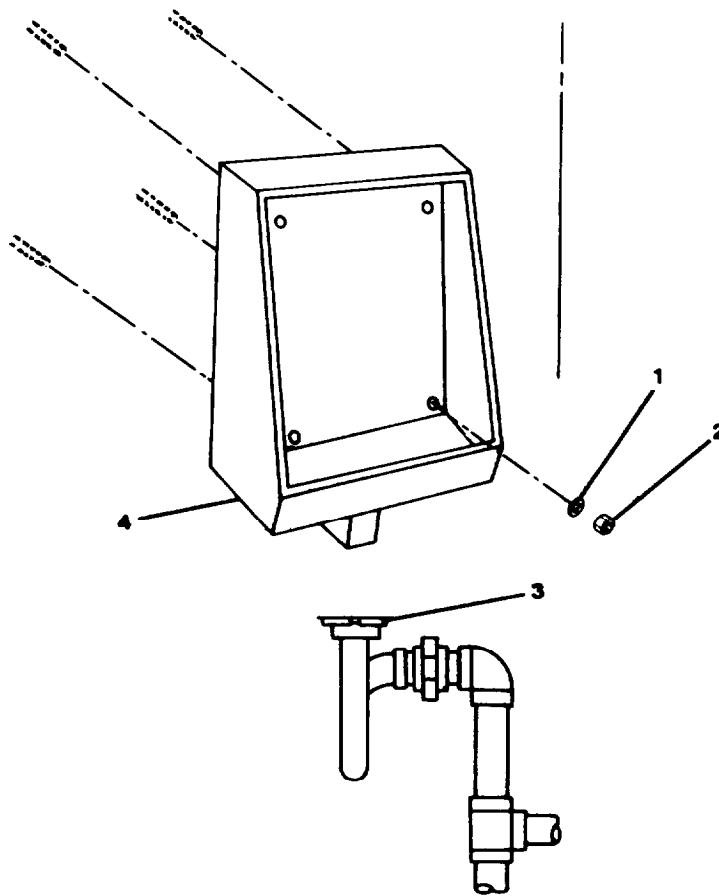


FIGURE 2-269. Repair Urinal.

**REPLACEMENT**

- a. Position urinal (4) on bulkhead.
- b. Install lockwashers (1) and nuts (2).
- c. Connect drain piping (3) to urinal.
- d. Install flush valve (para. 2-327).
- e. Operate urinal and check for leaks around drain piping. Retighten connection as necessary.

---

2-362. Repair Lavatory Basin. (FIGURE 2-270)

---

This task covers: a. Removal, b. Repair, c. Replacement.

---

INITIAL SETUP

Tools

Tool kit, general mechanic's,  
5180-00-699-5273

Materials/Parts

Piping system, sewage and  
plumbing P/N 8528023,  
refer to TM 55-1905-223-24P

Equipment Condition

Faucet removed (para.2-323)

General Safety Instructions

- Clean up spills immediately with disinfectant. Spills create an unsafe working area.
- After contact with sewage contaminated equipment, clean yourself with disinfectant soap before performing hand-to-mouth functions such as eating, drinking, smoking, etc.
- Toxic and flammable vapors are generated in the sewage system. Provide ventilation from outside source before removing covers, drain plugs, hoses, valves, and fittings. Avoid open flames and prolonged breathing of fumes.

---

REMOVAL

- a. Disconnect drain piping (4) from lavatory.
- b. Remove nuts (3) and lockwashers (2).
- c. Remove lavatory (1) from bulkhead.

REPAIR

Repair at this level of maintenance is by replacement of the lavatory (1).

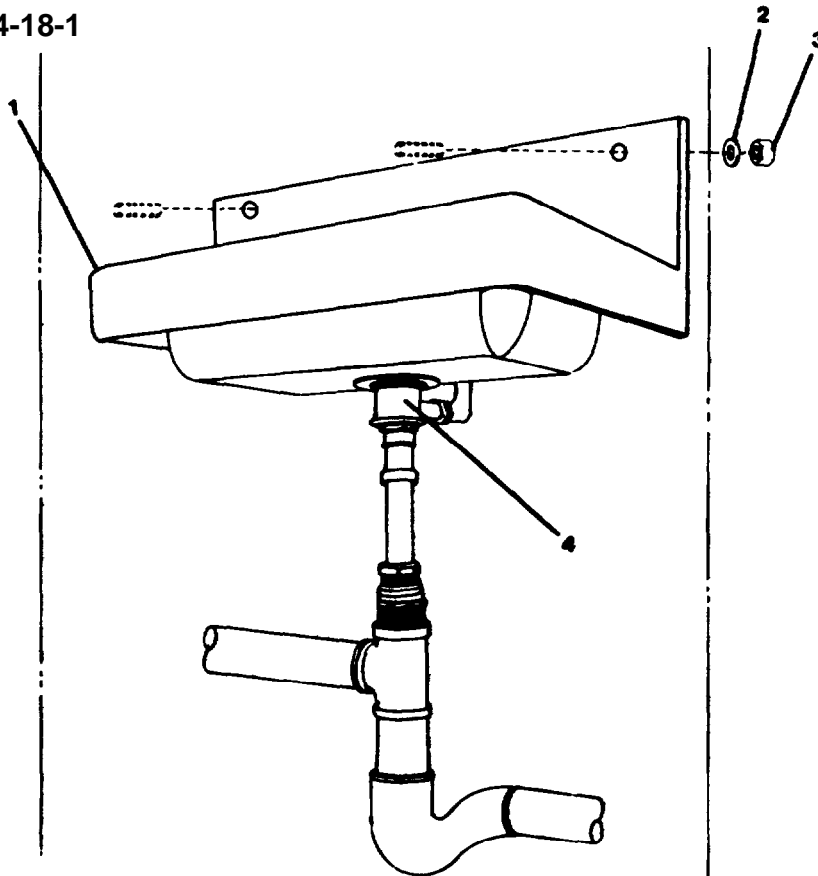


FIGURE 2-270. Repair Lavatory Basin.

**REPLACEMENT**

- a. Position lavatory (1) on bulkhead.
- b. Install lockwashers (2) and nuts (3).
- c. Connect drain piping (4) to lavatory.
- d. Install faucet (para. 2-323).
- e. Operate lavatory and check for leaks. Retighten connections as necessary.



---

2-363. Repair Service Sink. (FIGURE 2-271)

---

This task covers: a. Removal, b. Repair, c. Replacement.

---

**INITIAL SETUP**

Tools

Tool kit, general mechanic's,  
5180-00-699-5273

Materials/Parts

Piping system, sewage and  
plumbing P/N 8528023,  
refer to TM 55-1905-223-24P

Equipment Condition

Faucet removed (para.2-323)

General Safety Instructions

- . Clean up spills immediately with disinfectant. Spills create an unsafe working area.
- . After contact with sewage contaminated equipment, clean yourself with disinfectant soap before performing hand-to-mouth functions such as eating, drinking, smoking, etc.
- . Toxic and flammable vapors are generated in the sewage system. Provide ventilation from outside source before removing covers, drain plugs, hoses, valves, and fittings. Avoid open flames and prolonged breathing of fumes.

---

**REMOVAL**

- a. Disconnect drain piping (2) from service sink.
- b. Remove service sink (1).

**REPAIR**

Repair at this level of maintenance is by replacement of the service sink (1).

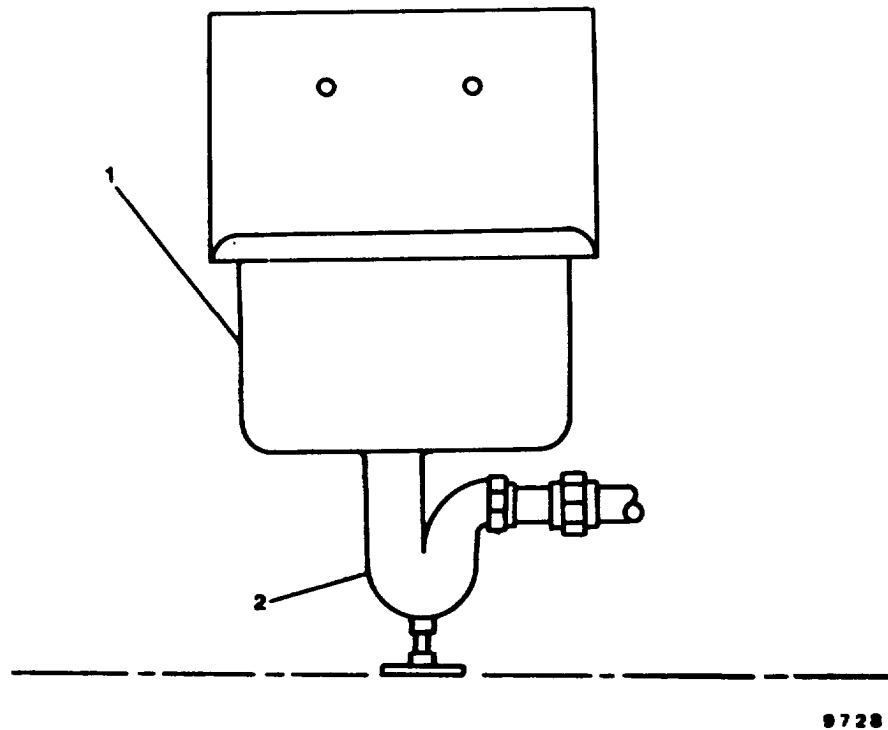


FIGURE 2-271. Repair Service Sink.

REPLACEMENT

- a. Install service sink (1).
- b. Connect drain piping (2) to service sink.
- c. Replace faucet, paragraph 2-323.

MAINTENANCE OF PIPING SYSTEM, BOWTHRUSTER
---

---

2-364. Repair Flanged Valves.

---

This task covers: Repair.

---

### INITIAL SETUP

#### Tools

Tool kit, general mechanic's,  
5180-00-699-5273

#### Materials/Parts

Piping system, bowthruster  
P/N 8561034, refer to TM 55-1905-223-  
24P

Warning tags, Item 1, Appendix C  
Utility pail, Item 13, Appendix C

#### Equipment Condition

At Ship Service Switchboard, set FWD  
DECK MCHRY MCC circuit breaker to OFF  
position. Tag switch "Out of Service  
- Do Not Operate."

#### General Safety Instructions

#### WARNING

- Ensure system is tagged to prevent operation during maintenance. Generated pressure could cause injury.
  - Use extreme care when breaking system connections. Escaping pressure and/or fluids could cause injury.
  - Clean up spills immediately with disinfectant. Spills create an unsafe working area.
  - Exercise extreme caution when working with flammables.
- 

### REPAIR

Refer to paragraph 2-330 for procedures.

2-365. Repair Threaded Fittings.

---

This task covers: Repair.

---

INITIAL SETUP

Tools

Tool kit, general mechanic's,  
5180-00-699-5273

Materials/Parts

Piping system, bowthruster  
P/N 8561034, refer to TM 55-1905-223-  
24P

Warning tags, Item 1, Appendix C  
Anti-seize compound, Item 15,  
Appendix C  
Utility pail, Item 13, Appendix C

Equipment Condition

At Ship Service Switchboard, set FWD  
DECK MCHRY MCC circuit breaker to OFF  
position. Tag switch "Out of Service  
- Do Not Operate."

General Safety Instructions

WARNING

- Ensure system is tagged to prevent operation during maintenance. Generated pressure could cause injury.
- Use extreme care when breaking system connections. Escaping pressure and/or fluids could cause injury.
- Clean up spills immediately with disinfectant. Spills create an unsafe working area.
- Exercise extreme caution when working with flammables.

---

REPAIR

Refer to paragraph 2-320 for procedures.

MAINTENANCE OF PIPING SYSTEM, STEERING GEAR
---

---

2-366. Repair Threaded Valves.

---

This task covers: Repair.

---

### INITIAL SETUP

#### Tools

Tool kit, general mechanic's,  
5180-00-699-5273

#### Materials/Parts

Piping system, steering gear  
P/N 8562035,  
refer to TM 55-1905-223-24P  
Warning tags, Item 1, Appendix C  
Anti-seize compound, Item 15,  
Appendix C  
Utility pail, Item 13, Appendix C

#### Equipment Condition

At the Steering Gear Motor Controller,  
set main power switch to OFF  
position. Tag switch "Out of Service  
- Do Not Operate."

#### General Safety Instructions

#### WARNING

- Ensure system is tagged to prevent operation during maintenance. Generated pressure could cause injury.
  - Use extreme care when breaking system connections. Escaping pressure and/or fluids could cause injury.
  - Clean up spills immediately with disinfectant. Spills create an unsafe working area.
  - Exercise extreme caution when working with flammables.
- 

### REPAIR

Refer to paragraph 2-319 for procedures.

2-367. Repair Threaded Fittings.

---

This task covers: Repair.

---

**INITIAL SETUP**

**Tools**

Tool kit, general mechanic's,  
5180-00-699-5273

**Materials/Parts**

Piping system, steering gear  
P/N 8562035, refer to  
TM 55-1905-223-24P  
Warning tags, Item 1, Appendix C  
Anti-seize compound, Item 15,  
Appendix C  
Utility pail, Item 13, Appendix C

**Equipment Condition**

At the Steering Gear Motor Controller,  
set main power switch to OFF  
position. Tag switch "Cut of Service  
- Do Not Operate."

**General Safety Instructions**

**WARNING**

- Ensure system is tagged to prevent operation during maintenance. Generated pressure could cause injury.
- Use extreme care when breaking system connections. Escaping pressure and/or fluids could cause injury.
- Clean up spills immediately with disinfectant. Spills create an unsafe working area.
- Exercise extreme caution when working with flammables.

---

**REPAIR**

Refer to paragraph 2-320 for procedures.

MAINTENANCE OF PIPING SYSTEM, EMERGENCY GENERATOR
---

---

2-368. Repair Threaded Fittings.

---

This task covers: Repair.

---

### INITIAL SETUP

#### Tools

Tool kit, general mechanic's,  
5180-00-699-5273

#### Materials/Parts

Piping system, emergency generator  
P/N 8310013, refer to  
TM 55-1905-223-24P  
Warning tags, Item 1, Appendix C  
Anti-seize compound, Item 15,  
Appendix C  
Utility pail, Item 13, Appendix C

#### Equipment Condition

At the Steering Gear Motor Controller,  
set main power switch to OFF  
position. Tag switch "Out of Service  
- Do Not Operate."

#### General Safety Instructions

#### WARNING

- . Ensure system is tagged to prevent operation during maintenance. Generated pressure could cause injury.
- . Use extreme care when breaking system connections. Escaping pressure and/or fluids could cause injury.
- . Clean up spills immediately with disinfectant. Spills create an unsafe working area.
- . Exercise extreme caution when working with flammables.

---

### REPAIR

Refer to paragraph 2-320 for procedures.

MAINTENANCE OF PIPING SYSTEM, FOAM PROPORTIONERS

---

2-369. Repair Butterfly Valves.

---

This task covers: Repair.

---

INITIAL SETUP

Tools

Tool kit, general mechanic's,  
5180-00-699-5273

Materials/Parts

Piping system, foam proportioners  
P/N 8529048, refer to  
TM 55-1905-223-24P  
Warning tags, Item 1, Appendix C  
Utility pail, Item 13, Appendix C

Equipment Condition

At Ship Service Switchboard, set FIRE PUMP 1 and FIRE PUMP 2 circuit breakers to the OFF position. Tag switches "Out of Service - Do Not Operate."

General Safety Instructions

**WARNING**

- . Ensure system is tagged to prevent operation during maintenance. Generated pressure could cause injury.
  - . Use extreme care when breaking system connections. Escaping pressure and/or fluids could cause injury.
  - . Clean up spills immediately with disinfectant. Spills create an unsafe working area.
  - . Exercise extreme caution when working with flammables.
- 

**REPAIR**

Refer to paragraph 2-331 for procedures.



---

2-370. Repair Threaded Fittings.

---

This task covers: Repair.

---

---

INITIAL SETUP

Tools

Tool kit, general mechanic's,  
5180-00-699-5273

Materials/Parts

Piping system, foam proportioners  
P/N 8529048, refer to  
TM 55-1905-223-24P  
Warning tags, Item 1, Appendix C  
Anti-seize compound, Item 15,  
Appendix C  
Utility pail, Item 13, Appendix C

Equipment Condition

At Ship Service Switchboard, set FIRE PUMP 1 and FIRE PUMP 2 circuit breakers to the OFF position. Tag switches "Out of Service - Do Not Operate."

General Safety Instructions

**WARNING**

- . Ensure system is tagged to prevent operation during maintenance. Generated pressure could cause injury.
- . Use extreme care when breaking system connections. Escaping pressure and/or fluids could cause injury.
- . Clean up spills immediately with disinfectant. Spills create an unsafe working area.
- . Exercise extreme caution when working with flammables.

---

**REPAIR**

Refer to paragraph 2-320 for procedures.

MAINTENANCE OF PIPING SYSTEM, FIRE PUMP UNIT ASSEMBLY

---

2-371. Repair Threaded Valves.

---

This task covers: Repair.

---

INITIAL SETUP

Tools

Tool kit, general mechanic's,  
5180-00-699-5273

Materials/Parts

Piping system, fire pump unit assembly  
P/N 8529047, refer to  
TM 55-1905-223-24P  
Warning tag, Item 1, Appendix C  
Anti-seize compound, Item 15,  
Appendix C  
Utility pail, Item 13, Appendix C

Equipment Condition

At Ship Service Switchboard, set FIRE PUMP 1 and FIRE PUMP 2 circuit breakers to the OFF position. Tag switches "Out of Service - Do Not Operate."

General Safety Instructions

WARNING

- Ensure system is tagged to prevent operation during maintenance. Generated pressure could cause injury.
- Use extreme care when breaking system connections. Escaping pressure and/or fluids could cause injury.
- Clean up spills immediately with disinfectant. Spills create an unsafe working area.
- Exercise extreme caution when working with flammables.

PAIR

Refer to paragraph 2-319 for procedures.

---

2-372. Repair Butterfly Valves.

---

This task covers: Repair.

---

INITIAL SETUP

Tools

Tool kit, general mechanic's,  
5180-00-699-5273

Materials/Parts

Piping system, fire pump unit assembly  
P/N 8529047, refer to  
TM 55-1905-223-24P  
Warning tags, Item 1, Appendix C  
Utility pail, Item 13, Appendix C

Equipment Condition

At Ship Service Switchboard, set FIRE PUMP 1 and FIRE PUMP 2 circuit breakers to the OFF position. Tag switches "Out of Service - Do Not Operate."

General Safety Instructions

WARNING

- . Ensure system is tagged to prevent operation during maintenance. Generated pressure could cause injury.
- . Use extreme care when breaking system connections. Escaping pressure and/or fluids could cause injury.
- . Clean up spills immediately with disinfectant. Spills create an unsafe working area.
- . Exercise extreme caution when working with flammables.

---

REPAIR

Refer to paragraph 2-331 for procedures.

2-373. Repair Flanged Valves.

---

This task covers: Repair.

---

## INITIAL SETUP

### Tools

Tool kit, general mechanic's,  
5180-00-699-5273

### Materials/Parts

Piping system, fire pump unit assembly  
P/N 8529047, refer to  
TM 55-1905-223-24P  
Warning tags, Item 1, Appendix C  
Utility pail, Item 13, Appendix C

### Equipment Condition

At Ship Service Switchboard, Set FIRE PUMP 1 and FIRE PUMP 2 circuit breakers to the OFF position. Tag switches "Out of Service - Do Not Operate."

### General Safety Instructions

#### WARNING

- . Ensure system is tagged to prevent operation during maintenance. Generated pressure could cause injury.
  - . Use extreme care when breaking system connections. Escaping pressure and/or fluids could cause injury.
  - . Clean up spills immediately with disinfectant. Spills create an unsafe working area.
  - . Exercise extreme caution when working with flammables.
- 

## REPAIR

Refer to paragraph 2-330 for procedures.

**HULLS/MISCELLANEOUS**


---

2-374. Replace/Repair Ladders and Handrails.

---

This task covers: a. Removal, b. Repair, c. Replacement.

---

**INITIAL SETUP****Tools**

Tool kit, general mechanic's,  
5180-00-699-5273  
Tool kit, welder, 5180-00-754-0661  
Torch outfit, cutting and welding  
medium duty, oxygen and acetylene,  
3433-00-357-8116

**Equipment Condition**

"S" Band radar shut down; "X"  
Band radar shut down; and HF  
radio system shut down.  
Tagged "Out of Service - Do Not  
Operate."  
Welding procedures, TM 55-1900-204-24

**Materials/Parts**

Warning tags, Item 1, Appendix C

---

**REMOVAL**

- a. Pilothouse top ladders and handrails. Refer to paragraph 2-375.
- b. Ladders and handrails (02 level). Refer to paragraph 2-376.
- c. Forecastle Deck ladders and handrails. Refer to paragraph 2-377.
- d. Main Deck ladders and handrails. Refer to paragraph 2-378.

**REPAIR**

Refer to replacement parts list of ladders and handrails being serviced.

**REPLACEMENT**

- a. Pilothouse top ladders and handrails. Refer to paragraph 2-375.
- b. Ladders and handrails (02 level). Refer to paragraph 2-376.
- c. Forecastle Deck ladders and handrails. Refer to paragraph 2-377.
- d. Main Deck ladders and handrails. Refer to paragraph 2-378.

2-375. Replace/Repair Pilothouse Top Ladders and Handrails. (FIGURE 2-272)

---

This task covers: a. Removal, b. Repair, c. Replacement.

---

### INITIAL SETUP

#### Tools

Tool kit, general mechanic's,  
5180-00-699-5273  
Tool kit, welder, 5180-00-754-0661  
Torch outfit, cutting and welding  
medium duty, oxygen and acetylene,  
3433-00-357-8116

#### Equipment Condition

"S" Band radar shut down; "X"  
Band radar shut down; and HF  
radio system shut down.  
Tagged "Cut of Service - Do Not  
Operate."  
Welding procedures, TM 55-1900-204-24

#### Materials/Parts

Warning tags, Item 1, Appendix C

---

### REMOVAL

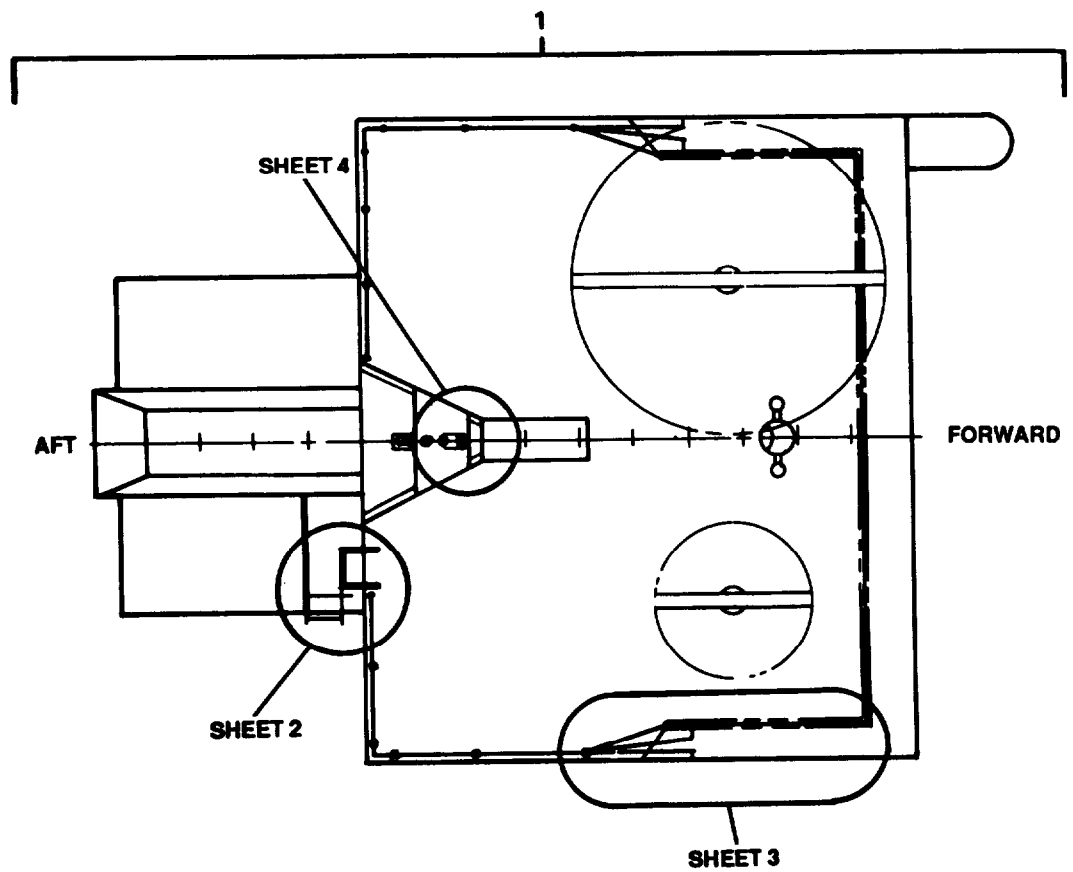
Using a cutting torch, remove pilothouse top ladders and handrails (1, Sheet 1).

### REPAIR

#### NOTE

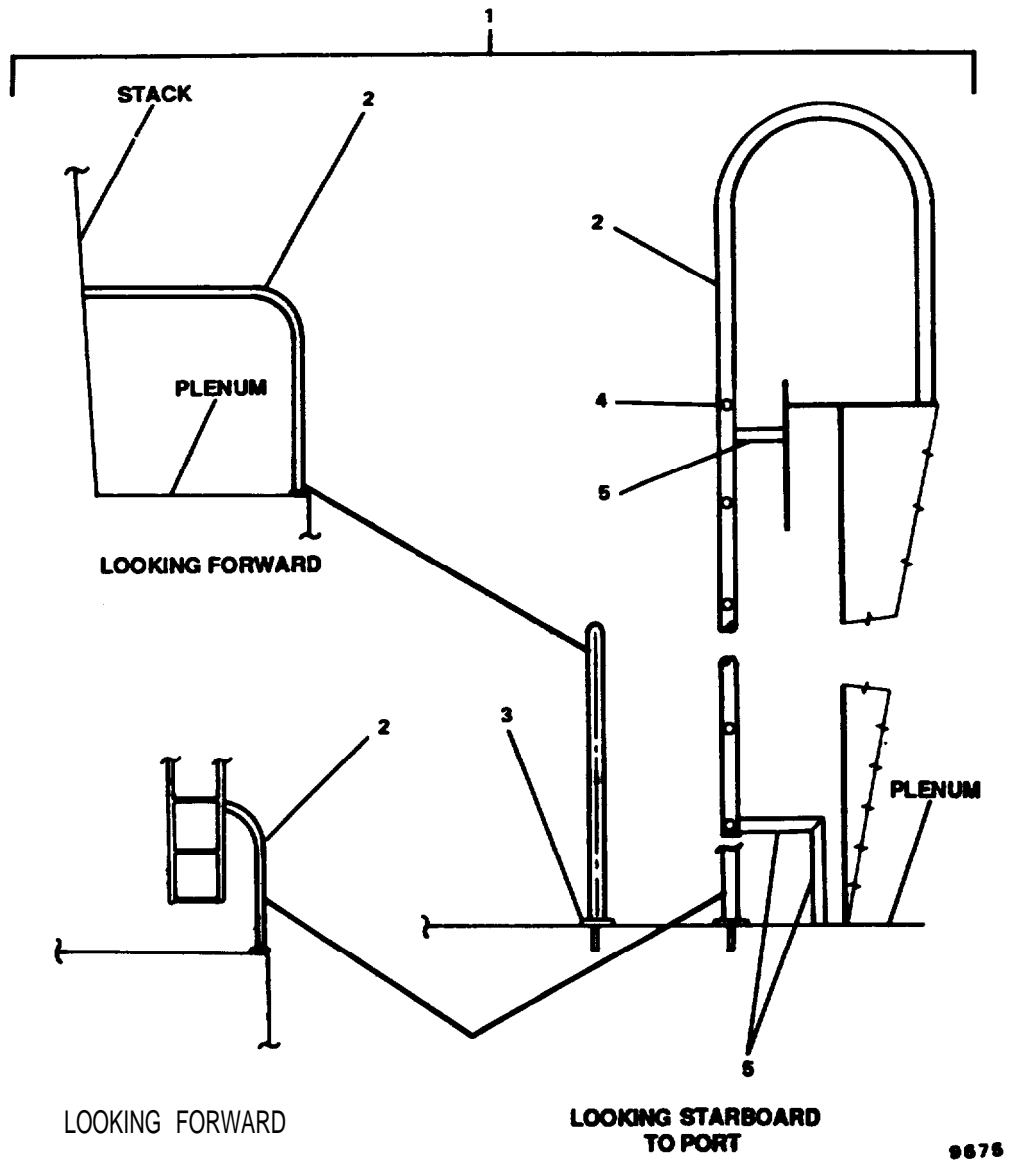
Pilothouse ladders and handrails are welded assemblies and a cutting and welding torch kit is required to repair. All parts must be manufactured from same material. Refer to TM 55-1905-223-24P.

- a. Repair metallic pipe (2, 4, Sheet 2).
- b. Repair plate (3).
- c. Repair flat bar (5, 6, 7, Sheets 2 and 3).
- d. Repair square bar (10, Sheet 4).
- e. Remove machine bolt (9) and self-locking hexagon head nut (8).



9674

FIGURE 2-272. Pilothouse Top Ladders and Handrails (Sheet 1 of 4).



9675

FIGURE 2-272. Pilohouse Top Ladders and Handrails (Sheet 2 of 4)



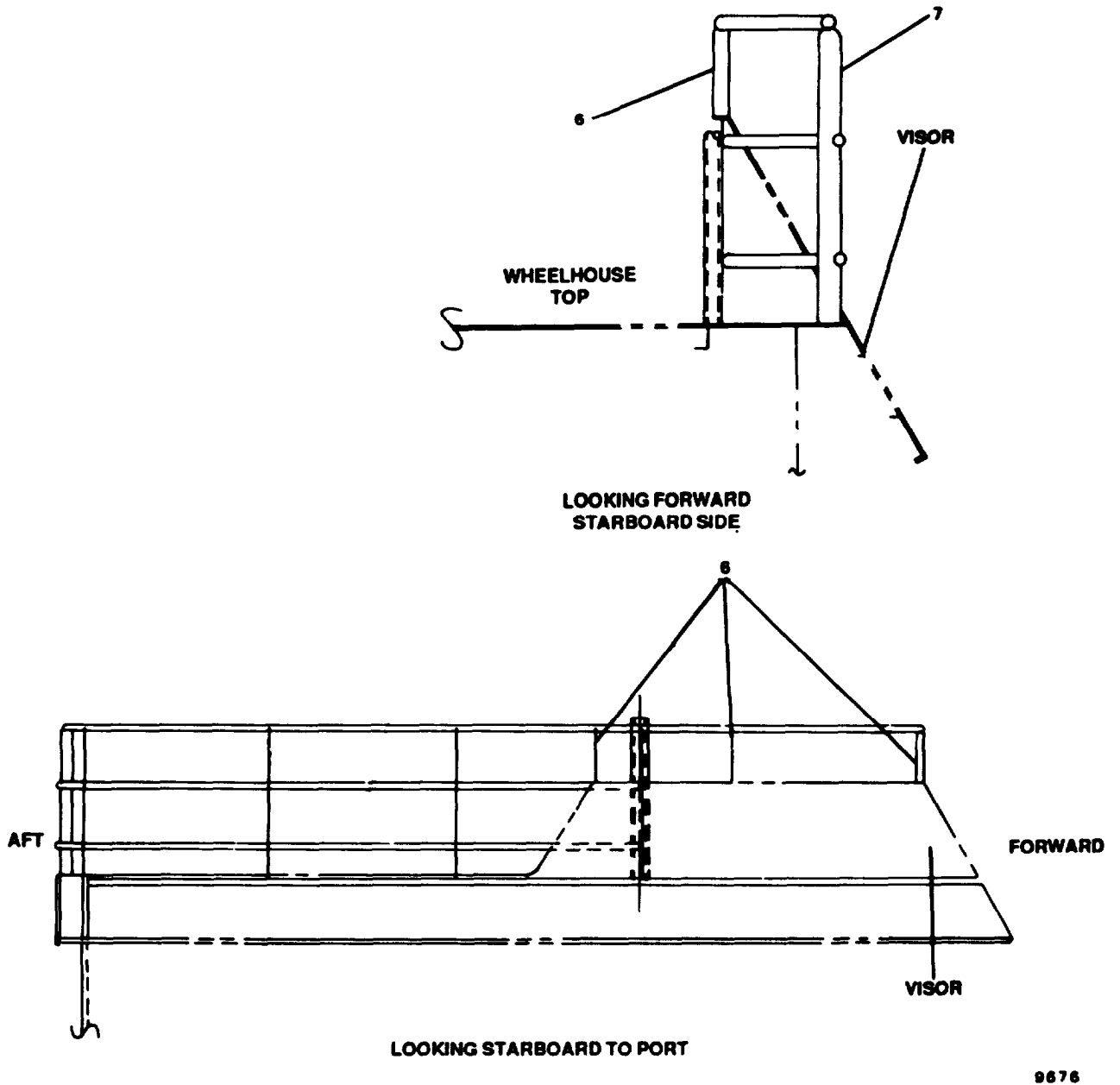
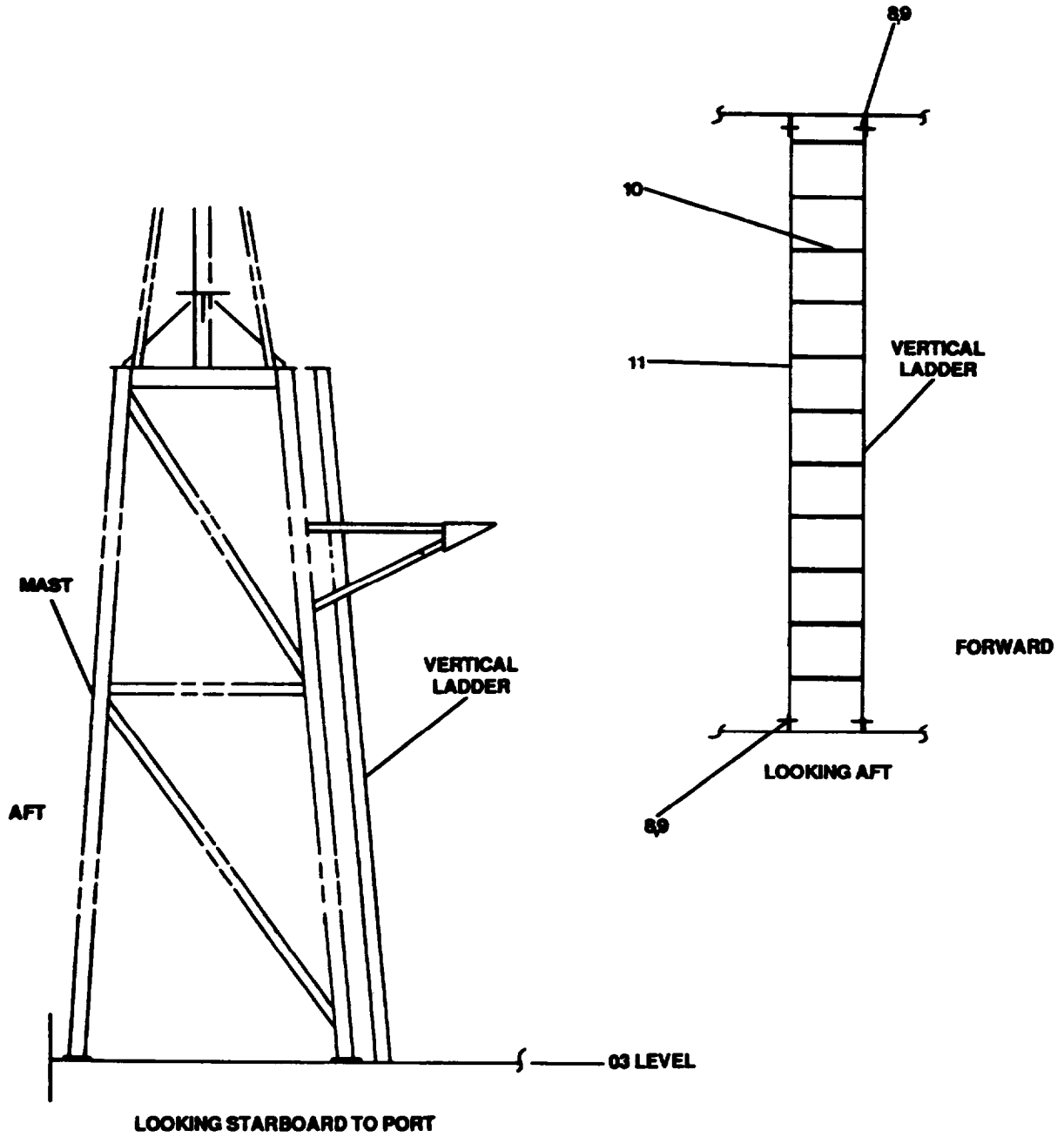


FIGURE 2-272. Pilothouse Top Ladders and Handrails (Sheet 3 of 4).

8676



9677

FIGURE 2-272. Pilothouse Top Ladders and Handrails (Sheet 4 of 4).

f. Remove vertical ladder (11).

**REPLACEMENT**

Using a welding torch, install pilot housetop ladders and handrails (1).

2-376. Replace/Repair 02 Level Ladders and Handrails. (FIGURE 2-273)

---

This task covers: a. Removal, b. Repair, c. Replacement.

---

### INITIAL SETUP

#### Tools

Tool kit, general mechanic's,  
5180-00-699-5273  
Tool kit, welder's  
5180-00-754-0661  
Torch outfit, cutting and  
welding medium duty,  
oxygen and acetylene,  
3433-00-357-8116

#### Equipment Condition

Bridge wings (port and starboard)  
lowered and locked in place. Refer  
to TM 55-1905-223-10.  
Welding procedures, TM 55-1900-204-24

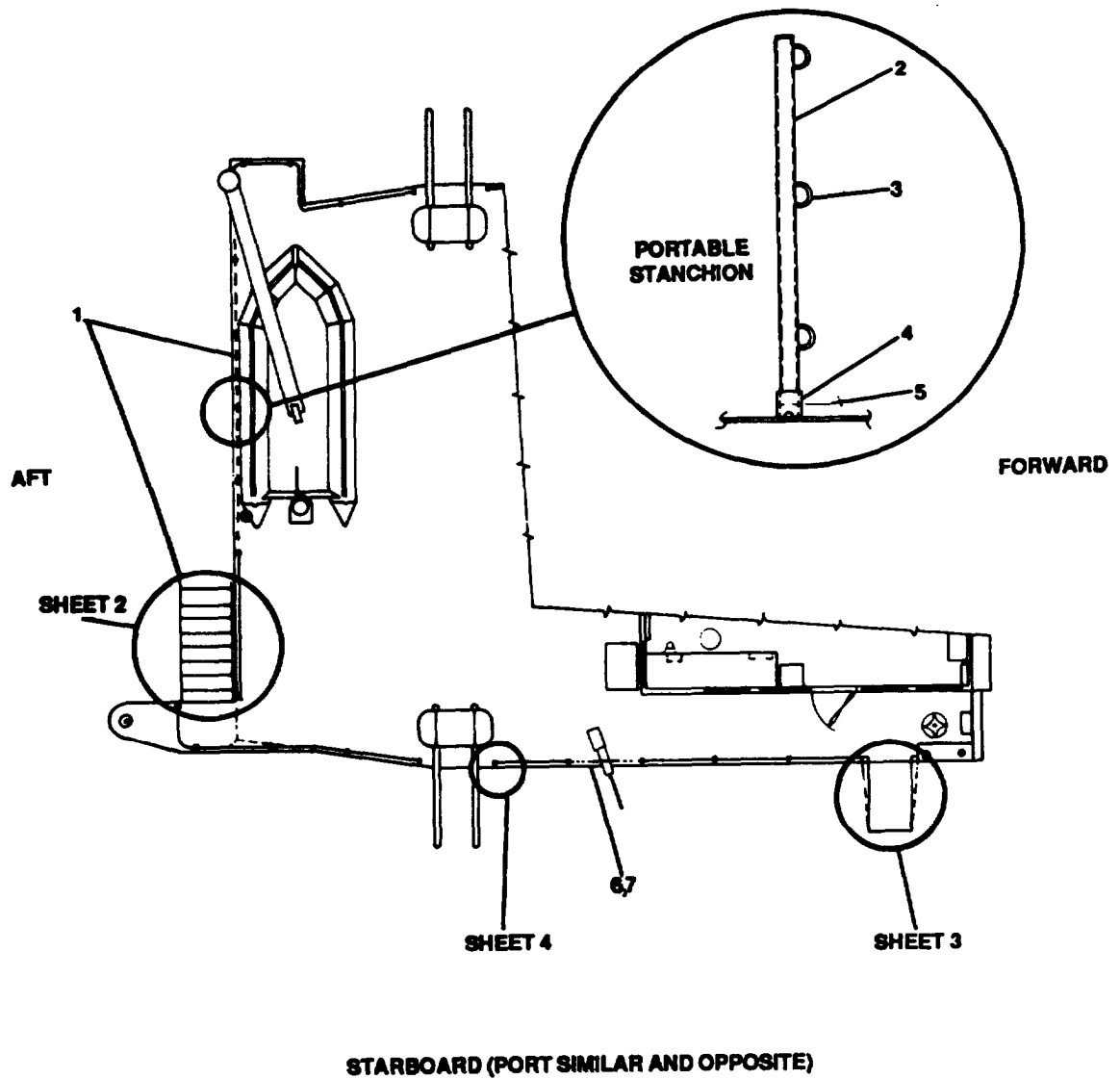
#### Materials/Parts

Warning tags, Item 1, Appendix C  
handrails P/N 8623026-10E

---

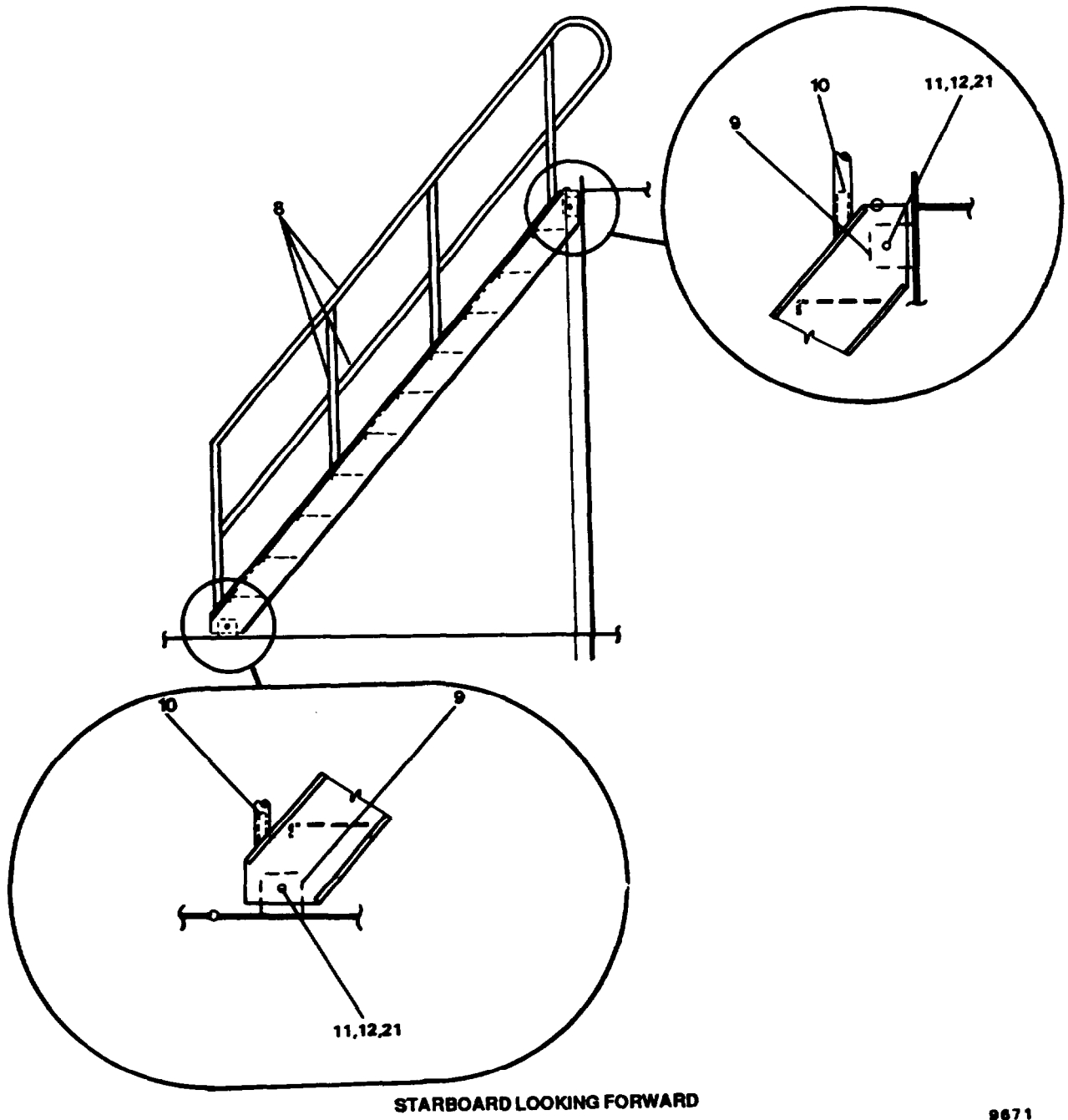
### REMOVAL

- a. Remove quick release pin (5, Sheet 1) and metallic pipe (2).
- b. Remove snap hook (7) and metallic chain (6).
- c. Remove machine bolts (12, Sheet 2), washers (21), and self-locking hexagon nut (11).
- d. Remove ladders and handrails (1, Sheet 1).
- e. Remove turnbuckle (15, Sheet 3), wire rope (16), and thimble (17).
- f. Remove snap hook (18) and metallic chain (19).
- g. Remove anchor shackle (20).
- h. Remove machine bolts (12), and self-locking hexagon nuts (11).
- i. Remove square tubing (22).
- j. Remove quick release pins (5) and metallic pipe (2).



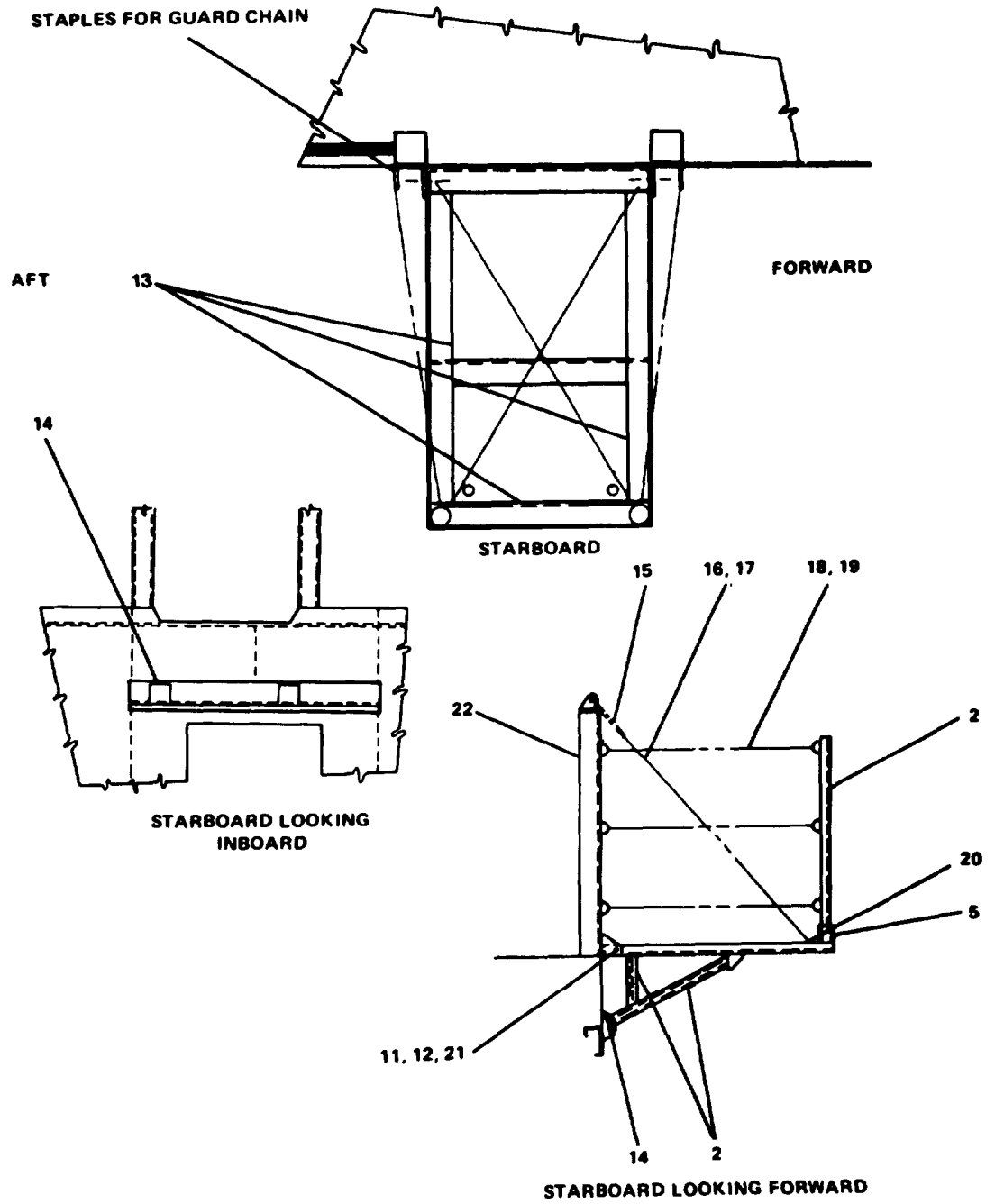
9870

FIGURE 2-273. 02 Level Ladders and Handrails (Sheet 1 of 4)



9671

FIGURE 2-273. 02 Level Ladders and Handrails (Sheet 2 of 4).



9672

FIGURE 2-273. 02 Level Ladders and Handrails (Sheet 3 of 4).

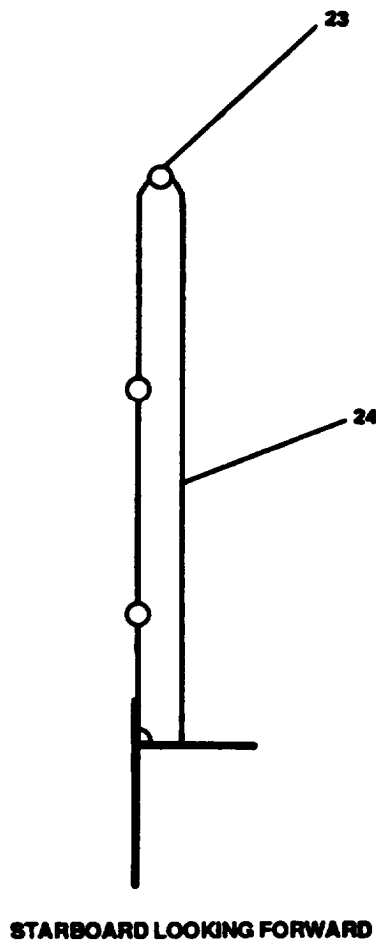


FIGURE 2-273. 02 Level Ladders and Handrails. (Sheet 4 of 4).



**REPAIR****NOTE**

02 level ladders and handrails are welded assemblies and a cutting and welding torch kit is required to repair. All parts must be manufactured from same material. Refer to TM 55-1905-223-24P-4.

- a. Repair metallic pipe (2, Sheet 3).
- b. Repair round bar (3).
- c. Repair metallic pipe (8, Sheet 2).
- d.. Repair flat bar (9).
- e. Repair metallic pipe (10).
- f. Repair angle bar (13, Sheet 3).
- g. Repair plate (14).
- h. Repair metallic pipe (21).
- i. Repair metallic pipe (23, Sheet 4).
- j. Repair flatbar (24).
- k. Repair metallic pipe (2).

**REPLACEMENT**

- a. Install metallic pipe (2, Sheet 1) and quick release pin (5).
- b. Install square tubing (22, Sheet 3).
- c. Install self-locking hexagon nuts (11), machine bolts (12), and metallic pipe (21)
- d. Install shackle anchor (20).
- e. Install metallic chain (19), and snap hook (18).
- f. Install thimble (17), wire rope (16) and turnbuckle (15).
- g. Install ladders and handrails (1, Sheet 1).

2-377. Replace/Repair Forecastle Deck Ladders and Handrails. (FIGURE 2-274)

---

This task covers: a. Removal, b. Repair, c. Replacement.

---

### INITIAL SETUP

#### Tools

Tool kit, general mechanic's,  
5180-00-699-5273  
Tool kit, welder's,  
5180-00-754-0661  
Torch outfit, cutting and  
welding medium duty,  
oxygen and acetylene,  
3433-00-357-8116

#### Equipment Condition

Welding procedures, TM 55-1900-204-24

### Material/Parts

Warning tags, Item 1, Appendix C

---

### REMOVAL

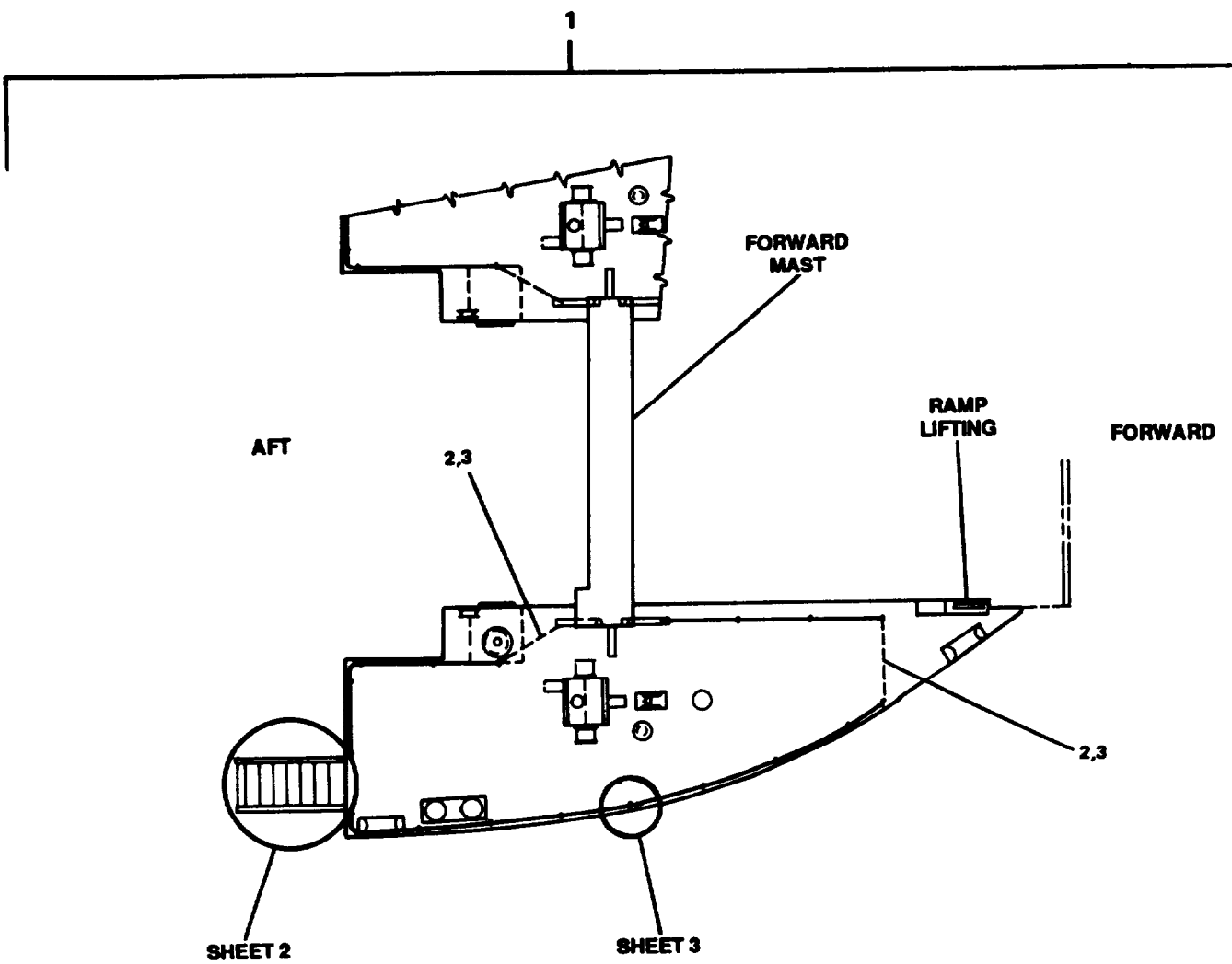
- a. Remove snap hook (3, Sheet 1) and metallic chain (2).
- b. Remove self-locking hexagon nut (7, Sheet 2) and machine bolt (8).
- c. Remove ladders and handrails (1, Sheet 1).

### REPAIR

#### NOTE

Forecastle ladders and handrails are welded assemblies and a cutting and welding torch kit is required. All parts must be manufactured from the same material. Refer to TM 55-1905-223-24P-4.

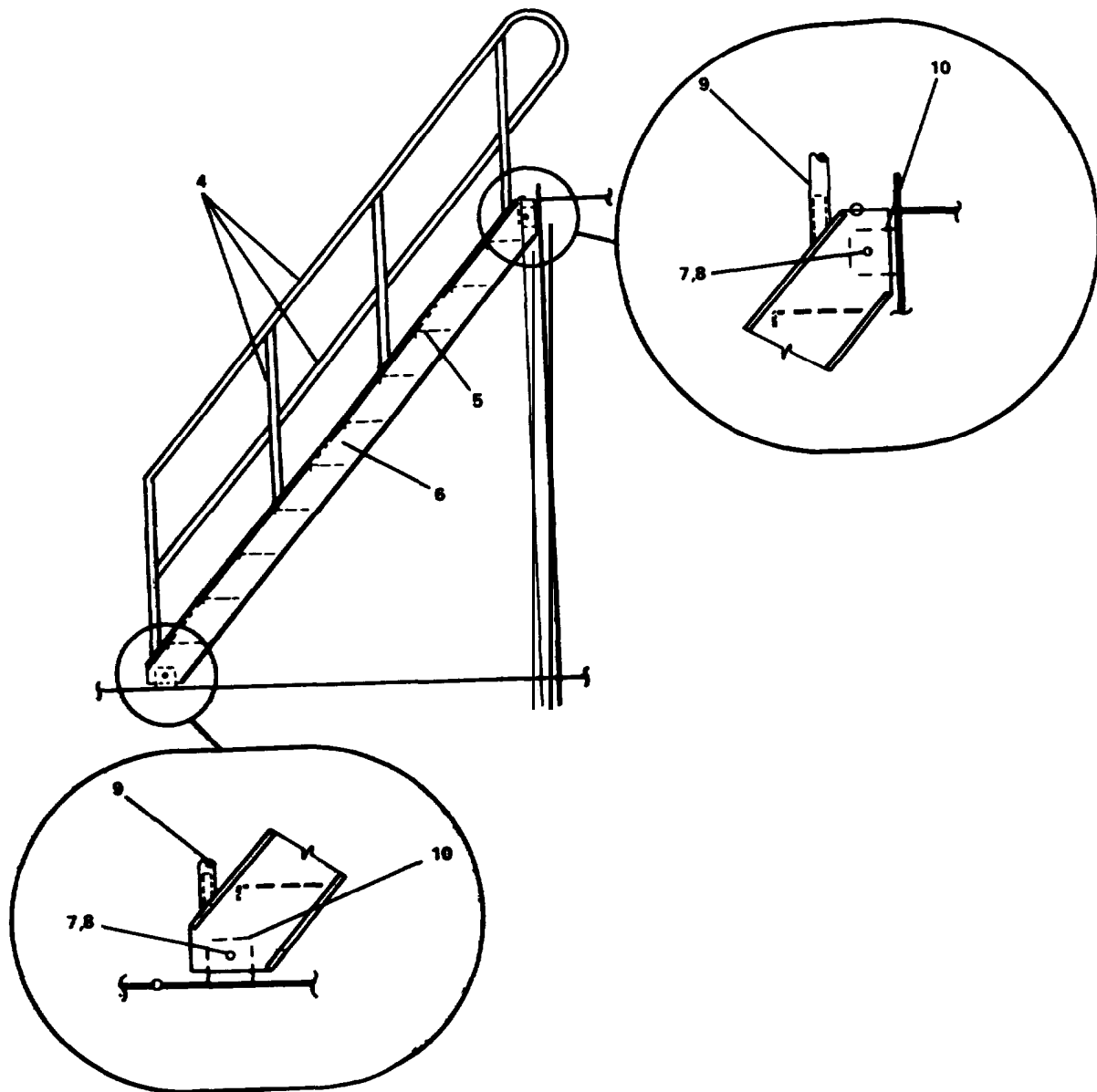
- a. Repair metallic pipe (4, Sheet 2).
- b. Repair diamond plate (5).
- c. Repair channel (6).



02 LEVEL STARBOARD (PORT SIMILAR AND OPPOSITE)

9667

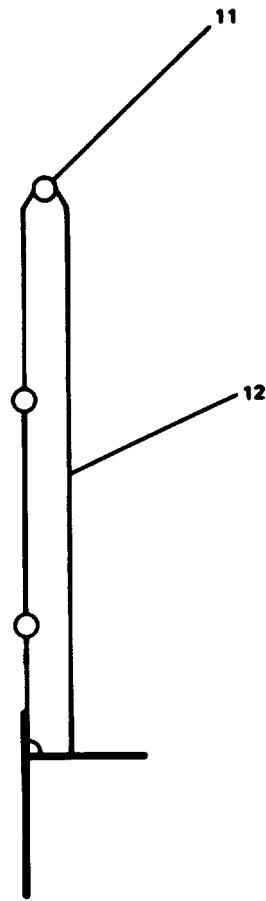
FIGURE 2-274. Forecastle Deck Ladders and Handrails (Sheet 1 of 3).



STARBOARD LOOKING INBOARD

9668

FIGURE 2-274. Forecastle Deck Ladders and Handrails (Sheet 2 of 3).



STARBOARD LOOKING FORWARD

9669

FIGURE 2-274. Forecastle Deck Ladders and Handrails (Sheet 3 of 3).

**TM 55-1905-223-24-18-1**

- d. Repair metallic pipe (9).
- e. Repair flat bar (10).
- f. Repair metallic pipe (11, Sheet 3).
- g. Repair flat bar (12).

**REPLACEMENT**

- a. Install ladders and handrails (1, Sheet 1).
- b. Install machine bolt (8, Sheet 2) and self-locking hexagon nut (7).
- c. Install metallic chain (2, Sheet 1) and snap hook (3).

---

2-378. Replace/Repair Main Deck Ladders and Handrails. (FIGURE 2-275)

---

This task covers: a. Removal, b. Repair, c. Replacement.

---

### INITIAL SETUP

#### Tools

Tool kit, general mechanic's,  
5180-00-699-5273  
Tool kit, welder's,  
5180-00-754-0661  
Torch outfit, cutting and  
welding medium duty,  
oxygen and acetylene,  
3433-00-357-8116

#### Equipment Condition

Welding procedures, TM 55-1900-204-24.

#### Materials/Parts

Warning tags, Item 1, Appendix C

---

### REMOVAL

- a. Remove self-locking hexagon nut (4, Sheet 2) and machine bolt (5).
- b. Remove ladders and handrails (1, Sheet 1).

### REPAIR

#### **NOTE**

Main deck ladders and handrails are welded assemblies and a cutting and welding torch kit is required to repair. All parts must be manufactured from the same material. Refer to TM 55-1905-223-24P-4.

- a. Repair metallic pipe (2, Sheet 2 and 1, Sheet 3).
- b. Repair metallic pipe (3, Sheet 2).
- c. Repair flat bar (6, Sheet 2).
- d. Repair diamond plate (7, Sheet 2 and 6, Sheet 3).

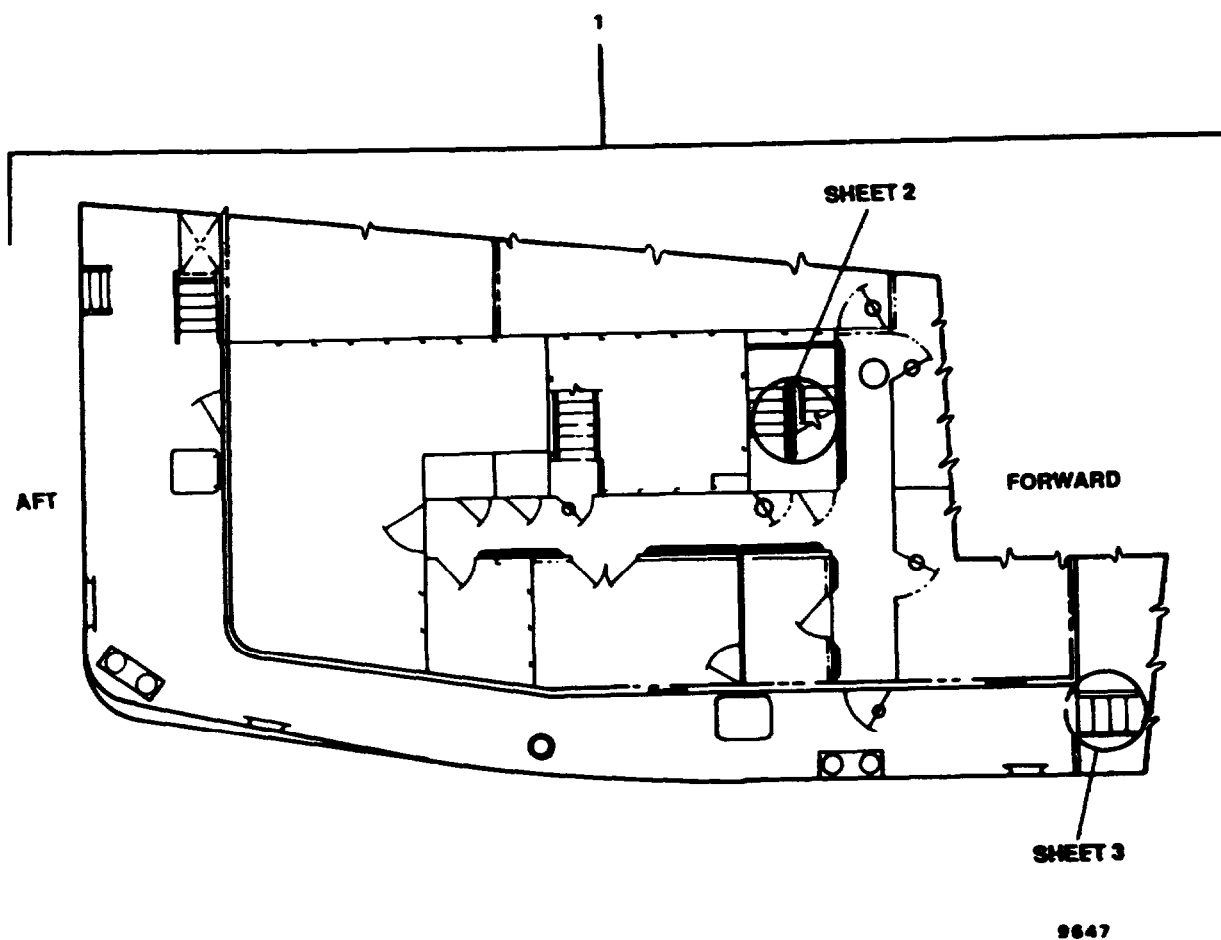
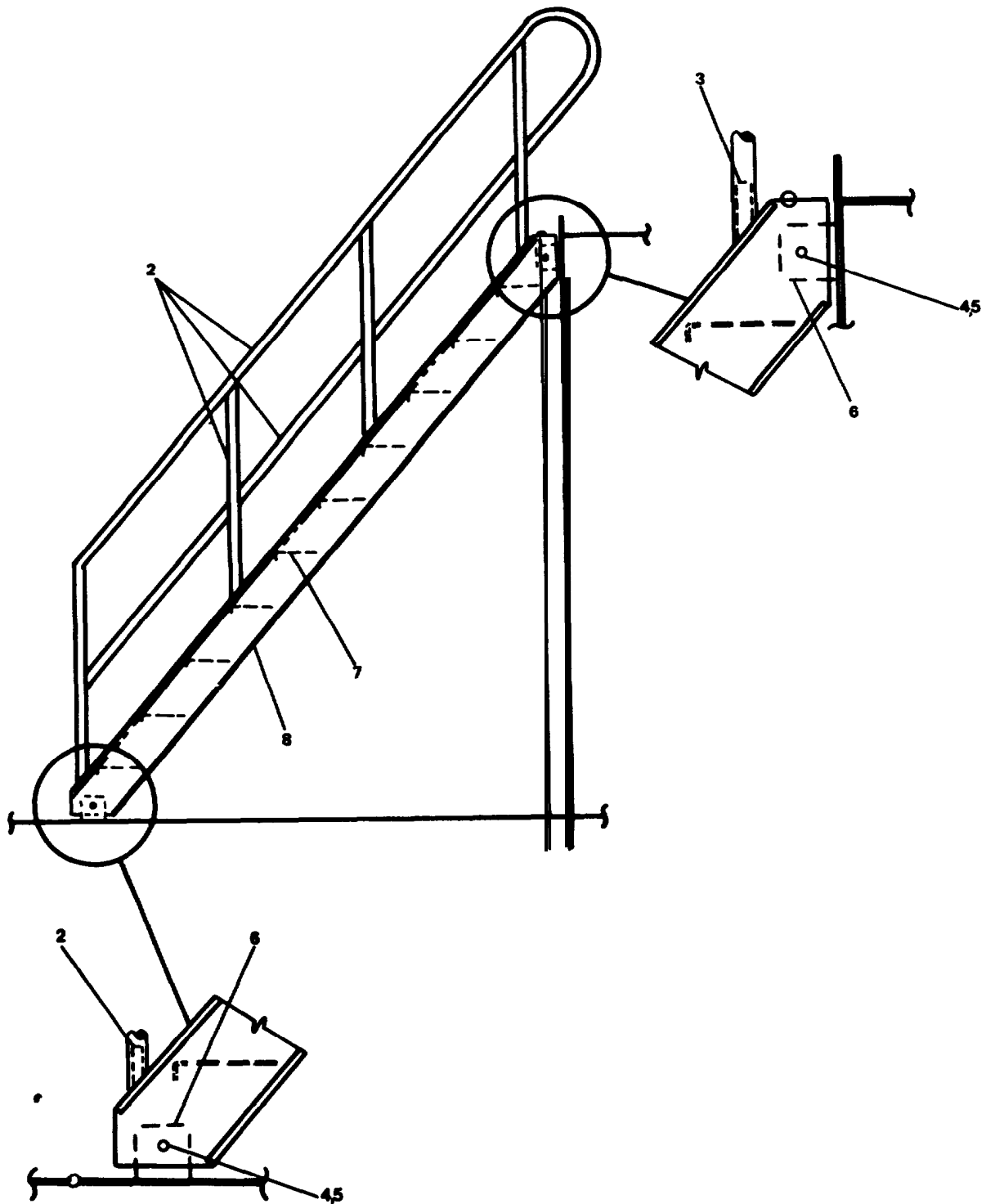


FIGURE 2-275. Main Deck Ladders and Handrails (Sheet 1 of 3).





9648

FIGURE 2-275. Main Deck Ladders and Handrails(Sheet 2 of 3).

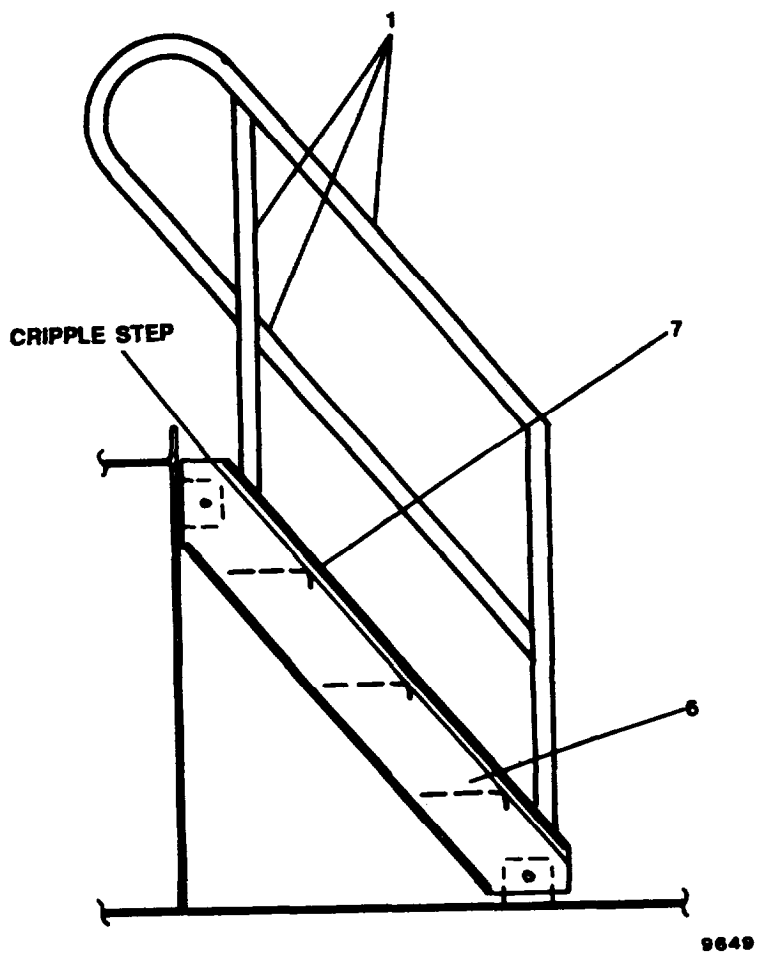


FIGURE 2-275. Main Deck Ladders and Handrails (Sheet 3 of 3).

- e. Repair channel (8, Sheet 2 and 7, Sheet 3).

**REPLACEMENT**

- a. Install ladders and handrails (1, Sheet 1).
- b. Install machine bolts (5, Sheet 2) and self-locking hexagon nut (4).

2-379. Repair Emergency Diesel Generator Day Tank. (FIGURE 2-276)

---

This task covers: a. Removal, b. Replacement.

---

**INITIAL SETUP**

**T o o l s**

Tool kit, general mechanic's,  
5180-00-699-5273

**Materials/Parts**

Rags, Item 14, Appendix C

**Equipment Condition**

Fuel supply and fill valves to day tank closed. Drain valve open to drain day tank, refer to TM 55-1905-223-10. Day tank liquid quantity indicator alarm disconnected.

---

**REMOVAL**

**WARNING**

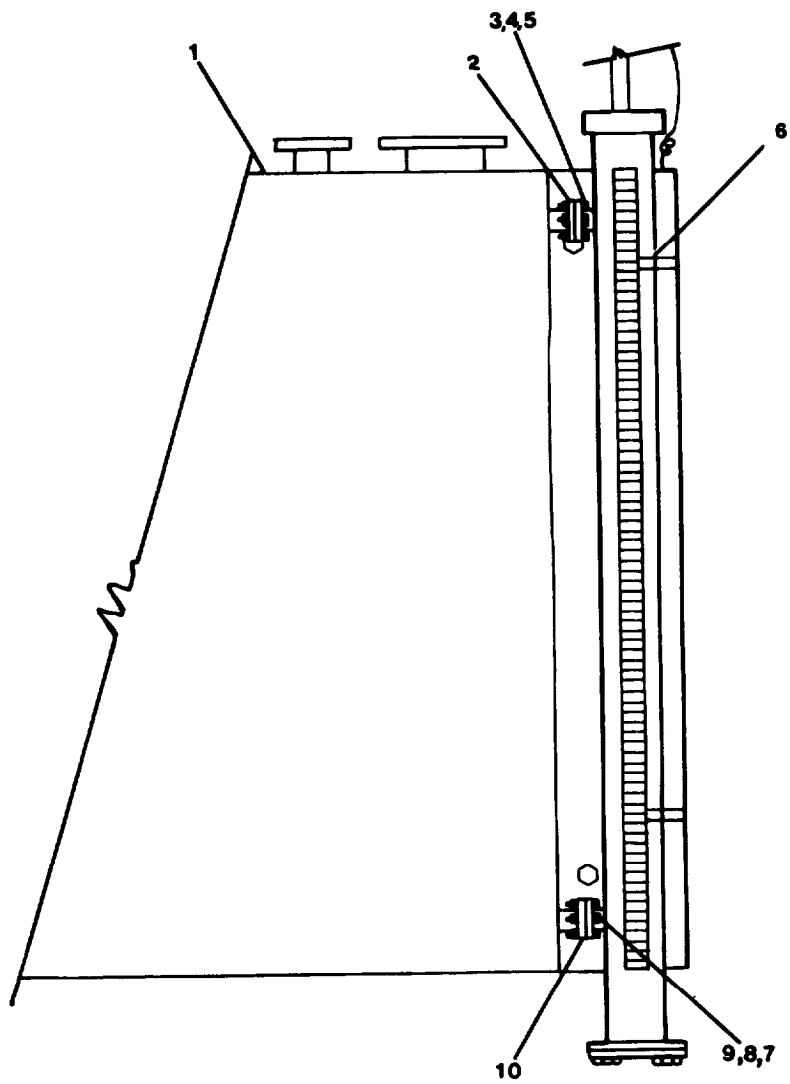
To prevent fire hazard or injury to personnel by slipping, any spilled fuel during repair procedures must be wiped up with rags immediately.

- a. Remove plain hexagon nut (3), lockwasher (4) and machine bolt (5).
- b. Remove plain hexagon nut (7), lockwasher (8) and machine bolt (9).
- c. Remove liquid quantity indicator (6) and gasket material (2, 10) from day tank (1).

**REPLACEMENT**

- a. Install gasket material (2, 10) and liquid quantity indicator (6) on day tank (1)
- b. Install machine bolt (9), lockwasher (8) and plain hexagon nut (7).
- c. Install machine bolt (5), lockwasher (4) and plain hexagon nut (3).
- d. Connect day tank liquid quantity indicator alarm, refer to TM 55-1905-223-10.
- e. Close drain valve and open fuel supply and fill valve to day tank, refer to TM 55-1905-223-10.

- f. Check for leaks and return system to normal operation, refer to TM 55-1905-223-10.



9 7 7 4

FIGURE 2-276. Repair Emergency Generator Day Tank.

2-380. Repair Bowthruster Engine Day Tank. (FIGURE 2-277)

---

This task covers: a. Removal, b. Replacement.

---

### INITIAL SETUP

#### Tools

Tool kit, general mechanic's,  
5180-00-699-5273

#### Materials/Parts

Rags, Item 14, Appendix C

#### Equipment Condition

Fuel supply and fill valves to day tank closed.  
Drain valve open to drain day tank, refer to TM 55-1905-223-10.  
Day tank liquid quantity indicator alarm disconnected.

---

### REMOVAL

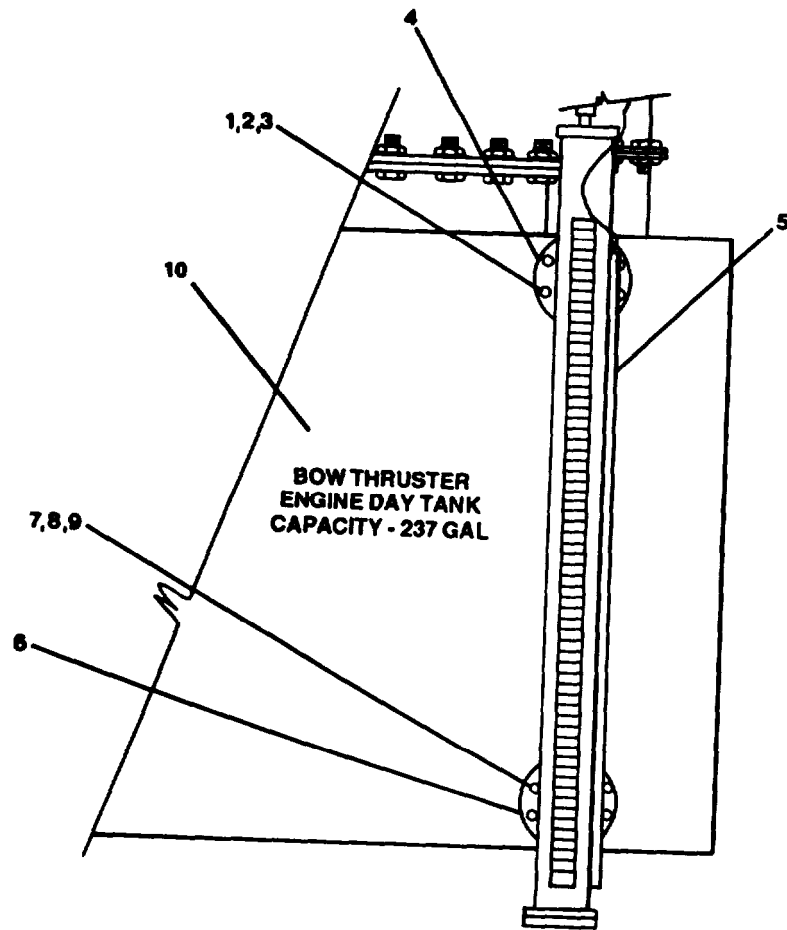
#### WARNING

To prevent fire hazard or injury to personnel by slipping, any spilled fuel during repair procedures must be wiped up with rags immediately.

- a. Remove plain hexagon nut (3), lockwasher (2) and machine bolt (1).
- b. Remove plain hexagon nut (7), lockwasher (8) and machine bolt (9).
- c. Remove liquid quantity indicator (5) and gasket material (4, 6) from day tank (10).

### REPLACEMENT

- a. Install gasket material (4, 6) and liquid quantity indicator (5) on day tank (10).
- b. Install machine bolt (9), lockwasher (8) and plain hexagon nut (7).
- c. Install machine bolt (1), lockwasher (2) and plain hexagon nut (3).
- d. Connect day tank liquid quantity indicator alarm.
- e. Close drain valve and open fuel supply and fill valve to day tank, refer to TM 55-1905-223-10.
- f. Check for leaks and return system to normal operation, refer to TM 55-1905-223-10.



9 773

FIGURE 2-277. Repair Bowthruster Engine Day Tank.

2-381. Repair Hydraulic Oil Storage Tank. (FIGURE 2-278)

---

This tank covers: a. Removal, b. Replacement.

---

### INITIAL SETUP

#### Tools

Tool kit, general mechanic's,  
5180-00-699-5273

#### Equipment Condition

Hydraulic oil storage tank liquid  
quantity indicator alarm wiring  
disconnected, refer to TM 55-1905-  
223-10.

#### Materials/Parts

Rags, Item 14, Appendix C

---

### Removal

#### WARNING

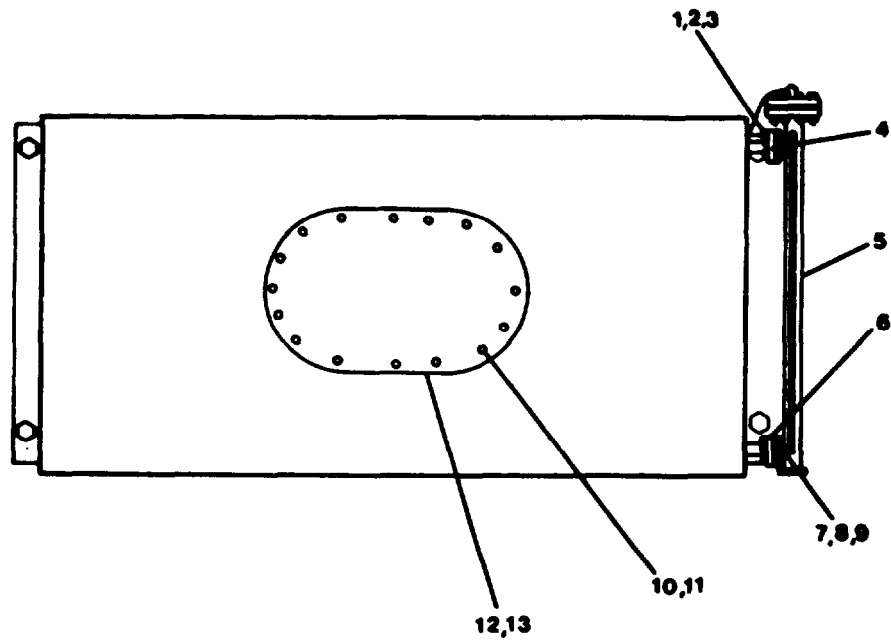
To prevent fire hazard or injury to  
personnel by slipping, any spilled hydraulic  
fluid during repair procedures must be wiped  
up with rags immediately

- a. Remove plain hexagon nut (3), lockwasher (2) and machine bolt (1).
- b. Remove plain hexagon nut (9), lockwasher (8) and machine bolt (7).
- c. Remove liquid quantity indicator (5) and gasket material (4, 6).
- d. Remove plain hexagon nut (11) and lockwasher (10).
- e. Remove steel plate (13) and gasket material (12).

### REPLACEMENT

- a. Install gasket material (12) and steel plate (18).
- b. Install lockwasher (10) and plain hexagon nut (11).
- c. Install gasket material (4, 6) and liquid quantity indicator (5).
- d. Install machine bolt (7), lockwasher (8) and plain hexagon nut (9).
- e. Install machine bolt (1), lockwasher (2) and plain hexagon nut (3).
- f. Connect hydraulic oil tank liquid quantity indicator alarm wiring.





9772

FIGURE 2-278 Repair Hydraulic Oil Storage Tank.

Section VI. PREPARATION FOR STORAGE OR SHIPMENT

2-382. Administrative storage of equipment issued to and used by Army activities will have preventive maintenance performed in accordance with the Preventive Maintenance Checks and Services (PMCS) charts before storing. When removing the equipment from administrative storage, the PMCS should be performed to ensure operational readiness. Removal of the pumps and motors for shipment or limited storage is covered in paragraphs 3-107 through 3-112. Use the following steps for repacking the pumps or motors for shipment or storage.

- a. Place all loose items in a plastic bag and secure the bag to the component removed.
- b. Place protective connector covers on all connectors.
- c. Securely crate the component to prevent damage during movement.
- d. Do not store with or near corrosive materials.

By Order of the Secretary of the Army:

**CARL E. VUONO**  
*General, United States Army*  
*Chief of Staff*

Official:

**WILLIAM J. MEEHAN, II**  
*Brigadier General, United States Army*  
*The Adjutant General*

**DISTRIBUTION:**

To be distributed in accordance with DA Form 12-25A, Unit, Intermediate Direct Support and Intermediate General Support Maintenance requirements for Landing Craft, Utility, LUC-1466, Type III

\* U. S. GOVERNMENT PRINTING OFFICE : 1993 0 - 342-421 (80599)



These are the instructions for sending an electronic 2028

The following format must be used if submitting an electronic 2028. The subject line must be exactly the same and all fields must be included; however only the following fields are mandatory: 1, 3, 4, 5, 6, 7, 8, 9, 10, 13, 15, 16, 17, and 27.

From: "Whomever" <whomever@avma27.army.mil>  
To: TACOM-TECH-PUBS@ria.army.mil

Subject: DA Form 2028  
1. From: Joe Smith  
2. Unit: home  
3. Address: 4300 Park  
4. City: Hometown  
5. St: MO  
6. Zip: 77777  
7. Date Sent: 19-OCT-93  
8. Pub no: 55-2840-249-23  
9. Pub Title: TM  
10. Publication Date: 04-JUL-85  
11. Change Number: 7  
12. Submitter Rank: MSG  
13. Submitter FName: Joe  
14. Submitter MName: T  
15. Submitter LName: Smith  
16. Submitter Phone: 123-123-1234  
17. Problem: 1  
18. Page: 1  
19. Paragraph: 3  
20. Line: 4  
21. NSN: 5  
22. Reference: 6  
23. Figure: 7  
24. Table: 8  
25. Item: 9  
26. Total: 123  
27. Text:

This is the text for the problem below line 27.



<b>RECOMMENDED CHANGES TO PUBLICATIONS AND BLANK FORMS</b> <small>For use of this form, see AR 310-1; the proponent agency is the US Army Adjutant General Center.</small>					<small>Use Part II (reverse) for Repair Parts and Special Tool Lists (RPSTL) and Supply Catalogs/Supply Manuals (SC/SM).</small>	<b>DATE:</b> Date form is filled out.
<b>TO:</b> <i>(Forward to proponent of publication or form) (include ZIP Code)</i> Mailing address found on title block page.					<b>FROM:</b> <i>(Activity and location) (include ZIP Code)</i> Your mailing address.	
<b>PART I- ALL PUBLICATIONS (EXCEPT RPSTL AND SC/SM) AND BLANK FORMS</b>						
<b>PUBLICATION/FORM NUMBER:</b> TM X-XXXX-XXX-XXX					<b>DATE:</b> Date of the TM.	<b>TITLE:</b> Title of TM.
<b>ITEM NO.</b>	<b>PAGE NO.</b>	<b>PARA-GRAPH</b>	<b>LINE NO.</b>	<b>FIGURE NO.</b>	<b>TABLE NO.</b>	<b>RECOMMENDED CHANGES AND REASON</b> <small>(Exact wording of recommended change must be given)</small>
	0019 00 1	3	1	1		Step No. 2 says to secure doors open with locking bar or hooks from where to what? The bars or hooks are not identified.
	0019 00 4	4	1	1		Step No. 19 states to remove locking bars, pins or hooks from where to what? The bars, pins or hooks are not identified. Where are they stored?
SAMPLE						
<small>* Reference to line numbers within the paragraph or subparagraph.</small>						
<b>TYPED NAME, GRADE OR TITLE</b> Doe, John, CPL			<b>TELEPHONE EXCHANGE/AUTOVON, PLUS EXTENSION</b> 755-1313		<b>SIGNATURE</b> <i>CPL John Doe</i>	

<b>TO:</b> (Forward to proponent of publication or form) (Include ZIP Code)	<b>FROM:</b> (Activity and location) (Include ZIP Code)	<b>DATE:</b>
---	---	--------------

**PART II - REPAIR PARTS AND SPECIAL TOOL LISTS AND SUPPLY CATALOGS/SUPPLY MANUALS**

<b>PUBLICATION/FORM NUMBER:</b> TM X-XXXX-XXX-XXX	<b>DATE:</b> Date of the TM.	<b>TITLE:</b> Title of TM.
--	---------------------------------	-------------------------------

PAGE NO.	COLM NO.	LINE NO.	FEDERAL STOCK NUMBER	REFERENCE NO.	FIGURE NO.	ITEM NO.	TOTAL NO. OF MAJOR ITEMS SUPPORTED	RECOMMENDED ACTION

**SAMPLE**

**PART III - REMARKS** (Any general remarks or recommendations, or suggestions for improvement of publications on blank forms. Additional blank sheets may be used if more space is needed.)

<sup>a</sup> Reference to line numbers within the paragraph or subparagraph.

TYPED NAME, GRADE OR TITLE Doe, John, CPL	TELEPHONE EXCHANGE/AUTOVON, PLUS EXTENSION 755-1313	SIGNATURE CPL John Doe
--	--	---------------------------



<b>RECOMMENDED CHANGES TO PUBLICATIONS AND BLANK FORMS</b>						Use Part II ( <i>reverse</i> ) for Repair Parts and Special Tool Lists (RPSTL) and Supply Catalogs/Supply Manuals (SC/SM).	<b>DATE</b>
For use of this form, see AR 25-30; the proponent agency is OAASA							
<b>TO</b> ( <i>Forward to proponent of publication or form</i> ) ( <i>Include ZIP Code</i> )						<b>FROM</b> ( <i>Activity and location</i> ) ( <i>Include ZIP Code</i> )	
<b>PART I - ALL PUBLICATIONS (EXCEPT RPSTL AND SC/SM) AND BLANK FORMS</b>							
<b>PUBLICATION/FORM NUMBER</b> TM 55-1905-223-24-18-1						<b>DATE</b> 17 JANUARY 1989	<b>TITLE</b> LANDING CRAFT, UTILITY (LCU) BASIC CRAFT (PART I) NSN 1905-01-154-1191
<b>ITEM</b>	<b>PAGE</b>	<b>PARA- GRAPH</b>	<b>LINE</b>	<b>FIGURE NO.</b>	<b>TABLE</b>	<b>RECOMMENDED CHANGES AND REASON</b>	
* Reference to line numbers within the paragraph or subparagraph.							
<b>TYPED NAME, GRADE OR TITLE</b>					<b>TELEPHONE EXCHANGE/AUTOVON, PLUS EXTENSION</b>		<b>SIGNATURE</b>

<b>TO</b> <i>(Forward direct to addressee listed in publication)</i>	<b>FROM</b> <i>(Activity and location) (Include ZIP Code)</i>	<b>DATE</b>
--	---	-------------

**PART II - REPAIR PARTS AND SPECIAL TOOL LISTS AND SUPPLY CATALOGS/SUPPLY MANUALS**

<b>PUBLICATION/FORM NUMBER</b> TM 55-1905-223-24-18-1	<b>DATE</b> 17 JANUARY 1989	<b>TITLE</b> LANDING CRAFT, UTILITY (LCU) BASIC CRAFT (PART I) NSN 1905-01-154-1191
--	--------------------------------	---

PAGE NO.	COLM NO.	LINE NO.	NATIONAL STOCK NUMBER	REFERENCE NO.	FIGURE NO.	ITEM NO.	TOTAL NO. OF MAJOR ITEMS SUPPORTED	RECOMMENDED ACTION

**PART III - REMARKS** *(Any general remarks, recommendations, or suggestions for improvement of publications and blank forms. Additional blank sheets may be used if more space is needed.)*

<b>TYPED NAME, GRADE OR TITLE</b>	<b>TELEPHONE EXCHANGE/AUTOVON, PLUS EXTENSION</b>	<b>SIGNATURE</b>
-----------------------------------	---	------------------

<b>RECOMMENDED CHANGES TO PUBLICATIONS AND BLANK FORMS</b>						Use Part II ( <i>reverse</i> ) for Repair Parts and Special Tool Lists (RPSTL) and Supply Catalogs/Supply Manuals (SC/SM).	DATE
For use of this form, see AR 25-30; the proponent agency is OAASA							
TO ( <i>Forward to proponent of publication or form</i> ) ( <i>Include ZIP Code</i> )						FROM ( <i>Activity and location</i> ) ( <i>Include ZIP Code</i> )	
<b>PART I - ALL PUBLICATIONS (EXCEPT RPSTL AND SC/SM) AND BLANK FORMS</b>							
PUBLICATION/FORM NUMBER TM 55-1905-223-24-18-1						DATE 17 JANUARY 1989	TITLE LANDING CRAFT, UTILITY (LCU) BASIC CRAFT (PART I) NSN 1905-01-154-1191
ITEM	PAGE	PARA-GRAPH	LINE	FIGURE NO.	TABLE	RECOMMENDED CHANGES AND REASON	
<i>* Reference to line numbers within the paragraph or subparagraph.</i>							
TYPED NAME, GRADE OR TITLE					TELEPHONE EXCHANGE/AUTOVON, PLUS EXTENSION		SIGNATURE

<b>TO</b> <i>(Forward direct to addressee listed in publication)</i>	<b>FROM</b> <i>(Activity and location) (Include ZIP Code)</i>	<b>DATE</b>
--	---	-------------

**PART II - REPAIR PARTS AND SPECIAL TOOL LISTS AND SUPPLY CATALOGS/SUPPLY MANUALS**

<b>PUBLICATION/FORM NUMBER</b> TM 55-1905-223-24-18-1	<b>DATE</b> 17 JANUARY 1989	<b>TITLE</b> LANDING CRAFT, UTILITY (LCU) BASIC CRAFT (PART I) NSN 1905-01-154-1191
--	--------------------------------	---

PAGE NO.	COLM NO.	LINE NO.	NATIONAL STOCK NUMBER	REFERENCE NO.	FIGURE NO.	ITEM NO.	TOTAL NO. OF MAJOR ITEMS SUPPORTED	RECOMMENDED ACTION

**PART III - REMARKS** *(Any general remarks, recommendations, or suggestions for improvement of publications and blank forms. Additional blank sheets may be used if more space is needed.)*

<b>TYPED NAME, GRADE OR TITLE</b>	<b>TELEPHONE EXCHANGE/AUTOVON, PLUS EXTENSION</b>	<b>SIGNATURE</b>
-----------------------------------	---	------------------

<b>RECOMMENDED CHANGES TO PUBLICATIONS AND BLANK FORMS</b>						Use Part II ( <i>reverse</i> ) for Repair Parts and Special Tool Lists (RPSTL) and Supply Catalogs/Supply Manuals (SC/SM).	<b>DATE</b>
For use of this form, see AR 25-30; the proponent agency is OAASA							
<b>TO</b> ( <i>Forward to proponent of publication or form</i> ) ( <i>Include ZIP Code</i> )						<b>FROM</b> ( <i>Activity and location</i> ) ( <i>Include ZIP Code</i> )	
<b>PART I - ALL PUBLICATIONS (EXCEPT RPSTL AND SC/SM) AND BLANK FORMS</b>							
<b>PUBLICATION/FORM NUMBER</b> TM 55-1905-223-24-18-1						<b>DATE</b> 17 JANUARY 1989	<b>TITLE</b> LANDING CRAFT, UTILITY (LCU) BASIC CRAFT (PART I) NSN 1905-01-154-1191
<b>ITEM</b>	<b>PAGE</b>	<b>PARA- GRAPH</b>	<b>LINE</b>	<b>FIGURE NO.</b>	<b>TABLE</b>	<b>RECOMMENDED CHANGES AND REASON</b>	
* Reference to line numbers within the paragraph or subparagraph.							
<b>TYPED NAME, GRADE OR TITLE</b>					<b>TELEPHONE EXCHANGE/AUTOVON, PLUS EXTENSION</b>		<b>SIGNATURE</b>

<b>TO</b> <i>(Forward direct to addressee listed in publication)</i>	<b>FROM</b> <i>(Activity and location) (Include ZIP Code)</i>	<b>DATE</b>
--	---	-------------

**PART II - REPAIR PARTS AND SPECIAL TOOL LISTS AND SUPPLY CATALOGS/SUPPLY MANUALS**

<b>PUBLICATION/FORM NUMBER</b> TM 55-1905-223-24-18-1	<b>DATE</b> 17 JANUARY 1989	<b>TITLE</b> LANDING CRAFT, UTILITY (LCU) BASIC CRAFT (PART I) NSN 1905-01-154-1191
--	--------------------------------	---

PAGE NO.	COLM NO.	LINE NO.	NATIONAL STOCK NUMBER	REFERENCE NO.	FIGURE NO.	ITEM NO.	TOTAL NO. OF MAJOR ITEMS SUPPORTED	RECOMMENDED ACTION

**PART III - REMARKS** *(Any general remarks, recommendations, or suggestions for improvement of publications and blank forms. Additional blank sheets may be used if more space is needed.)*

<b>TYPED NAME, GRADE OR TITLE</b>	<b>TELEPHONE EXCHANGE/AUTOVON, PLUS EXTENSION</b>	<b>SIGNATURE</b>
-----------------------------------	---	------------------

# The Metric System and Equivalents

## Linear Measure

1 centimeter = 10 millimeters = .39 inch  
 1 decimeter = 10 centimeters = 3.94 inches  
 1 meter = 10 decimeters = 39.37 inches  
 1 dekameter = 10 meters = 32.8 feet  
 1 hectometer = 10 dekameters = 328.08 feet  
 1 kilometer = 10 hectometers = 3,280.8 feet

## Liquid Measure

1 centiliter = 10 milliliters = .34 fl. ounce  
 1 deciliter = 10 centiliters = 3.38 fl. ounces  
 1 liter = 10 deciliters = 33.81 fl. ounces  
 1 dekaliter = 10 liters = 2.64 gallons  
 1 hectoliter = 10 dekaliters = 26.42 gallons  
 1 kiloliter = 10 hectoliters = 264.18 gallons

## Weights

1 centigram = 10 milligrams = .15 grain  
 1 decigram = 10 centigrams = 1.54 grains  
 1 gram = 10 decigram = .035 ounce  
 1 dekagram = 10 grams = .35 ounce  
 1 hectogram = 10 dekagrams = 3.52 ounces  
 1 kilogram = 10 hectograms = 2.2 pounds  
 1 quintal = 100 kilograms = 220.46 pounds  
 1 metric ton = 10 quintals = 1.1 short tons

## Square Measure

1 sq. centimeter = 100 sq. millimeters = .155 sq. inch  
 1 sq. decimeter = 100 sq. centimeters = 15.5 sq. inches  
 1 sq. meter (centare) = 100 sq. decimeters = 10.76 sq. feet  
 1 sq. dekameter (are) = 100 sq. meters = 1,076.4 sq. feet  
 1 sq. hectometer (hectare) = 100 sq. dekameters = 2.47 acres  
 1 sq. kilometer = 100 sq. hectometers = .386 sq. mile

## Cubic Measure

1 cu. centimeter = 1000 cu. millimeters = .06 cu. inch  
 1 cu. decimeter = 1000 cu. centimeters = 61.02 cu. inches  
 1 cu. meter = 1000 cu. decimeters = 35.31 cu. feet

## Approximate Conversion Factors

<i>To change</i>	<i>To</i>	<i>Multiply by</i>	<i>To change</i>	<i>To</i>	<i>Multiply by</i>
inches	centimeters	2.540	ounce-inches	newton-meters	.007062
feet	meters	.305	centimeters	inches	.394
yards	meters	.914	meters	feet	3.280
miles	kilometers	1.609	meters	yards	1.094
square inches	square centimeters	6.451	kilometers	miles	.621
square feet	square meters	.983	square centimeters	square inches	.155
square yards	square meters	.836	square meters	square feet	10.764
square miles	square kilometers	2.590	square meters	square yards	1.196
acres	square hectometers	.405	square kilometers	square miles	.386
cubic feet	cubic meters	.028	square hectometers	acres	2.471
cubic yards	cubic meters	.765	cubic meters	cubic feet	35.315
fluid ounces	milliliters	29.573	cubic meters	cubic yards	1.308
pints	liters	.473	milliliters	fluid ounces	.034
quarts	liters	.946	liters	pints	2.113
gallons	liters	3.785	liters	quarts	1.057
ounces	grams	28.349	liters	gallons	.264
pounds	kilograms	.454	grams	ounces	.035
short tons	metric tons	.907	kilograms	pounds	2.205
pound-foot	newton-meters	1.356	metric tons	short tons	1.102
pound-inches	newton meters	.11296			

## Temperature (Exact)

°F	Fahrenheit temperature	5/9 (after subtracting 32)	Celsius temperature	°C
----	------------------------	----------------------------	---------------------	----

**PIN: 066257-000**